

① **18-5001D** Display Package



18-5001
TUNE-UP KIT
Replaces: 172525

—CONTAINS—

Part #	O.E. #	Description
18-5157	580290	Contact Set
18-5200	580256	Condenser

18-5250
TUNE-UP KIT
Replaces: 172527

—CONTAINS—

Part #	O.E. #	Description
18-5311	380538	Contact Set
18-5345	380537	Condenser
18-5418	384735	Rotor

Delco 4 & 6 cyl.

18-5251
TUNE-UP KIT
Replaces: 173619

—CONTAINS—

Part #	O.E. #	Description
18-5314	382135	Contact Set
18-5338	382136	Condenser
18-5404-1	982211	Rotor

18-5376 cap

18-5256
TUNE-UP KIT
Replaces: 172531

—CONTAINS—

Part #	O.E. #	Description
18-5314	382135	Contact Set
18-5338	382136	Condenser
18-5411	982342	Rotor

Mallory 8 cyl. Flat Cap

① **18-5258D** Display Package

18-5258
TUNE-UP KIT
Replaces: 173690, 987925

—CONTAINS—



Part #	O.E. #	Description
18-5303	980893	Contact Set
18-5347	980894	Condenser
18-5407	980892	Rotor

Prestolite 8 cyl.

18-5260
TUNE-UP KIT
Replaces: 173829, 987926

—CONTAINS—

Part #	O.E. #	Description
18-5303	980893	Contact Set
18-5347	980894	Condenser
18-5403	982880	Rotor

18-5266
TUNE-UP KIT
Fits: Flame Thrower Distributors 18-5481, 18-5482, 18-5483, 18-5477, 18-5478 and 18-5479

18-5268
TUNE-UP KIT

—CONTAINS—

Part #	O.E. #	Description
18-5311	380538	Contact Set
18-5345	380537	Condenser
18-5418	384735	Rotor
18-5385	380541	Distributor Cap

Delco In-Line 4 - Single Point

18-5269
TUNE-UP KIT

—CONTAINS—

Part #	O.E. #	Description
18-5311	380538	Contact Set
18-5345	380537	Condenser
18-5418	384735	Rotor
18-5386	980152	Distributor Cap

Delco In-Line 6 - Single Point

18-5252
TUNE-UP KIT

—CONTAINS—

Part #	Description
18-5310	Contact Set
18-5344	Condenser
-	Rotor

Delco 8 cyl.

18-5270
TUNE-UP KIT

—CONTAINS—

Part #	O.E. #	Description
18-5310	380543	Contact Set
18-5344	382125	Condenser
-	381711	Rotor
18-5384	383587	Distributor Cap

Delco V-8 - Single Point

18-5271
TUNE-UP KIT

—CONTAINS—

Part #	O.E. #	Description
18-5314	382135	Contact Set
18-5338	382136	Condenser
18-5404-1	982211	Rotor
18-5376	982209	Distributor Cap

Mallory V-8 - Single Point - Top Terminal

18-5272
TUNE-UP KIT

—CONTAINS—

Part #	O.E. #	Description
18-5314	382135	Contact Set
18-5338	382136	Condenser
18-5411	982342	Rotor
18-5375	382133	Distributor Cap

Mallory Flat V-8 - Single Point - Side Terminal - Flat Cap

18-5275
TUNE-UP KIT







—CONTAINS—

Part #	O.E. #	Description
18-5303	980893, 987136,	Contact Set
-	987894	-
18-5347	980894, 987895	Condenser
18-5403	982880	Rotor
18-5352	984401	Distributor Cap

Prestolite V-8 - Single Point - Screw Cap

APPLICATION BEGINS ON PAGE 870

① Items ending in "D" are Display Packaged - Regular number is Non-Display

 <p>18-5276 TUNE-UP KIT —CONTAINS— Part # O.E. # Description 18-5303 980893, 987136, Contact Set 987894 18-5347 980894, 987895 Condenser 18-5403 982880 Rotor 18-5353 984398 Distributor Cap Prestolite V-6 - Single Point - Screw Cap</p>	 <p>18-5277 TUNE-UP KIT —CONTAINS— Par t# O.E. # Description 18-5303 980893, 987136, 987894 Contact Set 18-5347 980894, 987895 Condenser 18-5407 980892 Rotor 18-5369 982336 Distributor Cap Prestolite V-8 - Single Point - Clip Cap</p>	 <p>18-5278 TUNE-UP KIT For: Delco EST V-6</p>	 <p>18-5279 TUNE-UP KIT For: Prestolite Electronic V-8 —CONTAINS— Part # Description O.E.# Qty. 18-5352 Distributor Cap 392-9766 1 18-5403 Rotor 392-9089 1</p>	
 <p>18-5280 TUNE-UP KIT For: Delco EST In-Line 4 —CONTAINS— Part # Description O.E.# Qty. 18-5361 Distributor Cap 986643 1 18-5406 Rotor, Delco 986651 1</p>	 <p>18-5281 TUNE-UP KIT For: Delco EST • V-8</p>	 <p>18-5283 TUNE-UP KIT For: Mallory Single Point In-Line 4 —CONTAINS— Part # Description 18-5397 Distributor Cap 18-5404-1 Rotor 18-5314 Contact Set 18-5338 Condenser</p>	 <p>18-5157 CONTACT SET Replaces: 580290</p>	
 <p>18-5303 CONTACT SET Replaces: 980893, 987136, 987894</p>	 <p>18-5310 CONTACT SET Replaces: 380543</p>	 <p>18-5311 CONTACT SET Replaces: 380538</p>	 <p>18-5314 CONTACT SET Replaces: 382135</p>	 <p>18-5200 CONDENSER Replaces: 580256</p>
 <p>18-5338 CONDENSER Replaces: 382136</p>	 <p>18-5344 CONDENSER Replaces: 382125</p>	 <p>18-5345 CONDENSER Replaces: 380537</p>	 <p>18-5347 CONDENSER Replaces: 980894, 987895</p>	 <p>18-5403 ROTOR Replaces: 982880</p>
 <p>18-5404-1 ROTOR Replaces: 982211</p>	 <p>18-5405 ROTOR Replaces: 3854549 V-8 Fits new GM style "Module in Cap"</p>	 <p>18-5406 ROTOR Replaces: 986651 Use with 18-5361 Distributor Cap</p>	 <p>18-5407 ROTOR Replaces: 980892</p>	 <p>18-5408 ROTOR Replaces: 3854311 V-6 Fits new GM style "Module in Cap"</p>

APPLICATION BEGINS ON PAGE 870



18-5411
ROTOR
 Replaces: 982342



18-5413
ROTOR
 Replaces: 987986



18-5418
ROTOR
 Replaces: 384735



18-5419
ROTOR
 Replaces: 380542



18-5301
TUNE-UP KIT
 Fits: Male cap V-8 flamethrower distributors



18-5302
TUNE-UP KIT
 Fits: Male cap v-8 flamethrower distributors



18-5473
DISTRIBUTOR CAP
 Black Distributor Cap with Male Terminals for Flamethrower Distributors



18-5474
DISTRIBUTOR CAP
 Red Distributor Cap with Male Terminals for Flamethrower Distributors



18-5248
DISTRIBUTOR CAP
 Replaces: 3854217
 Fits: OMC 5.0L(1994-96), 5.8L(1994-96)



18-5352
DISTRIBUTOR CAP
 Replaces: 984401
 Prestolite



18-5353
DISTRIBUTOR CAP
 Replaces: 984398
 Prestolite



18-5354
DISTRIBUTOR CAP
 Replaces: 3854548
 V-8
 Fits new GM style "module in cap"



18-5361
DISTRIBUTOR CAP
 Replaces: 986643



18-5362
DISTRIBUTOR CAP
 Replaces: 3854331
 V-6
 Fits new GM style "Module in Cap"



18-5369
DISTRIBUTOR CAP
 Replaces: 982336
 w/Gasket **18-5399**



18-5375
DISTRIBUTOR CAP
 Replaces: 382133



18-5376
DISTRIBUTOR CAP
 Replaces: 982209
 Mallory



18-5384
DISTRIBUTOR CAP
 Replaces: 383587



18-5385
DISTRIBUTOR CAP
 Replaces: 380541



18-5386
DISTRIBUTOR CAP
 Replaces: 980152



18-5397
DISTRIBUTOR CAP
 Replaces: 985218
 Mallory 9-29418
 Fits: Ford 2.3L w/Mallory Distributor (87-90)



18-5107-1
IGNITION MODULE
 Replaces: 3854003
 4/6/8 cyl



18-5108
SENSOR (PICK-UP COIL)
 Replaces: 3854001, 986642
 4, V-6 and V-8 cyl



18-5493
IGNITION PICKUP COIL ASSEMBLY
 Replacement pick-up coil for Accel Electronic Distributors



18-5464
IGNITION MODULE
 Fits: Sierra 18-5481, 18-5482 and 18-5483 Billet HI-PERFORMANCE ELECTRONIC DISTRIBUTORS (except HEI/EST)

 <p>18-26810 GM HEI 4 TERMINAL PIGTAIL Fits: GM HEI Distributors w/4 terminals</p>	 <p>18-26811 GM HEI 2 TERMINAL PIGTAIL Fits: GM HEI Distributors w/2 terminals</p>	 <p>18-26812 HEI COIL GRAY CONNECTOR</p>	 <p>18-26813 HEI COIL BLACK CONNECTOR</p>	 <p>18-29322 CAP & ROTOR KIT Fits: Ford HEI Distributors</p>
---	---	---	---	---

FEATURES

- ★ Oil filled for better cooling and long life
- ★ Low resistance and improved turn ratios produces the higher voltage needed to run larger spark plug gaps for added power and better fuel economy
- ★ More windings maximize energy and reliability over the full RPM range
- ★ Fits existing brackets for easy installation



 <p>18-5466 HI-PERFORMANCE IGNITION COIL 1.5 ohm (oil filled), black - 8 cylinder: Flame-Thrower 40,000 volt coil. ★ Designed for use with the original Ignitor Electronic Conversion Kits ★ Can be used with other inductive ignition systems</p>	 <p>18-5469 HI-PERFORMANCE IGNITION COIL 3.0 ohm (oil filled), black - 4 & 6 cylinder: Flame-Thrower 40,000 volt coil. ★ Designed for use with the original Ignitor Electronic Conversion Kits ★ Can be used with other inductive ignition systems</p>	 <p>18-5472 HI-PERFORMANCE IGNITION COIL 0.6 ohm (oil filled), black - 4, 6, & 8 cylinder: Flame-Thrower 45,000 volt coil. ★ Super low 0.6 ohm resistance coil designed for use with the Ignitor II Hi Performance Electronic Conversion Kits ★ Compatible with capacitive discharge systems</p>
---	--	---

Part #	Description	Recommended Coil	Resistance Ohms	Part #	Description	Recommended Coil	Resistance Ohms
18-5293-1	Electronic Conversion Kit	18-5469	3.0	18-5288	Hi Performance Electronic Conversion Kit	18-5472	0.6
18-5294	Electronic Conversion Kit	18-5469	3.0	18-5289	Hi Performance Electronic Conversion Kit	18-5472	0.6
18-5295	Electronic Conversion Kit	18-5469	3.0	18-5290	Hi Performance Electronic Conversion Kit	18-5472	0.6
18-5296-2	Electronic Conversion Kit	18-5466	1.5	18-5481	Flame-Thrower Distributor	18-5472	0.6
18-5298	Electronic Conversion Kit	18-5466	1.5	18-5482	Flame-Thrower Distributor	18-5472	0.6
18-5299	Electronic Conversion Kit	18-5466	1.5	18-5483	Flame-Thrower Distributor	18-5472	0.6
18-5286	Hi Performance Electronic Conversion Kit	18-5472	0.6				

 <p>18-5433 IGNITION COIL Replaces: 915735 Uses External Resistor For: 3.0L (1991 & up), 5.7 EFI (1996 & up) and 7.4L EFI (1995 & up)</p>	 <p>18-5437 IGNITION COIL Replaces: 383444, 378231 Metal Encased - 12 Volt Uses External Resistor (For All Applications) For: 1990 & prior stern drives with breaker point ignition</p>	 <p>18-5443 IGNITION COIL Replaces: 3854002 4 cyl./V-8 For: 3.0L (1991 & up), 5.7 EFI (1996 & up) & 7.4 EFI (1995 & up)</p>
--	---	--

 <p>18-5888 SHIFT ASSIST MODULE & HARNESS Replaces: 987738 For: V-8 Sterndrives Fits: 5.0, 5.7 GM (1986-90) 7.5 460 Ford (1987-91)</p>	 <p>18-5889 SHIFT ASSIST MODULE & HARNESS Replaces: 987739 For: V-8 Sterndrives Fits: 5.0, 5.8 Ford (1986-90)</p>	 <p>18-5890 SHIFT ASSIST MODULE & HARNESS Replaces: 987740, 985902 Fits: 2.3, 3.0, 4.3 (1986-90) & 2.5 (1986)</p>
---	---	--

APPLICATION BEGINS ON PAGE 870

Ignitor® II

ELECTRONIC IGNITION

FEATURES

- ★ Senses current levels in the coil and adjusts the dwell to maintain peak energy throughout the entire RPM range.
- ★ Develops, on average, 4 times more available energy between 3000 and 5000 RPM's and twice as much plug voltage as point-type systems.
- ★ Ignition energy is sustained and coil life is increased when peak current level is reached just prior to spark.
- ★ More stable timing.
- ★ Use with 18-5472 "Flame Thrower II" Coil for optimum performance



18-5285
HI-PERFORMANCE
ELECTRONIC CONVERSION KIT
 Fits: 4 Cylinder Delco Distributors



18-5286
HI-PERFORMANCE
ELECTRONIC CONVERSION KIT
 Fits: 6 Cylinder Delco Distributors



18-5287-1
HI-PERFORMANCE
ELECTRONIC CONVERSION KIT
 Fits: Fits: 6 Cylinder Prestolite Distributors



18-5288
HI-PERFORMANCE
ELECTRONIC CONVERSION KIT
 Fits: Most Prestolite V-8 Distributors with snap down cap



18-5289
HI-PERFORMANCE
ELECTRONIC CONVERSION KIT
 Fits: Most Prestolite V-8 Distributors with screw down cap



18-5290
HI-PERFORMANCE
ELECTRONIC CONVERSION KIT
 Fits: Most Mallory YL or YD 8 cylinder Distributors with clockwise and counter clockwise rotation

IGNITOR®

ELECTRONIC IGNITION

FEATURES

- ★ Replaces points & condensers for true solid state ignition.
- ★ Uses standard coil, cap and rotor.
- ★ Easy to install, one-piece, 2-wire hook-up.
- ★ Accurate to within 1/4° timing accuracy 0 to 6000 RPM range.

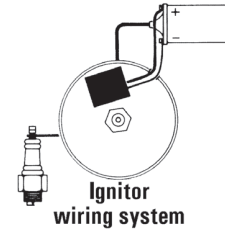
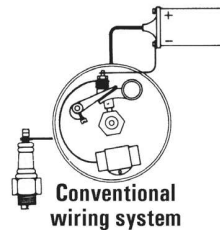

Not compatible with shift assist modules



18-5293-1
ELECTRONIC CONVERSION KIT
 For: All Chevrolet V-6 Prestolite with screw down caps



18-5294
ELECTRONIC CONVERSION KIT
 Fits: 6 Cyl. Delco distributors



18-5295
ELECTRONIC CONVERSION KIT
 Fits: Most 4 Cyl. Prestolite distributors (except IBM 7026)
 For: Onan, Universal, Waukesha, Wisconsin

Not compatible with shift assist modules

APPLICATION BEGINS ON PAGE 870

① 18-5296-2 Display Package



**18-5296-2
ELECTRONIC
CONVERSION KIT**
Fits: Most Mallory YL & YD 8 cyl.
Distributors with clockwise and counter
clockwise rotation

① 18-5297D Display Package



**18-5297
ELECTRONIC
CONVERSION KIT**
For 4 Cyl. Delco Distributors

① 18-5298



**18-5298
ELECTRONIC
CONVERSION KIT**
(with snap down cap)
For: Most Prestolite V-8 Distributors

① 18-5299D Display Package





**18-5299
ELECTRONIC
CONVERSION KIT**
(with screw down cap)
For: Most Prestolite V-8 Distributors
Use with 18-5403 style rotor

Not compatible with shift assist modules

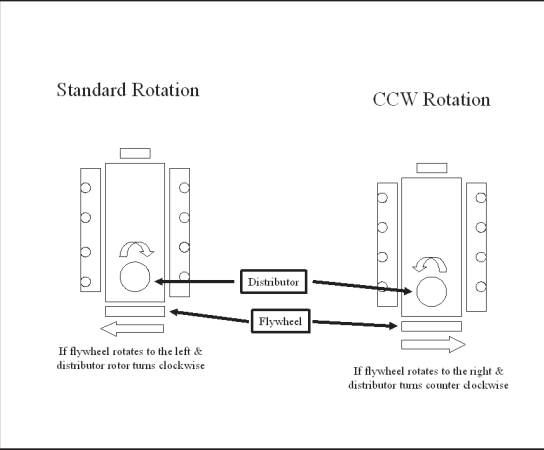

FEATURES

- ★ *Distributors feature the Ignitor II ignition module with adaptive dwell control adjusts the spark timing over the entire RPM range to maximize performance*
- ★ *Upper roller bearing and oil impregnated bronze sintered bottom bushing are installed and aligned bored for accuracy for maximum durability*
- ★ *Machined heat treated gear with tight tolerances insures durability and consistent timing to maximize horsepower and performance. Complete with high dielectric strength cap and rotor for years of performance*

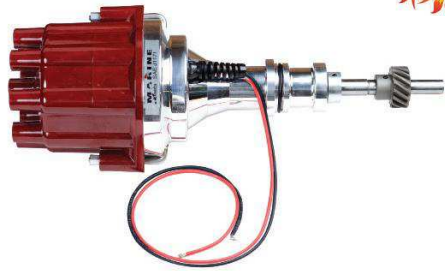
**18-5477
ELECTRONIC DISTRIBUTOR**
Fits: Ford 302 V-8 engines
Replacement Cap/Rotor Kit 18-5266



**18-5480
COMPLETE
IGNITION CONVERSION KIT**
Fits: GM SB & BB with Standard Deck Height
—CONTAINS—

<p>Part # 18-5472 18-8803-2 18-5483</p>	<p>Description Coil Wire Set Distributor</p>
---	--



**18-5481
HI-PERFORMANCE
ELECTRONIC
DISTRIBUTOR**
Fits: Ford V-8 351 Windsor
Replacement cap/rotor kit: 18-5266





**18-5482
HI-PERFORMANCE
ELECTRONIC
DISTRIBUTOR**
Fits: Ford V-8 351 Cleveland, 351M, 400,
429 and 460 engines
Replacement cap/rotor kit: 18-5266



**18-5483
HI-PERFORMANCE
ELECTRONIC
DISTRIBUTOR**
Fits: Chevrolet Marine Small and Big Block
engines (Standard Deck Height)
Replacement cap/rotor kit: 18-5266

APPLICATION BEGINS ON PAGE 870

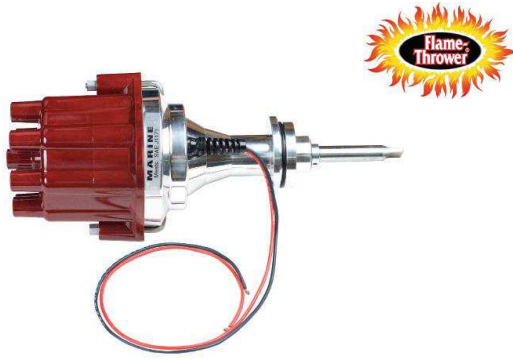
① Items ending in "D" are Display Packaged - Regular number is Non-Display



18-5478
ELECTRONIC DISTRIBUTOR
 Chrysler LA series V-8 engines
 Replacement Cap/Rotor Kit [18-5266](#)



18-5479
ELECTRONIC DISTRIBUTOR
 GM V-8 engines-reverse rotation
 Replacement Cap/Rotor Kit [18-5266](#)



18-5476
DISTRIBUTOR
 Fits: GM V-6 engines with Delco EST ignition HEI
 Tune-Up Kit [18-5278](#)



18-5486-2
ELECTRONIC DISTRIBUTOR
 Replaces: Mallory YLM673AV
 Conventional Rotation
 For: Chevrolet L4, 153 & 181 CID
 —CONTAINS—

Part #	Description
18-5397	Distributor Cap
18-5488	Module
18-5404-1	Rotor



18-5487-2
ELECTRONIC DISTRIBUTOR
 Replaces: 9-26309, Mallory YLM676AV
 Conventional Rotation
 For: GM L6, 194, 230, 250, 292 CID
 —CONTAINS—

Part #	Description
18-5488	Module
18-5404-1	Rotor



18-5489-2
ELECTRONIC DISTRIBUTOR
 Replaces: Mallory YLM554CV
 Conventional Rotation
 For: Ford V8 351W CID
 —CONTAINS—

Part #	Description
18-5376	Distributor Cap
18-5488	Module
18-5404-1	Rotor



18-5494-2
ELECTRONIC DISTRIBUTOR
 Replaces: Mallory YLM624AV
 Conventional Rotation
 For: Chevrolet all V8 includes 482, 502, 540 CID
 (Except 348,409 & Tall Deck Big Block)
 —CONTAINS—

Part #	Description
18-5376	Distributor Cap
18-5488	Module
18-5404-1	Rotor



18-5495-2
ELECTRONIC DISTRIBUTOR
 Replaces: Mallory YLM512CV
 Conventional Rotation
 For: Ford V8 302 CID
 —CONTAINS—

Part #	Description
18-5376	Distributor Cap
18-5488	Module
18-5404-1	Rotor



18-5496-2
ELECTRONIC DISTRIBUTOR
 Replaces: Mallory YLM567CV
 Conventional Rotation
 For: Ford V8 351C — 460 CID
 —CONTAINS—

Part #	Description
18-5376	Distributor Cap
18-5488	Module
18-5404-1	Rotor

18-5484-1
ELECTRONIC DISTRIBUTOR
 Replaces: 3857400, 3850399
 Late HEI
Conventional Rotation
 V8 262-454 & 502 except 348/409 and tall block engines
 • Designed as a plug-in replacement for GM-style fuel injection system distributors

—CONTAINS—	
Description	Part #
Distributor Cap	18-5354
Rotor	18-5405

Tune-Up Kit **18-5281**



18-5498-2
ELECTRONIC DISTRIBUTOR
 Replaces: 9-26307; Mallory YLM624BV
 For GM V8, 482, 502, 540 CID (Except 348, 409 & Tall Deck Big Block) (Reverse Rotation)



18-5339-1
DISTRIBUTOR
 Replaces: 9-26103; Mallory YL566AV
 For GM V8 327



18-5475
DISTRIBUTOR
 Fits: 4 Cyl. GM Engines with Delco EST Ignition HEI
 Tune-Up Kit **18-5280**



18-5309-1
DISTRIBUTOR
 Contact Controlled
 Replaces: 980902; Mallory YL512CV
 For most Ford 302 CID V-8 Eng.
 Tune-Up Kit **18-5251**



18-5316-1
DISTRIBUTOR
 Replaces: Mallory YL624BV
 Fits Most GM V8 (Reverse Rotation)



18-5312-1
DISTRIBUTOR
 Contact Controlled
 Replaces: 981080; Mallory YL554CV
 For most Ford 351 CID V-8 Eng.
 Tune-Up Kit **18-5251**



18-5313-1
DISTRIBUTOR
 Contact Controlled
 Replaces: 985560; Mallory YL624MW
 For most GM V-8 Engs. (small & large blocks)
 Tune-Up Kit **18-5251**



18-5315-1
DISTRIBUTOR
 Contact Controlled
 Replaces: Mallory YL673AV
 For most GM 4 Cyl. Engines (120 & 140 HP)
 Tune-Up Kit **18-5251**



18-26110-1
DISTRIBUTOR
 Replaces: 9-26110; Mallory YL579AV
 For Chrysler V8, 273, 318 (1967 & Up), 340 and 360 "LA" Engines



18-26104-1
DISTRIBUTOR
 Replaces: 9-26104; Mallory YL567EV
 For Ford V8 351C



18-26112-1
DISTRIBUTOR
 Replaces: 9-26112; Mallory YL676AV
 Fits GM L6, 194, 230, 250, 292 CID (Conventional Rotation)



APPLICATION BEGINS ON PAGE 870

OMC IGNITION APPLICATION CHART

Model	Year Start	Year Stop	Cylinder	Distributor	Contact Set	Condenser	Dist. Cap	Rotor	Tune-Up Kit w/o Cap	Tune-Up Kit w/ Cap	Plug Wire Set
2.3L	1987	1990	4	Mallory	18-5314	18-5338	18-5397	18-5404-1	-	18-5283	18-8807-1
2.3L	1990	1990	4	Prestolite	18-5303	18-5347	-	18-5403	18-5260	-	18-8807-1
2.5L	1981	1986	4	Delco	18-5311	18-5345	18-5385	18-5418	18-5250	18-5268	18-8800-1
3.0L	1982	1990	4	Delco	18-5311	18-5345	18-5385	18-5418	18-5250	18-5268	18-8800-1
3.0L	1990	1998	4	Delco EST	N/A	N/A	18-5361	18-5406	-	18-5280	18-8833-1
3.8L	1981	1985	6	Prestolite	18-5303	18-5347	18-5353	18-5403	18-5262	18-5276	18-8801-1
4.3L	1985	1990	6	Prestolite ②	18-5303	18-5347	18-5353	18-5403	18-5262	18-5276	18-8801-1
4.3L	1991	1993	6	Prestolite	N/A	N/A	18-5353	18-5403	-	-	18-8801-1
4.3L	1994	1998	6	Delco EST	N/A	N/A	18-53626	18-5408	-	18-5278	18-8835-1
5.0L (GM)	1979	1982	8	Prestolite ①	18-5303	18-5347	18-5369	18-5407	18-5258	18-5277	18-8802-1
5.0L (GM)	1981	1988	8	Mallory	18-5314	18-5338	18-5376	18-5404-1	18-5251	18-5271	18-8802-1
5.0L (GM)	1983	1988	8	Prestolite ②	18-5303	18-5347	18-5352	18-5403	18-5262	18-5275	18-8802-1
5.0L (Ford)	1989	1990	8	Prestolite ②	18-5303	18-5347	18-5352	18-5403	18-5262	18-5275	18-8806-1
5.0L (Ford)	1991	1996	8	Prestolite	N/A	N/A	18-5352	18-5403	-	18-5279	18-8806-1
5.0L (Ford)	1993	1996	8	Ford HEI	N/A	N/A	18-5248	18-5413	-	18-29322	18-8820-1
5.0L (GM)	1998	1998	8	Prestolite	N/A	N/A	18-5352	18-5403	-	18-5279	18-8801-1
5.0L (GM)	1998	1998	8	Delco EST	N/A	N/A	18-5354	18-5405	-	18-5281	18-8822-1
5.7L	1982	1990	8	Mallory	18-5314	18-5338	18-5376	18-5404-1	18-5251	18-5271	18-8802-1
5.7L	1982	1990	8	Prestolite ②	18-5303	18-5347	18-5352	18-5403	18-5262	18-5275	18-8802-1
5.7L	1991	1998	8	Prestolite ②	N/A	N/A	18-5352	18-5403	-	18-5279	18-8802-1
5.7L	1996	1998	8	Delco EST	N/A	N/A	18-5354	18-5405	-	18-5281	18-8822-1
5.8L	1989	1990	8	Prestolite ②	18-5303	18-5347	18-5352	18-5403	18-5262	18-5275	18-8842-1
5.8L	1991	1996	8	Prestolite ②	N/A	N/A	18-5352	18-5403	-	18-5279	18-8842-1
5.8L	1993	1996	8	Ford HEI	N/A	N/A	18-5248	18-5413	-	18-29322	18-8820-1
7.4L	1988	1988	8	Mallory	18-5314	18-5338	18-5376	18-5404-1	18-5251	18-5271	18-8802-1
7.4L	1988	1988	8	Prestolite ②	18-5303	18-5347	18-5352	18-5403	18-5262	18-5275	18-8802-1
7.4L	1990	1991	8	Distributor-less	-	-	-	-	-	-	18-8843-1
7.4L	1995	1998	8	Delco EST	N/A	N/A	18-5354	18-5405	-	18-5281	18-8832-1
7.5L	1987	1987	8	Prestolite ①	18-5303	18-5347	18-5369	18-5407	18-5258	18-5277	18-8803-2
7.5L	1987	1989	8	Prestolite ①	18-5303	18-5347	18-5352	18-5407	18-5258	18-5277	18-8803-2
8.2L	1984	1985	8	Mallory	18-5314	18-5338	18-5376	18-5404-1	18-5251	18-5271	18-8802-1
8.2L	1984	1985	8	Prestolite ②	18-5303	18-5347	18-5352	18-5403	18-5262	18-5275	18-8802-1
8.2L	1998	1998	8	Delco EST	N/A	N/A	18-5354	18-5405	-	18-5281	18-8832-1
80	1962	1968	4	ALL	18-5157	18-5200	-	-	18-5001	-	18-8800-1
90	1962	1968	4	ALL	18-5157	18-5200	-	-	18-5001	-	18-8800-1
100	1972	1973	4	Delco	18-5311	18-5345	18-5385	18-5418	18-5250	18-5268	18-8800-1
110	1964	1964	4	Delco	18-5311	18-5345	18-5385	18-5418	18-5250	18-5268	18-8800-1
120	1965	1981	4	Delco	18-5311	18-5345	18-5385	18-5418	18-5250	18-5268	18-8800-1
140	1973	1981	4	Delco	18-5311	18-5345	18-5385	18-5418	18-5250	18-5268	18-8800-1
150	1964	1966	6	Delco	18-5310	18-5345	-	18-5419	-	-	-
155	1967	1972	6	Delco	18-5310	18-5344	-	18-5419	-	-	-
165	1972	1976	6	Delco	18-5311	18-5345	18-5386	18-5418	18-5250	18-5269	-
170	1974	1974	8	Prestolite ①	18-5303	18-5347	18-5369	18-5407	18-5258	18-5277	18-8802-1
175	1975	1977	8	Prestolite ①	18-5303	18-5347	18-5369	18-5407	18-5258	18-5277	18-8802-1
185	1967	1968	8	Mallory	18-5314	18-5338	18-5375	18-5411	18-5256	18-5272	18-8802-1
185	1978	1980	8	Mallory	18-5314	18-5338	18-5376	18-5404-1	18-5251	18-5271	18-8802-1
185	1978	1980	8	Prestolite ①	18-5303	18-5347	18-5369	18-5407	18-5258	18-5277	18-8802-1
190	1974	1977	8	Prestolite ①	18-5303	18-5347	18-5369	18-5407	18-5258	18-5277	18-8802-1
200	1966	1966	8	Delco	18-5310	18-5345	18-5384	18-5300	-	18-5270	-
200	1967	1968	8	Delco	18-5310	18-5344	18-5384	18-5300	18-5252	18-5270	-









① Clip down distributor cap ② Screw down distributor cap

APPLICATION CONTINUED ON NEXT PAGE

OMC IGNITION APPLICATION CHART

Model	Year Start	Year Stop	Cylinder	Distributor	Contact Set	Condenser	Dist. Cap	Rotor	Tune-Up Kit w/o Cap	Tune-Up Kit w/ Cap	Plug Wire Set
200	1979	1988	8	Mallory	18-5314	18-5338	18-5376	18-5404-1	18-5251	18-5271	18-8802-1
200	1979	1981	8	Prestolite ①	18-5303	18-5347	18-5369	18-5407	18-5258	18-5277	18-8802-1
210	1968	1970	8	Mallory	18-5314	18-5338	18-5375	18-5411	18-5256	18-5272	18-8802-1
215	1971	1971	8	Mallory	18-5314	18-5338	18-5375	18-5411	18-5256	18-5272	18-8802-1
225	1972	1976	8	Mallory	18-5314	18-5338	18-5375	18-5411	18-5256	18-5272	18-8802-1
225	1978	1978	8	Mallory	18-5314	18-5338	18-5376	18-5404-1	-	18-5271	18-8802-1
230	1979	1981	8	Mallory	18-5314	18-5338	18-5376	18-5404-1	18-5251	18-5271	18-8802-1
230	1979	1981	8	Prestolite ①	18-5303	18-5347	18-5369	18-5407	18-5258	18-5277	18-8802-1
230	1975	1976	8	Mallory	18-5314	18-5338	18-5375	18-5411	18-5256	18-5272	18-8802-1
235	1971	1971	8	Mallory	18-5314	18-5338	18-5375	18-5411	18-5256	18-5272	18-8802-1
235	1975	1977	8	Prestolite ①	18-5303	18-5347	18-5369	18-5407	18-5258	18-5277	18-8802-1
240	1978	1978	8	Prestolite ①	18-5303	18-5347	18-5369	18-5407	18-5258	18-5277	18-8802-1
245	1975	1975	8	Mallory	18-5314	18-5338	18-5375	18-5411	18-5256	18-5272	18-8802-1
250	1970	1974	8	Mallory	18-5314	18-5338	18-5375	18-5411	18-5256	18-5272	18-8802-1
250	1979	1979	8	Prestolite ①	18-5303	18-5347	18-5369	18-5407	18-5258	18-5277	18-8802-1
260	1975	1976	8	Mallory	18-5314	18-5338	18-5375	18-5411	18-5256	18-5272	18-8802-1
260	1979	1981	8	Mallory	18-5314	18-5338	18-5376	18-5404-1	18-5251	18-5271	18-8802-1
260	1979	1981	8	Prestolite ①	18-5303	18-5347	18-5369	18-5407	18-5258	18-5277	18-8802-1
290 JET	1974	1975	8	Mallory	18-5314	18-5338	18-5375	18-5411	18-5256	18-5272	18-8802-1
305	1977	1979	8	Mallory	18-5314	18-5338	18-5375	18-5411	18-5256	18-5272	18-8802-1
305	1980	1981	8	Mallory	18-5314	18-5338	18-5376	18-5404-1	18-5251	18-5271	18-8802-1
305	1981	1981	8	Prestolite ①	18-5303	18-5347	18-5369	18-5407	18-5258	18-5277	18-8802-1
350	1977	1979	8	Mallory	18-5314	18-5338	18-5375	18-5411	18-5256	18-5272	18-8802-1
350	1980	1981	8	Mallory	18-5314	18-5338	18-5376	18-5404-1	18-5251	18-5271	18-8802-1
350	1981	1981	8	Prestolite ①	18-5303	18-5347	18-5369	18-5407	18-5258	18-5277	18-8802-1
454	1977	1979	8	Mallory	18-5314	18-5338	18-5375	18-5411	18-5256	18-5272	18-8803-2
454	1980	1981	8	Mallory	18-5314	18-5338	18-5376	18-5404-1	18-5251	18-5271	18-8803-2
454	1981	1981	8	Prestolite ①	18-5303	18-5347	18-5369	18-5407	18-5258	18-5277	18-8803-2

① Clip down distributor cap ② Screw down distributor cap

 <p>MP28890 IGNITION LANAYARD Replaces: 176288 Fits: 1996 - Up</p>	 <p>MP28880 LANAYARD Replaces: 432230 Fits: 1995-Older</p>	 <p>18-5225 SPARK PLUG WIRE KIT Kit Includes 25 ft. Roll of 7 MM Hypalon Ignition Wire With a Metallic Core and a Large Assortment of Three Different End Fittings.</p>	 <p>18-5222 IGNITION WIRE Silicone Core 100' Spool 8mm</p>
 <p>18-5226 IGNITION WIRE Metallic Core 100' Spool 7mm Hypalon</p>	<p>PKG. OF 10</p>  <p>18-5224 18-5224-9② SPARK PLUG WIRE TERMINAL Replaces: Mercury 20121 OMC 510364</p>	<p>PKG. OF 10</p>  <p>18-5750 18-5750-9② UNIVERSAL SPARK PLUG BOOT Supplied complete w/Terminal Connector Replaces: OMC 581027, 580339</p>	 <p>18-5752 UNIVERSAL SPARK PLUG BOOT 8mm</p>

③ Priced per Package

PREMIUM MARINE IGNITION WIRES

Sierra's MAGFORCE Ignition Wires are "Electronics Friendly" protecting all of your electronic devices and electronic engine controls from RFI and EMI while delivering the maximum amount of voltage. Exact fit design ensures easy installation and years of trouble - free service.

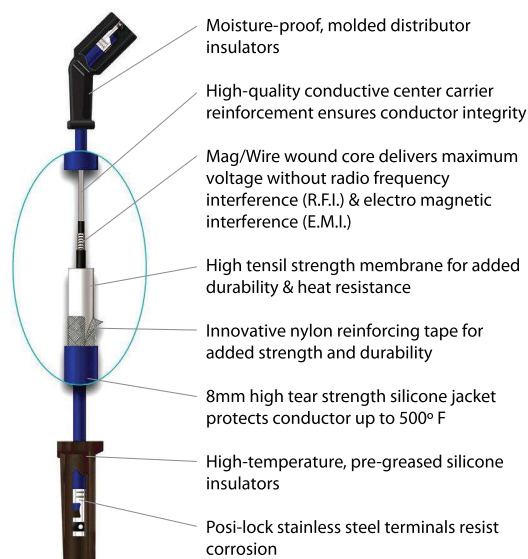

APPLICATION CONTINUED ON NEXT PAGE

OMC MARINE IGNITION WIRES APPLICATION

Model	Cyl.	Distributor	Year Start	Year End	Plug Wire Set
2.3L	4	Mallory	1987	1990	18-8807-1
2.3L	4	Prestolite	1990	1990	18-8807-1
2.5L	4	Delco	1981	1986	18-8800-1
3.0L	4	Delco	1982	1990	18-8800-1
3.0L	4	Delco EST	1990	1998	18-8833-1
3.8L	6	Prestolite	1981	1985	18-8801-1
4.3L	6	Prestolite ②	1985	1990	18-8801-1
4.3L	6	Prestolite	1991	1993	18-8801-1
4.3L	6	Delco EST	1994	1998	18-8835-1
5.0L (GM)	8	Prestolite ①	1979	1982	18-8802-1
5.0L (GM)	8	Mallory	1981	1988	18-8802-1
5.0L (GM)	8	Prestolite ②	1983	1988	18-8802-1
5.0L (Ford)	8	Prestolite ②	1989	1990	18-8806-1
5.0L (Ford)	8	Prestolite	1991	1996	18-8806-1
5.0L (Ford)	8	Ford HEI	1993	1996	18-8820-1
5.0L (GM)	8	Prestolite	1998	1998	18-8801-1
5.0L (GM)	8	Delco EST	1998	1998	18-8822-1
5.7L	8	Mallory	1982	1990	18-8802-1
5.7L	8	Prestolite ②	1982	1990	18-8802-1
5.7L	8	Prestolite ②	1991	1998	18-8802-1
5.7L	8	Delco EST	1996	1998	18-8822-1
5.8L	8	Prestolite ②	1989	1990	18-8842-1
5.8L	8	Prestolite ②	1991	1996	18-8842-1
5.8L	8	Ford HEI	1993	1996	18-8820-1
7.4L	8	Mallory	1988	1988	18-8802-1
7.4L	8	Prestolite ②	1988	1988	18-8802-1
7.4L	8	Distributorless	1990	1991	18-8843-1
7.4L	8	Delco EST	1995	1998	18-8832-1
7.5L	8	Prestolite ②	1987	1987	18-8803-2
7.5L	8	Prestolite ②	1987	1989	18-8803-2
8.2L	8	Mallory	1984	1985	18-8802-1
8.2L	8	Prestolite ②	1984	1985	18-8802-1
8.2L	8	Delco EST	1998	1998	18-8832-1

OMC MARINE IGNITION WIRES APPLICATION

Model	Cyl.	Distributor	Year Start	Year End	Plug Wire Set
80	4	ALL	1962	1968	18-8800-1
90	4	ALL	1962	1968	18-8800-1
100	4	Delco	1972	1973	18-8800-1
110	4	Delco	1964	1964	18-8800-1
120	4	Delco	1965	1981	18-8800-1
140	4	Delco	1973	1981	18-8800-1
170	8	Prestolite ①	1974	1974	18-8802-1
175	8	Prestolite ①	1975	1977	18-8802-1
185	8	Mallory	1967	1968	18-8802-1
185	8	Mallory	1978	1980	18-8802-1
185	8	Prestolite ①	1978	1980	18-8802-1
190	8	Prestolite ①	1974	1977	18-8802-1
200	8	Mallory	1979	1988	18-8802-1
200	8	Prestolite ①	1979	1981	18-8802-1
210	8	Mallory	1968	1970	18-8802-1
215	8	Mallory	1971	1971	18-8802-1
225	8	Mallory	1972	1976	18-8802-1
225	8	Mallory	1978	1978	18-8802-1
230	8	Mallory	1979	1981	18-8802-1
230	8	Prestolite ①	1979	1981	18-8802-1
230	8	Mallory	1975	1976	18-8802-1
235	8	Mallory	1971	1971	18-8802-1
235	8	Prestolite ①	1975	1977	18-8802-1
240	8	Prestolite ①	1978	1978	18-8802-1
245	8	Mallory	1975	1975	18-8802-1
250	8	Mallory	1970	1974	18-8802-1
250	8	Prestolite ①	1979	1979	18-8802-1
260	8	Mallory	1975	1976	18-8802-1
260	8	Mallory	1979	1981	18-8802-1
260	8	Prestolite ①	1979	1981	18-8802-1
290 JET	8	Mallory	1974	1975	18-8802-1
305	8	Mallory	1977	1979	18-8802-1

① Clip down cap ② Snap down cap

OMC MARINE IGNITION WIRES APPLICATION					
Model	Cyl.	Distributor	Year Start	Year End	Plug Wire Set
305	8	Mallory	1980	1981	18-8802-1
305	8	Prestolite ①	1981	1981	18-8802-1
350	8	Mallory	1977	1979	18-8802-1
350	8	Mallory	1980	1981	18-8802-1

OMC MARINE IGNITION WIRES APPLICATION					
Model	Cyl.	Distributor	Year Start	Year End	Plug Wire Set
350	8	Prestolite ①	1981	1981	18-8802-1
454	8	Mallory	1977	1979	18-8803-2
454	8	Mallory	1980	1981	18-8803-2
454	8	Prestolite ①	1981	1981	18-8803-2

① Clip down cap ② Snap down cap



18-5923
STARTER, PMGR, FORD
 PMGR Replacement for 18-5903; 302CID, 351CID Ford Engines
 Clockwise/Standard Rotation



18-5927
STARTER, PMGR, FORD
 PMGR Replacement for 18-5917, 2.3L Ford Starter.



18-6270
PERMANENT MAGNET I/O STARTER
 Replaces: 988013, 984536
 • Permanent Magnet
 • Heavy Duty
 • 12 Volt
 • 2 Bolt Mount
 • 1 Threaded Hole
 • CW Rotation
 • SAE J1171
 For: 460 Ford, OMC King Cobra



18-5919
STARTER
 Permanent magnet I/O starter
 For: Late model GM - 12 3/4" flywheel
 Replaces: 988217 SAEJ1171 1.7 KW



18-5920
STARTER
 Permanent Magnet
 For: 5.0 & 5.8 litre Ford engines.
 Clockwise/Standard Rotation
 Replaces: 987811, 3854190
 Replacement Solenoid: 18-6291

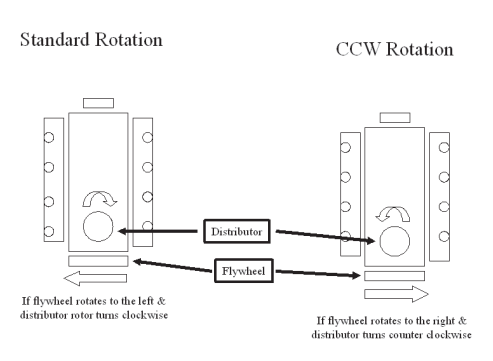

18-6276
STARTER
 Replaces: 984536, 988013
 • 12 Volt
 • CW Rotation
 • Threaded Top Hole in Housing
 • 460 Ford, OMC King Cobra

18-5911
STARTER
 (Heavy-Duty) (No Core)
 For GM engines, bottom mount straight across bolt pattern.
 Standard rotation clockwise. 100-245 HP — 1970-1978 (GM)
 Replaces: 981078, 982121, 983444, 983790, 985966
 Replacement Solenoid: 18-5837
 SAEJ1171



18-5907
STARTER
 (Heavy-Duty) (No Core)
 Top mount front entry starter for standard rotation GM and Ford engines.
 Replaces: 981289, 982202
 Replacement Solenoid: 18-5837
 SAEJ1171





18-5908
STARTER
 (Heavy-Duty) (No Core)
 Top mount front entry starter for reverse rotation
 GM and Ford engines. Counter-clockwise.
 Replaces: 981288, 982195, 984982, 986007
 Replacement Solenoid: 18-5837
 SAEJ1171



18-5910
STARTER
 (Heavy-Duty) (No Core)
 Small block GM V-6 & V-8 Engine with 14 1/4" flywheel and bottom mount,
 offset bolt pattern. For standard rotation engines. Clockwise. 1986-1992 - V-6,
 V-8 (GM) and 1990-1993 OMC King Cobra
 Replaces: 984456, 986505
 Replacement Solenoid: 18-5837
 SAEJ1171



18-5917
STARTER
 Replaces: 984628
 3 bolt mount - Late style 4" diameter case.
 Standard rotation engines
 For: Late model Ford V-8.
 Replacement Solenoid: 18-5801



18-5903
STARTER
 (No Core) (Clockwise)
 Bottom mount, two bolt pattern for standard
 rotation. Ford engines. Clockwise.
 Non-threaded top mounting hole. For threaded
 top, order 18-6276.
 Replaces: 980803, 981821
 Replacement Solenoid: 18-5801



18-5913
STARTER
 (Clockwise)
 Delco permanent magnet gear reduction 2 bolt
 starter 12V - 11 Tooth - Offset bolt pattern. Fits:
 Chevy Engines with 14" flywheels. 1.7 KW
 Replaces: 3854751 SAEJ1171

OMC STERNDRIVE/OMC COBRA STARTERS

ENGINE	YEAR	STARTER #	ENGINE	YEAR	STARTER #	ENGINE	YEAR	STARTER #
3.0L	1982-92	18-5911	165	1972-76	18-5911	245 JET	1972-74	18-5911
5.0L	1982-86	18-5911 ④	170	1974	18-5903	250	1979	18-5903
5.0L	1986-88	18-5910 ⑤	175	1975-77	18-5903	260	1975-76	18-5908 ①
2.5L	1982-86	18-5911	185	1967-68, 1978-80	18-5911	260	1975-76	18-5907 ②
3.8L	1981-86	18-5911	190	1974-77	18-5903	260	1979-81	18-5911
4.3L	1985-86	18-5911	200	1966-68, 1979-81	18-5911	262 CID	1989	18-5910
4.3L	1986-92	18-5910	210	1968-72	18-5911 ①	290	1975	18-5908 ③
5.7L	1982-86	18-5911	215	1971	18-5911	305 CID	1977-80,82	18-5908 ①
5.7L	1986-92	18-5910	225	1972-76, 1978	18-5911 ①	305 CID	1977-80,82	18-5907 ②
100	1972-73	18-5911	230	1975-76	18-5908 ①	350 CID	1977-80,82	18-5908 ①
110	1964	18-5911	230	1975-76	18-5907 ②	350 CID	1977-80,82	18-5907 ②
120	1965-81	18-5911	230	1979-81	18-5911	350 CID	1988-91	18-5910
140	1973-81	18-5911	235	1971	18-5911	370 CID	1988	18-5908
140 JET	1973	18-5911	235	1975-77	18-5903	454 CID	1977-80,82	18-5908 ①
150	1964-66	18-5911	240	1978	18-5903	454 CID	1977-80,82	18-5907 ②
155	1967-72	18-5911	245	1972-75	18-5911	454 CID	1990-92	18-5910
						502 CID	1992	18-5910

① Standard rotation engines.
 ② Opposite (Reverse) rotation engines.

③ Engines with model number suffix "R2" or "R3"
 ④ '86 Model engines with model number suffix "WB"

⑤ '86 Model engines with model number suffix "XS"

18-5717
STARTER BRUSH SET
 Replaces: Delco 1984462

18-8412
STARTER STUD EXTENDER
 Extends the solenoid stud on PMGR starters for applications that require more accessory wire connections.
 Threads: Female M8x1.25, Male 3/8"x16 UNC

18-5811
STARTER SOLENOID
 Replaces: 3850216
 For: PG 260 series starters, GM V6 & V8 (1983-Up)

18-5801D Display Package
18-5801
SOLENOID
 Replaces: 985064, 586842, 586730
 Grounded Base

18-5803
SOLENOID
 Replaces: 979774

18-5807
SOLENOID
 Replaces: 378444
 Prestolite SAW4206

18-6291
SOLENOID
 Replaces: 3854194 and Volvo Penta 3854194-2
 Fits: Ford Gear Reduction Starters on Late Model 5.0L, 5.8L, OMC and Volvo Penta

18-5814D Display Package
18-5814
SOLENOID
 Replaces: 172869, 581528
 12 Volt, Isolated Base

18-5808D Display Package
18-5808
SOLENOID
 Replaces: 395419, 582708

18-5812D Display Package
18-5812
SOLENOID
 Replaces: 985063

18-5837
SOLENOID
 Replaces: 985799, 986620
 Delco 1114531

18-5838
SOLENOID
 Replaces:
 Delco 1114356, 1114458

BATTERY CABLES
 Gauge cable with soldered lug terminals on each end to accept a 3/8" stud

Part No.	Size	Color	Gauge	Part No.	Size	Color	Gauge
BC88523	2'	red	4	BC88563	6'	red	2
BC88533	2'	black	4	BC88573	6'	black	2
BC88543	4'	red	2	BC88583	8'	red	1
BC88553	4'	black	2	BC88593	8'	black	1

① Items ending in "D" are Display Packaged - Regular number is Non-Display

STRINGER SOLENOID APPLICATION

HP	Year	Starter Brush	Starter Mounted Solenoid	Starter Solenoid	Tilt Solenoid	Trim Solenoid
80	1969	—	N/A	18-5808	N/A	18-5808
88	1964	—	N/A	18-5807	N/A	18-5807
90	1965-71	—	N/A	18-5808	N/A	18-5808
100	1972-73	18-5717	18-5838	18-5803	N/A	18-5803
110	1964	18-5717	18-5838	18-5807	N/A	18-5807
120	1965-71	18-5717	18-5838	18-5808	N/A	18-5808
120	1972-77	18-5717	18-5838	18-5803	18-5803	18-5803
120	1978-81	18-5717	18-5838	—	—	—
140	1973-77	18-5717	18-5838	18-5803	18-5803	18-5803
140	1978-81	18-5717	18-5838	—	—	—
145 ①	1973	—	18-5838	18-5803	N/A	N/A
150	1964	18-5717	18-5838	18-5807	N/A	18-5807
150	1965-66	18-5717	18-5838	18-5808	N/A	18-5808
155	1967-72	18-5717	18-5838	18-5808	N/A	18-5808
165	1972-76	18-5717	18-5838	18-5803	18-5803	18-5803
170	1974	—	N/A	18-5801	N/A	18-5803
175	1975-78	—	N/A	18-5801	N/A	18-5803
185	1967-68	18-5717	18-5838	18-5808	N/A	18-5808
185	1978-80	18-5717	18-5838	—	—	—
190	1974-78	—	N/A	18-5801	N/A	18-5803
200	1966-78	18-5717	18-5838	18-5808	N/A	18-5808
200	1979-81	—	18-5838	—	—	—
210	1968-70	18-5717	18-5838	18-5808	N/A	18-5808
210 ②	1970-72	18-5717	18-5838	18-5808	N/A	N/A
215	1971	18-5717	18-5838	18-5808	N/A	18-5808
225	1972	18-5717	18-5838	18-5808	N/A	18-5808
225	1973	18-5717	18-5838	18-5803	N/A	18-5808
225	1974-76	18-5717	18-5838	18-5803	N/A	18-5803
225	1978	18-5717	18-5838	—	—	—
225 ②	1973-74	18-5717	18-5838	18-5808	N/A	N/A
230 ②	1975-76	18-5717	18-5838	18-5803	N/A	N/A
230	1979-81	18-5717	18-5838	—	—	—
235	1971	18-5717	18-5838	18-5808	N/A	18-5808
235	1975-78	—	N/A	18-5801	N/A	18-5803
245	1972	18-5717	18-5838	18-5808	N/A	18-5808
245	1973	18-5717	18-5838	18-5803	N/A	18-5808
245	1974-75	18-5717	18-5838	18-5803	N/A	18-5803
245 ①	1972-75	18-5717	18-5838	18-5808	N/A	N/A
250 ②	1970-74	—	18-5838	18-5808	N/A	N/A
260 ②	1975-76	18-5717	18-5838	18-5803	N/A	N/A
260	1979-81	18-5717	18-5838	—	—	—
290 ①	1974-75	18-5717	18-5838	18-5808	N/A	N/A
305 ②	1977-82	18-5717	18-5838	—	N/A	N/A
350 ②	1977-82	18-5717	18-5838	—	N/A	N/A
454 ②	1977-82	18-5717	18-5838	—	N/A	N/A
2.5	1982	18-5717	18-5838	—	—	—
2.5	1983-86	18-5717	18-5837	—	—	—
3	1982	18-5717	18-5838	—	—	—
3	1983-86	18-5717	18-5837	—	—	—
3.8	1981-82	18-5717	18-5838	—	N/A	—
3.8	1983-86	18-5717	18-5837	—	N/A	—
4.3	1985-86	18-5717	18-5837	—	N/A	—
5	1982	18-5717	18-5838	—	—	—
5	1983-86	18-5717	18-5837	—	—	—
5.7	1982	18-5717	18-5838	—	—	—
5.7	1983-86	18-5717	18-5837	—	—	—

① Jet Drive

② Inboard

OMC COBRA SOLENOID APPLICATION

HP	Year	Starter Brush	Starter Mounted Solenoid	Starter Solenoid	Trim Solenoid
262	1989	N/A	18-5837	18-5812	N/A
350	1988	N/A	18-5837	18-5812	18-5812
350	1989	N/A	18-5837	18-5812	N/A
350	1990-91	N/A	18-5837	18-5801	N/A
351	1992	—	—	18-5801	N/A
370	1988	N/A	—	18-5812	18-5812
370	1989	N/A	—	18-5812	N/A
454	1990	—	—	18-5801	N/A
454	1991-92	N/A	18-5837	18-5801	N/A
460	1989-90	N/A	—	18-5801	N/A
502	1992	N/A	18-5837	18-5801	N/A
2.3	1987-88	N/A	—	18-5801	18-5812
2.3	1989-90	N/A	—	18-5801	N/A
2.5	1986	18-5717	18-5837	18-5812	18-5812
3	1986-88	18-5717	18-5837	18-5812	18-5812
3	1989-90	18-5717	18-5837	18-5812	N/A
3	1991-92	18-5717	18-5837	18-5801	N/A
4.3	1986-88	18-5717	18-5837	18-5812	18-5812
4.3 ①	1989-90	18-5717	18-5837	18-5812	N/A
4.3 ①	1990-92	18-5717	18-5837	18-5801	N/A
5	1986-88	18-5717	18-5837	18-5812	18-5812
5	1989-92	18-5717	—	18-5801	N/A
5.7	1986-88	18-5717	18-5837	18-5812	18-5812
5.7	1989	18-5717	18-5837	18-5812	N/A
5.7	1990-92	18-5717	18-5837	18-5801	N/A
5.8	1989-92	N/A	—	18-5801	N/A
7.5	1987	18-5717	—	18-5801	18-5812

① 1990 Models with 2 barrel carbs

② 1990 Models with 4 barrel carbs.

18-5711 VOLTAGE REGULATOR

Replaces: 383440
Prestolite: VSH-6201 AFY
12 Volt



Years	Model	Alternator or Generator
1964-66	110, 150 HP	ALK-6222, A, AYS
1967-81	80, 90, 120, 140, 155, 165, 175, 185, 190, 200, 210, 225, 230, 235, 250, 260 HP & 305, 350, 454 CID	ALK-6222, A, AY, Y, AYS ANK-65201S, Y ALK-6210, A

18-6261 ALTERNATOR

Replaces: 987774, 3857561, 3854182, 3854809, 3856600, 3860171
Fits: 3.0L, 4.3L, 5.7L, 7.4L (1995-98), 5.0L, 5.8L, 8.2L (1993-98)
For: Delco



18-6260 ALTERNATOR

OMC Cobra 12 Volt, 51 Amp, Internal Regulator, Negative Ground, Single Groove Pulley
For: Prestolite/Motorola



18-6841 ALTERNATOR

Replaces: 983424, 836, 247
For: 37-63A Marine Applications



18-5957 ALTERNATOR

Replaces: 982364
(3-Wire) (68 AMP)
Replaces Mando, Motorola and original equipment Delco. Uses same electrical connections and mounting method. Equipped with fan and drive pulley.
SAEJ1171





18-2192
ELECTRIC SHIFT CABLE
Replaces: 379628

ELECTRIC SHIFT CABLE APPLICATION	
Year	HP
1964	110 ②, 150
1965	120 ①, 150
1966	120 ①, 150, 200
1967	120 ①, 155, 185, 200
1968	120, 155, 185, 200, 210
1969-70	120, 155, 210
1971	120, 155, 215, 235
1972-73	100, 120, 155, 165, 225, 245
1974	120, 140, 165, 170, 190, 225, 245
1975	120, 140, 165, 175, 190, 225, 235, 245
1976	120, 140, 165, 175, 190, 225, 235
1977	120, 140, 175, 190, 235

① Heavy Duty ② SU12M, SUE 12M

③ 18-5705D



18-5705
POWER TRIM/FUEL
PUMP RELAY

Replaces: 582472,
584416, 586224

5 Terminal

Single Pull - Double Throw - 12 Volt
Open Contact: 40 Amps Resistive
30 Amps Conductive
Closed Contact: 20 Amps Resistive
15 Amps Conductive



18-6257
TILT/TRIM MOTOR
Replaces: 983195, 982957
1982-85 Models with hydraulic engine lifts for pump assembly



18-6754
TILT MOTOR
Replaces: 382138
Prestolite ETK 4102, ETK 4001, ETK 4101
(All Models 1963-77)



18-6755
TILT MOTOR
Replaces: 982706, 982058
Prestolite EVD 4001, EVD 4002
(All Models Except 2.5L, 3.0L - 1978-85)



18-6764
TILT/TRIM MOTOR
Replaces: 982073,
983318, 982069
For: OMC Stringer and Cobra
"Select Trim" 3-Wire Connection
1979-85 Stern Drive (2.5L & 3.0L)



18-6779
TRIM MOTOR
Replaces: 986280, 3853945
For: 1990 & 1994 King Cobra Trim System



18-6814
TRIM MOTOR
Replaces: 984356
OMC Cobra



18-6823
WIRING HARNESS
Replaces: Universal
Converts 3-wire Tilt and Trim motors to 2-Wire design



18-6950
18-6950-9①
POWER TILT FUSE
(50 amp)
Replaces: 982019



18-9802
TIMING LIGHT
Self-powered accurate
up to 10,000 RPM's



18-7601
AIR CHARGE
TEMPERATURE SENSOR
Replaces: 3854158
8 cyl
5.0L, 5.8 L, EFI (1994-96)



18-7684
MAP SENSOR
Replaces: 3850396
For: 4.3L TBI(1996-98), 5.0L TBI(1998),
5.7L TBI(1996-98), 7.4L(1995-98),
8.2L(1998)



18-7677
KNOCK SENSOR
Replaces: 3850357



18-7679
KNOCK SENSOR
Replaces: 3854905



18-7703
KNOCK SENSOR
Replaces: 3854512



18-7689
FUEL INJECTOR
Replaces: 3855182

③ Items ending in "D" are Display Packaged - Regular number is Non-Display

ALL SIERRA CARBURETORS INCLUDE BASE GASKET

- Precision remanufactured to meet or exceed OEM specifications
- Re-calibrated and re-engineered to maximize fuel efficiency and performance
- All carburetors are flow tested throughout the entire throttle range
- Fuel mixture and idle settings are pre-set to ensure that only minor idle and choke adjustments are necessary during installation
- All bases are resurfaced and throttle shaft bushings replaced



18-7635
CARBURETOR
(REMANUFACTURED)
300 CFM Holley 2V
Use replacement gasket [18-0360](#)



18-7636
CARBURETOR
(REMANUFACTURED)
500 CFM Holley 2V
Use replacement gasket [18-0994](#)



18-7637
CARBURETOR
(REMANUFACTURED)
600 CFM Holley 4V
(Includes gasket)



18-7638
CARBURETOR
(REMANUFACTURED)
600 CFM Holley 4V-side inlet



18-7640
CARBURETOR
(REMANUFACTURED)
Universal Q-jet with electric choke
Use replacement gasket [18-0462](#)



18-7605-1
CARBURETOR
4 Barrel Rochester
Replaces: 382821, 383766, 384194
Remanufactured
Use replacement gasket [18-2948](#)
Use Carb Replacement Kit [18-7095](#)



18-7608-1
CARBURETOR
2 Barrel Rochester
Replaces: 381668, 980528, 982219, 982217
Remanufactured
Use replacement gasket [18-0356](#)
Use Carb Replacement Kit [18-7070](#)



18-7609-1
CARBURETOR
2 Barrel Rochester
Replaces: 382733, 980530, 982217, 984180, 381494, 772831
Remanufactured
Use replacement gasket [18-0356](#)
Use Carb Replacement Kit [18-7070](#)



18-7615-1
CARBURETOR
4 Barrel Rochester
Replaces: 981705, 982223, 983855, 981359, 981564, 985822, 981803, 981428
Remanufactured
Use replacement gasket [18-2948](#)
Use Carb Replacement Kit [18-7095](#)



18-7615N
Q-JET CARBURETOR
Replaces: 1347-816373A4, 1347-804624R1, 1347-804624R02
(Includes gasket)
Use Carb Replacement Kit [18-7095](#)



OMC STERN DRIVE CARBURETOR APPLICATION

Model	Year	OMC Carburetor #	MFG Carburetor #	Carb Code & Model	Part #
80	1968-69	382733, 772831	7028085, 17059053, 17086064, 17087311	R2, 2GC	18-7609-1
90	1970-71	382733, 772831	7028085, 17059053, 17086064, 17087311	R2, 2GC	18-7609-1
120 (400 Series)	1972-86	381668, 980528, 982219	7044186, 17059056	R2, 2GC	18-7608-1
140 (400 Series)	1973-85	979821, 980530, 982217, 984180	17086107	R2, 2GC	18-7608-1
155	1967-72	772831	7026180	R2, 2GC	18-7609-1
165	1972-76	979821, 980530	17086107	R2, 2GC	18-7609-1
185	1989	984180	17086064	R2, 2GC	18-7609-1
200	1966-68	381494	7025187	R2, 2GC	18-7609-1
210	1968-72	382821, 383766	7028282, 7028280	R4, 4MV	18-7605-1
215, 225, 230	1971-76	382821	7028280	R4, 4MV	18-7605-1
230 (800 Series)	1979-89	981705, 982223	17057290, 17059285, 17059286, 17086117	R4, 4MV	18-7615-1
245	1972-75	384194	7040284	R4, 4MV	18-7605-1
250	1970-74	384194	7040284	R4, 4MV	18-7605-1
260 (800 Series)	1975-76	384194	7040284	R4, 4MV	18-7605-1
260 (800 Series)	1979-89	982223	17057290, 17059285, 17059286, 17086117	R4, 4MV	18-7615-1
2.5L, 3.0L	1982-86	982219, 982217	17059056, 17059053	R2, 2GC	18-7608-1
3.0L	1987-90	984180	17086064	R2, 2GC	18-7608-1
3.8L (4V)	1979-85	983855	17082515, 17085010	R4, 4MV	18-7615-1
4.3L (4V)	1979-89	983855	17082515, 17085010	R4, 4MV	18-7615-1
5.0L (GM)(4V)	1979-89	982223	17057290, 17059285, 17059286, 17086117	R4, 4MV	18-7615-1
5.7L (4V)	1979-89	982223	17057290, 17059285, 17059286, 17086117	R4, 4MV	18-7615-1
305, 350 Cl, I/B	1977-83	981359, 982215, 981564, 982223	17057290, 17059285, 17059286, 17086117	R4, 4MV	18-7615-1
350 (4V)	1988-89	985822	17057290, 17059285, 17059286, 17086117	R4, 4MV	18-7615-1
454 Cl, I/B	1977-78	981803, 981428	17057290, 17059285, 17059286, 17086117	R4, 4MV	18-7615-1



18-7017
CARB KIT
 Replaces: 985052
 235 (5.8L Ford) 1989 7.5L/460 C.I. 1987-89
 (Contains Non-adjustable needles and seats)



18-7018
CARB KIT
 Replaces: 982352
 350 C.I. Inboard 1977-78



18-7070
CARB KIT
 Replaces: 383615, 982384



18-7071
CARB KIT
 Replaces: 380186



18-7072
CARB KIT
 Replaces: 979659, 384743



18-7080
CARB KIT
 Replaces: 979719



18-7081
CARB KIT
 Replaces: 982537, 982538
 (Contains adjustable needles and seats)



18-7086
CARB KIT
 Replaces: 984487



18-7095
CARB KIT
 Replaces: 983864, 383918

APPLICATION BEGINS ON PAGE 882



18-7096
CARB KIT
 Replaces: 982539, 85R-4541
 (Contains adjustable needles and seats)



18-7235
CARB KIT
 Replaces: 986783



18-7236
CARB KIT
 Replaces: 986782



18-7237
CARB KIT
 Replaces: 986784, 986799



18-7238
CARB KIT
 Replaces: 986796



18-7239
CARB KIT
 Replaces: 986800



18-7241
CARB KIT
 Replaces: 986804



18-7242
CARB KIT
 Replaces: 987313



18-7243
CARB KIT
 Replaces: 987315



18-7244
CARB KIT
 Replaces: 987317



18-7245
CARB KIT
 Replaces: 987319



18-7246
CARB KIT
 Replaces: 987438, 987440, 987485



18-7727
CARB KIT



18-7729
CARB KIT



18-7730
CARB KIT

APPLICATION BEGINS ON NEXT PAGE



18-7200
FLOAT
(Alcohol Resistant)
Replaces: 381389
Plastic



18-7201
FLOAT
(Alcohol Resistant)
Replaces: 383087, 983871
Brass



18-7206
NITROPHYL FLOAT
Nitrophenyl

CARBURETOR KIT/FLOAT APPLICATION

Model	Years	Mfg. Code	Carb. Model	Carb Kit	Float
80	1968-69	R2	2GC	18-7070	18-7200
90	1970-71	R2	2GC	18-7070	18-7200
100	1972-73	C1	RBS	18-7080	—
110	1964	R1	BC	18-7071	—
120	1965-71 (Dual Carb)	C1	RBS	18-7080	—
120	1972-85	R2	2GC	18-7070	18-7200
140	1973-85	R2	2GC	18-7070	18-7200
150	1964-65	R1	BC	18-7071	—
150	1965-66	C1	RBC	18-7080	—
155	1967-72	R2	2GC	18-7070	—
165	1972-76	R2	2GC	18-7070	18-7200
170	1974	H2	2300	18-7081	18-7206
175	1975-77	H2	2300	18-7081	18-7206
185	1978-81	R2	2GE	18-7086	18-7200
185	1989	H2	2300	18-7081	18-7206
190	1974-77	H2	2300	18-7081	18-7206
200	1966-68	R2	2GC,V	18-7070	—
200	1979-85	R2	2GE	18-7086	18-7200
200	1989	H2	2300	18-7081	18-7206
210	1968-72	R4	4MV	18-7072	18-7201
215	1971	R4	4MV	18-7072	18-7201
225	1972-76	R4	4MV	18-7072	18-7201
230	1975-76	R4	4MV	18-7072	18-7201
230	1979-89	R4	4MV	18-7095	18-7201
235	1975-77	H4	4160	18-7096	18-7206
235	1989	H4	4160	18-7017	—
240	1978	H4	4160	18-7017	—
245	1972-75	R4	4MV	18-7072	18-7201
250	1970-74	R4	4MV	18-7072	18-7201
250	1979	H4	4160	18-7017	—
260	1975-76	R4	4MV	18-7072	18-7201
260	1979-89	R4	4MV	18-7095	18-7201
290 JET	1974-75	R4	4MV	18-7072	18-7201
2.3L	1987-89	R2	2GE	18-7086	18-7200
2.5L	1982-85	R2	2GC	18-7070	18-7200
2.5L	1986-90	R2	2GE	18-7086	18-7200
2.5L	1986	R2	2GC	18-7070	18-7200
3.0L ②	1982-90	R2	2GC	18-7070	18-7200
3.0L/3.0L H.O.	1991-92	H-2	2300	18-7246	N/A
3.8L	1979-85	R2	2GE	18-7086	18-7200
4.3L	1986-89	R2	2GE	18-7086	18-7200
4.3L	1979-89	R4	4MV	18-7095	18-7201
4.3,4.3 H.O. ②	1990-92	H2	2300	18-7238	N/A
4.3,4.3 H.O. ③	1990-92	H4	4160	18-7237	N/A
4.3/262 ②	1989	R2	2GE	18-7086	18-7200
5.0L (GM)	1979-85	R2	2GE	18-7086	18-7200
5.0L (GM)	1979-89	R4	4MV	18-7095	18-7201

② For 2V Carburetors
③ For 4V Carburetors
④ For Engine Model 574APEPWS

⑥ For 1990 PWC Suffix Only
⑦ For Engine Model 574APERGD

① For Engine Model 744DPEAMH, 744DPPAMH
② For Engine Model 744CPEAMH, 824BPEAM

CARBURETOR KIT/FLOAT APPLICATION

Model	Years	Mfg. Code	Carb. Model	Carb Kit	Float
5.0L (FORD)	1989	H2	2300	18-7081	18-7206
5.0,5.0 H.O. ③	1989-90	H4	4160	18-7237	N/A
5.0,5.0 H.O. ②	1989-90	H2	2300	18-7236	N/A
5.0,5.0 H.O. ③	1991	H4	4160	18-7245	N/A
5.0,5.0 H.O. ②	1991	H4	4175	18-7244	N/A
5.0,5.0 H.O. ①	1992	H4	4150	18-7242	N/A
5.7L	1979-89	R4	4MV	18-7095	18-7201
5.7	1990-92	H4	4175	18-7239	N/A
5.7 LE ⑨	1991-92	H4	4175	18-7243	N/A
5.7 LE ④	1990	H4	4175	18-7239	N/A
5.8L	1989	H4	4160	18-7017	—
7.5L	1987-88	H4	4160	18-7017	—
305 C.I.I/B	1977-79	R2	2GE	18-7086	18-7200
305 C.I.I/B	1977-78	R4	4MV	18-7018	18-7201
305 C.I.I/B	1979-83	R4	4MV	18-7095	18-7201
350 C.I.I/B	1977-78	R4	4MV	18-7018	18-7201
350 C.I.I/B	1979-83	R4	4MV	18-7095	18-7201
350 ④ ③	1988-89	R4	4MV	18-7095	18-7201
350 ②	1988	R2	2GE	18-7086	18-7200
351 CID/5.8L H.O.	—	H4	4010, R50483A, R84046A (F1JL-9510-EA)	18-7727	—
351 CID/5.8L	—	H4	4160, R9393A, R9394A, R50399A, R50399-1A	18-7729	—
351 CID/5.8L	—	H4	4160C, R80434A	18-7730	—
454 C.I.I/B	1977-78	R4	4MV	18-7072	18-7201
454,454 H.O. ①	1991-92	H4	4150	18-7242	N/A
454,454 H.O. ②	1990-92	H4	4150	18-7241	N/A
460 C.I.	1987-88	H4	4160	18-7017	—
460	1989-90	H4	4160	18-7235	N/A

- ② For 2V Carburetors
- ③ For 4V Carburetors
- ④ For Engine Model 574APEPWS

- ⑥ For 1990 PWC Suffix Only
- ⑨ For Engine Model 574APERGD

- ① For Engine Model 744DPEAMH, 744DPPAMH
- ② For Engine Model 744CPEAMH, 824BPEAM

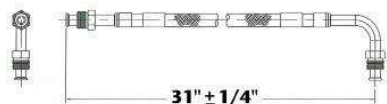

**18-8114
FUEL LINE HOSE**

For fuel pump to carburetor connection. Replaces copper or steel tubing 3/8" X 31" PTFE composite hose with 5/8"-18 male inverted flare straight one end, 5/8"-18 90° one end. SAE J1527 type A1

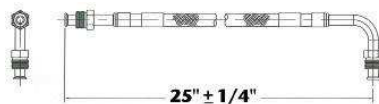

**18-8115
FUEL LINE HOSE**

For fuel pump to carburetor connection. Replaces copper or steel tubing 3/8" X 25" PTFE composite hose with 5/8"-18 male inverted flare straight one end, 5/8"-18 90° one end. SAE J1527 type A1



ALL SIERRA FUEL PUMPS INCLUDE MOUNTING GASKET



**18-7256
FUEL PUMP**
Flange I.D. # 6790
For: GM (4 & 6 cyl.)153, 230, 250, 292



**18-7258
FUEL PUMP**
Replaces: 380986
Flange I.D. # 40001, M643
For: GM (V-6) 225, PB-V215



**18-7265
FUEL PUMP**
Flange I.D. # 41412, M73018
For: GM (V-8) 305, 350, 400

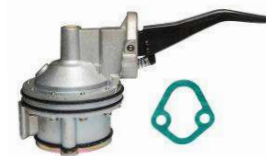

**18-7267
FUEL PUMP**
Replaces: 982063
Flange I.D. # 40778, M73016
(Includes gasket)
For: Ford (V-8) 302



**18-7268
FUEL PUMP**
Replaces: 981650
Flange I.D. #41415
For: GM (V-8) 305, 307, 350, 400
Dual diaphragm sight glass required.



**18-7278
FUEL PUMP**
Replaces: 985602, 985603, 982240
Flange I.D. #M60032
Uses filter 18-7860
For: GM (4 & 6 cyl.) 153, 181, 250, 224, 225



**18-7289
FUEL PUMP**
Replaces: 982997
Flange I.D. # 60201
(Includes gasket)
For: GM (V-6) 262/4.36

FUEL PUMP APPLICATION

Model	Years	Pump #	Model	Years	Pump #
2.5	1982-85	18-7278	185	1978-80	18-7268
5	1982-88	18-7268	190	1974-77	—
5.7	1982-92	18-7268	200	1979-81	18-7268
100	1972-73	18-7278	225	1978	18-7268
110	1964	18-7278	230	1979-81	18-7268
120	1965-80	18-7278	235	1975-77	—
140	1973-81	18-7278	240	1978	—
140 Jet Drive	1973	18-7278	245 Jet Drive	1973	18-7278
150	1964	—	250	1979	—
150 Model HU-13EM	1965	—	260	1979-81	18-7268
150 Except HU-13EM	1965	—	305 CID IB	1979-82	18-7268
165	1972-76	18-7278	350 CID IB	1979-82	18-7268
170	1974	—	350	1988-91	18-7268
175	1975-77	—			



18-7326
ELECTRIC FUEL PUMP
 Replaces: 3858261, 3857986, 3850809, 3854620



18-7330
ELECTRIC FUEL PUMP
 Replaces: 3857650, 3855958, 3854280, 987620, 988037



18-7331
ELECTRIC FUEL PUMP
 Replaces: 3850810



18-7229
FLAME ARRESTOR
 Replaces: 986865, 981566

ELECTRIC FUEL PUMP APPLICATION

Year	Engine	Application	OE #	#s Superseded from	Part #
1992-94	262/4.3L	Low Pressure	3858261	3850809, 3850810, 3857985	18-7326
1997-98	350/5.7L, 454/7.4L, & 502/8.2L	Engines w/MPI - High Pressure	3857650		18-7330
1996	454/7.4L & 502/8.2L	Engines w/MPI - High Pressure	3857650		18-7330
1993-94	4.3L thru 5.8L	Low pressure electric fuel pump	3858261	3850809	18-7326
1992-1994	454/7.4L & 502/8.2L	GM Mark V Eng. - Low Pressure	3858714	3850810, 3857985	18-7331

- UNIVERSAL DESIGN -

FUEL WATER SEPARATOR BRACKETS



Bracket Type	Part #	Bracket Type	Part #
1/4" Stainless Steel	18-7777	1/4" Aluminum	18-7853-1
3/8" Stainless Steel	18-7776	3/8" Aluminum	18-7775

FUEL WATER SEPARATOR KITS



21 MICRON FILTER KITS FOR CARBURETED ENGINES

Kit Type	Part #	Micron Rating	Contents
1/4" Aluminum (Short Filter)	18-7848-1	21	1 - 18-7844 filter & 1 18-7853-1 bracket, 2 - 18-4256 1/4" pipe plugs
1/4" Aluminum Bonus Pack (Contains spare filter)	18-7848-2	21	2 - 18-7844 filter & 1 18-7853-1 bracket, 2 - 18-4256 1/4" pipe plugs
1/4" Aluminum (Tall Filter)	18-7852-1	21	1 - 18-7845 filter & 1 18-7853-1 bracket, 2 - 18-4256 1/4" pipe plugs
1/4" Aluminum Bonus Pack (Contains spare filter)	18-7852-2	21	2 - 18-7845 filter & 1 18-7853-1 bracket, 2 - 18-4256 1/4" pipe plugs
3/8" Aluminum (Tall Filter)	18-7775-1	21	1 - 18-7845 filter & 1 18-7775 bracket, 2 - 18-4264 3/8" pipe plugs
1/4" Stainless Steel (Tall Filter)	18-7777-1	21	1 - 18-7845 filter & 1 18-7777 bracket, 2 - 18-4256 1/4" pipe plugs
3/8" Stainless Steel (Tall Filter)	18-7776-1	21	1 - 18-7845 filter & 1 18-7776 bracket, 2 - 18-4264 3/8" pipe plugs

10 MICRON FILTER KITS FOR FUEL INJECTED ENGINES



Kit Type	Part #	Micron Rating	Contents
1/4" Aluminum (Short Filter)	18-7983-1	10	1 - 18-7944 filter & 1 18-7853-1 bracket 2 - 18-4256 1/4" pipe plugs
1/4" Aluminum Bonus Pack Contains spare filter	18-7983-2	10	2 - 18-7944 filter & 1 18-7853-1 bracket 2 - 18-4256 1/4" pipe plugs
1/4" Aluminum (Tall Filter)	18-7982-1	10	1 - 18-7945 filter & 1 18-7853-1 bracket 2 - 18-4256 1/4" pipe plugs
1/4" Aluminum Bonus Pack Contains spare filter	18-7982-2	10	2 - 18-7945 filter & 1 18-7853-1 bracket 2 - 18-4256 1/4" pipe plugs
1/4" Aluminum (High Capacity Filter)	18-7966-1	10	1 - 18-7866 filter & 1 18-7853-1 bracket 2 - 18-4256 1/4" pipe plugs
3/8" Aluminum (Tall Filter)	18-7986-1	10	1 - 18-7945 filter & 1 18-7775 bracket 2 - 18-4264 3/8" pipe plugs
1/4" Stainless Steel (Tall Filter)	18-7984-1	10	1 - 18-7945 filter & 1 18-7777 bracket 2 - 18-4256 1/4" pipe plugs
3/8" Stainless Steel (Tall Filter)	18-7985-1	10	1 - 18-7945 filter & 1 18-7776 bracket 2 - 18-4264 3/8" pipe plugs



10 MICRON FILTER KITS WITH DRAIN BOWLS

Sierra AquaVue™ and metal bowl separator filters allow water to be drained from the filter to extend service life. Use the AquaVue™ bowl for outboard, above deck installations. USCG regulations require the use of the flame resistant metal bowl below deck.

Kit Type	Part #	Micron Rating	Contents
1/4" Aluminum w/ metal drain bowl	18-7951	10	1 - 18-7919 filter & 1 18-7853-1 bracket 1 - 18-7924 metal bowl 2 - 18-4256 1/4" pipe plugs
1/4" Stainless Steel w/ metal drain bowl	18-7938	10	1 - 18-7919 filter & 1 18-7777 bracket 1 - 18-7924 metal bowl 2 - 18-4256 1/4" pipe plugs

• Display Packaged

COMPACT BRACKET AND SEPARATOR KIT - FOR SMALL OUTBOARDS AND FRESH WATER APPLICATIONS

18-7774
COMPACT ALUMINUM BRACKET



18-7965-1
10 MICRON COMPACT SEPARATOR KIT
Contains:
1 - 18-7774 bracket
1 - 18-7865 filter



REPLACEMENT FILTERS



UNIVERSAL DESIGN

10 MICRON REPLACEMENT FILTERS			21 MICRON REPLACEMENT FILTERS		
Part #	Description		Part #	Description	
18-7944	Short - 3.875"		18-7844	Short - 3.875"	
18-7945	Long - 4.35"		18-7845	Long - 4.35"	
18-7866	High Capacity - 6"				
18-7865	Compact 10 Micron				

REPLACEMENT FILTERS FOR OMC

10 MICRON REPLACEMENT FILTERS			21 MICRON REPLACEMENT FILTERS		
Part #	Description	Replaces	Part #	Description	Replaces
18-7946	OMC thread	OMC 502905	18-7846	OMC thread	OMC 502905
18-7989	Cobra EFI	OMC 502906	18-7789	Cobra EFI	OMC 502906



10 MICRON REPLACEMENT FILTERS AND KITS WITH DRAIN BOWLS

REPLACEMENT FILTERS			FILTER & BOWL KITS		
Part #	Description	Replaces	Part #	Description	
18-7919	Spin on replacement	Racor S3213	18-7929	Filter & Metal Bowl	
18-7920	Spin on replacement	OMC 771839 Racor S3214	18-7941-1	Filter & AquaVue™ Bowl OMC style	Contains: 18-7919 filter, 18-7924 bowl
18-7947	Spin on replacement Fits - 120RRAC01	Racor S3240	18-7943	Filter & Metal Bowl OMC style	Contains: 18-7920 filter, 18-7922-1 bowl
18-7948	Spin on replacement Fits - 320RRAC01	Racor S3227			
18-7949	Spin on replacement Fits - 660RRAC02	Racor S3232			Contains: 18-7920 filter, 18-7924 bowl
REPLACEMENT BOWLS			REPLACEMENT ELEMENTS		
Part #	Description		Part #	Description	Replaces
18-7924	Metal Collection Bowl		18-7930	1977-83 Fuel system with add on filter kit	OMC 173326



18-7792
FUEL FILTER
Replaces: 910641, 3855104
Fits: OMC 3.0L (1996-98), 3.8L/170 (1981)



18-7854
FUEL FILTER
Replaces: 984491, 311684
Rochester 17078904



18-7855
FUEL FILTER
Replaces: 983870, 910139
Rochester 17068453

• Display Packaged



18-7717
FILTER ELEMENT
For: Rochester 2 bbl & 4 bbl Carburetors



18-7859
FUEL FILTER
Replaces: 908034
For: Most GM Inline 4 & 6 cycle;
Ford and GM V-8's up to 400 HP



18-7860
FUEL FILTER
Replaces: 381690, 312456
with AC Fuel Pumps
For: Inline 4 & 6 cycle engines



18-7861
REPLACEMENT CANISTER AND FILTER
Replaces: 981911



18-7862
FUEL FILTER ELEMENT
For Fuel Filter
(Includes Gasket)
Replaces: 982230



18-7964-1
TRANSMISSION FILTER KIT



18-8072
FUEL ELBOW
3/8" Hose Barb with
3/8" NPT Thread
Replaces: 174177
90°



18-8074
HOSE BARB
NPT Thread
3/8" with 1/4"
Replaces: 173312

PKG. OF 10



SNAPPER CLAMPS			
Part No.	O.E. No.	Range	Size
18-8020 ①	322652	.538 - .608	8
18-8021 ①	911616	.597 - .665	10
18-8034 ①	329654	.670 - .780	12
18-8200 ①	322653	.360 - .406	2
18-8201 ①	124249	.410 - .468	4
18-8202 ①	322654	.475 - .536	6
18-8203 ①	329653	.750 - .875	14
18-8204 ①	324825	.875 - .975	19



18-5894
OIL PRESSURE LIGHT SWITCH
Replaces: 0379948

ALL SIERRA WATER PUMPS ARE BI-DIRECTIONAL



18-3593
CIRCULATING WATER PUMP
Replaces: 0984360, 0986779, 380640, 3854017, 3858340
Uses gasket **18-0327** (Included)
For: GM Inline (4 & 6 Cylinder)



18-3577-2
CIRCULATING WATER PUMP
Replaces: GM 6269358, OMC 987447,
983296, 986074, 3854118
For: GM Big Block



18-3578
CIRCULATING WATER PUMP
Replaces: 984876



18-3584
CIRCULATING WATER PUMP
Replaces: 982517, 3853796, 982515
Uses gasket **18-0147** (Included)
For: Ford V8 small block



18-3599-2
CIRCULATING WATER PUMP
Replaces: 382218, 980477, 985429, 3853850
For: GM V-6 & small block V-8 engines
Uses gasket **18-0981** (included)

① This product is priced per piece. To order priced per package, please add -9 to the part number.

WATER CIRCULATING PUMP APPLICATION

Model	Year	Part #	Model	Year	Part #	Model	Year	Part #
2.3	1987-90	-	165	1972-76	18-3593	245	1972-75	18-3599-2
2.5	1982-86	18-3593	175	1977	18-3584	245		
3	1982-92	18-3593	185	1967-80	18-3599-2	Jet Drive	1972-75	18-3599-2
3.8	1981-86	18-3599-2	190	1977	18-3584	250		
4.3	1985-92	18-3599-2	200	1979-81	18-3599-2	Inboard	1970-74	18-3599-2
5	1982-88	18-3599-2	210	1968-70	18-3599-2	250	1979	18-3593
5	1989-92	18-3593	210			260		
5.7	1982-92	18-3599-2	Inboard	1970-72	18-3599-2	Inboard	1975-76	18-3599-2
5.8	1989-92	18-3593	215	1971	18-3599-2	260	1979-81	18-3599-2
100	1972	18-3593	225	1972-78	18-3599-2	262	1989	18-3599-2
100	1973	18-3599-2	225			290		
120	1965-69	18-3593	Inboard	1973-74	18-3599-2	Jet Drive	1974-75	18-3599-2
120	1972	18-3593	230			305 CID IB	1977-82	18-3599-2
120	1973-74	18-3599-2	Inboard	1975-76	18-3599-2	350 CID IB	1977-82	18-3599-2
120	1975-81	18-3593	230	1979-81	18-3599-2	350	1988-92	18-3599-2
140			235	1971	18-3599-2	351	1992	18-3584
Jet Drive	1973	18-3593	235	1977	18-3584	454 CID IB	1977-80	18-3577-2
140	1973-81	18-3593	240	1978	18-3584	454 CID IB	1982	18-3599-2

18-3058
IMPELLER
Replaces: 983895



18-3086
IMPELLER
Replaces: 379475, 777130



18-30585
IMPELLER
Replaces: 3854072
Fits: King Cobra (1992-1995)



IMPELLER APPLICATION

Model	Years	Impeller	Model	Years	Impeller
2.3	1987-1990	18-3058 ①	170	1974	18-3086
2.5	1986	18-3058	175	1975-1977	18-3086
3	1986-1992	18-3058 ①	185	1967-1968	18-3086
4.3	1986-1992	18-3058	185	1978-1984	18-3086
5	1986-1992	18-3058	190	1974-1977	18-3086
5.7	1986-1992	18-3058 ②	200	1966-1968	18-3086
5.8	1989-1992	18-3058	200	1979-1984	18-3086
50FAPLJVB, 50FAPJVN	1993	18-3058	210	1968-1972	18-3086
50FAPRJVB	1993	18-3058	215	1971	18-3086
50FACPMDA, 50FAGPMDM	1994	18-3060	225	1972-1976	18-3086
50FAGPMDA, 50FAGPMDM	1994	18-3060	225	1978	18-3086
50FAGPMDM	1994	18-3060	230	1975-1976	18-3086
58FACPMDA, 58FAGPMDM	1994	18-3060	230	1979-1981	18-3086
58FAGPMDA, 58FAGPMDM	1994	18-3060	232AMFTC	1987	18-3086
58FAPLJVB, 58FAPJVN	1993	18-3058	232AMRGDE, 232AMRGDP	1988	18-3058
58FAPRJVB, 58APRJVN	1993	18-3058	232APFTC	1987	18-3058
7.5	1987	18-3058	232APRGDE, 232APRGDP	1988	18-3058
80	1968-1969	—	232APSRC	1987	18-3058
88	1964	—	232BMRMED, 232BMRMEF	1989	18-3058
90	1965-1968	—	232BPRMED, 232BPRMEF	1989	18-3058
90	1970-1971	—	235	1971	18-3088
100	1972-1973	18-3086	235	1975-1977	18-3088
110	1964	— ③	240	1978	18-3088
110	1964	18-3086 ④	245	1972-1975	18-3086
120	1965-1967	— ③	250	1970-1974	18-3086
120	1965-1967	18-3086 ④	250	1979	18-3086
120	1968-1984	18-3086	252AMKWB, 252APKWB	1986	18-3058
140	1973-1984	18-3086	260	1975-1976	18-3086
150	1964-1966	18-3086	260	1979-1984	18-3086
155	1967-1972	18-3086	262	1989	18-3058
165	1972-1976	18-3086	262AMLMED, 262APRMED	1989	18-3058

① Except models originally equipped with short impeller or retrofitted with short impeller kit

② Except 1992 5.7LE models ③ Standars pump ④ Heavy duty pump

Model	Years	Impeller	Model	Years	Impeller
302AMARJ, 302AMARY	1987	18-3058	434AMKWB	1986	18-3058
302AMFTC	1987	18-3058	434AML PWS	1990	18-3058
302AMKWB	1986	18-3058	434AMWXS	1986	18-3058
302AMRGDP	1988	18-3058	434AMLGDP	1988	18-3058
302AMRMED	1989	18-3058	434APARY, 434APFTC	1987	18-3058
302APARY, 302APFTC	1987	18-3058	434APKWB	1986	18-3058
302APKWB	1986	18-3058	434APLAMH	1992	18-3058
302APRGDP	1988	18-3058	434APLJVB, 434APLJVN	1993	18-3058
302APRMED	1989	18-3058	434APLRGD	1991	18-3058
302APSRC, 302ARSRY	1987	18-3058	434APRAMH	1992	18-3058
302BMRAMH, 302BMRAMK	1992	18-3058	434APRGDP	1988	18-3058
302BMRJVB	1993	18-3058	434APRJVB, 434APRJVN	1993	18-3058
302BMRRGD	1991	18-3058	434APRPWS	1990	18-3058
302CCPMDA, 302CGPMDA	1994	18-3060	434APRRGD	1991	18-3058
302CMHUB	1995	18-3060	434APSRC, 434APSRV	1987	18-3058
302CMNCA, 302CMNCS	1996	18-3060	434APWXS	1986	18-3058
302CMRAMH, 302CMRRAMK	1992	18-3058	454	1977	18-3086
302CMRJVB	1993	18-3058	454	1990-1991	18-3058
302CMRRGD	1991	18-3058	460	1988-1990	18-3058
302CPHUB	1995	18-3060	460AML MED	1989	18-3058
302CPNCA "A" SUFFIX MODELS	1996	18-3060	460APRMED	1989	18-3058
302CPNCS "A" SUFFIX MODELS	1996	18-3060	502ACPMDA	1994	18-3060
302CPRAMH, 302CPRAMK	1992	18-3058	502AGPMDA	1994	18-3060
302CPRJVB	1993	18-3058	502AMLGDP	1988	18-3058
302CPRRGD	1991	18-3058	502AML MED	1989	18-3058
302DCMMDA, 302DGMMDA	1994	18-3060	502AML PWS, 502ANLPWS	1990	18-3058
305	1977-1978	18-3086	502APLAMH, 502APLAMK	1992	18-3058
350	1977-1978	18-3086	502APLJVB	1993	18-3058
350	1988-1991	18-3058	502APLRGD	1991	18-3058
350AML MED, 350APRMED	1989	18-3058	502APRAMH, 502APRAMK	1992	18-3058
370	1988	18-3058	502APRGDP	1988	18-3058
432ACMMDA, 432ACPMDA	1994	18-3060	502APRJVB	1993	18-3058
432AGMMDA, 432AGPMDA	1994	18-3060	502APRMED	1989	18-3058
432AMARY, 432AMFTC	1987	18-3058	502APRPWS	1990	18-3058
432AMKWB	1986	18-3058	502APRRGD	1991	18-3058
432AMLGDP	1988	18-3058	502BPRAMH, 502BPRAMK	1992	18-3058
432AML MED	1989	18-3058	502BPRJVB	1993	18-3058
432AML PWS	1990	18-3058	502BPRMED	1989	18-3058
432AMWXS	1986	18-3058	502BPRPWS	1990	18-3058
432APARY, 432APFTC	1987	18-3058	502BPRRGD	1991	18-3058
432APKWB	1986	18-3058	504AMARY, 504AMFTC	1987	18-3058
432APLAMH	1992	18-3058	504AMKWB	1986	18-3058
432APLJVB, 432APLJVN	1993	18-3058	504AMLGDP	1988	18-3058
432APLRGD	1991	18-3058	504AMWXS	1986	18-3058
432APRAMH	1992	18-3058	504APARY, 504APFTC	1987	18-3058
432APRGDE, 432APRGDP	1988	18-3058	504APKWB	1986	18-3058
432APRJVB, 432APRJVN	1993	18-3058	504APRGDP	1988	18-3058
432APRMED	1989	18-3058	504APWXS	1986	18-3058
432APRPWS	1990	18-3058	572ACPMDA, 572AGPMDA	1994	18-3060
432APRRGD	1991	18-3058	574AMFTC	1987	18-3058
432APSRC, 432APSRV	1987	18-3058	574AMKWB	1986	18-3058
432APWXS	1986	18-3058	574AMLGDP	1988	18-3058
434AMARY, 434AMFTC	1987	18-3058	574AML MED	1989	18-3058

① Except models originally equipped with short impeller or retrofitted with short impeller kit

② Except 1992 5.7LE models ③ Standars pump ④ Heavy duty pump

Model	Years	Impeller	Model	Years	Impeller
574AML PWS	1990	18-3058	584AML MED	1989	18-3058
574AMWXS	1986	18-3058	584AML PWS	1990	18-3058
574APARY	1987	18-3058	584APL AMH, 584APL AMK	1992	18-3058
574APEPWS	1990	18-3058	584APL JVB	1993	18-3058
574APERGD	1991	18-3058	584APL RGD	1991	18-3058
574APFTC	1987	18-3058	584APR AMH, 584APR AMK	1992	18-3058
574APKWB	1986	18-3058	584APR JVB	1993	18-3058
574APL AMH	1992	18-3058	584APR MED	1989	18-3058
574APL RGD	1991	18-3058	584APR PWS	1990	18-3058
574APR AMH	1992	18-3058	584APR RGD	1991	18-3058
574APR GDP	1988	18-3058	744APEPWS	1990	18-3058
574APR MED	1989	18-3058	744APERGD, 744APERGF	1991	18-3058
574APR PWS	1990	18-3058	744BPERGD	1991	18-3058
574APR RGD	1991	18-3058	754APEPWS	1990	18-3058
574APSRC	1987	18-3058	754APFTC, 754APSRC	1987	18-3058
574APWXS	1986	18-3058	754BPFTC, 754BPSRC	1987	18-3058
574BML GDP	1988	18-3058			
574BPEPWS	1990	18-3058			
574BPERGD	1991	18-3058			
574BPR GDP	1988	18-3058			
584ACPMDA, 584AGPMDA	1994	18-3060			

- ① Except models originally equipped with short impeller or retrofitted with short impeller kit
- ② Except 1992 5.7LE models
- ③ Standars pump
- ④ Heavy duty pump



18-3108
IMPELLER KEY
 Replaces: 308928
 Fits: Sterndrive models (1968-85)
 For: Stringer Drive Impeller 18-3086



18-3111
WATER PUMP SHAFT SEAL
 Replaces: 907774
 I/O 1972-86
 EXCEPT COBRA



18-4833
WATER PASSAGE HOUSING (LOWER UNIT)
 Replaces: 915720
 Fits: OMC Cobra (1986-93) without cone clutch



18-4837
WATER PASSAGE COVER
 Replaces: 911734
 Fits: OMC Cobra (1986-93) without cone clutch



18-3119
WATER PUMP HOUSING
 Replaces: 983298



18-3206
WATER PUMP HOUSING
 Replaces: 984744
 For: OMC Cobra



18-3145
PUMP LINER
 Replaces: 911844



18-3121
IMPELLER PLATE
 Replaces: 911703
 COBRA



18-3141
IMPELLER PLATE
 Replaces: 313176
 110-260 HP I/O 1968-86
 EXCEPT COBRA



18-3502
WATER PUMP VENT HOSE
 Replaces: 912614
 Fits: OMC Cobra (1986-93) without cone clutch

① **18-3212-1D** 



**18-3212-1
IMPELLER
REPAIR KIT**
Replaces: 984461

— CONTAINS —

Part #	Description	O.E.M. #	Qty.
18-2541	O-Ring	911704	1
18-2916	Water Pump Housing Gasket	911702	1
18-3058	Impeller	983895	1
18-3121	Impeller Plate	911703	1
18-3145	Pump Liner	911844	1



**18-3286
IMPELLER
REPAIR KIT**
1964-86
EXCEPT COBRA

— CONTAINS —

Part #	Description	O.E.M. #	Qty.
18-7135	O-Ring	310584	1
18-3141	Plate	313176	1
18-7129	O-Ring	314491	1
18-3111	Rubber Seal	907774	1
18-3086	Impeller	379475	1
18-7158	O-Ring	310585, 310967	1



**18-3386
WATER PUMP KIT**
Replaces: 983218
1964-86
EXCEPT COBRA

— CONTAINS —

Part #	Description	O.E.M. #	Qty.
18-7135	O-Ring	310584	1
18-3141	Plate	313176	1
18-7129	O-Ring	314491	1
18-3086	Impeller	379475	1
18-3111	Rubber Seal	907774	1
18-3119	Impeller Housing	983298	1
18-7158	O-Ring	310585, 310967	1



**18-3348
COMPLETE WATER PUMP KIT**
Replaces: 984461
For: All OMC Cobra Drives-2.3 (1987-90), 2.5 (1986), 3.0(1986-93), 4.3(1986-93), 4.6(1989), 5.0(1986-93), 5.7(1986-93), 5.8 (1989-93), 7.5(1987-89)
Uses impeller **18-3058**



**18-3469
WATER PUMP REPAIR KIT**
Replaces: 3854661
For: King Cobra Drives (1992-1995)



**18-3349
WATER PUMP HOUSING KIT**
For: All OMC Cobra Drives-2.3 (1987-90), 2.5 (1986), 3.0(1986-93), 4.3(1986-93), 4.6(1989), 5.0(1986-93), 5.7(1986-93), 5.8 (1989-93), 7.5(1987-89)



**18-5897
SENDER**
Replaces: 980613
3/8" — 18 NPT
For: Mercruiser Vazer



**18-5898
SENDER**
Replaces: 171960
1/2" — 14 NPT



**18-5899
OIL PRESSURE
SENDER**
Replaces: 982650



**18-3554
THERMOSTAT**
Replaces: 383307
160°



**18-3558
THERMOSTAT**
Replaces: 982554, 3853799
160°

① **18-3653D** 



**18-3653
THERMOSTAT KIT**

— CONTAINS —

Part #	O.E. #	Desc.
18-3554	383307	Thermostat
18-2858	314809	Manifold Gasket
18-2917	3701777 (GM)	Thermostat Gasket
18-0398	3852111	Thermostat Gasket

APPLICATION FOR THERMOSTATS/KITS ON NEXT PAGE

① Items ending in "D" are Display Packaged - Regular number is Non-Display



① 18-3670D

Display Package

18-3670 THERMOSTAT KIT

Fits: 2.5L & 3.0L (1982-88)

— CONTAINS —

Part #	O.E.#	Desc.
18-3558	982554	Thermostat
18-2858	314809	Thermostat Housing Cover Gasket
18-0929	313416	Thermostat Gasket



① 18-3676D

Display Package

18-3676 THERMOSTAT KIT

140°

For: 7.4L (1994-98), 8.2L (1998)

— CONTAINS —

Part #	O.E.#	Desc.
18-7170	3852071	O-Ring
18-0398	3852111	Thermostat Gasket
—	3853983	Thermostat



① 18-3677D

Display Package

18-3677 THERMOSTAT KIT
160°

— CONTAINS —

Part #	O.E.#	Desc.	
18-7170	3852071	O-Ring	
18-0398	3852111	Thermostat Gasket	
—	3856961	Thermostat	
HP	Year	HP	Year
4.3L	1994-97	5.8L	1994-97
4.3 HO	1991-97	5.8 (EFI)	1993-97
5.0 L	1994-97		

THERMOSTAT AND THERMOSTAT KIT APPLICATION

Model	Years	Thermostat	Thermostat Kit	Model	Years	Thermostat	Thermostat Kit
90	1970	18-3554	18-3653	250	1970-73	18-3554	18-3653
100	1972-73	18-3554	18-3653	250	1979	18-3554	18-3653
120	1969-80	18-3554	18-3653 ①	260	1979-81	18-3554	18-3653
120	1980-81	18-3558	18-3670 ②	262	1989	18-3554	—
140	1973-80	18-3554	18-3653 ①	305	1977-82	18-3554	18-3653
140	1980-81	18-3558	18-3670 ②	350	1977-82	18-3554	18-3653
155	1969-72	18-3554	18-3653	350	1989	18-3554	—
165	1972-76	18-3554	18-3653	351	1992	18-3554	—
170	1974	18-3554	18-3653	454	1977-82	18-3554	18-3653
175	1975-77	18-3554	18-3653	460	1989	18-3554	—
185	1978-80	18-3554	18-3653	2.5L	1982-88	18-3558	18-3670
190	1974-77	18-3554	18-3653	3.0L	1982-88	18-3558	18-3670
200	1979-81	18-3554	18-3653	3.8L	1981-85	18-3554	18-3653
210	1969-72	18-3554	18-3653	4.3L	1985-86	18-3554	18-3653
215	1971	18-3554	18-3653	4.3L	1989-92	18-3554	—
225	1971	18-3554	18-3653	5.0L	1982-88	18-3554	18-3653
230	1979-81	18-3554	18-3653	5.0L	1989-92	18-3554	—
235	1971	18-3554	18-3653	5.7L	1982-88	18-3554	18-3653
235	1975-77	18-3554	18-3653	5.7L	1989	18-3554	—
240	1978	18-3554	18-3653	5.8L	1989-92	18-3554	—
245	1972-75	18-3554	18-3653	7.5L	1988	18-3554	18-3653

① 1980 Models with "C" suffix only

② 1980 Models with "C1" suffix only

SINGLE DIAMETER HOSE



18-70021
MOLDED HOSE
3/4" ID



18-70704
MOLDED HOSE
1 1/4" ID



18-70924
MOLDED HOSE
1 3/4" ID



18-71218
MOLDED HOSE
1" ID



18-71337
MOLDED HOSE
1 3/4" ID

STRAIGHT HOSE



18-75100
MOLDED HOSE
Straight 48"
1" ID



18-75125
MOLDED HOSE
Straight 48"
1 1/4" ID

① Items ending in "D" are Display Packaged - Regular number is Non-Display

V-BELTS

- 1 High strength synthetic cords resist shockload failure. Their low stretch properties assure uniform performance over the life of the belt.
- 2 The compression section is a special rubber compound that assures smooth and even transfer of load forces to the cords.
- 3 Cogs are molded to precise engineering tolerances to improve flexibility and maintain cord support. Cog geometry provides a large area for air circulation to keep the belt cool and prevent damaging heat build up in the cushion section.
- 4 Rubber edges maintain positive, no-slip contact with pulley grooves for reliable energy transfer.



BELT SIZE LISTING BY NUMBER

Part #	Effective Length (Inches)	Top Width (Inches)	Part #	Effective Length (Inches)	Top Width (Inches)	Part #	Effective Length (Inches)	Top Width (Inches)
18-15290	29	29/64	18-15405	40 1/2	29/64	18-15460	46	29/64
18-15300	30	29/64	18-15410	41	29/64	18-15470	47	29/64
18-15325	32 1/2	29/64	18-15415	41 1/2	29/64	18-15480	48	29/64
18-15345	34 1/2	29/64	18-15430	43	29/64	18-15495	49 1/2	29/64
18-15370	37	29/64	18-15435	43 1/2	29/64	18-15500	50	29/64
18-15380	38	29/64	18-15440	44	29/64	18-15520	52	29/64
18-15390	39	29/64	18-15450	45	29/64	18-15550	55	29/64
18-15400	40	29/64	18-15455	45 1/2	29/64			

V-BELT INTERCHANGE

HOSE INTERCHANGE

OMC #	Part #	Part #	OMC #	Sierra #	Part #	Sierra #	Part #
310953	18-15460	18-15380	910414	18-71337	312781	18-75100	913488
311046	18-15440	18-15400	311606	18-75100	910305	18-75125	912793
311606	18-15400	18-15415	910343	18-75100	912424		
908929	18-15455	18-15435	912509				
909818	18-15500	18-15440	311046				
909971	18-15460	18-15450	914787				
910343	18-15415	18-15455	908929				
910414	18-15380	18-15460	310953				
912418	18-15500	18-15460	909971				
912509	18-15435	18-15500	909818				
912714	18-15520	18-15500	912418				
914787	18-15450	18-15520	912714				

V-BELT APPLICATION

Model	Year	Water Alternator	Pump	Power Steering	Model	Year	Water Alternator	Pump	Power Steering				
100	1972-73	18-15400	18-15400	—	262 KING COBRA	1989	—	*18-15380	18-15455				
110	ALL	18-15440	18-15440	—	305	1977-84	18-15440	18-15440/ *18-15455 or *18-15500	—				
120	1965-81	18-15400	18-15400	—			350	1977-84	18-15440	18-15440/ *18-15455 or *18-15500	—		
140	1982-87	18-15400	18-15400	—					350 KING COBRA	1988-90	18-15455	18-15455	—
165	1972-76	18-15400	18-15400	—							350 KING COBRA	1988-90	18-15470
170	1974	18-15400	18-15400	—			454	1977-82	18-15455	18-15455/ *18-15500	—		
175	1975-77	18-15400	18-15400	—	454 KING COBRA	—	—	18-15470	18-15380				
185 W/O PS	1978-84	18-15440	18-15440	—	460 KING COBRA	1988	18-15460	18-15460	18-15520				
185 W/ PS	1978-84	18-15460	18-15460	18-15460	888	—	18-15435	18-15435	—				
190	1974-77	18-15400	18-15400	—	2.3L	1987-90	18-15435	18-15435	18-15435				
200 W/O PS	1979-81	18-15440	18-15440	—	2.5L W/O PS	1982-87	18-15415	18-15415	—				
200 W/ PS	1979-81	18-15460	18-15460	18-15460	2.5L W/ PS	1982-87	18-15400	18-15400	18-15460				
210	1970-71	18-15440	18-15440	—	3.8L W/O PS	1982-90	18-15400	18-15400	—				
215	1971	18-15440	18-15440	—	3.8L W/ PS	1982-90	—	*18-15380	18-15455				
225	1972-84	18-15440	18-15440	—	5.0L W/O PS	1982-90	18-15455	18-15455	—				
230,260	1975	18-15440	18-15440/ *18-15455	—	5.0L W/ PS	1982-90	—	*18-15380	18-15455				
230,260	1979-81	18-15440	18-15440	—	7.5L	1987	18-15460	18-15460	18-15520				
230,260	1979-81	18-15460	18-15460	18-15460									
235	1971	18-15440	18-15440	—									
235	1975-77	18-15400	18-15400	—									
240	1978-84	18-15400	18-15400	—									
250	1979	18-15400	18-15400	—									
262 KING COBRA	1989	18-15400	18-15400	—									

* W/ SEA WATER PUMP

Fits GM 181 CID 3.0L, 4 Cylinder Fits Most 141 Models

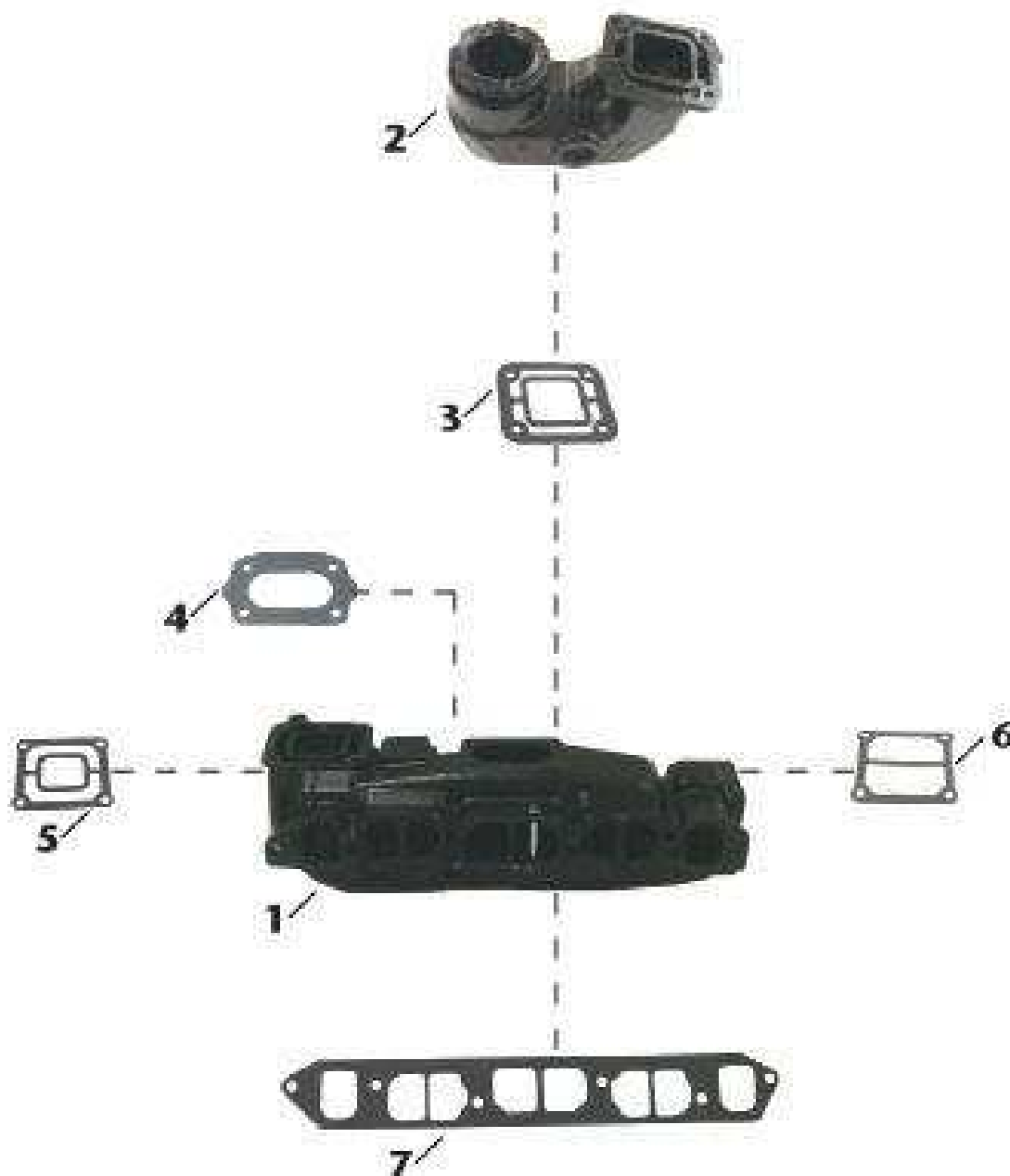

Item No	Description	OE No.	Application
1	18-1901 MANIFOLD	982490, 980083, 984054	GM 181 cu.in. 3.0L , 4 Cylinder. Fits most 140 models.
2	18-1922 MANIFOLD ELBOW	987784	Use with Manifold: 18-1901 ; Elbow Gasket: 18-2875-1
3	18-2875-1 ELBOW GASKET	3850495	Use with Elbow: 18-1922
4	18-0937 CARBURETOR GASKET	315055	Use with Manifold: 18-1901
5	18-2861-1 END PLATE GASKET	311121	Use with Manifold: 18-1901
6	18-0114-1 END PLATE GASKET	907761	Use with Manifold: 18-1901
7	18-1204-1 MANIFOLD GASKET	912164	Use with Manifold: 18-1901

Fits GM Small Block V8 305-350 cu. in. 1979-1989

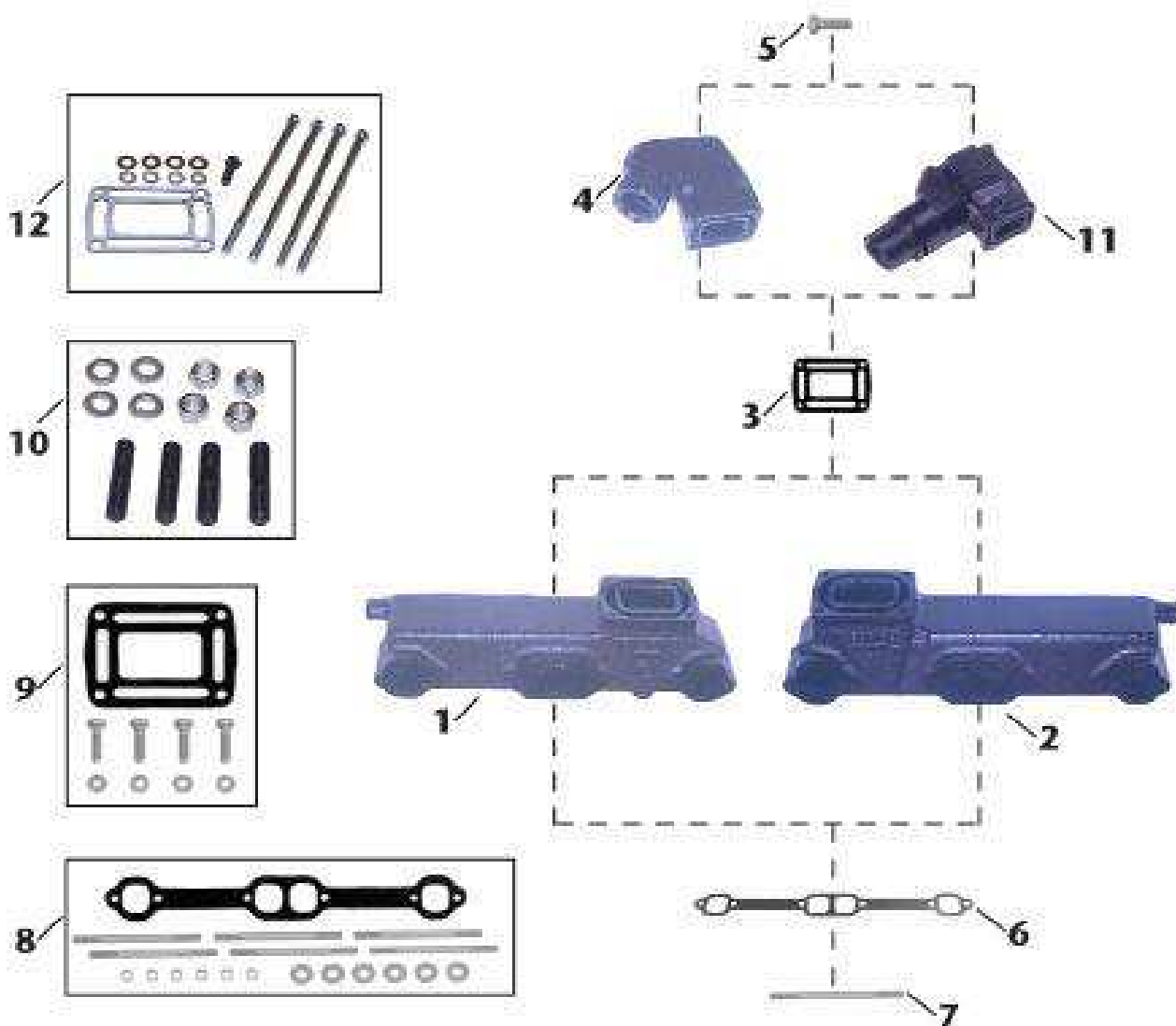

Item No	Description	OE No.	Application
1	18-1902 MANIFOLD (STARBOARD)	912441	GM Small Block (V8) 305-350 cu.in. (1979-1989)(Starboard) Use with Manifold Gasket: 18-2949 , Mounting Kit: 18-8502
2	18-1903 MANIFOLD (PORT)	912442	GM Small Block (V8) 305-350 cu.in. (1979-1989)(Port). Use with Manifold Gasket: 18-2949 , Mounting Kit: 18-8502
3	— ELBOW GASKET	909786	Use with Elbow: 18-1921 ; Mounting Kit: 18-8534 .
4	18-1921 MANIFOLD ELBOW	909863	Use with Manifold: 18-1902 , 18-1903 . Mounting Kit: 18-8534 .
5	NSS MOUNTING BOLT	N/A	Included in 18-8534 mounting kit.
6	18-2949 MANIFOLD GASKET	96306	Use with Manifold: 18-1902 , 18-1903 . Included in 18-8502 mounting kit.
7	NSS MOUNTING STUD	N/A	Included in 18-8502 mounting kit.
8	18-8502 MOUNTING KIT	N/A	Use with Manifold: 18-1902 , 18-1903 . Includes 18-2949 manifold gasket.
9	18-8534 MOUNTING KIT	N/A	Use with Elbow: 18-1921 .
10	18-8553 HARDWARE KIT	N/A	Hardware only for Elbow 18-1921 .
11	18-1909-1 MANIFOLD ELBOW	N/A	Use with Elbow Gasket: 18-0943-2
12	18-8507 MOUNTING KIT	N/A	Use with Manifold Elbow: 18-1909-1

Fits GM Small Block V8 305-350 cu. in.



Item No	Description	OE No.	Application
1	18-1986-1 MANIFOLD	3857723	GM Small Block (V8) 305-350 cu.in. Use with Manifold Gasket: 18-2949 ; Mounting Kit: 18-8502 .
2	— ELBOW GASKET	909786	Use with Elbow: 18-1909-1 . Included in 18-8507 mounting kit.
3	18-1909-1 MANIFOLD ELBOW	913784, 3855270, 3850459, 3857944	Use with Manifold: 18-1986-1 ; Mounting Kit: 18-8507 .
4	NSS MOUNTING BOLT	N/A	Included in 18-8507 mounting kit.
5	18-8216 HOSE FITTING	N/A	3/4" - 14NPT X 1" Hose (Corrosion Resistant Brass Fitting)
6	18-4461 HOSE FITTING	N/A	3/4" - 14NPT X 1" Hose (Corrosion Resistant Brass Fitting)
7	18-8215 HOSE FITTING	N/A	3/4" - 14NPT X 3/4" Hose (Corrosion Resistant Brass Fitting)
8	18-2949 MANIFOLD GASKET	96306	Use with Manifold: 18-1986-1 . Included in 18-8502
9	NSS MOUNTING STUD	N/A	Included in 18-8502 mounting kit.
10	18-8502 MOUNTING KIT	N/A	Use with Manifold 18-1986-1 . Includes 18-2949 manifold gasket.
11	18-8507 MOUNTING KIT	N/A	Use with Elbow: 18-1909-1 . Includes 18-0943-2 elbow gasket.

SIERRA MANIFOLDS ARE PAINTED, PACKAGED AND LEAK TESTED



**18-1901
MANIFOLD**
Replaces: 984054
Fits 181 CID model 140
and 3.0L (1973 - 1989)
Use with: Exhaust Manifold Gasket **18-1204-1** &
Elbow Gasket **18-2875-1**
***For Exploded View - See PAGE 894**



**18-1898
MANIFOLD**
Port & Starboard
Replaces: Barr CHVA-1-84, Marine Power 0991-110
Fits 454 cu.in. GM big block V8 engines
Use with:
Exhaust Manifold Gasket: **18-0418**
***For Exploded View - See Pages 636-637**



**18-1997-1
EXHAUST MANIFOLD**
Port & Starboard
Replaces Barr CHV-1-83 Universal Center Riser Manifold
FITS: GM 283, 305, 307 and 350 CID engines
Use with:
Exhaust Manifold Gasket Set: **18-0604**
***For Exploded View - See Pages 638-639**



**18-1998-1
EXHAUST MANIFOLD**
Port & Starboard
Replaces: Barr FM-1-83
Universal Center Riser Manifold
FITS: Ford 302 and 351 CID engines
Use with:
Exhaust Manifold Gasket Set: **18-0603**
***For Exploded View - See Pages 640-641**



**18-1986-1
MANIFOLD**
Port & Starboard
Replaces: 3852374, 3857723
For: GM Small Block V8 305-350 ci
Use with:
Exhaust Manifold Gasket: **18-2949**
Mounting Kit: **18-8502**



**18-1902
MANIFOLD**
Replaces: 912441
V-8 - STARBOARD SIDE
Fits most GM V-8 small blocks with end riser
Use with:
Mounting Kit: **18-8502**



**18-1903
MANIFOLD**
Replaces: 912442 V-8 - PORT SIDE
Fits most GM V-8 small blocks with end riser
Use with:
Mounting Kit: **18-8502**



**18-1904
MANIFOLD**
Port & Starboard
Replaces: 980959, 980572 V-8 - EITHER SIDE
Fits most Ford V-8 302 & 351W with end riser
Use with:
Exhaust Manifold Gasket: **18-0183-1** or **18-2896-1**
(See Application Chart)



18-1848
MANIFOLD
 Replaces: 3852338, 3857656, 914899
 Fits: 4.3L V-6



18-1991
30° EXHAUST ELBOW ADAPTER
 Replaces: Barr 200089P
 For use with 3" I.D. Exhaust Hose
 Use with:
 Manifold Riser: **18-1999**



18-1992-1
80° EXHAUST ELBOW
 Replaces: Barr 200087P
 For 3" I.D. Exhaust Hose (As used in 18-1987 Exhaust Manifold Conversion Kit)



18-1921
ELBOW MANIFOLD
 Replaces: 909863
 V-8
 Fits most GM V-8 small blocks
 Use with:
 Manifold: **18-1902, 18-1903**
 Elbow Gasket: **18-0943-2**
 Mounting Kit: **18-8534**



18-1922
ELBOW MANIFOLD
 Replaces: 987784, 916096, 0740120, 3850799, 910380
 4 CYL.
 Fits most 140 HP 3.0L (181 CID)
 Use with:
 Manifold: **18-1901**
 Elbow Gasket: **18-2875-1**



18-1909-1
RISER
 Replaces:
 OMC 913784, 3855270, 3850456, 3857944
 VOLVO 3855270-9, 3857944-7, 3863061, 3856444
 OMC Riser, 4" outlet 7°: Fits many GM & Ford center rise manifolds.
 Use with:
 Manifold: **18-1986-1**
 Riser Gasket: **18-0943-2**
 Mounting Kit: **18-8507**



18-1939
RISER
 Replaces: Barr 20-0100, Marine Power 0992-593 Barr, Indmar and Marine Power Ford Small Block V8 302-351cu.in., GM Small Block V8 305-350cu.in., GM Big Block V8 454cu.in.
 Use with:
 Manifold: **18-1997-1, 18-1998-1**
 Riser Gasket: **18-2854-1** open or **18-0476-1** blocked
 Mounting Kit: **18-4364** open or **18-8535** blocked
 4" hose



18-1907
RISER
 Replaces: Barr 20-0102, Indmar 53-2009, 53-2018, Barr and Indmar Ford Small Block V8 302-351cu.in.
 Use with:
 Manifold: **18-1997-1, 18-1998-1**
 Riser Gasket: **18-2854-1** open or **18-0476-1** blocked
 Mounting Kit: **18-4364** open or **18-8535** blocked
 3" hose



18-1999
EXHAUST MANIFOLD RISER
 Replaces: Barr 20-0082
 Use with:
 Manifold: **18-1997-1** or **18-1998-1**
 Riser Gasket: **18-2854-1** open
 3 1/2" hose
 Comes with **18-4364** open
 If blocked mounting kit is required use **18-8535**
 Replaces: Barr 20-0082-P



18-4009
MANIFOLD END PLATE
 Replaces: 910384



PIPE PLUGS

Part #	Thread Size
18-4256	1/4"
18-4257	1/4"
18-4258	3/4"
18-4263	1/8" - 27 NPT
18-4264	3/8" - 18 NPT

56507 Pipe Sealant with Teflon® is recommended for use on plug threads.



18-4461
HOSE BARB
 3/4" - 14 NPT X 1" Hose
 Corrosion Resistant Brass Fitting













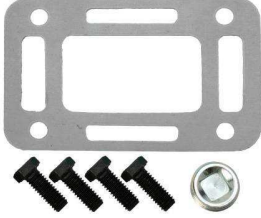



18-8216
HOSE BARB
 3/4" - 14 NPT X 1" hose barb
 Fits: OMC - In-Line 6 Cylinders

① **18-4218D** Display Package



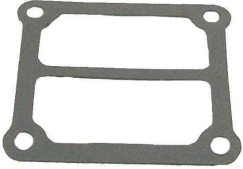

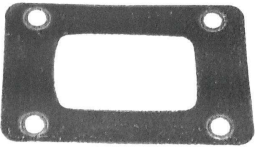



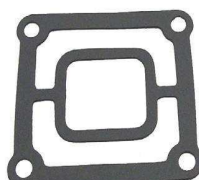

18-4218
BRASS DRAIN COCK
 Replaces: 379957
 1/4"
18-3223-9 Bulk Pack of 12

① Items ending in "D" are Display Packaged - Regular number is Non-Display

 <p>18-4363 MOUNTING PACKAGE Replaces: Barr FM-1-83-P Use with: Manifold: 18-1998-1</p>	 <p>18-4364 (Open) MOUNTING PACKAGE Replaces: Barr 20-0082-P Use with: Riser: 18-1999, 18-1939, 18-1907</p>	 <p>18-8502 MOUNTING KIT OMC GM Small Block V8 305-350cu.in. (1979-89) OMC/Volvo GM Small Block 305-350cu.in. Used with: Manifolds: 18-1931-1, 18-1902 & 18-1903</p>
 <p>18-8507 MOUNTING KIT Replaces: Barr CM-20-6674JP OMC/Volvo GM Small Block V8 305-350cu.in. Used with: Riser: 18-1909-1</p>	 <p>18-8534 MOUNTING KIT OMC GM Small Block V8 305-350cu.in. (1979-1989) and multiple application Ford and GM Risers Used with: Riser: 18-1921</p>	 <p>18-8535 (Blocked) MOUNTING KIT Barr, Indmar and Marine Power Ford Small Block V8 302-351cu.in., GM Small Block V8 305-350cu.in., GM Big Block V8 454cu.in. Used with: Risers: 18-1939, 18-1999, and 18-1907</p>
 <p>18-8536 MOUNTING KIT Barr, Indmar and Marine Power GM Small Block V8 305-350cu.in. Used with: Manifold: 18-1997-1</p>	 <p>18-8538 MOUNTING KIT Barr and Indmar Ford Small Block V8 302-351cu.in. Used with: Manifold: 18-1998-1, 18-1904</p>	 <p>18-8553 MOUNTING KIT Used with: Exhaust Elbow: 18-1921</p>
 <p>18-2779 EXHAUST HOSE Replaces: 3852696</p>	 <p>18-2781 EXHAUST HOSE Replaces: 3852742</p>	 <p>18-0114-1 MANIFOLD END GASKET Replaces: 907761</p>
 <p>18-0183-1 EXHAUST MANIFOLD GASKET Replaces: 908717, 916262, 3852455, 3853742 Use with: Manifold: 18-1958, 18-1962, 18-1904, 18-1998-1, 18-1996, 18-1979</p>	 <p>18-0476-1 (Blocked) RISER GASKET Replaces: Barr 01-0105 Indmar & Marine Power Ford Small Block V8 302-351cu.in. Used with: Risers: 18-1939, 18-1999 and 18-1907</p>	<p>PKG. OF 2</p>  <p>18-0943-2 18-0943-2-9^① EXHAUST ELBOW GASKET Replaces: 909786, 3850496 Used with: Riser: 18-1909-1</p>

① Priced per Package

<p>PKG. OF 2</p>  <p>18-2850-1 18-2850-9^① EXHAUST ELBOW GASKET Replaces: 908935</p>	<p>PKG. OF 2</p>  <p>18-2854-1 18-2854-9^① EXHAUST RISER GASKET Replaces: Barr 01-0107 Use with: Mounting Kit: 18-8535 Risers: 18-1999, 18-1939, 18-1907</p>	<p>PKG. OF 2</p>  <p>18-2861-1 18-2861-9^① EXHAUST ELBOW GASKET Replaces: 311121</p>
<p>PKG. OF 2</p>  <p>18-2875-1 18-2875-1-9^① EXHAUST ELBOW GASKET Replaces: 3850495, 908013 Used with: Elbow: 18-1922</p>	 <p>18-2896-1 MANIFOLD GASKET Replaces: 311068 For GM 4 cyl. 153 cu.in. Early models 110/120 where the carb. linkage mounts to the rear of the engine Use with: Manifold: 18-1904</p>	
<p>PKG. OF 2</p>  <p>18-2902-1 18-2902-1-9^① MANIFOLD GASKET Replaces: 909314 Use with: Manifold: 18-1997-1, 18-1986-1, 18-1902, 18-1903</p>	<p>PKG. OF 2</p>  <p>18-2949 18-2949-9^① MANIFOLD GASKET Replaces: Barr CHV-47-000 Use with: Manifold: 18-1997-1</p>	
 <p>18-0603 EXHAUST MANIFOLD GASKET SET For: Ford 302/351 CID Eng. Use with: Manifold: 18-1998-1</p>	 <p>18-0604 EXHAUST MANIFOLD GASKET SET For: GM 305/350 CID Eng. Use with: Manifold: 18-1997-1</p>	

① Priced per Package

MANIFOLD/MANIFOLD GASKET APPLICATION

Year	Horsepower	Exhaust Manifold	Exhaust Elbow	Manifold Mount Kit	Elbow Mount Kit	Manifold Gasket	Elbow Gasket
1997-98	5.0/5.7L	18-1986-1	18-1909-1	18-8502	18-8507	18-2902-1	18-0943-2
1994-97	5.8L (Ford)	—	—	—	—	18-0183-1	18-0943-2
1994-97	7.4L (GM)	—	—	—	—	18-0418	18-0943-2
1991-93	3.0 Liter	—	18-1922	—	—	—	18-2875-1
1992-93	4.3/4.3 HO	—	18-1909-1	—	18-8507	—	18-0943-2
1993	5.0/5.0 HO/5.8 Liter	—	18-1909-1	—	18-8507	18-0183-1	18-0943-2
1993	5.0 & 5.8 EFI	—	18-1909-1	—	18-8507	18-0183-1 ^②	18-0943-2
1993	5.0 & 5.8 EFI	—	18-1909-1	—	18-8507	—	18-0943-2
1993	5.8L (Ford)	—	18-1909-1	—	18-8507	18-0183-1	18-0943-2
1993	7.4L (GM), 8.2L (GM)	—	18-1909-1	—	18-8507	18-0418	18-0943-2
1993	351 King, 454/454 HO/502	—	—	—	—	—	18-0943-2
1992	5.0/5.0 HO/5.8 Liter	—	18-1909-1	—	18-8507	18-0183-1	18-0943-2
1992	5.8L (Ford)	—	—	—	—	18-0183-1	18-0943-2
1992	7.4L (GM), 8.2L (GM)	—	—	—	—	18-0418	18-0943-2
1992	351 King Cobra	—	—	—	—	18-0183-1	18-0943-2
1992	454/454 HO/502	—	—	—	—	—	18-0943-2
1991	4.3/4.3 HO	—	—	—	—	—	18-0943-2
1991	5.8L (Ford), 5.0/5.0HO/5.8 Liter	—	18-1909-1	—	18-8507	18-0183-1	18-0943-2

② 5.0L only

APPLICATION CONTINUED ON NEXT PAGE

MANIFOLD/MANIFOLD GASKET APPLICATION

Year	Horsepower	Exhaust Manifold	Exhaust Elbow	Manifold Mount Kit	Elbow Mount Kit	Manifold Gasket	Elbow Gasket
1991	454/454 HO	—	18-1909-1	—	18-8507	—	18-0943-2
1991	7.4L (GM)	—	18-1909-1	—	18-8507	18-0418	18-0943-2
1990-91	8.2L (GM)	—	18-1909-1	—	18-8507	—	—
1982-83,1985-90	3.0 Liter	18-1901	18-1922	—	—	—	18-2875-1
1990	4.3 Liter	—	18-1909-1	—	18-8507	—	—
1990	5.0/5.0 HO/5.8 Liter	—	18-1921	—	—	18-0183-1	18-0943-2
1990	5.0/5.7L	18-1986-1	18-1909-1	18-8502	18-8507	18-2902-1	18-0943-2
1990	7.4L (GM)	—	—	—	—	18-0418	18-0943-2
1990	7.5L (Ford)	—	—	—	—	18-0992	18-0943-2
1990	454 King Cobra	—	—	—	—	—	18-0943-2
1987-90	460 King Cobra	—	—	—	—	—	18-0943-2
1989	5.0/5.0 HO/5.8 Liter	—	18-1921	—	18-8534	18-0183-1	18-0943-2
1989	5.7/350 King Cobra	—	—	—	—	18-2902-1	18-0943-2
1988	5.0/5.7/350 King Cobra	18-1902 #	18-1921	18-8502	18-8534	18-2902-1	18-0943-2
1988	5.0/5.7/350 King Cobra	18-1903 *	18-1921	18-8502	18-8534	18-2902-1	18-0943-2
1988	370 King Cobra	—	—	—	—	—	18-0943-2
1982-87	5.0/5.7 Liter	18-1902 #	18-1921 ①	18-8502	18-8534	18-2902-1	18-0943-2
1982-87	5.0/5.7 Liter	18-1903 *	18-1921	18-8502	18-8534	18-2902-1	18-0943-2
1982-86	2.5 Liter	18-1901	18-1922	—	—	18-2896-1	18-2875-1
1984	3.0 Liter	18-1901	18-1921	—	18-8534	—	18-2875-1
1978-81	400 Series, 120 HP	—	—	—	—	18-2896-1	18-2861-1
1978-81	400 Series, 140 HP	—	18-1922	—	—	—	18-2875-1
1981	800 Series, 200,230,260 HP	18-1902 #	18-1921	18-8502	18-8534	18-2902-1	18-0943-2
1981	800 Series, 200,230,260 HP	18-1903 *	18-1921	18-8502	18-8534	18-2902-1	18-0943-2
1980	800 Series, 185-260 HP	18-1902 #	18-1921	18-8502	18-8534	18-2902-1	18-0943-2
1980	800 Series, 185-260 HP	18-1903 *	18-1921	18-8502	18-8534	18-2902-1	18-0943-2
1979	800 Series,185-230 HP	18-1902 #	18-1921	18-8502	18-8534	18-2902-1	18-0943-2
1979	800 Series,185-230 HP	18-1903 *	18-1921	18-8502	18-8534	18-2902-1	18-0943-2
1979	800 Series, 260 HP	18-1902 #	18-1921	18-8502	18-8534	18-2902-1	18-0943-2
1979	800 Series, 260 HP	18-1903 *	18-1921	18-8502	18-8534	18-2902-1	18-0943-2
1978	800 Series, 185-225 HP	18-1902 #	18-1921	18-8502	18-8534	18-2902-1	18-0943-2
1978	800 Series, 185-225 HP	18-1903 *	18-1921	18-8502	18-8534	18-2902-1	18-0943-2
1978	800 Series, 240 HP	—	18-1921	—	18-8534	—	—
1977	120 HP	—	—	—	—	18-2896-1	18-0943-2
1977	140 HP	—	18-1922	—	—	—	18-2861-1
1977	175 THRU 235 HP	—	18-1921	—	18-8534	18-0183-1	18-2875-1
1976	120 HP	18-1904	—	—	—	18-0183-1	18-0943-2
1974-76	140 HP	18-1904	18-1922	—	—	—	18-2861-1
1976	165 HP	18-1904	18-1922	—	—	18-2830-1	18-2875-1
1976	175 THRU 235 HP	18-1904	—	—	—	18-0183-1	18-2875-1
1974-75	120 HP	18-1904	—	—	—	18-2896-1	18-2850-1
1974-75	165 HP	18-1904	18-1922	—	—	—	18-2875-1
1975	175 THRU 235 HP	18-1904	—	—	—	18-0183-1	18-2875-1
1974	170 & 190 HP	18-1904	—	—	—	18-0183-1	18-2875-1
1974	175 THRU 235 HP	18-1904	—	—	—	18-0183-1	18-2850-1
1973	100,120,140 HP	—	—	—	—	18-2896-1	18-2861-1
1973	165 HP	—	18-1922	—	—	18-2896-1	18-2861-1
1972-73	225 & 245 HP	—	—	—	—	—	18-2883
1972	100,120 HP	—	—	—	—	18-2896-1	18-2861-1
1972	155 HP	—	—	—	—	N/A	18-2883
1972	165 HP S MODEL, C MODEL	—	—	—	—	—	18-2875-1
1971	215 & 235 HP	—	—	—	—	—	18-2859
1965-71	120 HP	—	—	—	—	—	18-2861-1
1967-71	155 HP	—	—	—	—	N/A	18-2859
1968-70	210 HP	—	—	—	—	—	18-2859
1967-68	185 HP	—	—	—	—	—	18-2859
1966-68	200 HP	—	—	—	—	N/A	18-2859
1964-66	150 HP	—	—	—	—	N/A	18-2859
1964	110 HP	—	—	—	—	N/A	18-2859

Starboard

* Port

① High rise applications only for 1985

② 5.0L only

OIL FILTERS



Display Package

Part #	Fits:	O.E.M #
18-7824-2	GM Engines (Short Filter)	173232, 502902
18-7875	Ford Engines (Long Filter)	173231, 502900
18-7876-1	GM Engines (Long Filter)	173233, 502901
18-7878-1	M-100, M200 (Short Filter)	502904
18-7879-1	GM V-6 Engines	173834, 502903

SEE PAGES 182-184 & 1147-1170 FOR ADDITIONAL INFORMATION

CYLINDER HEAD ASSEMBLIES

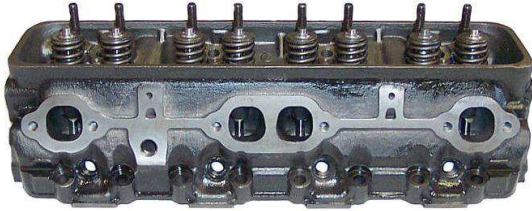

18-4485
CYLINDER HEAD ASSEMBLY

Fits: 5.7L V-8 GM (1987-95) with press in rocker arm studs with 12 intake manifold mounting bolts- (4 inside intake manifold bolts at 23 degrees), center mount valve covers



18-4486
CYLINDER HEAD ASSEMBLY

Fits: 5.7L V-8 GM Vortec (1996-Up) with press in rocker arm studs with 8 intake manifold mounting bolts, composite valve cover



18-4486HP
CYLINDER HEAD ASSEMBLY

Fits: Vortec GM small block 5.7L high performance
Completely assembled with revised runner and combustion chambers. Add 30hp to stock motor with no additional modifications.

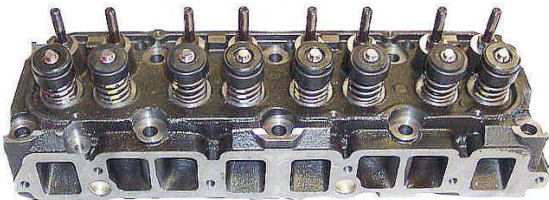

18-4489
CYLINDER HEAD ASSEMBLY

Fits: 2.5L/3.0L GM (1968-95)



18-4491
CYLINDER HEAD ASSEMBLY

Replaces 4.3L Vortec V-6 (1996-Up) with screw in rocker arm studs (non-adjustable valve train), 8 intake manifold mounting bolts, center mount valve cover. NOTE: not for use with engines using factory roller rocker arms.



18-4501
CYLINDER HEAD

Fits: 5.0L Vortec



18-4501HP
CYLINDER HEAD

Fits: Vortec GM small block 5.0L
Completely assembled with revised runner and combustion chambers. Add 30hp to stock motor with no additional modifications.





18-1400
HYDRAULIC LIFTER
 Replaces: 3856127
 GM 4.3L/V-6 Late/5.0L/5.7L



18-1401
HYDRAULIC LIFTER
 Replaces: 3853847, 985316
 Ford 5.0L & 5.8L



18-1402
HYDRAULIC LIFTER
 Replaces: 3854033, 502036
 GM 2.5L/120
 For: OMC & Volvo 3.0L/181 CID

**ALL PISTONS
 ARE SUPPLIED COMPLETE WITH PISTON RINGS AND WRIST PIN.**



RINGS		RINGS (Cont.)	
Std.	REPLACES OMC/VOLVO	Std.	REPLACES OMC/VOLVO
18-3937	*14089025	18-3938	328516
18-3937	328506	18-3938	914557
18-3937	3853960	PISTONS	
18-3937	914555	18-4161	3853340, 914816
18-3937	3853268	18-4173	*14077948
18-3937	985083, 986336	18-4173	3911020
18-3944	370409	0.02	
0.02		18-4160	3853477, 915236
18-3939	3854252	0.03	
18-3939	914556	18-4164	*14077949, 3911023
0.03		* OMC References GM Number	
18-3938	*14089026		

PISTON / RING APPLICATION							
Model	PISTONS			RINGS			Qty. per Eng.
	Std.	.020	.030	Std.	.020	.030	
OMC							
GM							
2.5L/153 CID	18-4180	18-4183	-	18-3942	-	-	4
3.0L/181 CID	18-4161	18-4160	18-4191	18-3937	18-3939	18-3938	4
I-6/250 CID	-	-	-	18-3942	-	-	6
4.3L/V-6	18-4173	18-4188	18-4164	18-3937	18-3939	18-3938	6
5.0L/305 CID	-	-	18-4178	18-3944	-	-	8
5.7L/350 CID	18-4173	18-4188	18-4164	18-3937	18-3939	18-3938	8
7.4L/454 CID	18-4171	18-4189	18-4172	18-3940	-	-	8
FORD							
5.0L/302 CID	-	-	-	18-3937	18-3939	18-3938	8

 <p>ROD BEARINGS</p>		 <p>MAIN BEARINGS</p>			 <p>CAM BEARINGS</p>	
Part #	Size	Part #	Per Eng.	Size	Part #	Per Eng.
18-1308	Std.	18-1300	②	Std.	18-1339	1 ②
18-1309	.010	18-1311	②	Std.	② Complete engine set	
18-1327	Std.	18-1316	②	.010		
18-1329	Std.	18-1317	②	Std.		
18-1333	.010					
18-1334	Std.					
18-1337	.010					
18-1341	.020					
Rod bearings sold individually, 1 per rod						

BEARING APPLICATION

Model	ROD BEARING			MAIN BEARING			CAM BEARING
	Std.	.010	.020	Std.	.010	.020	
OMC							
GM							
2.5L/153 CID	18-1329	18-1330	-	18-1317	18-1316	-	18-1339
3.0L/181 CID	18-1308	18-1309	18-1341	18-1317	18-1316	-	18-1339
I-6/230 CID	18-1329	18-1330	-	-	-	-	-
I-6/250 CID	18-1308	18-1309	18-1341	-	-	-	-
4.3L/V-6	18-1327	18-1337	-	18-1311	-	-	-
5.0L/305 CID	18-1308	18-1309	18-1341	18-1300	-	-	-
5.7L/350 CID	18-1308	18-1309	18-1341	18-1300	-	-	-
7.4L/454 CID	18-1334	18-1333	18-1332	-	-	-	-
FORD							
5.0L/302 CID	—	-	-	-	-	-	-

 <p>One Piece Rear Main Seals</p> <p>18-1234 Replaces: 3853528</p> <p>18-0519 Replaces 3852657, 912957</p>	 <p>Two Piece Rear Main Seals</p> <p>18-0528 Replaces: 913745</p> <p>18-1211 Replaces: 473424</p>	 <p>Timing Cover Seals</p> <p>18-1213 Replaces: 3853341 912989, 914817</p> <p>18-1230 Replaces: 3853827, 984884</p> <p>18-1233 Replaces: 3860095</p>
--	---	---

OMC SEAL APPLICATION

Engine Model	2 Piece Rear Main Crankshaft Seal Conv. Rotation (LH)	Timing Cover Seal
GM		
2.5L/153 CID	18-1211 ②	18-1213
3.0L/181 CID	18-1211 ②	18-1213
I-6/230CID	18-1211 ②	18-1213
I-6/250CID	18-1211 ②	18-1213
4.3L/V-6	18-1211 ②	18-1213
5.0L/305 CID	18-1211 ①	18-1213
5.7L/350 CID	18-1211 ①	18-1213
7.4L/454 CID	③	18-1233
FORD		
5.0L/302 CID	18-0528	
5.8L/351 CID	—	18-1230

① Large Journal Crankshaft GM Engines ② For One Piece Seal (LH) Models Use 18-0519 ③ For One Piece Seal (LH) Models Use 18-1234

FOR MODULAR GASKET SETS SEE PAGES 653-660

MISCELLANEOUS GASKETS/GASKET SETS

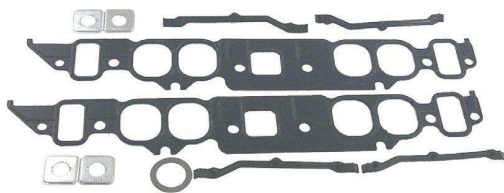

18-0465
INTAKE MANIFOLD GASKET SET
 Replaces: 352670
 For: GM 454 CID Engines, 325, 330, 340, 350 HP
 and 454 Magnums, 7.4L

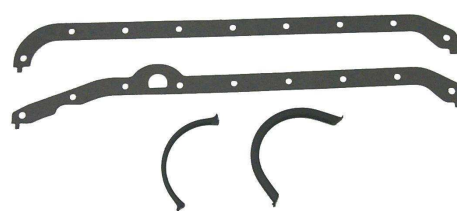

18-0153
OIL PAN GASKET SET
 Replaces:
 393159, 458625, 357159
 For: OMC 5.7L



18-1239
OIL PAN GASKET
 Replaces: 914820
 For: OMC 3.0L



18-0348
OIL PAN GASKET SET
 Replaces: 3931593, 508871



18-1237
OIL PAN GASKET
 Replaces: 3856138
 For: GM 5.7L



18-0466
OIL PAN GASKET SET
 Replaces: 393061, 3923440, 3921473

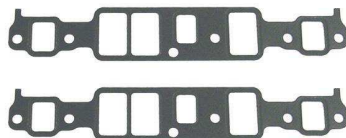

18-1238
INTAKE GASKET SET
 Replaces: 3850379, 912979
 For: OMC 4.3L 1993-96



18-1231
INTAKE GASKET
 Replaces: 3854095



18-0405
OIL PAN GASKET
 Replaces:
 3852655, 912955
 For: OMC 4.3L



18-0407
OIL PAN GASKET SET
 Replaces: 508872



18-0410
INTAKE MANIFOLD GASKET SET
 Replaces:
 988162, 3854406, 986103,
 3853912, 986104, 3853913
 For: OMC 5.0L & 5.8L (1989-96)



18-0411
OIL PAN GASKET SET
 Replaces:
 458625, 357159, 508876



18-1232
OIL PAN GASKET
 Replaces: 3853510



18-0868
INTAKE MANIFOLD GASKET SET
 Replaces:
 985630, 3854269
 For: OMC 5.7L 1994, 1996-97

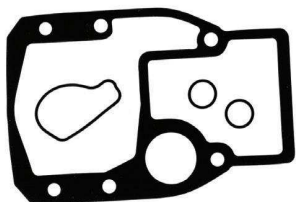

Display Package

18-2613
OUTDRIVE GASKET SET
 Replaces: 508105

— CONTAINS —

Part #	Description	O.E. #	Qty.
18-2918	Outdrive Gasket	911836	1
18-2996	Outdrive Seal	911823	1
18-7153	O-Ring	911851	2

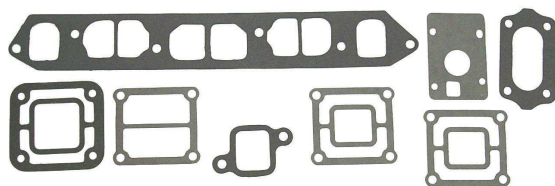

18-4369
EXHAUST MANIFOLD GASKET SET
 For: 2.5L (1985-86) and 3.0L (1985-88)

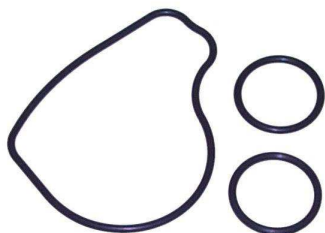

18-2699
OUTDRIVE GASKET
 For: SX Drives
 Use 18-3721 Mounting Nuts

— CONTAINS —

Part #	Description	O.E. #	Qty.
18-7153	O-Ring	911851	2
18-2996	Outdrive Seal	911823	1

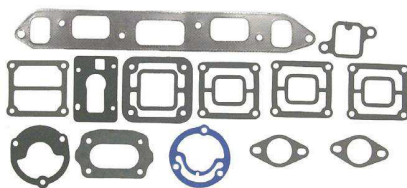

18-4370
EXHAUST MANIFOLD GASKET SET
 For: 100, 120 HP and 2.5L (1965-85)

— CONTAINS —

Part #	Description	O.E. #	Qty.
18-0114-1	Manifold End Cap Gasket	907761	1
18-2896-1	Exhaust Manifold Mounting Gasket	311068	1
18-0104	Exhaust Elbow Gasket	907764	1
18-0164	Thermostat Housing Gasket	311069	1
18-0937	Carb. Mtg. Gasket	315055	1
18-2861-1	Manifold End Cap Gasket	311121	3
18-2875-1	Elbow To Manifold Gasket	908013	1
18-2858	Thermostat Cover Housing Gasket	314809	1

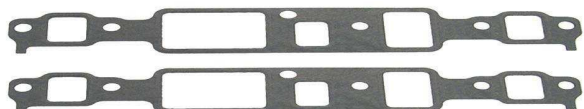

18-4408
INTAKE MANIFOLD GASKET SET
 Replaces: 912978
 For: GM 4.3L

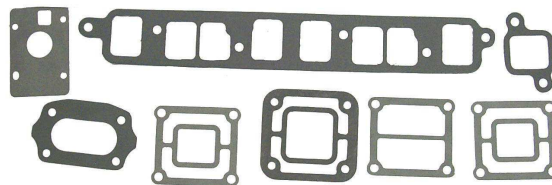

18-4371
EXHAUST MANIFOLD GASKET SET
 For: 140 HP and 3.0L (1973-84)

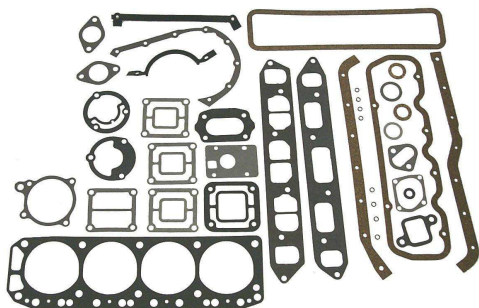

18-4373
OVERHAUL GASKET SET
 For: 110, 120 HP and 2.5L (1965-86)

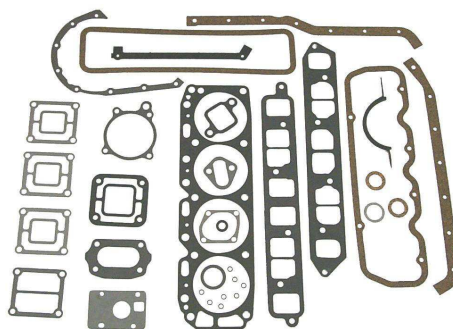









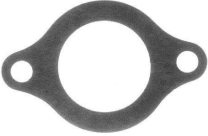
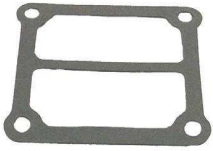
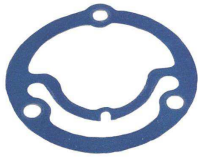



18-4374
OVERHAUL GASKET SET
 For: 140 HP and 3.0L (1973-88)

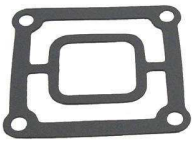









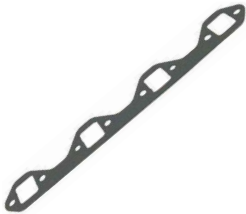

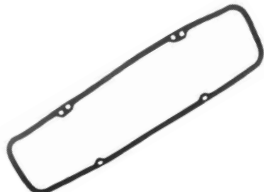

 <p>18-2946 HEAD GASKET Replaces: 3853336, 908611 For: GM 181 (3.0L) CID Eng.</p>	 <p>18-3874 HEAD GASKET Replaces: 3853511 For: (8.2L) 502 CID</p>	 <p>18-3876 HEAD GASKET Replaces: 3853380, 914971 For: GM 305 (5.0L)/350 (5.7L) CID Eng.</p>	 <p>18-3877 HEAD GASKET Replaces: 914849 For: GM 454 (7.4L) CID Eng.</p>
 <p>18-3878 HEAD GASKET Replaces: 912766 For: 460 Ford</p>	 <p>18-3879 HEAD GASKET Replaces: 3854299, 912227, 914930 For: GM 262 (4.3L) CID Eng.</p>	 <p>18-3880 HEAD GASKET Replaces: 311210 For: GM 153 (2.5L)</p>	 <p>18-3881 HEAD GASKET Replaces: 908237 For: GM 250 (4.1L) CID (6 cyl) Eng.</p>
 <p>18-3883 HEAD GASKET Replaces: 3853732 For: Ford 302 (5.0L) 351 (5.8L) CID Eng.</p>	 <p>18-3887 HEAD GASKET Replaces: 915325 For: (7.4L) 454 CID GEN V</p>	 <p>18-0434 CARB MOUNTING GASKET Replaces: 909758</p>	<p>PKG. of 2</p>  <p>18-5399 18-5399-9① DISTRIBUTOR CAP GASKET Replaces: 910169</p>
<p>PKG. OF 2</p>  <p>18-0874 18-0874-9① DISTRIBUTOR GASKET For GM V6 & V8 Replaces: 3852109, 312780 For: 2.6L (1989), 3.5L (1989), 4.3L (1987-93), 5.0L (1987-88), 5.7L (1987-92), 7.4L (1988-93), 8.2L (1992-93)</p>	<p>PKG. OF 2</p>  <p>18-0937 18-0937-9① CARB MOUNTING GASKET Replaces: 315055</p>	<p>PKG. OF 2</p>  <p>18-0435 CARB MOUNTING GASKET Replaces: 908765</p>	<p>PKG. OF 2</p>  <p>18-0876 18-0876-9① FUEL PUMP GASKET For GM 4.3L, 5.0L & 5.7L Replaces: 3852113, 312800</p>
<p>PKG. OF 2</p>  <p>18-0164 18-0164-9① THERMOSTAT GASKET 4 & 6 Cyl. Replaces: 311069 GM 3789161</p>	<p>PKG. OF 2</p>  <p>18-0929 18-0929-9① THERMOSTAT GASKET Replaces: 313416</p>	<p>PKG. OF 2</p>  <p>18-2858 18-2858-9① THERMOSTAT GASKET Replaces: 314809</p>	<p>PKG. OF 2</p>  <p>18-2917 18-2917-9① THERMOSTAT GASKET Replaces: 312797, 3701777 (GM)</p>

SEE PAGES 201-202 FOR OUR COMPLETE LINE OF GASKET SEALANTS





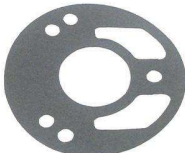









① Priced per Package

<p>PKG. OF 2</p>  <p>18-2947 18-2947-9① THERMOSTAT GASKET Replaces: 310913</p>	<p>PKG. OF 2</p>  <p>18-0398 18-0398-9① THERMOSTAT GASKET Replaces: 312797, 3852111</p>	 <p>18-0114-1 MANIFOLD END GASKET Replaces: 907761 For GM 4 Cyl.</p>	<p>PKG. OF 2</p>  <p>18-0104 18-0104-9① EXHAUST ELBOW GASKET Replaces: 907764</p>
 <p>18-0430 EXHAUST ELBOW GASKET Replaces: 912477</p>	<p>PKG. OF 2</p>  <p>18-0673 18-0673-9① EXHAUST ELBOW GASKET Replaces: 910113</p>	<p>PKG. OF 2</p>  <p>18-0943-2 18-0943-2-9① EXHAUST ELBOW GASKET Replaces: 913783, 909786, 3850496</p>	<p>PKG. OF 2</p>  <p>18-2850-1 18-2850-9① MANIFOLD END CAP GASKET Replaces: 908935</p>
<p>PKG. OF 2</p>  <p>18-2859 18-2859-9① MANIFOLD END CAP GASKET Replaces: 311131</p>	<p>PKG. OF 2</p>  <p>18-2860 18-2860-9① MANIFOLD END CAP GASKET Replaces: 311130</p>	<p>PKG. OF 2</p>  <p>18-2861-1 18-2861-9① MANIFOLD END CAP GASKET Replaces: 311121</p>	<p>PKG. OF 2</p>  <p>18-2875-1 18-2875-1-9① EXHAUST ELBOW GASKET Replaces: 908013, 3850495</p>
<p>PKG. OF 2</p>  <p>18-2883-1 18-2883-1-9① MANIFOLD END CAP GASKET Replaces: 907775</p>	 <p>18-2541 RUBBER SEAL Replaces: 911704</p>	 <p>18-0401 EXHAUST MANIFOLD GASKET Replaces: 913393 For Ford 140 CID (2.3L)</p>	 <p>18-0431 INTAKE MANIFOLD GASKET Replaces: 912471 For Ford 140 CID (2.3L)</p>
 <p>18-0956-1 EXHAUST MANIFOLD GASKET Replaces: 912405 460 CID</p>	 <p>18-2912-1 EXHAUST MANIFOLD GASKET Replaces: 908079</p>	 <p>18-2830-1 EXHAUST MANIFOLD GASKET Inline 6 cyl. Replaces: 907932</p>	 <p>18-2896-1 EXHAUST MANIFOLD GASKET Replaces: 311068</p>

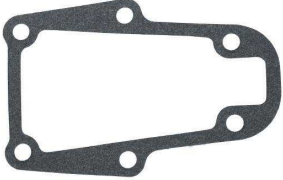















① Priced per Package

<p>PKG. OF 2</p>  <p>18-2909 18-2909-9① EXHAUST MANIFOLD GASKET Replaces: 915025 GM V-6</p>	 <p>18-0183-1 EXHAUST MANIFOLD GASKET Replaces: 3853742, 3852455, 908717, 916262 For: OMC 5.0L & 5.8L (1993-96)</p>	 <p>18-0680 EXHAUST MANIFOLD GASKET Replaces: 3853256</p>	 <p>18-0418 EXHAUST MANIFOLD GASKET Replaces: 909613</p>
<p>PKG. OF 2</p>  <p>18-1204-1 18-1204-1-9① EXHAUST MANIFOLD GASKET Replaces: 912164</p>	 <p>18-0892 DEFLECTOR HOSE Replaces: 322411</p>	 <p>18-0664 VALVE COVER GASKET Replaces: 913270, 3852687 For: GM 305/350, 5.0 & 5.7L</p>	 <p>18-2845 VALVE COVER GASKET Replaces: 912965 For GM 305/350 CID (5.0L and 5.7L)</p>
 <p>18-0311 VALVE COVER GASKET Replaces: 3854942 For: 4.3 Litre 262 CID</p>	 <p>18-0346 VALVE COVER GASKET Replaces: 3930912 For: GM 250 CID (4.1L), 160/165/200 (6 cyl.)</p>	 <p>18-0347 VALVE COVER GASKET Replaces: 3852693, 912981, 913277 For: GM 153 & 181 CID (2.5L & 3.0L)</p>	<p>PKG. OF 2</p>  <p>18-0464 18-0464-9① VALVE COVER GASKET Replaces: 912768 For: GM 454/502 CID (7.4L & 8.2L)</p>
 <p>18-0352 VALVE COVER GASKET Replaces: 913758 For: Ford 302/351 CID (5.0L & 5.8L)</p>	 <p>18-0548 ADAPTER TO INTERMEDIATE HOUSING GASKET Replaces: 909515</p>	<p>PKG. OF 2</p>  <p>18-0947 18-0947-9① PIVOT CAP COVER GASKET Replaces: 909529</p>	<p>PKG. OF 2</p>  <p>18-0440 18-0440-9① WATER PASSAGE COVER GASKET Replaces: 915719</p>
 <p>18-0911 WATER PUMP GASKET Replaces: 911698</p>	<p>PKG. OF 2</p>  <p>18-0903 18-0903-9① WATER PUMP GASKET Replaces: 3853361 454 CID</p>	 <p>18-0147 WATER PUMP GASKET For Ford V-8 Replaces: 3852824</p>	 <p>18-0327 WATER PUMP GASKET Replaces: 3853342 4 & 6 Cyl.</p>

① Priced per Package

<p>PKG. OF 2</p>  <p>18-2916 18-2916-9^① WATER PUMP HOUSING GASKET Replaces: 911702</p>	 <p>18-0939 18-0939-9^① UPPER GEARCASE DIPSTICK GASKET Replaces: 315189</p>	 <p>18-0468 TIMING COVER GASKET Replaces: 3853512, 912954, 3852654, 915326 For: OMC 2.6L, 3.5L (1989), 4.3L (1987-93), 5.0L (1987-88), 5.7L (1987-92, 1994, 1996)</p>	<p>PKG. OF 2</p>  <p>18-0891 18-0891-9^① WATER PUMP MOUNTING GASKET Replaces: 3852477, 909835 For: GM 4.3L, 5.0L & 5.8L</p>
<p>PKG. OF 2</p>  <p>18-0893 18-0893-9^① WATER PUMP BACK-IN PLATE GASKET Replaces: 3850595 GM 4.3L, 5.0L & 5.7L</p>	<p>PKG. OF 2</p>  <p>18-0322 18-0322-9^① REAR SEAL GASKET Replaces: 3852656 GM 5.0L & 5.7L</p>	 <p>18-0329 PUSH ROD/LIFTER COVER GASKET</p>	<p>PKG. OF 2</p>  <p>18-0887 18-0887-9^① TIMING COVER GASKET Replaces: 3852691, 912988, 913275 4 & 6 Cyl.</p>
 <p>18-0980 TIMING COVER GASKET Replaces: 3935449 GM 7.4L</p>	<p>PKG. OF 2</p>  <p>18-0880 18-0880-9^① SHIFT COVER GASKET Replaces: 911878</p>	<p>PKG. OF 2</p>  <p>18-0166 18-0166-9^① GROMMET Replaces: 911705</p>	 <p>18-2815 PUSH ROD COVER GASKET Replaces: 3852692, 913276 For: 3.0L</p>
 <p>18-0190 WIPER GASKET Replaces: 912157</p>	<p>PKG. OF 2</p>  <p>18-2851 18-2851-9^① SWIVEL BEARING GASKET Replaces: 313368</p>	<p>PKG. OF 2</p>  <p>18-2863 18-2863-9^① TILT CLUTCH COVER GASKET Replaces: 308799</p>	<p>PKG. OF 2</p>  <p>18-2911 18-2911-9^① SWIVEL BEARING HOUSING GASKET Replaces: 910236</p>

① Priced per Package

<p>PKG. OF 5</p>  <p>18-2918 18-2918-9^① OUTDRIVE GASKET Replaces: 911836, 915840</p>	<p>PKG. OF 5</p>  <p>18-2996 18-2996-9^① OUTDRIVE SEAL Replaces: 911823, 3852560</p>	<p>PKG. OF 2</p>  <p>18-0923 18-0923-9^① RUBBER SEAL Replaces: 313244</p>	<p>PKG. OF 2</p>  <p>18-0188 18-0188-9^① WASHER Replaces: 909748</p>
 <p>18-1704 SCREW Replaces: 331980 For: Waterpumps, power packs (1985-96)</p>	 <p>18-1236 DRAIN SCREW Replaces: 309243 For Cobra Drives & V-6 40-50HP (1989-97)</p>  <p>18-2387 18-23871-9^① (PKG. OF 50) LOWER UNIT DRAIN SCREW Replaces: 307551 Fits: OMC V-6, V-4(1979 & Up), 60-75hp 3 cylinder, 20-35hp (1985-97)</p>	 <p>18-2378 18-23781-9^① (PKG. OF 50 without washer) MAGNETIC DRAIN SCREW Replaces: 318544 Fits: Cobra 2.3, 3.0, 3.8 & 5.8L (1986-92), V-6, V-4(1979 & Up), 60-75hp 3 cyl, 40/50hp (1989-98)</p>	<p>PKG. OF 5</p>  <p>18-4253-9^① 18-42531-9^① (PKG. OF 50) DRAIN SCREW O-RING Replaces: 336982 Used w/ 18-1236 Drain Screw</p>
<p>PKG. OF 2</p>  <p>18-2945 18-2945-9^① DRAIN SCREW GASKET Replaces: 307552</p>	 <p>18-8369 OIL INDICATOR WITH WASHER Replaces: 914488 Uses o-ring 18-7116 Fits: OMC Cobra (1986-93) without cone clutch</p>	<p>PKG. OF 5</p>  <p>18-4248 18-4248-9^① 18-42481-9^① (PKG. OF 50) DRAIN/FILL PLUG WASHER (Plastic) Replaces: 311598</p>	<p>PKG. OF 5</p>  <p>18-4250 18-4250-9^① WASHER Replaces: 911820</p>
 <p>18-0549 PLUG OFF CAP Replaces: 909829 I.D. 1" For V-8 Model Stern Drives and Inboards (1977 to present)</p>	 <p>18-0550 PLUG OFF CAP Replaces: 909830 I.D. 1 1/4" For V-8 Model Stern Drives and Inboards 1977 to present</p>	 <p>18-0518 VALVE STEM SEAL Replaces: 3854956, 914323, 3853132 For: most inline 4 and 6 cyl. GM (Early) and 305-350 CID GM</p>	<p>PKG. OF 8</p>  <p>18-4024 18-4024-9^① VALVE STEM SEAL Replaces: 3853226, 914445 For: Chevy 4.3L/5.0L/5.7L</p>

① Priced per Package

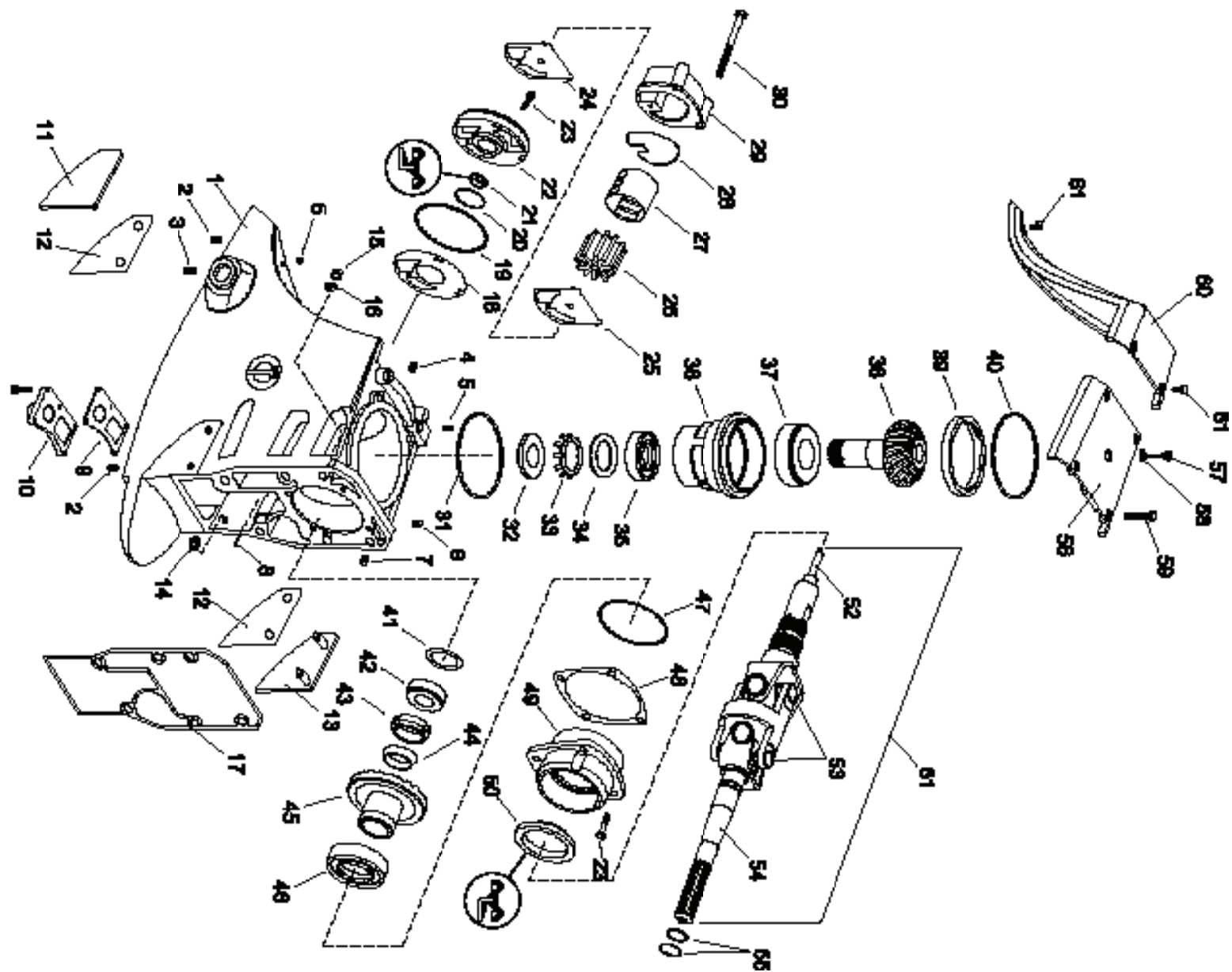

Figure #	Description	Part #	O.E.M. #	Qty.	Figure #	Description	Part #	O.E.M. #	Qty.
1	Upper Gear Housing, Basic w/ Inserts	~	984518	1	32	Pinion Nut	18-3769	911753	1
2	Gearcase Insert	NSS	910935	5	33	Nut Retainer	18-3610	911752	1
3	Gearcase Insert	NSS	911779, 3852541	5	34	Pinion Washer	NSS	911697	1
4	Gearcase Insert	NSS	910901	5	35	Pinion Bearing, Lower	18-1170	983892	1
5	Gearcase Insert	NSS	911858, 3852567	3	36	Bearing Carrier, Pinion	18-4828	911750	1
6	Gearcase Insert	NSS	910901	4	37	Pinion Bearing, Upper	18-1161	983891	1
7	Gearcase Insert	NSS	910901	4	38	Gear Set, 21:16 (includes 38 & 45)	18-1600	983825	AR
8	Shift Rod Guide	NSS	912137	1	38	Gear Set, 21:18 (includes 38 & 45)	18-1601	983826	AR
9	Gasket, Water Passage Cover	18-0884	911733	1	38	Gear Set, 21:19 (includes 38 & 45)	18-1602	984012	AR
10	Water Passage Cover	18-4837	911734	1	39	Retainer Ring, Pinion Housing	18-3768	911751	1
11	Thrust Plate, Starboard	NSS	911838, 3852562	1	40	O-Ring, Gear Housing Cover	18-7107	313175	1
12	Shim, Thrust Plate, 0.015"	18-1713	911839, 3852563	AR	41	Shim, Gear Position, 0.003"	18-02062	911662	AR
13	Thrust Plate, Port	NSS	911837, 3852561	1	41	Shim, Gear Position, 0.005"	18-02063	911663	AR
14	Retainer Ring, Thrust Plate	NSS	910953	4	41	Shim, Gear Position, 0.007"	NSS	911664	AR
15	Nut	18-3730	912920, 3852648	6	41	Shim, Gear Position, 0.010"	18-02065	911665	AR
16	Washer	NSS	911833	6	41	Shim, Gear Position, 0.012"	18-02066	911666	AR
17	Gasket, Outdrive Mounting	18-2918	911836, 915840	1	41	Shim, Gear Position, 0.015"	18-02067	911667	AR
18	Gasket, Adapter to Gear Housing	18-0911	911698	1	42	Bearing, U-Joint Shaft	18-1171	983878	1
19	O-Ring, Adapter, Large	18-7407	911700	1	43	Nut, Gear to U-Joint	18-3770	911937	1
20	O-Ring, Adapter, Small	18-7403	909316	1	44	Centering Cone	18-4835	912029	1
21	Water Pump Shaft Seal	18-2068	911701, 915702, 916058, 3853655	1	45	Gear Set, 21:16 (includes 38 & 45)	18-1600	983825	AR
22	Adapter, Water Pump to Gear Housing	18-4836	911699	1	45	Gear Set, 21:18 (includes 38 & 45)	18-1601	983826	AR
23	Screw	18-1598	908668, 341013	6	45	Gear Set, 21:19 (includes 38 & 45)	18-1602	984012	AR
24	Gasket, Plate to Adapter	18-2916	911702	1	46	Bearing, Bearing Carrier	18-1172	983877	1
25	Plate, Water Pump	18-3121	911703	1	47	O-Ring, Bearing Carrier	18-7169	911686	1
26	Impeller	18-3058	983895, 777128	1	48	Shim, Bearing Carrier, 0.003", Green	18-0227	911678	AR
27	Liner, Water Pump Cover	18-3145	911844	1	48	Shim, Bearing Carrier, 0.004", Tan	18-0229	911679	AR
28	Seal, Water Pump Housing	18-2541	911704	1	48	Shim, Bearing Carrier, 0.005", Blue	18-02060	911680	AR
29	Impeller Housing	18-3206	984744	1	48	Shim, Bearing Carrier, 0.010", Brown	18-02061	911681	AR
30	Screw	NSS	912238	3	49	Gear Bearing Carrier	18-4838	911683	1
31	Shim, Bearing Carrier 0.010	18-0207	911668	AR	50	Seal, Bearing Carrier	18-2067	911685	1
31	Shim, Bearing Carrier 0.001	18-0209	911669, 911670, 611671, 911672, 911673, 911674, 911675, 911676, 911677	AR	51	U-Joint & Water Pump Shaft Assy	18-2338	983880	1
31	Shim, Bearing Carrier 0.003	18-0211	911669, 911670, 611671, 911672, 911673, 911674, 911675, 911676, 911677	AR	52	Stub & Water Pump Shaft	18-6399	984264	1
					53	U-Joint Assy	18-2104	912214	2
					54	Yoke Shaft	18-2146	912212	1
					55	O-Ring, U-Joint Shaft	18-7153	911851, 3852565	2
					56	Gear Housing Cover	18-4838	911845, 986363	1
					57	Oil Indicator	18-8369	914488	1
					58	O-Ring, Oil Indicator	18-7116	303067	1
					59	Screw, Gear Housing Cover	18-1599	123018	4
					60	Cover, Water Pump Access	18-4750	983967	1
					61	Screw, Water Pump Access Cover	18-4749-9	911859, 3852568	3
						Water Pump Repair Kit w/housing	18-3348	984461, 984744	1

AR As required

NSS Not Sold Separate



GEAR HOUSINGS

Part No.	OE No.	Description	Application
18-4804	984770, 986381	Upper Gear Housing Complete, 21: 16 Ratio	5.7L(1986-93), 5.8L(1986-89, 1991-93)
18-4805	984771, 986382	Upper Gear Housing Complete, 21: 18 Ratio	2.5L (1986-89), 3.0L(1986-93), 5.0L(1989-93)
18-4806	984765, 986380	Upper Gear Housing Complete, 21: 19 Ratio	4.3L, 3.0L high altitude OMC Cobra (1986-93)



SCREWS

Part No.	OE No.	Application
18-1279	317624	20, 25, 35 HP (1976-86) 120, 140, 275, 300 HP (1985-86) Cobra Drives
18-1598	341013	Fits: OMC Cobra (1986-93) without cone clutch
18-1599	123018	Fits: OMC Cobra (1986-93) without cone clutch
18-3135	306643	Cobra Drives
18-4749-9 ^①	3852568	For Cover Assembly: (3 Pack) Fits: 2.3L (1987-90), 2.5L (1986), 2.6L (1989), 3.0L (1986-93), 4.3L (1986-93), 5.0L (1986-94), 5.7L (1986-92), 5.8L (1989-93), 7.4L (1988)

^① PKG of 3, priced per package



**18-4801
COMPLETE LOWER UNIT ASSEMBLY**
Replaces: 5000356
Fits: 85-140hp Crossflow (1978-94) w/o Upper Driveshaft
Primered only

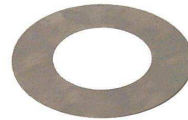

SHIMS

Part No.	O.E. No.	Size	Part No.	O.E. No.	Size
18-0207 ^①	911668	0.010	18-02065 ^①	911665	0.010
18-0209 ^①	911669, 911670, 911671, 911672, 911673, 911674, 911675, 911676, 911677	0.001	18-02066 ^①	911666	0.012
18-0211 ^①	911669, 911670, 911671, 911672, 911673, 911674, 911675, 911676, 911678	0.003	18-02067 ^①	911667	0.015
18-0227 ^{① ②}	911678	0.003	18-2229	323362	0.003
18-0229 ^{① ③}	911679	0.004	18-2230	323361	0.004
18-1713 ^①	3852563	0.015	18-2231	314745	0.005
18-1718 ^⑥	-	Kit			
18-02060 ^{① ④}	911680	0.005			
18-02061 ^{① ⑤}	911681	0.010			
18-02062 ^①	911662	0.003			
18-02063 ^①	911663	0.005			

^① Fits: OMC Cobra (1986-93) without cone clutch
^② Green
^③ Tan
^④ Blue
^⑤ Brown
^⑥ Kit includes 1 each of 18-2229, 18-2230 & 18-2231

NOTE: For shim sizes larger than .010" use shim 18-0207 and appropriate combination of .001" shim (18-0209), and .003" shim (18-0211) to reach desired shim thickness.



**18-9876
SHIM GAUGE TOOL**
Replaces: 349957

**MARINE GRADE 316 STAINLESS STEEL
WORM GEAR HOSE CLAMPS**

All components are manufactured from Marine Grade 316 stainless steel.
 These clamps are designed to fit many applications from 5/16" to 7" diameter hoses.



STAINLESS STEEL CLAMPS

Part #	Diameter Size	Std. #	Part #	Diameter Size	Std. #
18-710-06-2	5/16" to 7/8"	006	118-710-32-2	1 9/16" to 2 1/2"	032
118-710-10-2	9/16" to 1 1/16"	010	118-710-48-2	2 9/16" to 3 1/2"	048
18-710-12-2	9/16" to 1 1/4"	012	18-710-64-2	2 1/2" to 4 1/2"	064
18-710-16-2	1 1/16" to 1 1/2"	016	18-710-72-2	3" to 5"	072
118-710-20-2	3/4" to 1 3/4"	020	118-710-104-2	5" to 7"	104
118-710-24-2	1 1/16" to 2"	024			



**18-4442
ENGINE ALIGNMENT TOOL**
Used to verify engine alignment on Cobra models.



**18-2100
LINK BELT HEAVY DUTY GIMBAL BEARING**
Replaces: 983937
Uses seal 18-8349
Fits all OMC Cobra and King Cobra Drives



**18-3763
SHIFT SHAFT**
Replaces: 322941
For: V-4/V-6, Cobra, Stringer



18-2337
STUB SHAFT
Replaces: 3850814
Fits: All Cobra 1994-Up except King Cobra



18-6399
SHAFT & STUB ASSEMBLY
Replaces: 984264
For: Cobra Drives- 232, 302(1986-90), 252(1986), 262, 350, 460(1989), 432, 434, 502(1986-92), 504(1986-88), 574(1986-92), 584(1989-93), 754(1987-88)



18-2104
U-JOINT
Heavy Duty
Replaces: 912214, 915716
Fits OMC Cobra Drives (1986-89) Includes straight grease fitting and 90° fitting



18-2174
U-JOINT
Heavy Duty
Replaces: 915717, 3850812
Fits OMC Cobra and King Cobra Drives (1990 & ABOVE)
Includes straight grease fitting and 90° fitting.



18-2338
U-JOINT
Replaces: 983880
For: 1986-93 OMC Cobra



18-2339
U-JOINT ASSEMBLY
Replaces: 3852384
Fits: All Cobra 1994-Up except King Cobra



18-2146
UNIVERSAL YOKE ASSEMBLY
Replaces: 912212, 3850815
For: All Cobra (1986-Up)



18-3770
U-JOINT NUT
Replaces: 911937
For: 232, 252, 262, 302, 350, 432, 434, 460, 502, 504, 574, 584, 744, 754, (1987-93)

Model	Year	U-Joint #	U-Joint Assy. OE #	Long Yoke #	Long Yoke OE #	Short Yoke #	Short Yoke OE #
2.3L	1986 ①	18-2338	983880	18-2146	812212	18-6399	984264
3.0L	1986 ①	18-2338	983880	18-2146	812212	18-6399	984264
4.3L	1986 ①	18-2338	983880	18-2146	812212	18-6399	984264
5.7L	1986 ①	18-2338	983880	18-2146	812212	18-6399	984264
2.3L	1987-1988 ①	18-2338	983880	18-2146	912212	18-6399	984264
3.0L	1987-1988 ①	18-2338	983880	18-2146	912212	18-6399	984264
4.3L	1987-1988 ①	18-2338	983880	18-2146	912212	18-6399	984264
5.0L	1987-1988 ①	18-2338	983880	18-2146	912212	18-6399	984264
5.7L	1987-1988 ①	18-2338	983880	18-2146	912212	18-6399	984264
7.5L	1987-1988 ①	18-2338	983880	18-2146	912212	18-6399	984264
2.3L	1989 ①	18-2338	983880	18-2146	912212	18-6399	984264
3.0L	1989 ①	18-2338	983880	18-2146	912212	18-6399	984264
4.3L	1989 ①	18-2338	983880	18-2146	912212	18-6399	984264
5.0L	1989 ①	18-2338	983880	18-2146	912212	18-6399	984264
5.7L	1989 ①	18-2338	983880	18-2146	912212	18-6399	984264
5.8L	1989 ①	18-2338	983880	18-2146	912212	18-6399	984264
7.5L	1989 ①	18-2338	983880	18-2146	912212	18-6399	984264
2.3L	1990 ②	18-2338	983880	18-2146	912212	18-6399	984264
3.0L	1990 ②	18-2338	983880	18-2146	912212	18-6399	984264
4.3L	1990 ②	18-2338	983880	18-2146	912212	18-6399	984264
5.0L	1990 ②	18-2338	983880	18-2146	912212	18-6399	984264
5.7L	1990 ②	18-2338	983880	18-2146	912212	18-6399	984264
5.8L	1990 ②	18-2338	983880	18-2146	912212	18-6399	984264

APPLICATION CONTINUED ON NEXT PAGE

① Used where raw w/p is located on outdrive ② Used where raw w/p is located on engine ③ Excludes Model 58FBDPMDA, used where raw w/p is located on engine
 ④ Used where raw w/p is located on engine, incl. Model 58FBDPMDA

Model	Year	U-Joint #	U-Joint Assy. OE #	Long Yoke #	Long Yoke OE #	Short Yoke #	Short Yoke OE #
5.7L	1990 ①	18-2338	983880	18-2146	912212	18-6399	984264
7.4L	1990 ①	18-2338	983880	18-2146	912212	18-6399	984264
7.5L	1990 ①	18-2338	983880	18-2146	912212	18-6399	984264
3.0L	1991 ①	18-2338	983880	18-2146	912212	18-6399	984264
4.3L	1991 ①	18-2338	983880	18-2146	912212	18-6399	984264
5.7L	1991 ①	18-2338	983880	18-2146	912212	18-6399	984264
5.8L	1991 ①	18-2338	983880	18-2146	912212	18-6399	984264
7.4L	1991 ②	N/A	986191	18-2146	912212	N/A	914646
3.0L	1992-1993 ①	18-2338	983880	18-2146	912212	18-6399	984264
3.2L	1992-1993 ①	18-2338	983880	18-2146	912212	18-6399	984264
4.3L	1992-1993 ①	18-2338	983880	18-2146	912212	18-6399	984264
5.0L	1992-1993 ①	18-2338	983880	18-2146	912212	18-6399	984264
5.7L	1992-1993 ①	18-2338	983880	18-2146	912212	18-6399	984264
5.8L	1992-1993 ①	18-2338	983880	18-2146	912212	18-6399	984264
3.0L	1992-1993 ②	N/A	986191	18-2146	912212	N/A	914646
3.2L	1992-1993 ②	N/A	986191	18-2146	912212	N/A	914646
4.3L	1992-1993 ②	N/A	986191	18-2146	912212	N/A	914646
5.0L	1992-1993 ②	N/A	986191	18-2146	912212	N/A	914646
5.7L	1992-1993 ②	N/A	986191	18-2146	912212	N/A	914646
5.8L	1992-1993 ②	N/A	986191	18-2146	912212	N/A	914646
7.4L	1992-1993 ②	N/A	986191	18-2146	912212	N/A	914646
8.2L	1992-1993 ②	N/A	986191	18-2146	912212	N/A	914646
3.0L	1994 ③	18-2339	3852384	18-2146	3850815	18-2337	3850814
4.3L	1994 ③	18-2339	3852384	18-2146	3850815	18-2337	3850814
5.0L	1994 ③	18-2339	3852384	18-2146	3850815	18-2337	3850814
5.7L	1994 ③	18-2339	3852384	18-2146	3850815	18-2337	3850814
5.8L	1994 ③	18-2339	3852384	18-2146	3850815	18-2337	3850814
5.8L	1994 ④	N/A	3853937	18-2146	3850815	N/A	3853563
7.4L	1994 ④	N/A	3853937	18-2146	3850815	N/A	3853563
3.0L	1995 ②	18-2339	3852384	18-2146	3850815	18-2337	3850814
4.3L	1995 ②	18-2339	3852384	18-2146	3850815	18-2337	3850814
5.0L	1995 ②	18-2339	3852384	18-2146	3850815	18-2337	3850814
5.8L	1995 ②	18-2339	3852384	18-2146	3850815	18-2337	3850814
7.4L	1995 ②	N/A	3853937	18-2146	3850815	N/A	3853563
3.0L	1996 ②	18-2339	3852384	18-2146	3850815	18-2337	3850814
4.3L	1996 ②	18-2339	3852384	18-2146	3850815	18-2337	3850814
5.0L	1996 ②	18-2339	3852384	18-2146	3850815	18-2337	3850814
5.7L	1996 ②	18-2339	3852384	18-2146	3850815	18-2337	3850814
5.8L	1996 ②	18-2339	3852384	18-2146	3850815	18-2337	3850814
7.4L	1996 ②	18-2339	3852384	18-2146	3850815	18-2337	3850814
3.0L	1997 ②	18-2339	3852384	18-2146	3850815	18-2337	3850814
4.3L	1997 ②	18-2339	3852384	18-2146	3850815	18-2337	3850814
5.7L	1997 ②	18-2339	3852384	18-2146	3850815	18-2337	3850814
7.4L	1997 ②	18-2339	3852384	18-2146	3850815	18-2337	3850814
3.0L	1998 ②	18-2339	3852384	18-2146	3850815	18-2337	1850814
4.3L	1998 ②	18-2339	3852384	18-2146	3850815	18-2337	1850814
5.0L	1998 ②	18-2339	3852384	18-2146	3850815	18-2337	1850814
5.7L	1998 ②	18-2339	3852384	18-2146	3850815	18-2337	1850814
7.4L	1998 ②	18-2339	3852384	18-2146	3850815	18-2337	1850814
8.2L	1998 ②	18-2339	3852384	18-2146	3850815	18-2337	1850814
43APHUB	1995	18-2339	3852384	18-2146	3850815	18-2337	3850814
43FAPNCA	1996	18-2339	3852384	18-2146	3820815	18-2337	3850814
43FBPBYC	1998	18-2339	3852384	18-2146	3820815	18-2337	3850814
43FBPLKD	1997	18-2339	3852384	18-2146	3820815	18-2337	3850814
43FBPNCS	1996	18-2339	3852384	18-2146	3820815	18-2337	3850814
50FBPBYC	1998	18-2339	3852384	18-2146	3820815	18-2337	3850814
50FACPMDA	1994	18-2339	3852384	18-2146	3820815	18-2337	3850814

APPLICATION CONTINUED ON NEXT PAGE

① Used where raw w/p is located on outdrive ② Used where raw w/p is located on engine ③ Excludes Model 58FBDPMDA, used where raw w/p is located on engine
 ④ Used where raw w/p is located on engine, incl. Model 58FBDPMDA

Model	Year	U-Joint #	U-Joint Assy. OE #	Long Yoke #	Long Yoke OE #	Short Yoke #	Short Yoke OE #
50FACPMMDM	1994	18-2339	3852384	18-2146	3820815	18-2337	3850814
50FAGPMDA	1994	18-2339	3852384	18-2146	3820815	18-2337	3850814
50FAGPMMDM	1994	18-2339	3852384	18-2146	3820815	18-2337	3850814
50FAPHUB	1995	18-2339	3852384	18-2146	3850815	18-2337	3850814
50FAPHUE	1995	18-2339	3852384	18-2146	3850815	18-2337	3850814
50FAPNCA	1996	18-2339	3852384	18-2146	3820815	18-2337	3850814
50FAPNCS	1996	18-2339	3852384	18-2146	3820815	18-2337	3850814
50FBPBYC	1998	18-2339	3852384	18-2146	3820815	18-2337	3850814
57FAPLKD	1997	18-2339	3852384	18-2146	3850815	18-2337	3850814
57FAPNCA	1996	18-2339	3852384	18-2146	3850815	18-2337	3850814
57FAPNCS	1996	18-2339	3852384	18-2146	3850815	18-2337	3850814
57FCPBYC	1998	18-2339	3852384	18-2146	3820815	18-2337	3850814
57FCPBYD	1998	18-2339	3852384	18-2146	3820815	18-2337	3850814
57FCPLKD	1997	18-2339	3852384	18-2146	3850815	18-2337	3850814
57FDPLKD	1997	18-2339	3852384	18-2146	3850815	18-2337	3850814
58FACPMDA	1994	18-2339	3852384	18-2146	3820815	18-2337	3850814
58FACPMMDM	1994	18-2339	3852384	18-2146	3820815	18-2337	3850814
58FAGPMDA	1994	18-2339	3852384	18-2146	3820815	18-2337	3850814
58FAGPMMDM	1994	18-2339	3852384	18-2146	3820815	18-2337	3850814
58FAPHUB	1995	18-2339	3852384	18-2146	3820815	18-2337	3850814
58FAPHUE	1995	18-2339	3852384	18-2146	3820815	18-2337	3850814
58FBDMDA	1994	18-2339	3852384	18-2146	3820815	18-2337	3850814
58FBPHUB	1995	18-2339	3852384	18-2146	3820815	18-2337	3850814
58FBPHUE	1995	18-2339	3852384	18-2146	3820815	18-2337	3850814
58FBPNCA	1996	18-2339	3852384	18-2146	3820815	18-2337	3850814
58FBPMDA	1994	18-2339	3852384	18-2146	3820815	18-2337	3850814
58FCPNCA	1996	18-2339	3852384	18-2146	3820815	18-2337	3850814
58FCPNCS	1996	18-2339	3852384	18-2146	3820815	18-2337	3850814
74FEPHUB	1995	18-2339	3852384	18-2146	3820815	18-2337	3850814
74FFPNCA	1996	18-2339	3852384	18-2146	3850815	18-2337	3850814
74FGPLKD	1997	18-2339	3852384	18-2146	3820815	18-2337	3850814
74FGPNCS	1996	18-2339	3852384	18-2146	3850815	18-2337	3850814
74FHPLYC	1998	18-2339	3852384	18-2146	3820815	18-2337	3850814
74FHPPBYC	1998	18-2339	3852384	18-2146	3820815	18-2337	3850814
74FJPBYC	1998	18-2339	3852384	18-2146	3820815	18-2337	3850814
74FJPBYC	1998	18-2339	3852384	18-2146	3820815	18-2337	3850814
74FJPBYD	1998	18-2339	3852384	18-2146	3820815	18-2337	3850814
74FJPYD	1998	18-2339	3852384	18-2146	3820815	18-2337	3850814
82FCPBYC	1998	18-2339	3852384	18-2146	3820815	18-2337	3850814
302CCPMDA	1994	18-2339	3852384	18-2146	3820815	18-2337	3850814
302CGPMDA	1994	18-2339	3852384	18-2146	3820815	18-2337	3850814
302CMBYC	1998	18-2339	3852384	18-2146	3820815	18-2337	3850814
302CMBYM	1998	18-2339	3852384	18-2146	3820815	18-2337	3850814
302CMHUB	1995	18-2339	3852384	18-2146	3820815	18-2337	3850814
302CMLKD	1997	18-2339	3852384	18-2146	3850815	18-2337	3850814
302CMNCA	1996	18-2339	3852384	18-2146	3820815	18-2337	3850814
302CMNCS	1996	18-2339	3852384	18-2146	3820815	18-2337	3850814
302CPBYC	1998	18-2339	3852384	18-2146	3820815	18-2337	3850814
302CPBYM	1998	18-2339	3852384	18-2146	3820815	18-2337	3850814
302CPHUB	1995	18-2339	3852384	18-2146	3820815	18-2337	3850814
302CPLKD	1997	18-2339	3852384	18-2146	3850815	18-2337	3850814
302CPNCA	1996	18-2339	3852384	18-2146	3820815	18-2337	3850814
302CPNCS	1996	18-2339	3852384	18-2146	3820815	18-2337	3850814
302DCMMDA	1994	18-2339	3852384	18-2146	3820815	18-2337	3850814
302DGMMDA	1994	18-2339	3852384	18-2146	3820815	18-2337	3850814
432ACMMDA	1994	18-2339	3852384	18-2146	3820815	18-2337	3850814
432ACPMDA	1994	18-2339	3852384	18-2146	3820815	18-2337	3850814
432AGMMDA	1994	18-2339	3852384	18-2146	3820815	18-2337	3850814

APPLICATION CONTINUED ON NEXT PAGE

- ① Used where raw w/p is located on outdrive ② Used where raw w/p is located on engine ③ Excludes Model 58FBPMDA, used where raw w/p is located on engine
 ④ Used where raw w/p is located on engine, incl. Model 58FBPMDA

Model	Year	U-Joint #	U-Joint Assy. OE #	Long Yoke #	Long Yoke OE #	Short Yoke #	Short Yoke OE #
432AGPMDA	1994	18-2339	3852384	18-2146	3820815	18-2337	3850814
432APNCA	1996	18-2339	3852384	18-2146	3820815	18-2337	3850814
432BPLKD	1997	18-2339	3852384	18-2146	3820815	18-2337	3850814
432BPNCS	1996	18-2339	3852384	18-2146	3820815	18-2337	3850814
502APHUB	1995	18-2339	3852384	18-2146	3820815	18-2337	3850814
502APHUE	1995	18-2339	3852384	18-2146	3820815	18-2337	3850814
432ACMMDA	1994	18-2339	3852384	18-2146	3820815	18-2337	3850814
432ACPMDA	1994	18-2339	3852384	18-2146	3820815	18-2337	3850814
432AGMMDA	1994	18-2339	3852384	18-2146	3820815	18-2337	3850814
432AGPMDA	1994	18-2339	3852384	18-2146	3820815	18-2337	3850814
432BPBYC	1998	18-2339	3852384	18-2146	3820815	18-2337	3850814
432BPLKD	1997	18-2339	3852384	18-2146	3820815	18-2337	3850814
434APNCA	1996	18-2339	3852384	18-2146	3820815	18-2337	3850814
434BPBYC	1998	18-2339	3852384	18-2146	3820815	18-2337	3850814
434BPLKD	1997	18-2339	3852384	18-2146	3820815	18-2337	3850814
434BPNCS	1996	18-2339	3852384	18-2146	3820815	18-2337	3850814
502ACPMDA	1994	18-2339	3852384	18-2146	3820815	18-2337	3850814
502AGPMDA	1994	18-2339	3852384	18-2146	3820815	18-2337	3850814
502APHUB	1995	18-2339	3852384	18-2146	3850815	18-2337	3850814
502APHUE	1995	18-2339	3852384	18-2146	3850815	18-2337	3850814
502APNCA	1996	18-2339	3852384	18-2146	3820815	18-2337	3850814
502APNCS	1996	18-2339	3852384	18-2146	3820815	18-2337	3850814
502BPBYC	1998	18-2339	3852384	18-2146	3820815	18-2337	3850814
572ACPMDA	1994	18-2339	3852384	18-2146	3820815	18-2337	3850814
572AGPMDA	1994	18-2339	3852384	18-2146	3820815	18-2337	3850814
572BPBYC	1998	18-2339	3852384	18-2146	3820815	18-2337	3850814
572BPLKD	1997	18-2339	3852384	18-2146	3820815	18-2337	3850814
572BPLKR	1997	18-2339	3852384	18-2146	3820815	18-2337	3850814
572BPNCS	1996	18-2339	3852384	18-2146	3820815	18-2337	3850814
574BPLKD	1997	18-2339	3852384	18-2146	3820815	18-2337	3850814
584ACPMDA	1994	18-2339	3852384	18-2146	3820815	18-2337	3850814
584AGPMDA	1994	18-2339	3852384	18-2146	3820815	18-2337	3850814
584APHUB	1995	18-2339	3852384	18-2146	3820815	18-2337	3850814
584APHUE	1995	18-2339	3852384	18-2146	3820815	18-2337	3850814
584APNCA	1996	18-2339	3852384	18-2146	3820815	18-2337	3850814
584APNCS	1996	18-2339	3852384	18-2146	3820815	18-2337	3850814
744DCPMDM	1994	18-2339	3852384	18-2146	3820815	18-2337	3850814
744DCPMDA	1994	18-2339	3852384	18-2146	3820815	18-2337	3850814
744DDPMDA	1994	18-2339	3852384	18-2146	3820815	18-2337	3850814
744DDPMDM	1994	18-2339	3852384	18-2146	3820815	18-2337	3850814
744DGPMDA	1994	18-2339	3852384	18-2146	3820815	18-2337	3850814
744DGPMMDM	1994	18-2339	3852384	18-2146	3820815	18-2337	3850814
744DJPMDA	1994	18-2339	3852384	18-2146	3820815	18-2337	3850814
744DJPMMDM	1994	18-2339	3852384	18-2146	3820815	18-2337	3850814
744DPHUB	1995	18-2339	3852384	18-2146	3820815	18-2337	3850814
744EPNCA	1996	18-2339	3852384	18-2146	3850815	18-2337	3850814
744FPLKD	1997	18-2339	3852384	18-2146	3850815	18-2337	3850814
744FPNCS	1996	18-2339	3852384	18-2146	3850815	18-2337	3850814

① Used where raw w/p is located on outdrive ② Used where raw w/p is located on engine
 ③ Excludes Model 58FBDPMDA, used where raw w/p is located on engine ④ Used where raw w/p is located on engine, incl. Model 58FBDPMDA

**18-2772-1
TRANSOM
SEAL KIT**

For: SX Cobra Drives with cone clutch

— CONTAINS —

Part #	Description	O.E. #	Qty.
18-2100	Gimbal Bearing	3853807	1
18-2765	Bellows	3854127	1
18-1074	Bellows	3850426-2	1
18-2996	Seal	3852560, 911823	1
18-710-64-2	Hose Clamp	853012-3	1

















**18-2771
BELLOWS KIT**
Replaces: 3854270



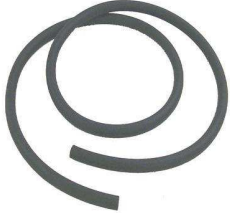

For: OMC Cobra without cone clutch

— CONTAINS —

Part #	Description	O.E. #
18-2613	Outdrive Gasket Set	—
18-2765	U-Joint Bellows	983973, 987467
18-2764	Exhaust Bellows	914036
18-2763	Shift Cable Bellows	911826
18-2100	Gimbal Bearing	983937
18-710-64-2	Hose Clamp	—



 <p>18-2128 CENTER SOCKET Replaces: 912213, 3850813 Fits all OMC Cobra</p>	 <p>18-2745 EXHAUST BOOT Replaces: 912374 Fits 5.7L & 7.5L (1986 & later)</p>	 <p>18-1074 EXHAUST BELLOW I.D. 2 5/8" x O.D. 3" x L 7.5" Replaces: 3850426 All cone clutch models (1994-up) not using exhaust boot</p>	 <p>18-2763 SHIFT CABLE BELLOWS Replaces: 911826 ALL COBRA</p>
 <p>18-2764 EXHAUST BELLOWS Replaces: 914036 All clutch dog Cobra models (1986-93)</p>	 <p>18-2765 U-JOINT BELLOWS I.D. 3 1/2" x O.D. 4" x L 6" Replaces: 983973, 987467, 3854127 All clutch dog Cobra models (1986-93)</p>	 <p>18-21754 ENGINE COUPLER Replaces: 986232, 984537 Fits: 7.5L / 460 King Cobra 1987-90</p>	 <p>18-21751 ENGINE COUPLER Replaces: 3853962, 983902, 986338 Fits: 2.5L (1986), 3.0L (1986-90), (4.3L, 5.0L, 5.7L) (1986) KW & KWB suffix only, 7.4L (1990-98), 8.2L (1992-93, 1998)</p>
 <p>18-21752-1 ENGINE COUPLER Replaces: 3858437, 984290, 986120, 3853917 Fits: 4.3L (1986-98), 5.0L (1986-88, 1998) 5.7 (1986-92, 1994, 1996-98)</p>	 <p>18-21753 ENGINE COUPLER Replaces: 3853862 Fits: 5.0L & 5.8L (1989-96)</p>	 <p>18-21755 ENGINE COUPLER Replaces: 984629 2.3L Cobra</p>	 <p>18-2533 TRANSOM SEAL Replaces: 911797</p>
 <p>18-2767 TRANSOM SEAL 16 hole Replaces: 313080 (1967-77) 120 HP and UP</p>	 <p>18-2768 TRANSOM SEAL 22 hole Replaces: 909527 (1978-86) — ALL</p>	 <p>18-2245-1 SHIFT CABLE ASSEMBLY Replaces: 987661 Wire: 68" • Jacket: 58 1/2" For: 1988-1993 OMC Cobra (except King) without cone clutch</p>	 <p>18-2246 SHIFT CABLE ASSEMBLY Replaces: 987678 Wire: 59" For: King Cobra</p>

 <p>18-3769 PINION NUT Replaces: 911753 For: 115 (1994-97), 232 (1987-90), 252 (1986), 262, 350, 460 (1989), 302, 574 (1986-92), 432 (1986-93), 502 (1988-93), 504, 754 (1986-88), 584 (1989-93), 744 (1988), 90 Jet (1994-95)</p>	 <p>18-3719 PINION NUT Replaces: 314730 (⁵/₈ - 18)</p>	 <p>18-2176 BALL GEAR (Intermediate Housing) Replaces: 908063 1973-86</p>	 <p>18-2177 BALL GEAR (Upper Gear Case) Replaces: 908069 1973-86</p>	
<p>PKG. OF 5</p>  <p>18-3725 18-3725-9^① BALL GEAR NUT Replaces: 908064</p>	<p>PKG. OF 2</p>  <p>18-3731 18-3731-9^① LOCKNUT Replaces: 907866 ³/₄ - 16</p>	<p>PKG. OF 5</p>  <p>18-4251 18-4251-9^① PLUG Replaces: 908062 O.D. 1.748</p>	 <p>18-4835 CENTERING CONE Replaces: 912029 Fits: OMC Cobra (1986-93) without cone clutch</p>	 <p>18-1750 COMPLETE BEARING HOUSING For: Cobra Drives & V6</p>
 <p>18-1154 BALL BEARING Replaces: 377139</p>	 <p>18-1161 TAPERED ROLLER BEARING Replaces: 983891</p>	 <p>18-1170 LOWER PINION BEARING Replaces: 983892</p>	 <p>18-1171 U-JOINT SHAFT BEARING Replaces: 983878</p>	 <p>18-1172 CARRIER BEARING Replaces: 983877 For: 1986-95 Cobra</p>
 <p>18-1158 CARRIER BEARING Replaces: 387247</p>	 <p>18-1350 CARRIER BEARING Replaces: 379504</p>	 <p>18-1351 CARRIER BEARING Replaces: 382407 COBRA</p>	 <p>18-1117 PINION BEARING Replaces: 387817</p>	 <p>18-1357 PINION BEARING Replaces: 384195 COBRA</p>
 <p>18-1358 REVERSE GEAR BEARING Replaces: 389039 COBRA</p>	 <p>18-1365 THRUST BEARING Replaces: 387656 COBRA DRIVE SHAFT</p>	 <p>18-1366 THRUST BEARING Replaces: 382408 COBRA REVERSE GEAR</p>	 <p>18-1370 THRUST FORWARD BEARING Replaces: 389042</p>	 <p>18-1371 THRUST FORWARD BEARING Replaces: 385043 COBRA</p>

^① Priced per Package

APPLICATION BEINGS ON NEXT PAGE

OMC 400 & 800 SERIES GEARCASE BEARINGS

HP	Year	Pinion Bearing	Drive Shaft Bearing	Carrier Aft Bearing	Carrier Fore Bearing	Forward Thrust Bearing	Reverse Thrust Bearing	Housing Bearing
120	1978-81	18-1357	18-1365	18-1350	18-1351	18-1371	18-1366	—
2.5L	1982-86	18-1357	18-1365	18-1350	18-1351	18-1371	18-1366	18-1351
140	1978-81	18-1357	18-1365	18-1350	18-1351	18-1371	18-1366	—
3.0L	1982-86	18-1357	18-1365	18-1350	18-1351	18-1371	18-1366	18-1351
185/3.8L	1978-85	18-1117	18-1365	18-1158	18-1351	18-1370	18-1366	18-1358
4.3L	1985-86	18-1117	18-1365	18-1158	18-1351	18-1370	18-1366	18-1358
200/5.0L	1979-86	18-1117	18-1365	18-1158	18-1351	18-1370	18-1366	18-1358
225	1978	18-1117	18-1365	18-1158	18-1351	18-1370	18-1366	18-1358
230/530L	1979-86	18-1117	18-1365	18-1158	18-1351	18-1370	18-1366	18-1358
240	1978	18-1117	18-1365	18-1158	18-1351	18-1370	18-1366	18-1358
250	1979	18-1117	18-1365	18-1158	18-1351	18-1370	18-1366	18-1358
260/5.7L	1979-86	18-1117	18-1365	18-1158	18-1351	18-1370	18-1366	18-1358

OMC COBRA GEAR HOUSING BEARINGS

Model	Liter	Year	Pinion Bearing	Drive Shaft Bearing	Carrier Aft Bearing	Carrier Fore Bearing	Forward Thrust Bearing	Reverse Thrust Bearing	Housing Bearing
2.3L	2.3L	1987	18-1357	18-1365	18-1350	18-1351	18-1371	18-1366	18-1351
2.3L	2.3L	1988-1990	18-1357	18-1365	18-1350	18-1351	18-1371	18-1366	N/A
2.5L	2.5L	1986	18-1357	18-1365	18-1350	18-1351	18-1371	18-1366	18-1351
3.0L	3.0L	1986-1987	18-1357	18-1365	18-1350	18-1351	18-1371	18-1366	18-1351
3.0L	3.0L	1988-1989	18-1357	18-1365	18-1350	18-1351	18-1371	18-1366	N/A
3.0L	3.0L	1990-1991	18-1117	18-1365	18-1158	18-1351	18-1370	18-1366	N/A
3.0L	3.0L	1992-1993	18-1117	18-1365	N/A	18-1351	18-1370	18-1366	N/A
3.0L HO	3.0L	1992-1993	18-1117	18-1365	N/A	18-1351	18-1370	18-1366	N/A
4.3L	4.3L	1986-1987	18-1117	18-1365	18-1158	18-1351	18-1370	18-1366	18-1358
4.3L	4.3L	1988-1991	18-1117	18-1365	18-1158	18-1351	18-1370	18-1366	N/A
4.3L	4.3L	1992-1993	18-1117	18-1365	N/A	18-1351	18-1370	18-1366	N/A
4.3L HO	4.3L	1992-1993	18-1117	18-1365	N/A	18-1351	18-1370	18-1366	N/A
5.0L	5.0L	1986-1987	18-1117	18-1365	18-1158	18-1351	18-1370	18-1366	18-1358
5.0L	5.0L	1988-1991	18-1117	18-1365	18-1158	18-1351	18-1370	18-1366	N/A
5.0L	5.0L	1992-1993	18-1117	18-1365	N/A	18-1351	18-1370	18-1365	N/A
5.0L HO	5.0L	1992-1993	18-1117	18-1365	N/A	18-1351	18-1370	18-1365	N/A
5.7L	5.7L	1986-1987	18-1117	18-1365	18-1158	18-1351	18-1370	18-1366	18-1358
5.7L	5.7L	1988-1991	18-1117	18-1365	N/A	18-1351	18-1370	18-1365	N/A
5.7L	5.7L	1992-1993	18-1117	18-1365	N/A	18-1351	18-1370	18-1366	N/A
5.8L	5.8L	1989-1991	18-1117	18-1365	N/A	18-1351	18-1370	18-1366	N/A
5.8L	5.8L	1992-1993	18-1117	18-1365	N/A	18-1351	18-1370	18-1366	N/A

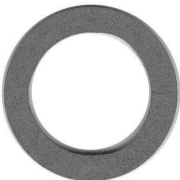

18-0195
THRUST WASHER
 Replaces: 314731
 COBRA



18-0198
FORWARD GEAR THRUST WASHER
 Replaces: 324766

PKG. OF 2



18-2243
18-2243-9①
DETENT BALL
 Replaces: 316506
 For: V-4 & V-6 gearcase
 OMC Sterndrive 400 Series (1978-79);
 800 Series (1978)



18-1501
DETENT BALL
 Replaces: 160084
 For: Cobra drives (1980& Earlier)



18-1701
LOWER DRIVE SHAFT
 Replaces: 911693
 For: Cobra Drives 262, 302, 350,
 432, 434, 502, 504, 574, 584



18-2183
DRIVE SHAFT
 Replaces: 909121

① Priced per Package



18-2184
DRIVE SHAFT
 Replaces: 908087



18-2185
DRIVE SHAFT
 Replaces: 909753



18-2186
DRIVE SHAFT
 Replaces: 982424
 800 Drives



18-2187
PROP SHAFT
 Replaces: 395209
 Cobra & Late Model 800 Drives



18-2251
PROP SHAFT
 Replaces: 435022, 433017, 436740



18-2252
PROP SHAFT
 Replaces: 387818, 436888



18-2216
SLIDING CLUTCH
 Replaces: 337772, 337774,
 334516, 336562, 910995



18-2220
SLIDING CLUTCH
 Replaces: 323664, 320630



18-2383
SLIDING CLUTCH
 Replaces: 914716, 915272
 For: 3.0L (GM), 4.3L (GM), 5.0L (Ford), 5.7L (Ford),
 5.8L (Ford) (1990-91)



18-2218
FORWARD GEAR SET
 Replaces: 434063, 987966,
 985050, 436746



18-2219
REVERSE GEAR
 Replaces: 333077,
 317838, 340490



18-1600
UPPER GEAR KIT
with bearing
 Replaces: 983825
 For: 5.7, 5.8L V-8 Cobra drives (21:16 ratio)



18-1601
UPPER GEAR KIT
with bearing
 Replaces: 983826
 For: 5.0L V-8 engines-Cobra drives (21:18 ratio)



18-1602
UPPER GEAR KIT
 Replaces: 984012
 For: 4.3L V-6 engines-Cobra drives (21:19 ratio)

APPLICATION BEGINS ON NEXT PAGE

SHAFT/GEAR/SLIDING CLUTCH APPLICATION

Model	Year	Bearing Carrier Shaft	Short/Long Water Pump Shaft	Drive Shaft	Prop Shaft	Forward Gear	Reverse Gear	Sliding Clutch
100 thru 165	1973	—	18-2185	—	—	—	—	—
120 thru 190	1974-75	—	18-2185	—	—	—	—	—
120 thru 235 ⑥	1976-77	—	18-2184	—	—	—	—	—
120 thru 190 ⑤	1976	—	18-2185	—	—	—	—	—
120/140 ⑤	1977	—	18-2185	—	—	—	—	—
120/140	1978-81	18-2183	18-2185	—	18-2252	—	—	18-2220
120 thru 235 ⑥	1977	—	18-2184	—	—	—	—	—
175/190/235 ⑤	1977	18-2183	18-2185	—	—	—	—	—
185	1978	18-2183	18-2185	18-2186	—	—	—	—
185	1980-81	18-2183	18-2185	18-2186	—	—	—	—
200	1979	18-2183	18-2185	18-2186	—	—	—	—
200	1980-81	18-2183	18-2185	18-2186	—	—	—	—
225/245	1973-75	—	18-2184	—	—	—	—	—
225	1978	18-2183	18-2185	18-2186	—	—	—	—
225	1979	—	—	18-2186	—	—	—	—
225	1980	—	—	18-2186	—	—	—	—
225	1981	—	—	18-2186	—	—	—	—
230	1979	18-2183	18-2185	18-2186	—	—	—	—
230	1980-81	18-2183	18-2185	18-2186	—	—	—	—
235	1975	18-2183	18-2185	—	—	—	—	—
235 ⑤	1976-77	18-2183	18-2185	—	—	—	—	—
240	1978	18-2183	18-2185	18-2186	—	—	—	—
240	1979	—	—	18-2186	—	—	—	—
240	1980-81	—	—	18-2186	—	—	—	—
250	1979	18-2183	18-2185	18-2186	—	—	—	—
260	1979	18-2183	18-2185	18-2186	—	—	—	—
260	1980-81	18-2183	18-2185	—	—	—	—	—
262	1989	—	—	—	18-2187	—	—	—
2.3/3.0	1987-89	—	—	—	18-2252	—	18-2219	—
2.3	1990	—	—	—	18-2252	—	—	—
2.5	1986	18-2183	18-2185	—	18-2252	—	18-2219	—
2.5	1982-87	18-2183	18-2185	—	18-2252	18-2218	18-2219	—
350 ③	1988-89	—	—	—	18-2187	18-2218	—	—
3 ①	1982-86	18-2183	18-2185	—	18-2252	18-2218	18-2219	18-2216
3.0/4.3 ③	1990-91	—	—	—	18-2187	—	—	18-2383
3.0/4.3	1992-93	—	—	—	18-2251	—	—	18-2383
3.0 H.O.	1990-91	—	—	—	18-2187	—	—	18-2383
3.0 H.O.	1992-93	—	—	—	18-2251	—	—	18-2383
3.8	1982-86	18-2183	18-2185	18-2186	18-2187	—	—	18-2216
460 ③	1988-89	—	—	—	18-2187	—	—	18-2216
4.3 ①	1985-86	18-2183	18-2185	18-2186	18-2187	—	—	18-2216
4.3 ②	1986-87	—	—	—	18-2187	—	—	—
4.3 ③	1988-91	—	—	—	18-2187	—	—	18-2383 ⑨
4.3 H.O.	1990-91	—	—	—	18-2187	—	—	18-2383
4.3 H.O.	1992-93	—	—	—	18-2251	—	—	18-2383
5.0/5.7	1982-83	18-2183	18-2185	18-2186	—	—	—	18-2216
5.0/5.7 ①	1984-86	18-2183	18-2185	18-2186	18-2187	—	—	18-2216
5 ②	1986-87	—	—	—	18-2187	—	—	—
5	1988	—	—	—	18-2187	—	—	—
5 ③	1988-91	—	—	—	18-2187	—	—	18-2383 ⑨
5.0/5.7	1992	—	—	—	18-2251	—	—	18-2383
5.0 H.O.	1990-91	—	—	—	18-2187	—	—	18-2383
5.0 H.O.	1992-93	—	—	—	18-2251	—	—	18-2383
5.7	1987-88	—	—	—	18-2187	—	—	—
5.7 ③	1988-89	—	—	—	18-2187	—	—	—
5.7 ⑧ ③	1990-92	—	—	—	18-2187	—	—	18-2383
5.8 ③	1989-90	—	—	—	18-2187	—	—	18-2383 ⑨
5.8	1991	—	—	—	18-2187	—	—	18-2383
5.8	1992-93	—	—	—	18-2251	—	—	18-2383
7.5	1987	—	—	—	18-2187	—	—	18-2216

① Except Cobra
② Cobra

③ Right hand rotation drive
⑤ Low profile

⑥ High profile
⑧ Except L.E. models

⑨ 1990-93 models only



18-1702
CARRIER BEARING
Replaces: 438039, 5000074
For: 1 3/16" diameter prop shaft-Cobra drives (1986-90) Fits all stringer mounts except 2.5L & 3.0L (1978-85)



18-1703
CARRIER BEARING
Replaces: 434400, 435096, 438040, 5000363, 5004257
For: 1 1/4" diameter prop shaft Cobra drives (1991-93)



18-4828
PINION BEARING CARRIER
 Replaces: 911750
 Fits: OMC Cobra (1986-93) without cone clutch



18-1099
BEARING HOUSING & SEAL ASSEMBLY
 Replaces: 982422
 For: OMC Stringer Drive-120, 140, 170, 200, 230, 260, (1981), 252, 302, 382, 502, 504 & 574 (1982-85), 432 (1985)



18-1343
BEARING CARRIER RETAINING TAB
 Replaces: 333957
 For: Cobra drives & V-6



18-0655
SHIFT ROD
 Replaces: 914736
 3.0L (1990-1993), 4.3L, 5.0L, 5.7L, 5.8L (1986-1993)



18-0647
SHIFT ROD ASSEMBLY
 Replaces: 986658
 3.0L (1990-1993), 4.3L, 5.0L, 5.7L, 5.8L (1986-1993)



18-0652
ROD END, SHIFT
 Replaces: 914723
 3.0L (1990-1993), 4.3L, 5.0L, 5.7L, 5.8L (1986-1993)



18-0653
SCREW, SHIFT ROD END
 Replaces: 308825
 3.0L (1990-1993), 4.3L, 5.0L, 5.7L, 5.8L (1986-1993)



18-0654
NUT, SHIFT ROD END
 Replaces: 914743
 3.0L (1990-1993), 4.3L, 5.0L, 5.7L, 5.8L (1986-1993)



18-3766
SHIFT CRADLE
 Replaces: 334163
 For: V-4/V-6, Cobra, Stringer



18-3610
RETAINER NUT
 Replaces: 911752
 Fits: OMC Cobra (1986-93) without cone clutch



18-3768
COVER NUT
 Replaces: 911751
 For: Cobra Drives 115 (1994-97), 232 (1987-90), 252 (1986) 262 (1989), 302 (1987)

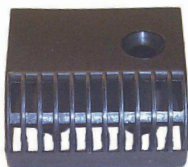





















18-1500
INTAKE WATER SCREEN
 Replaces: 337778
 For: 100, 120, 125, 140, 150, 175, 200, 225 (1993) (OMC Cobra & V6)



18-4750
COVER ASSEMBLY
 Replaces: 983967
 Fits: 2.3L (1987-90), 2.5L (1986), 2.6L (1989), 3.0L (1986-93), 4.3L (1986-93), 5.0L (1986-94), 5.7L (1986-92), 5.8L (1989-93), 7.4L (1988)

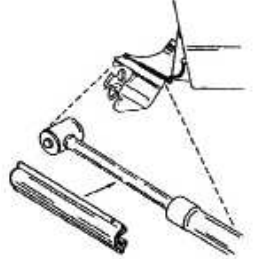

18-1714
CLUTCH DOG PIN
 Replaces: 313448
 For: 50-85, 100, 135, 140, 150, 175, 200, 235 (1969-82) (OMC Stringer drive)

 <p>18-2399 CLUTCH DOG Replaces: 324369 For: V-4 & V-6</p>	 <p>18-4222 THRUST WASHER Replaces: 318841</p>	 <p>18-4223 THRUST WASHER Replaces: 333592</p>	 <p>18-4228 PROP SPACER Replaces: 315810</p>											
 <p>18-4194 PROP SPACER Replaces: 3852350 For: 1994 King Cobra Lower Units</p>	 <p>18-4231 PROP SPACER Replaces: 320570</p>	<p>PKG. OF 5</p>  <p>18-3705 18-3705-9^① PROP NUT Replaces: 314503</p>	 <p>18-3708-1 PROP NUT & KEEPER Replaces: 398042</p>											
 <p>18-3730 LOCK NUT Replaces: 3852648 For: Cobra & King Cobra 1987-94</p>	<p>② 18-3733D </p>  <p>18-3733 PROP NUT KIT For: SX Cobra</p>	<p>② 18-3715D </p>  <p>18-3715 PROP NUT KIT — CONTAINS —</p> <table border="1"> <thead> <tr> <th>Part #</th> <th>O.E. #</th> <th>Description</th> </tr> </thead> <tbody> <tr> <td>18-3708-1</td> <td>398042</td> <td>Prop Nut/Keeper</td> </tr> <tr> <td>18-3741</td> <td>309955</td> <td>Cotter Pin</td> </tr> <tr> <td>18-4231</td> <td>320570</td> <td>Prop Spacer</td> </tr> </tbody> </table>	Part #	O.E. #	Description	18-3708-1	398042	Prop Nut/Keeper	18-3741	309955	Cotter Pin	18-4231	320570	Prop Spacer
Part #	O.E. #	Description												
18-3708-1	398042	Prop Nut/Keeper												
18-3741	309955	Cotter Pin												
18-4231	320570	Prop Spacer												
<p>② 18-3716D </p>  <p>18-3716 PROP NUT KIT Replaces: 175267 — CONTAINS —</p> <table border="1"> <thead> <tr> <th>Part #</th> <th>O.E. #</th> <th>Description</th> </tr> </thead> <tbody> <tr> <td>18-3705</td> <td>314503</td> <td>Prop Nut</td> </tr> <tr> <td>18-3742</td> <td>314502</td> <td>Cotter Pin</td> </tr> <tr> <td>18-4238</td> <td>315810</td> <td>Prop Spacer</td> </tr> </tbody> </table>	Part #	O.E. #	Description	18-3705	314503	Prop Nut	18-3742	314502	Cotter Pin	18-4238	315810	Prop Spacer	 <p>18-4444 PROP WRENCH FOR ALL COBRA</p>	 <p>18-2156 TILT SHAFT Replaces: 980183 I/O 1964-86 EXCEPT COBRA</p>
Part #	O.E. #	Description												
18-3705	314503	Prop Nut												
18-3742	314502	Cotter Pin												
18-4238	315810	Prop Spacer												
<p>PKG. OF 10</p>  <p>COTTER PINS</p> <p>18-3741 18-3741-9^① 309955</p> <p>18-3742 18-3742-9^① 314502</p> <p>Replaces: 314502</p>	 <p>18-9098 TRAILERING CLIPS Replaces: 174448 Set of 2 For all Cobra Stern Drives</p>  <p></p>													
<p align="center">APPLICATION BEGINS ON NEXT PAGE</p> <p>① Priced per Package ② Items ending in "D" are Display Packaged - Regular number is Non-Display</p>														

NUT/SPACER/WASHER/COTTER PIN/PROP NUT KIT APPLICATION

Model	Year	Nut	Spacer	Washer	Cotter Pin	Prop Nut Kit	Model	Year	Nut	Spacer	Washer	Cotter Pin	Prop Nut Kit
120	1978-81	18-3705	18-4228	18-4222	18-3742	18-3716	460	1989-90	18-3708-1	18-4231	18-4223	18-3741	18-3715
140	1978-81	18-3705	18-4228	18-4222	18-3742	18-3716	502	1992	18-3708-1	18-4231	18-4223	18-3741	18-3715
185	1978-80	18-3708-1	18-4231	18-4223	18-3741	18-3715	2.3	1987-90	18-3705	18-4228	18-4222	18-3742	18-3716
200	1979-81	18-3708-1	18-4231	18-4223	18-3741	18-3715	2.5	1982-86	18-3705	18-4228	18-4222	18-3742	18-3716
225	1978	18-3708-1	18-4231	18-4223	18-3741	18-3715	3	1982-89	18-3705	18-4228	18-4222	18-3742	18-3716
230	1979	18-3708-1	18-4231	18-4223	18-3741	18-3715	3	1990-92	18-3708-1	18-4231	18-4223	18-3741	18-3715
240	1978	18-3708-1	18-4231	18-4223	18-3741	18-3715	3.8	1981-85	18-3708-1	18-4231	18-4223	18-3741	18-3715
260	1979-81	18-3708-1	18-4231	18-4223	18-3741	18-3715	4.3	1985-92	18-3708-1	18-4231	18-4223	18-3741	18-3715
262	1987-89	18-3708-1	18-4231	18-4223	18-3741	18-3715	5	1982-92	18-3708-1	18-4231	18-4223	18-3741	18-3715
350	1988-91	18-3708-1	18-4231	18-4223	18-3741	18-3715	5.7	1979-92	18-3708-1	18-4231	18-4223	18-3741	18-3715
351	1992	18-3708-1	18-4231	18-4223	18-3741	18-3715	5.8	1989-92	18-3708-1	18-4231	18-4223	18-3741	18-3715
454	1990-92	18-3708-1	18-4231	18-4223	18-3741	18-3715	7.5	1987	18-3708-1	18-4231	18-4223	18-3741	18-3715

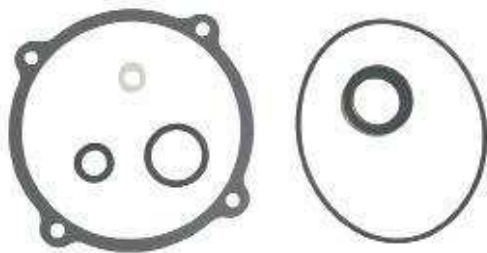

18-2698

CLUTCH HOUSING SEAL KIT

Fits: All models 1977 & below

— CONTAINS —

Part #	Desc.	O.E. #	Qty.
18-7114	O-RING	302540	1
18-7400	O-RING	908194	1
18-7952	OIL SEAL	911019	1
18-2863	GASKET, COVER	308799	1
18-4248	GASKET, OIL DRAIN	311598	1
18-0939	GASKET, DIPSTICK	315189	1



18-8360

CLUTCH HOUSING SEAL KIT

Fits: All models 1978 & above

— CONTAINS —

Part #	Desc.	O.E. #	Qty.
18-2060	OIL SEAL	321467	2
18-7114	O-RING	302540	1
18-7168	O-RING	202893	2
18-7400	O-RING	908194	1
18-2863	GASKET, COVER	308799	1
18-4248	GASKET, OIL DRAIN	311598	2
18-0939	GASKET, DIPSTICK	315189	1

HP	Year	Clutch Pack Seal Kit	HP	Year	Clutch Pack Seal Kit	HP	Year	Clutch Pack Seal Kit	HP	Year	Clutch Pack Seal Kit
80	1968-1969	18-2698	140	1980-1981	18-8360③	190	1974-1977	18-2698	230	1980-1981	18-8360②
90	All	18-2698	3.0L	1982-1985	18-8360	200	1966-1968	18-2698	235	All	18-2698
100	1972-1973	18-2698	155	1967-1972	18-2698	200	1979-1980	18-2698①	240	1978	18-2698
120	1965-1978	18-2698	165	1972-1976	18-2698	200	1980-1981	18-8360②	245	1972-1975	18-2698
120	1979-1980	18-2698①	3.8L	1981-1983	18-8360	5.0L	1982-1985	18-8360	250	1979	18-2698
120	1980-1985	18-8360③	170	1974	18-2698	210	1968-1970	18-2698	260	1979-1980	18-2698①
2.5L	1982-1985	18-8360	175	1975-1977	18-2698	215	1971	18-2698	260	1980-1981	18-8360②
140	1973-1978	18-2698	185	1967-1968	18-2698	225	All	18-2698	5.7L	1982-1985	18-8360
140	1979-1980	18-2698①	185	1978	18-2698	230	1979-1980	18-2698①			

① 1980 Models with the "C" suffix

② 1980 Models with "K" or "U" suffix

③ 1980 Models with "C1" suffix

Zinc is for saltwater only applications.
Magnesium is for fresh water only applications.
Aluminum is for brackish water, or if boat is used in both fresh and salt environments.



⑤ 18-6019
ANODE

Replaces: 982277, 982438
For intermediate housing on Stringer Drive models



⑤ 18-6020
ANODE

Replaces: 976669
For Stringer Drive models with central grounding point on boat hull



⑤ 18-6024
④ 18-6024A
ANODE

Replaces: 393023, 436745
(1982-87) For use on gearcases

④ Aluminum

⑤ Zinc

 <p>⑤ 18-6025 ANODE Replaces: 433458, 398331</p>	 <p>③ 18-6027 ANODE Replaces: 392123 For exhaust housing, V4 & V6 (1983-90)</p>	 <p>③ 18-6028 ① 18-6028A ② 18-6102 ANODE Replaces: 984513, 3853818, 3855412 For use on Gearcases: 2.3L (1987-90), 2.6L/3.5L/4.6L (1989), 3.0L /4.3L/5.0L/5.8L (1987-93), 5.7L (1987-92), 7.4L (1987-88)</p>	
 <p>③ 18-6029 ANODE Replaces: 397768</p>	 <p>③ 18-6095 ① 18-6095A ANODE Replaces: 431708 For use on gearcases (1988-90)</p>	 <p>③ 18-6101 ANODE Replaces: 983494 For: Cobra Lower Unit (1987) 2.5, 3.0, 4.3, 5.0, 5.7</p>	
 <p>③ 18-6103 ① 18-6103A ANODE Replaces: 984547 For use on Transom Mounts: 2.3L/3.0L (1987-89), 2.6L (1989)</p>	 <p>③ 18-6155Z ANODE KIT For: Cobra Drives except King Cobra</p>	<p>PKG. OF 5</p>  <p>18-3722 18-3722-9④ STAINLESS STEEL LOCKNUT Replaces: 121731 (1/4"—28)</p>	
 <p>18-2454 DRAIN PLUG Replaces: 3854539 3/8" - 16 thread Uses O-ring 18-7145 For: Cobra SX drives</p>	 <p>18-2138 PIVOT PIN BEARING Replaces: 911787 COBRA (2 per Drive)</p>	 <p>18-7634 TRIM SENDER Replaces: 984748 Fits: OMC Cobra</p>	
<p>① Aluminum ② Magnesium ③ Zinc ④ Priced per Package</p>			



18-2663
LOWER UNIT
SEAL KIT

Replaces: 981797
100-245 Stringer Unit (1968-77)

— CONTAINS —

Part #	Desc.	O.E. #	Qty.
18-0168	Grommet	908594	1
18-2012	Oil Seal	310599	4
18-2020	Oil Seal	310649	1
18-2058	Oil Seal	313353	2
18-2851	Swivel Bearing To Lower Gear Case Gsk.	313368	1
18-4248	Washer	311598	2
18-7120	O-Ring	307853, 322598	4
18-7129	O-Ring	314491	1
18-7135	O-Ring	310584	1
18-7167	O-Ring	310414	1



18-2664
LOWER UNIT
SEAL KIT

Replaces: 982947
4 cyl (400) Stringer Unit (1978-86)

— CONTAINS —

Part #	Desc.	O.E. #	Qty.
18-0110	Shift Housing Gasket	324670	1
18-3133	Housing Screw	908158	2
18-0188	Washer	909748	1
18-2020	Oil Seal	310649	1
18-2058	Oil Seal	313353	2
18-2060	Oil Seal	321467	2
18-3722	Locknut	121731	4
18-4248	Washer	311598	2
18-7101	O-Ring	305739	1
18-7102	O-Ring	307450	1
18-7120	O-Ring	307853, 322598	1
18-7127	O-Ring	313446	1
18-7130	O-Ring	314728	1
18-7178	O-Ring	320140	1
18-7404	O-Ring	909747	1
18-7475	Quad Ring	332583	4
18-7168	O-Ring	202893	1
18-7409	O-Ring	911871	2
18-2001	Oil Seal	330137	2
18-7479	O-Ring	—	1
18-3153	S.S. Bolt	908158	2

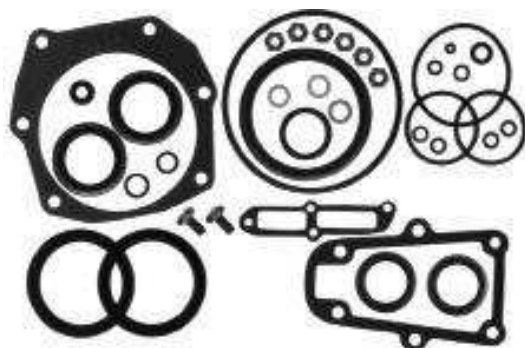

18-2665
LOWER UNIT
SEAL KIT

Replaces: 982946
V6,V8 (800) Stringer Unit (1978-86)

— CONTAINS —

Part #	Desc.	O.E. #	Qty.
18-0110	Shift Housing Gasket	324670	1
18-3133	Housing Screw	908158	2
18-0188	Washer	909748	1
18-2002	Oil Seal	320862	2
18-2020	Oil Seal	310649	1
18-2058	Oil Seal	313353	2
18-2060	Oil Seal	321467	2
18-2911	Swivel Bearing Housing Gasket	910236	1
18-3722	Locknut	121731	6
18-4248	Washer	311598	2
18-7101	O-Ring	305739	1
18-7102	O-Ring	307450	1
18-7120	O-Ring	307853, 322598	1
18-7130	O-Ring	314728	1
18-7142	O-Ring	322119	1
18-7178	O-Ring	320140	1
18-7403	O-Ring	909316	2
18-7404	O-Ring	909747	1
18-7475	Quad Ring	332583	4
18-7168	O-Ring	202893	1
18-7479	O-Ring	—	1
18-3153	S.S. Bolt	908158	2



18-2666
UPPER UNIT SEAL KIT

Replaces: 981799
100-245 Stringer Unit (1968-72)

— CONTAINS —

Part #	Desc.	O.E. #	Qty.
18-0939	Upper Gearcase Gasket	315189	1
18-2073	Oil Seal	981268	4
18-3111	Rubber Seal	907774	1
18-4248	Washer	311598	2
18-7103	O-Ring	308624	4
18-7107	O-Ring	313175	1
18-7121	O-Ring	308621	1
18-7134	O-Ring	303059	1
18-7146	O-Ring	554545	1
18-7173	O-Ring	910582	1
18-7198	O-Ring	308626	2
18-7158	O-Ring	310585, 310967	1
18-7172	O-Ring	553126	1

— CONTAINS —

Part #	Desc.	O.E. #	Qty.
18-0939	Upper Gearcase Gasket	315189	1
18-2072	Oil Seal	0765461	2
18-2073	Oil Seal	981268	2
18-3111	Rubber Seal	907774	1
18-3725	Locknut	908064	1
18-4248	Washer	311598	2
18-4251	Plug	908062	1
18-7107	O-Ring	313175	1
18-7114	O-Ring	302540	1
18-7121	O-Ring	308621	1
18-7129	O-Ring	314491	1
18-7477	Quad Ring	909048	1
18-7168	O-Ring	202893	1
18-7172	O-Ring	553126	1
18-7173	O-Ring	910582, 310327	1



18-2667
UPPER UNIT SEAL KIT
 Replaces: 982949
 All Stringer Unit (1973-86)

— CONTAINS —

Part #	Desc.	O.E. #	Qty.
18-0917	Tilt Motor Gasket	311508	1
18-0923	Seal Gasket	313244	2
18-0939	Upper Gearcase Gasket	315189	1
18-0949	Trunion Cap Gasket	316499	2
18-2004	Oil Seal	—	1
18-2016	Oil Seal	0764337	2
18-2066	Oil Seal	911019	1
18-2071	Oil Seal	981195	2
18-3725	Locknut	908064	1
18-4248	Washer	311598	1
18-4251	Plug	908062	1
18-7114	O-Ring	302540	1
18-7162	O-Ring	302337	1
18-7400	O-Ring	908194	1
18-7401	O-Ring	908383	1
18-7198	O-Ring	308626	2
18-2863	Tilt Clutch Cover Gasket	308799	1



18-2669
INTERMEDIATE HOUSING SEAL KIT
 Replaces: 981801
 100-245 Stringer Unit (1973-77)

— CONTAINS —

Part #	Desc.	O.E. #	Qty.
18-0880	Shift Cover Gasket	911878	1
18-0166	Grommet	911705	2
18-0190	Wiper	912157	1
18-4248	Washer	311598	2
18-7127	O-Ring	313446	1
18-7130	O-Ring	314728	1
18-7137	O-Ring	318372	1
18-7138	O-Ring	318717	3
18-7145	O-Ring	333572	2
18-7475	Quad Ring	332584	5
18-2001	Oil Seal	330137	2



18-2671
LOWER UNIT SEAL KIT
 Replaces: 985612
 All 4 cyl. Cobra (1986-89)

— CONTAINS —

Part #	Desc.	O.E. #	Qty.
18-0880	Shift Cover Gasket	911878	1
18-0166	Grommet	911705	2
18-0190	Wiper	912157	1
18-2002	Oil Seal	320862	2
18-4248	Washer	311598	2
18-7130	O-Ring	314728	1
18-7137	O-Ring	318372	1
18-7138	O-Ring	318717	3
18-7142	O-Ring	322119	1
18-7145	O-Ring	333572	2
18-7475	Quad Ring	332584	5
18-0440	Water Passage Gasket	915719	1



18-2672
LOWER UNIT SEAL KIT
 Replaces: 984458, 985613, 439967
 All V6/V8 Cobra (1986-1991)



18-2673
UPPER UNIT SEAL KIT
 Replaces: 984459, 986364, 987603
 All Cobra (1986-89)

— CONTAINS —

Part #	Desc.	O.E. #	Qty.
18-0911	Water Pump Base Gasket	911698	1
18-0884	Water Cover Gasket	911733	1
18-0166	Grommet	911705	2
18-2067	Oil Seal	911685	1
18-2068	Oil Seal	3853655	1
18-2541	Rubber Seal	911704	1
18-2916	Water Pump Housing Gasket	911702	1
18-2918	Outdrive Gasket	915840	1
18-2996	Seal	911823	1
18-7107	O-Ring	313175	1
18-7116	O-Ring	303067	1
18-7138	O-Ring	318717	2
18-7153	O-Ring	—	2
18-7169	O-Ring	911686	1
18-7403	O-Ring	909316	1
18-7407	O-Ring	911700	1



18-2674
TRANSOM MOUNT SEAL KIT
 Replaces: 985518, 986423
 All Cobra (1986-89)

— CONTAINS —

Part #	Desc.	O.E. #	Qty.
18-2070	Oil Seal	911795	1
18-2138	Bearing	911787	3
18-2139	Bearing	911794	1
18-2533	Foam Seal	911797	1
18-2918	Outdrive Gasket	915840, 911836	1
18-2996	Seal	911823	1
18-4250	Washer	911820	2
18-7141	O-Ring	321117	12
18-7143	O-Ring	322501	1
18-7162	O-Ring	302337	1
18-7165	O-Ring	304174	1
18-7406	O-Ring	911311	3
18-7408	O-Ring	911718	2
18-7409	O-Ring	911871	1
18-7168	O-Ring	202893	1
18-8349	Seal	3852548	1



18-2783
LOWER UNIT SEAL KIT
 Replaces: 986629
 King Cobra Lower Unit - 1990



18-2791
GEARCASE SEAL KIT
 Replaces: 987251, 3850597
 Fits: 3.0L, 4.3L, 5.0L (1994), 3.2L (1992-93),
 5.7L (1992-94), 7.4L (1992-95), 8.2L (1992-93)

APPLICATION ON NEXT PAGE



SEAL KIT APPLICATION

Model	Year	Lower Gearcase Seal Kit	Upper Gearcase Seal Kit	Intermediate Housing Seal Kit	Transom Mount Seal Kit	Model	Year	Lower Gearcase Seal Kit	Upper Gearcase Seal Kit	Intermediate Housing Seal Kit	Transom Mount Seal Kit
2.3	1987-90	18-2671	18-2673	N/A	18-2674	165	1972	18-2663	18-2666	18-2668	N/A
2.5 ①	1982-86	18-2664	18-2667	N/A	N/A	165	1973-76	18-2663	18-2667	18-2669	N/A
2.5 ②	1986	18-2671	18-2673	N/A	18-2674	170	1974	18-2663	18-2667	18-2669	N/A
3 ①	1982-86	18-2664	18-2667	N/A	N/A	175	1975-77	18-2663	18-2667	18-2669	N/A
3 ②	1986-91	18-2671	18-2667	N/A	N/A	185	1968	18-2663	18-2666	18-2668	N/A
4.3 ①	1985-86	18-2665	18-2667	N/A	N/A	185	1978-80	18-2665	18-2667	N/A	N/A
4.3 ②	1986-91	18-2672	18-2673	N/A	18-2674	190	1974-77	18-2663	18-2667	18-2669	N/A
3.8	1981-86	18-2665	18-2667	N/A	N/A	200	1968	18-2663	18-2666	18-2668	N/A
5 ①	1982-86	18-2665	18-2667	N/A	N/A	200	1979-81	18-2665	18-2667	N/A	N/A
5 ②	1986-91	18-2672	18-2673	N/A	18-2674	210	1968-70	18-2663	18-2666	18-2668	N/A
5.7 ①	1982-86	18-2665	18-2667	N/A	N/A	215	1971	18-2663	18-2666	18-2668	N/A
5.7 ②	1986-89	18-2672	18-2673	N/A	18-2674	225	1972	18-2663	18-2666	18-2668	N/A
5.7 ③	1990-91	18-2672	18-2673	N/A	18-2674	225	1973-76	18-2663	18-2667	18-2669	N/A
5.8	1989-90	18-2672	18-2673	N/A	18-2674	225	1978	18-2665	18-2667	N/A	N/A
7.5	1987	—	18-2673	N/A	18-2674	230	1979-81	18-2665	18-2667	N/A	N/A
80	1969	18-2663	18-2666	18-2668	N/A	235	1971	18-2663	18-2666	18-2668	N/A
90	1970	18-2663	18-2666	18-2668	N/A	235	1975-77	18-2663	18-2667	18-2669	N/A
100	1972	18-2663	18-2666	18-2668	N/A	240	1978	18-2665	18-2667	N/A	N/A
100	1973	18-2663	18-2667	18-2669	N/A	245	1972	18-2663	18-2666	18-2668	N/A
120	1968-72	18-2663	18-2666	18-2668	N/A	245	1973-75	18-2663	18-2667	18-2669	N/A
120	1973-77	18-2663	18-2667	18-2669	N/A	250	1979	18-2665	18-2667	N/A	N/A
120	1978-81	18-2664	18-2667	N/A	N/A	260	1979-81	18-2665	18-2667	N/A	N/A
140	1973-77	18-2663	18-2667	18-2669	N/A	262	1989	18-2672	18-2673	N/A	18-2674
140	1978-81	18-2664	18-2667	N/A	N/A	350	1988-89	18-2672	18-2673	N/A	18-2674
155	1968-72	18-2663	18-2666	18-2668	N/A	460	1988-89	—	18-2673	N/A	18-2674

① Except Cobra ② Cobra ③ Except L.E. N/A Not Applicable

OIL SEALS



Part #	O.E. #	Shaft Size	Dimensions (in)		Part #	O.E. #	Shaft Size	Dimensions (in)	
			O.D.	Width				O.D.	Width
18-0542	321831, 315288	0.750	1.253	0.186	18-2061	329922	0.822	1.375	0.195
18-0543	321895,	1.540	1.926	0.243	18-2062	329923	0.875	1.375	0.207
	313507				18-2063	330327	0.625	1.124	0.188
18-0559	332585	0.285	0.357	0.940	18-2064	332205	0.730	1.130	0.194
18-2000	309989	1.375	2.000	0.313	18-2065	332261	0.625	1.375	0.195
18-2001	330137	1.125	1.624	0.250	18-2066	911019	1.000	1.375	0.435
18-2002	320862	1.188	1.692	0.250	18-2067	911685	2.000	2.509	0.315
18-2005	313284	0.625	1.128	0.250	18-2068	3853655	0.500	0.905	0.250
18-2012	310599	1.000	1.499	0.250	18-2068	915702	0.500	0.905	0.250
18-2016	0764337	1.187	1.875	0.250	18-2068	916058	0.500	0.905	0.250
18-2018	0767970	1.000	1.375	0.250	18-2068	3853655	0.500	0.905	0.200
18-2020	310649	2.500	3.000	0.250	18-2071	908065, 908852	1.500	2.125	0.250
18-2022	303345	0.554	1.000	0.375	18-2072	0765461, 908894, 908070	1.750	2.502	0.250
18-2023	313282	0.554	1.062	0.312	18-2073	907967, 981268	1.625	2.502	0.250
18-2024	314167	0.425	0.937	0.312	18-8349	3852548	1.375	2.186	0.500
18-2025	318972	0.500	0.875	0.250					
18-2027	305306, 321459	0.625	1.125	0.250					
18-2030	321786	0.625	1.125	0.188					
18-2031	321787	0.625	1.125	0.312					
18-2033	321928	0.625	1.375	0.250					
18-2034	324639	0.437	0.937	0.188					
18-2058	313353	1.938	2.438	0.250					
18-2059	318223	0.750	1.126	0.200					
18-2060	321467	1.000	1.375	0.250					

UPPER GEARCASE (Cobra)					UPPER GEARCASE (Stringer)				
ENGINE	YEAR	OIL SEAL	DESC.	QTY	ENGINE	YEAR	OIL SEAL	DESC.	QTY
262 - 460	1988-89	18-2067	BC	1	80 - 245	1968-72	18-2073	BGS	1
262 - 460	1988-90	18-2068	WPS	1	80 - 260	1969-81	18-2073	IH	2
2.3 - 7.5	1986-90	18-2068	WPS	1	88 - 200	1964-66	18-2000	BGS	1
2.3 - 7.5 ①	1986-90	18-2067	BC	1	90	③ 1967	18-2000	BGS	1
① 5.7 '90 574 AMPWS, ARPWS					90	④ 1967	18-2073	BGS	1
BC Bearing Carrier Seal					100 - 245	1972-73	18-2073	BGS	1
WPS Water Pump Seal					100 - 260	1973-81	18-2072	BGS	2
					120	① 1967	18-2073	BGS	1
					120	② 1967	18-2000	BGS	1
					120	① 1967	18-2073	IH	2
					120 - 210	1968	18-2073	IH	2
					155	1967	18-2073	IH	2
					155	⑤ 1967	18-2000	BGS	1
					155	1967	18-2073	BGS	1
					185	1967	18-2000	BGS	1
					200	⑥ 1967	18-2000	BGS	1
					200	⑦ 1967	18-2073	IH	2
					200	⑦ 1967	18-2073	BGS	1
					2.5 - 5.7	1981-86	18-2072	BGS	2
					2.5 - 5.7	1981-86	18-2073	IH	2
					① CU, CUE 16C Models		⑥ TU, TUE 15S Models		
					② CU15S Models		⑦ TU, TUE 16C Models		
					③ DU, DUE 14D Models		BGS Ball Gear Shaft Seal		
					④ DU, DUE 15S Models		IH Impeller Housing Seal		
					⑤ HU, HUE 15S Models				
LOWER GEARCASE (Stringer)					LOWER GEARCASE (Cobra)				
ENGINE	YEAR	OIL SEAL	DESC.	QTY	ENGINE	YEAR	OIL SEAL	DESC.	QTY
80/90	1968-71	18-2066	BR,L	2	262 - 460	1988-89	18-2002	PS	2
80/90	1968-71	18-2066	PS	2	2.3	1990	18-2001	PS	2
88/90	1964-68	18-2012	BR	1	2.3 - 3.0	1986-89	18-2001	PS	2
80 - 260	1968-81	18-2020	BR,U	1	3	1990	18-2002	PS	2
80 - 260	1968-81	18-2058	BR,M	2	4.3 - 7.5	1986-90	18-2002	PS	2
110 - 200 ①	1964-67	18-2012	BR	2					
110 - 245 ①	1964-77	18-2012	PS	2	PS Prop Shaft Seal				
110/120 ②	1964-67	18-2012	BR	1					
120 - 245	1968-77	18-2012	BR,L	2	INTERMEDIATE HOUSING (Stringer)				
120 - 260	1978-81	18-2060	BR,L	2	ENGINE	YEAR	OIL SEAL	DESC.	QTY
120/140	1978-81	18-2001	PS	2	80 - 235	1964-71	18-2000	BG,O	1
155 ③	1967	18-2058	BR,M	2	80 - 245	1964-72	18-2001	BG,I	1
155 ③	1967	18-2020	BR,U	1	80 - 260 ②	1964-80	18-2066	CL	1
185 - 260	1978-81	18-2002	PS	2	100 - 245	1972	18-2000	BG,O	2
210 - 260 ④	1972-75	18-2066	IH	1	100 - 260	1973-79	18-2016	BG,I	1
230/260 ④	1976	18-2060	IH	1	100 - 260	1973-81	18-2071	BG,O	2
305/350/454 ④	1977-78	18-2060	IH	1	120 - 260	1980-81	18-2016	BG,I	2
2.5/3.0	1982-86	18-2001	PS	2	120 - 260 ①	1980-81	18-2060	CL	2
2.5 - 5.7	1981-86	18-2020	BR,U	1	2.5 - 5.7	1981-86	18-2060	CL	2
2.5 - 5.7	1981-86	18-2058	BR,M	2	2.5 - 5.7	1981-86	18-2016	BG,I	2
2.5 - 5.7	1981-86	18-2060	BR,L	2	2.5 - 5.7	1981-86	18-2071	BG,O	2
3.8 - 5.7	1981-86	18-2002	PS	2					
① 110, 120 HP '64-67 Hvy. Duty Dr.					CL Clutch				
② Standard Drive					① 120, 140 '80C Models/185—260				
③ HU, HUE 16 C Models					'80 K&U Models				
④ Inboard					② C Models in '80				
BR Driveshaft Bearing Retainer Seal					BG,I Driveshaft Ball Gear Inner Seal				
BR,U Driveshaft Bearing Retainer Upper Seal					BG,O Driveshaft Ball Gear Outer Seal				
BR,M Driveshaft Bearing Retainer Middle Seal									
BR,L Driveshaft Bearing Retainer Lower Seal									
IH Impeller Housing Seal									
PS Prop Shaft Seal									



O-RINGS

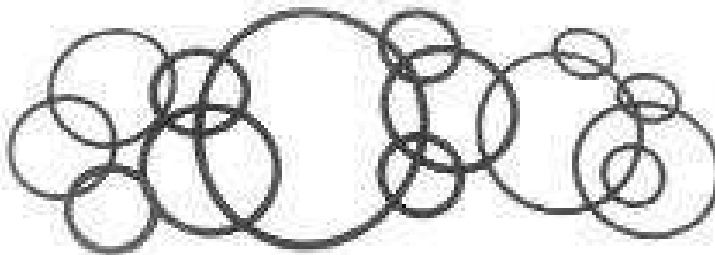

Part #	O.E. #	Dimensions (in)		Part #	O.E. #	Dimensions (in)	
		I.D.	Width			I.D.	Width
18-7100	② ⑤ 301877	.245	.155	18-7150	③ ⑤ 331380	.225	.115
18-7101	② ⑤ 305739	.250	.065	18-7150	③ ⑤ 334913	.225	.115
18-7102	② ⑤ 307450	.430	.065	18-7152	② ⑤ 307082	2.625	.135
18-7103	② ⑤ 308624	.920	.100	18-7153	① 3852565,		
18-7104	② ⑤ 308627	2.210	.135		911851	.0860	.100
18-7105	② ⑤ 311338	.750	.065	18-7155	② ⑤ 305270	1.620	.135
18-7107	② ⑤ 313175	4.750	.135	18-7156	② ⑤ 309731	1.185	.100
18-7108	② ⑤ 313893	2.550	.100	18-7158	② ⑤ 310585	.740	.100
18-7108	② ⑤ 338518	2.550	.100	18-7162	② ⑤ 302337	2.025	.135
18-7109	② ⑤ 317178	.214	.048	18-7164	② ⑤ 302537	1.375	.100
18-7111	① 301824	.197	.113	18-7165	② ⑤ 304174	.500	.065
18-7112	① 302493	1.170	.135	18-7167	② ⑤ 310414	3.625	.135
18-7114	② ⑤ 302540	1.000	.135	18-7168	② ⑤ 202893	.370	.065
18-7115	① 302588	1.735	.135	18-7169	② ⑤ 911686	3.500	.135
18-7116	① 303067	.360	.100	18-7170	① 307239	1.365	.135
18-7117	① 303360	1.060	.135	18-7172	② ⑤ 553126	3.250	.135
18-7118	② ⑤ 305242	.300	.135	18-7173	② ⑤ 310327	1.875	.135
18-7120	① 307853	.215	.065	18-7174	② ⑤ 326649	.620	.100
18-7120	① 332598	.215	.065	18-7178	② ⑤ 320140	.920	.135
18-7121	① 308621	3.100	.135	18-7180	② ⑤ 303347	.445	.090
18-7123	① 308876	2.235	.100	18-7198	② ⑤ 308626	1.430	.100
18-7126	① 313340	1.690	.100	18-7400	② ⑤ 908194	4.000	.100
18-7127	① 313446	3.315	.135	18-7401	② ⑤ 908383	2.485	.100
18-7128	① 313754	1.835	.100	18-7403	② ⑤ 909316	1.500	.100
18-7129	② ⑤ 314491	.970	.065	18-7404	② ⑤ 909747	.300	.100
18-7130	① 314728	2.125	.100	18-7406	② ⑤ 911311	0.250	.065
18-7133	② ⑤ 305123	3.780	.135	18-7407	② ⑤ 911700	4.125	.135
18-7134	② ⑤ 303059	.500	.100	18-7407	② ⑤ 3852531	4.125	.135
18-7135	① 310584	.750	.135	18-7408	② ⑤ 911718	1.060	.100
18-7137	② ⑤ 318372	0.320	.155	18-7409	② ⑤ 911871	1.175	.100
18-7138	② ⑤ 318717	1.500	.210	18-7413	② ⑤ 303191	.301	.070
18-7139	② ⑤ 319085	1.080	.210	18-7416	② ⑤ 329380	.612	.103
18-7140	② ⑤ 320303	2.750	.135	18-7417	② ⑤ 329381	.362	.103
18-7141	② ⑤ 321117	.180	.065	18-7418	② ⑤ 326741	4.484	.139
18-7142	② ⑤ 322119	3.940	.135	18-7440-1	④ 301967	.799	.103
18-7143	② ⑤ 322501, 331188	1.310	.100	18-7457	① 319662	1.799	.103
18-7144	② ⑤ 326849	4.250	.135	18-7461	① 308458	1.612	.103
18-7145	② ⑤ 333572	.250	.100	18-7475	② ⑤ 332584	.250	.065
18-7146	② ⑤ 554545	1.120	.100	18-7477	② ⑤ 909048	.480	.100
18-7150	③ ⑤ 303598	.225	.115	18-7510	① 321163	2.750	.070

① Pkg. of 1 ② Pkg. of 5 ③ Pkg. of 10 ④ Indicates Quad Rings rather than O-Rings

TRANSOM MOUNT (Cobra)					TRANSOM MOUNT (Cobra) (Cont.)				
ENGINE	YEAR	O-RING	DESC.	QTY.	ENGINE	YEAR	O-RING	DESC.	QTY.
262 - 460	1988-89	18-7165	SCS	1	2.3 - 7.5 ①	1986-90	18-7165	SCS	1
262 - 460	1988-89	18-7408	NP	2	2.3 - 7.5 ①	1986-90	18-7409	SC	1
262 - 460	1988-89	18-7409	SC	1	2.3 - 7.5	1986-90	18-7143	MB	1
262 - 460	1988-89	18-7406	PL	1					
262 - 460	1988-89	18-7168	BC	1					
262 - 460	1988-90	18-7162	UG	1					
262 - 460	1988-90	18-7143	MB	1					
2.3 - 7.5 ①	1986-90	18-7168	BC	1					
2.3 - 7.5	1986-90	18-7162	UG	1					
2.3 - 7.5 ①	1986-90	18-7406	PL	1					
2.3 - 7.5 ①	1986-90	18-7408	NP	2					

① 5.7 '90 574 AMPWS, ARPWS
BC Bell Crank Seal
MB Manifold Block Seal
UG Upper Gimbal Seal
SCS Shift Cable Seal
PL Plug Seal
NP Nipple Seal
SC Sleeve and Connector Seal

⑤ This product is priced per piece. To order priced per package, please add -9 to the part number.

UPPER GEARCASE (Cobra)

ENGINE	YEAR	O-RING	DESC.	QTY
262 - 460	1988-89	18-7403	A,S	1
262 - 460	1988-89	18-7107	GHC	1
262 - 460	1988-89	18-7407	A,L	1
262 - 460	1988-90	18-7169	BC	1
350 - 460	1990	18-7116	OFF	1
350 - 460	1990	18-7407	BC	1
350 - 460	1990	18-7406	WDP	1
370	1988	18-7407	AB	1
460	1990	18-7407	BC	1
2.3 - 5.8	1990	18-7116	OFF	1
2.3 - 7.5	① 1986-90	18-7107	GHC	1
2.3 - 7.5	① 1986-90	18-7407	A,L	1
2.3 - 7.5	1986-90	18-7169	BC	1
2.3 - 7.5	① 1986-90	18-7403	A,S	1
5.7	② 1990	18-7406	WDP	1
5.7	② 1990	18-7407	BC	1

- ① 5.7 '90 574 AMPWS, ARPWS
- ② 574 PEPWS
- GHC** Gear Hsg. Cover Seal
- OFF** Oil Fill Plug Seal
- BC** Bearing Carrier Seal
- A,S** Adaptor, Small Seal
- A,L** Adaptor, Large Seal
- WDP** Water Drain Plug Seal
- AB** Anchor Block Seal

LOWER GEARCASE (Cobra)

ENGINE	YEAR	O-RING	DESC.	QTY
262/350	1988-89	18-7475	PBHS	4
262/350	1988-89	18-7142	PBH	1
262 - 460	1988-89	18-7130	DS B	1
262 - 460	1988-89	18-7475	BSS	1
262 - 460	1988-89	18-7138	DS BH	3
262 - 460	1988-89	18-7137	SR	1
350 - 460	1990	18-7145	PL	1
370	1988	18-7130	SL	2
370/460	1988-89	18-7145	D&F S	2
2.3	1987	18-7145	D&F S	2
2.3	1990	18-7127	PBH	1
2.3 - 3.0	1986-89	18-7127	PBH	1
2.3/3.0	1988-90	18-7145	D&F S	2
2.5 - 5.7	1986	18-7145	D&F S	2
2.3 - 5.8	① 1986-90	18-7475	PBHS	4
2.3 - 7.5	① 1986-90	18-7475	BSS	1
2.3 - 7.5	① 1986-90	18-7138	DS BH	3
2.3 - 7.5	① 1986-90	18-7137	SR	1
2.3 - 7.5	① 1986-90	18-7130	DS B	1
3.0 - 5.8	① 1990	18-7142	PBH	1
4.3 - 5.8	1989-89	18-7142	PBH	1
5.7	② 1990	18-7145	PLUG	1

- ① 5.7 '90 574 AMPWS, ARPWS
- ② 574 PEPWS
- BSS** Bearing Setscrew Seal
- DS BH** Driveshaft Bearing Hsg. Seal
- DS B** Driveshaft Bearing Seal
- D&F S** Drain & Fill Screw Seal
- PBH** Prop Bearing Hsg. Seal
- PBHS** Prop Bearing Hsg. Screw Seal
- PL** Plug Seal
- SR** Shift Rod Seal
- SL** Sleeve Seal

POWER TILT AND TRIM (Cobra)

ENGINE	YEAR	O-RING	DESC.	QTY
262 - 460	1988-90	18-7141	OL	12
262 - 460	1988-90	18-7102	PL	1
350 - 460	1988	18-7174	VSH	1
350 - 460	1988	18-7168	VS	4
350 - 460	1988	18-7174	VA,L	2
350 - 460	1988	18-7165	VA,S	2
2.3 - 7.5	1986-88	18-7174	VSH	1
2.3 - 7.5	1986-88	18-7168	VS	4
2.3 - 7.5	1986-88	18-7174	VA,L	2
2.3 - 7.5	1986-88	18-7165	VA,S	2
2.3-7.5	1986-90	18-7102	PL	1
2.3-7.5	1986-90	18-7141	OL	12

- PL** Plug Seal
- VS** Valve Seat Assy. Seal
- VA,L** Valve Assy., Large Seal
- VA,S** Valve Assy., Small Seal
- VSH** Valve Seat Hsg. Seal
- OL** Oil Line Seal

OIL AND COOLING SYSTEM (Cobra)

ENGINE	YEAR	O-RING	DESC.	QTY
262/454	1989-90	18-7135	AR	1
262 - 460	1988-90	18-7116	ODF	1
350/460	1988-90	18-7135	AR	1
370	1988	18-7162	THERM	1
2.3 - 5.8	1988-90	18-7116	ODF	1
4.3	① 1990	18-7135	AR	1
7.5	1987	18-7135	AR	1

- ① V-4 Only
- ODF** Oil Drain Fitting Seal
- AR** Adapter Retainer Seal
- THERM** Thermostat Seal

POWERHEAD (Stringer)

ENGINE	YEAR	O-RING	DESC.	QTY
80/90	1969-71	18-7108	WP	1
88	1964	18-7133	CCH	3
88/90	1964-68	18-7120	CCHS	4
90	1965-68	18-7133	CCH	4
120/140	1977-80	18-7114	CP	1
120 - 235	1976	18-7114	CP	1

- WP** Water Pump Seal
- CCH** Crankcase Head Seal
- CCHS** Crankcase Head Screw Seal
- CP** Coupling Seal

INTERMEDIATE HOUSING (Stringer)

ENGINE	YEAR	O-RING	DESC.	QTY
80	1968	18-7162	SL	1
80 - 90	1964-68	18-7174	WT	1
80 - 210	1964-70	18-7123	BGR	1
80 - 245	① 1964-72	18-7174	PS	1
80 - 260	1964-81	18-7198	COV	2
80 - 260	1964-81	18-7114	WR	1
80 - 260	1969-81	18-7162	SL	1
88	1964	18-7104	TH	1
88	1964	18-7174	TC	1

INTERMEDIATE HOUSING (Stringer) (Cont.)				
ENGINE	YEAR	O-RING	DESC.	QTY
90 - 235	1970-71	18-7158	DS	1
90 - 235	② 1971	18-7123	BGR	1
100 - 260	1973-81	18-7401	BGR	1
100 - 260	1973-81	18-7400	TUC	1
120	③ 1967	18-7162	SL	1
120 - 210	1968	18-7162	SL	1
120/140	1981	18-7168	FS	3
155	④ 1967	18-7162	SL	1
2.5 - 5.7	1981-86	18-7400	TUC	1
2.5 - 5.7	1981-86	18-7198	COV	2
2.5 - 5.7	1981-86	18-7114	WR	1
2.5 - 5.7	1981-86	18-7401	BGR	1
2.5 - 5.7	1981-86	18-7162	SL	1
2.5 - 5.7	1982	18-7168	FS	3

- ① Rope or Pull-Pull Steering Models
- ② All 90/120, 155, 210 EX Models/235 XUFM20S prior to S/N 202880 and 235 XUFM20S prior to S/N 204600
- ③ CU, CUE 16C
- ④ 120, 155, 215, 20D Models/235 XUFR20S S/N 202880 & up and 235 XUFM20S S/N 204600 & up 235 20D all Models
- COV** Pivot Cap Cover Seal
- BGR** Ball Gear Retainer Seal
- DS** Driveshaft to Hsg. Seal
- TC** Driveshaft Tube Cover Seal
- TH** Driveshaft Tube to Hsg.
- FS** Fill Screw Seal
- PS** Pulley Shaft
- SL** Sleeve to Hsg. Seal
- TUC** Tilt Unit Cover Seal
- WT** Water Tube Seal
- WR** Worm Gear Retainer Seal

UPPER GEARCASE (Stringer)

ENGINE	YEAR	O-RING	DESC.	QTY
80 - 90	1968-71	18-7158	BG	1
80 - 90	1964-68	18-7174	IH	1
80 - 245	① 1964-72	18-7103	WG	1
80 - 245	① 1964-74	18-7134	G	1
80 - 260	1964-81	18-7172	IH	1
80 - 260	1964-81	18-7121	BGR	1
80 - 260	1968-80	18-7173	WW	1
80 - 260	② 1968-81	18-7107	WW	1
90	③ 1967	18-7107	WW	1
90 - 200	1964-67	18-7128	CAP	1
90 - 200	1965-67	18-7173	WW	2
90 - 245	④ 1967-72	18-7146	BG	1
100 - 245	1973-75	18-7114	WS	1
100 - 260	1973-81	18-7129	DS IH	1
110 - 120	⑤ 1964-67	18-7158	IH	1
110 - 120	⑥ 1964-67	18-7174	IH	1
120 - 200	⑦ 1967	18-7107	WW	1
120 - 235	1968-71	18-7158	IH	1
120 - 260	1975-81	18-7477	G	1
150 - 210	1964-67	18-7158	IH	1
2.5/3.0	1982	18-7168	OP	1
2.5 - 5.7	1981-86	18-7477	G	1
2.5 - 5.7	1981-86	18-7172	IH	1
2.5 - 5.7	1981-86	18-7107	WW	1
2.5 - 5.7	1981-86	18-7121	BGR	1
2.5 - 5.7	1981-86	18-7129	DS IH	1

UPPER GEARCASE (Stringer) (Cont.)

- ① Rope or Pull-Pull Steering Models
- ② 155 HP 1968 HU, HUE 16C
- ③ DU, DUE 15S
- ④ 90 HP '67 DU, DUE 15S/120 and 200 '67 16C Models
- ⑤ Heavy Duty Drive
- ⑥ Standard Gearcase
- ⑦ 16C Models
- BG** Ball Gear Seal
- BGR** Ball Gear Retainer Seal
- DS IH** Driveshaft Impeller Hsg. Seal
- IH** Impeller Hsg. Seal
- CAP** Gear Hsg. Cap Seal
- OP** Oil Plug Seal
- WR** Steering Worm Wheel Retainer Seal
- WS** Steering Worm Wheel Spacer Seal
- WG** Steering Worm Wheel Gear Seal
- WW** Steering Worm Wheel Seal
- G** Gear Seal

LOWER GEARCASE (Stringer)

ENGINE	YEAR	O-RING	DESC.	QTY
80 - 90	1964-69	18-7120	PBH S	4
80 - 90	1964-71	18-7152	PBH	1
80 - 90	1964-71	18-7115	BR	1
80 - 90	1964-71	18-7174	DS	1
88/90	1964-68	18-7173	DSB	2
90 - 245	1970-77	18-7120	PBH S	4
100 - 245	1968-72	18-7135	BR	1
100 - 245	1969-77	18-7167	PBH	1
110/120	② 1964-67	18-7167	PBH	1
110/120	① 1964-67	18-7174	DS	1
110/120	② 1964-67	18-7135	BR	1
110/120	① 1964-67	18-7152	PBH	1
110/120	① 1964-67	18-7173	DSB	2
110/120	① 1964-67	18-7115	BR	1
120	① 1964-67	18-7120	PBH S	4
120/140	1978-81	18-7127	PBH	1
120/140	1978	18-7156	SA,L	2
120 - 235	1977	18-7129	DS	1
120 - 240	1978	18-7178	SA,S	1
120 - 260	1978-81	18-7130	BR	1
120 - 260	1978-81	18-7102	PIN	1
120 - 260	1978-81	18-7109	PBH S	4
120 - 260	1978-81	18-7404	PIN	1
120 - 260	1979-81	18-7120	BSS	1
120 - 260	1981	18-7168	D&F S	1
150 - 200	1964-67	18-7135	BR	1
150 - 210	1964-68	18-7167	PBH	1
185 - 240	1978	18-7403	SA,L	2
185 - 260	1978-81	18-7142	PBH	1
2.5 - 5.7	1981-82	18-7168	D&F S	1
2.5 - 5.7	1981-83	18-7109	PBH S	4
2.5 - 5.7	1981-86	18-7130	BR	1
2.5 - 5.7	1981-86	18-7102	PIN	1
2.5 - 5.7	1981-86	18-7404	PIN	1
2.5 - 5.7	1981-86	18-7120	BSS	1
2.5 - 5.7	1981-86	18-7142	PBH	1
2.5/3.0	1982-86	18-7127	PBH	1
3.8	1981	18-7101	OSV	1

- ① Standard Drive
- ② Heavy Duty Drive
- OSV** Oil Stem Valve Seal
- PIN** Pinion Shaft Seal
- BR** Driveshaft Bearing Retainer Seal
- DS** Driveshaft Seal
- PBH** Prop Bearing Hsg. Seal
- DSB** Driveshaft Bushing Seal
- PBH S** Prop Bearing Hsg. Screw Seal
- D&F S** Drain & Fill Screw Seal
- SA,L** Shift Assy., Large Seal
- SA,S** Shift Assy., Small Seal
- BSS** Bearing Set Screw Seal