

MERCURY OUTBOARD											
HP	CYL	BEG. S/N	YEAR	HP	CYL	BEG. S/N	YEAR	HP	CYL	BEG. S/N	YEAR
2.2	1	8075603	1984	8	2	C221500	1990	35	2	1755799	1965
2.2	1	8087123	1985	9.8	2	5206550	1979	35	2	1960827	1966
2.2	1	A800761	1986	9.8	2	5541280	1980-81	35	2	2097800	1967
2.2	1	A805221	1987	9.8	2	5965263	1982	35	2	2300972	1968
2.2	1	A817421	1988	9.8	2	6263906	1983	35	2	2487558	1969
2.2	1	A837101	1989	9.8	2	6438338	1984	35	2	6445653	1984
3	1	A855097	1990	9.8	2	6620196	1985	35	2	6626696	1985
3.4 L	6	6436883	1984	9.8 (100)	2	1397581	1961	35	2	A922171	1986
3.4 L	6	A129445	1985	9.8 (110)	2	1455240	1962	35	2	B110789	1987
3.4 L	6	A912426	1986	9.8 (110)	2	1474328	1963	35	2	B238644	1988
3.5	1	6202173	1983	9.8 (110)	2	1607083	1964	35	2	B393190	1989
3.5	1	6434771	1984	9.8 (110)	2	1742746	1965	35 (300)	4	1271885	1960
3.5	1	6594744	1985	9.8 (110)	2	1865779	1966	40	2	2874704	1970
3.6	1	5404657	1980-81	9.8 (110)	2	2098352	1967	40	2	3043031	1971
3.6	1	5910968	1982	9.8 (110)	2	2290663	1968	40	2	3219678	1972
3.9	1	1655013	1964	9.8 (110)	2	2508759	1969	40	2	3474578	1973
3.9	1	1738941	1965	9.8 (110)	2	2798057	1970	40	2	3859435	1974
3.9	1	1865633	1966	9.8 (110)	2	3002814	1971	40	2	4118385	1975
3.9	1	2098037	1967	9.8 (110)	2	3263263	1972	40	2	4362215	1976
3.9	1	2278851	1968	9.8 (110)	2	3482753	1973	40	2	4564002	1977
4	1	2498136	1969	9.8 (110)	2	3795658	1974	40	2	4860103	1978
4	1	2771662	1970	9.8 (110)	2	4079675	1975	40	2	5174089	1979
4	1	3028361	1971	9.8 (110)	2	4304785	1976	40	2	5556230	1980-81
4	1	3296137	1972	9.8 (110)	2	4605112	1977	40	2	5991215	1982
4	1	3529446	1973	9.8 (110)	2	4839254	1978	40	2	6228285	1983
4	1	3764825	1974	9.9	2	A918999	1986	40	4	C159200	1989
4	2	5589202	1980-81	9.9	2	B114231	1987	40	4	C221500	1990
4	2	9075839	1976	9.9	2	B233200	1988	40 350	2	1356948	1961
4	2	9172806	1978	9.9	2	B385500	1989	45	4	1476510	1962
4	1	A818721	1988	9.9	2	C221500	1990	45	4	A914859	1986
4	1	A837101	1989	10	2	1290910	1960	45	4	B110789	1987
4	1	A855097	1990	15	2	1288910	1960	45	4	B238644	1988
4	1	A906702	1986	15	2	1346448	1961	45	4	B393190	1989
4	1	B114109	1987	15	2	B293117	1988	45 (400)	4	1279685	1960
4.5	1	4108120	1975	15	2	B385500	1989	45 (400)	4	1384806	1961
4.5	1	4377557	1976	15	2	C221500	1990	50	4	1421113	1961
4.5	1	4597262	1977	18	2	5860332	1980-81	50	4	1477910	1962
4.5	1	4869518	1978	18	2	5954911	1982	50	4	1552535	1963
4.5	1	5270784	1979	18	2	6171607	1983	50	4	1605952	1964
4.5	1	5595532	1980-81	18	2	6443973	1984	50	4	1755549	1965
4.5	1	6025119	1982	18	2	6617631	1985	50	4	1870389	1966
4.5	1	6232381	1983	20	2	1558310	1963	50	4	2097445	1967
4.5	1	6428076	1984	20	2	1606903	1964	50	4	2305101	1968
4.5	1	6608536	1985	20	2	1755849	1965	50	4	2514919	1969
5	1	A819951	1988	20	2	1866496	1966	50	4	2736807	1970
5	1	A837101	1989	20	2	1997990	1967	50	4	3009934	1971
5	1	A855097	1990	20	2	2296267	1968	50	4	3235063	1972
6	2	1408611	1961	20	2	2550065	1969	50	4	3478003	1973
6	2	1485612	1962	20	2	2827677	1970	50	4	3816308	1974
6	2	1551443	1963	20	2	2991679	1971	50	4	4141450	1975
6	2	1607513	1964	20	2	3226958	1972	50	4	4357650	1976
6	2	1745521	1965	20	2	3537531	1973	50	4	4576237	1977
6	2	1958278	1966	20	2	3755885	1974	50	4	4962056	1978
6	2	2096171	1967	20	2	4103290	1975	50	4	5193259	1979
6	2	2284857	1968	20	2	4293920	1976	50	4	5531630	1980-81
6	2	A910596	1986	20	2	4580036	1977	50	4	5949386	1982
6	2	B114231	1987	20	2	4819249	1978	50	4	6275323	1983
6	2	B233200	1988	20	2	5183393	1979	50	4	6448808	1984
6	2	B385500	1989	20	2	5606492	1980-81	50	4	6586624	1985
7.5	2	2529895	1969	20	2	A910971	1986	50	3	A912478	1986
7.5	2	2810637	1970	20	2	B114231	1987	50	3	B110789	1987
7.5	2	3016581	1971	20	2	B238464	1988	50	3	B239242	1988
7.5	2	3274633	1972	20	2	B385500	1989	50	3	B396036	1989
7.5	2	3488153	1973	20	2	C221500	1990	50	3	C221500	1990
7.5	2	3801458	1974	22 (200)	2	1292910	1960	60	3	1303411	1960
7.5	2	4087015	1975	22 (200)	2	1339948	1961	60	3	6428681	1984
7.5	2	4314385	1976	25	2	1467499	1962	60	3	6609651	1985
7.5	2	4691222	1977	25	2	5705532	1980-81	60	3	A197392	1986
7.5	2	4851693	1978	25	2	5942041	1982	60	3	B110789	1987
7.5	2	5226935	1979	25	2	6185159	1983	60	3	B239242	1988
7.5	2	5524660	1980-81	25	2	6453343	1984	60	3	B396036	1989
7.5	2	5936301	1982	25	2	6593849	1985	60	3	C221500	1990
7.5	2	6239857	1983	25	2	A911346	1986	65	4	1542745	1963
7.5	2	6430041	1984	25	2	B114231	1987	65	4	1606282	1964
7.5	2	6611886	1985	25	2	B238464	1988	65	4	1765044	1965
8	2	A197112	1986	25	2	B385500	1989	65	4	1869564	1966
8	2	B114231	1987	25	2	C221500	1990	65	4	2119749	1967
8	2	B233200	1988	35	4	1570507	1963	65	4	2309311	1968
8	2	B385500	1989	35	2	1628795	1964	65	4	2503991	1969

MERCURY OUTBOARD

HP	CYL	BEG. S/N	YEAR	HP	CYL	BEG. S/N	YEAR	HP	CYL	BEG. S/N	YEAR
65	4	2803562	1970	90	3	B110054	1987	150	6	3752620	1974
65	4	2997339	1971	90	3	B240451	1988	150	6	4125985	1975
65	3	3293184	1972	90	3	C100000	1989	150XS	6	4319880	1976
65	3	3547987	1973	90	3	C221500	1990	150XS	6	4602012	1977
65	3	3807833	1974	90cc	2	A907702	1986	150XS	6	4868648	1978
65	3	4136685	1975	90cc	2	B114221	1987	V-150	6	4868998	1978
65	3	4382057	1976	95	6	1869776	1966	V-150	6	5129480	1979
70	3	1296411	1960	95	6	2097280	1967	V-150	6	5503247	1980-81
70	3	1413611	1961	100	6	1503332	1962	V-150	6	5944791	1982
70	3	1503459	1962	100	6	1518384	1963	V-150	6	6220254	1983
70	3	4382057	1976	100	6	1665002	1964	V-150	6	6443213	1984
70	3	4571652	1977	100	6	1755459	1965	V-150	6	6616991	1985
70	3	4825249	1978	100	6	2318586	1968	V-150	6	A904646	1986
70	3	5128280	1979	100	6	2484633	1969	V-150	6	B116662	1987
70	3	5579017	1980-81	100	4	B209468	1988	V-150	6	B242881	1988
70	3	5974683	1982	100	4	C100000	1989	V-150	6	C100861	1989
70	3	6279960	1983	100	4	C221500	1990	V-150	6	C221500	1990
70	3	B110054	1987	102cc	2	A819211	1988	V-150XR2	6	A905191	1986
70	3	B240451	1988	102cc	2	A837101	1989	V-150XR2	6	B289430	1988
70	3	C100000	1989	110	6	1870204	1966	V-150XR4	6	B242885	1988
75	4	6432901	1984	110	6	2097385	1967	V-175	6	4301235	1976
75	4	6613221	1985	115	6	2836019	1970	V-175	6	4563802	1977
75	4	A197882	1986	115	6	3023086	1971	V-175	6	4838074	1978
75	3	C100000	1989	115	6	3270480	1972	V-175	6	5180109	1979
75	3	C221500	1990	115	6	3525441	1973	V-175	6	5488752	1980-81
80	4	1335465	1960	115	6	3761035	1974	V-175	6	6618751	1985
80	4	1398630	1961	115	6	4112635	1975	V-175	6	A918329	1986
80	4	2559001	1969	115	6	4310785	1976	V-175	6	B116662	1987
80	4	2783253	1970	115	6	4567952	1977	V-175	6	B241881	1988
80	4	2986444	1971	115	6	4855153	1978	V-175	6	C100861	1989
80	4	3186263	1972	115	6	5168574	1979	V-175	6	C221500	1990
80	4	4831999	1978	115	6	5600967	1980-81	V-200	6	4839034	1978
80	4	5141097	1979	115	6	6006834	1982	V-200	6	5158929	1979
80	4	5582562	1980-81	115	6	6262961	1983	V-200	6	5464486	1980-81
80	4	5987161	1982	115	6	6440183	1984	V-200	6	6073192	1982
80	4	6232941	1983	115	6	6630171	1985	V-200	6	6203991	1983
80	3	A966142	1987	115	6	A907777	1986	V-200	6	6435503	1984
80	3	B240451	1988	115	6	B117567	1987	V-200	6	6625221	1985
80	3	C100000	1989	115	6	B239242	1988	V-200	6	A913228	1986
85	6	1460999	1963	115	4	C100000	1989	V-200	6	B116662	1987
85	6	1648888	1964	115	4	C221500	1990	V-200	6	B241881	1988
85	4	3493913	1973	125	6	2314956	1968	V-200	6	C100861	1989
85	4	3865695	1974	125	6	2536210	1969	V-200	6	C221500	1990
85	4	4092965	1975	135	6	2839369	1970	210cc	2	A918999	1986
85	4	4590512	1977	135	6	3036066	1971	210cc	2	B114231	1987
85XS	4	4366802	1976	V-135	6	A909997	1986	210cc	2	B233405	1988
90	6	1755444	1965	V-135	6	B116662	1987	210cc	2	B385500	1989
90	6	4854301	1978	V-135	6	B241881	1988	V-220	6	B241881	1988
90	6	5160324	1979	V-135	6	C100861	1989	V-225	6	5615282	1980-81
90	6	5594657	1980-81	V-135	6	C221500	1990	V-250	6	C139860	1989
90	6	5996390	1982	140	6	3293234	1972	V-250	6	C221500	1990
90	6	6246856	1983	140	6	4865678	1978	V-275	6	C139860	1989
90	6	6436123	1984	140	6	5189788	1979	V-275	6	C221500	1990
90	6	6623151	1985	140	6	5625108	1980-81	V-300	6	5611648	1980-81
90	6	A902436	1986	150	6	3502806	1973	V-300	6	6239853	1983



18-5007
TUNE-UP KIT

—CONTENTS—

Part #	O.E. #	Description
18-5153	398-174	Contact Set
18-5206	398-693	Condenser



18-5012
TUNE-UP KIT

—CONTENTS—

Part #	O.E. #	Description
18-5148	394-1100A3	Contact Set
18-5169	394-1130A1	Condenser



18-5139
CONTACT SET

Replaces: 336-4318A2, 336-4318A4, 336-4318A3, 336-3948A3, 336-3948A2
(2) 18-5139 = (1) 336-4318A2







HP	Model	Beginning Serial No	Ending Serial No	Contact Set	Condenser	Tune-Up Kit
3.9		1655013	2498155	18-5140	18-5212	18-5008
4		2498136	2693114	18-5140	18-5212	18-5008
4	Ⓢ	2771622	A809600	18-5139	—	—
4.5		4107220	& UP	18-5139	—	—
6		1610265	2529894	18-5140	18-5212	18-5008
7.5	Ⓢ	214324	& UP	18-5153	18-5207	—
7.5		2529895	2721150	18-5140	18-5212	18-5008
7.5		3274633	3801457	18-5139	—	—
9.8		1470349	1865778	18-5153	18-5206	18-5007
9.8		1865776	2708898	18-5140	18-5212	18-5008
9.8		2798057	3263262	18-5139	—	—
9.8		3263263	3795657	18-5139	—	—
10		1120828	112327	18-5153	18-5206	18-5007
10		595628	112327	18-5153	18-5206	18-5007
10		595628	& UP	18-5153	18-5206	18-5007
15		1200114	1499331	18-5153	18-5206	18-5007
20		860979	& UP	18-5153	18-5206	18-5007
20		2827677	3226957	18-5139	—	—
20		3226958	3537530	18-5139	—	—
22		1158546	1499331	18-5153	18-5206	18-5007
25 KF9		377150	379008	18-5148	18-5169	18-5012
25 KG9		377150	379008	18-5148	18-5169	18-5012
25 MARK40		377150	379008	18-5148	18-5169	18-5012
35	350	1271884	1448139	18-5148	18-5169	18-5012
35		1571114	2874703	18-5140	18-5212	18-5008
40		831021	1279684	18-5148	18-5169	18-5012
45		1139538	& UP	18-5148	18-5169	18-5012
30	MK 30 55			—	18-5169	—
30		1271884	1448139	—	18-5169	—
35	35A	1271884	1448139	—	18-5169	—
40		1279685	1476509	—	18-5169	—
45		1476510	1531958	—	18-5169	—
50		1421113	2305100	—	18-5169	—
50		1770179	2116317	—	18-5169	—
50	Ⓢ	2116318	2305100	—	18-5169	—
65 (4CYL)		1542745	2309310	—	18-5169	—

Ⓢ Phelon Magneto only Ⓢ Manual start only Ⓢ Except "Gnat"

 <p>18-5187 IGNITION COIL Replaces: 339-856991A1, 339-850227 For: Mariner 200DFI, 225DFI, V135DFI (2.5L), V150DFI (2.5L) and Mercury 3.0DFI</p>	 <p>18-5181 IGNITION COIL Replaces: 802371A1</p> <p>① 18-5181D Display Package</p>	 <p>18-5186 IGNITION COIL Replaces: 339-7370A13, 339-832757A4</p> <p>① 18-5186D Display Package</p>	
 <p>18-5158 IGNITION COIL Replaces: 8M0077471, 879984T01, 879984A1, 879984T00 For: 40-60 EFI 4 Cylinder (OT409000-1C453839) USA (OP153500-1C453839) Belgium, 30-40 EFI 3 Cylinder (OT409000-1B226999) USA (OP153500-0P400999) Belgium, 30-40 EFI 3 Cylinder (1C000001-Up), 75-115 DFI 3 Cylinder (OT980000-Up), 80 JET 3 Cylinder (1B586067-Up), 200-225 DFI 3.0L (1B504989-1B912785), 200 Pro XS DFI 3.0L (1B504989-1B912785), 250 DFI 3.0L (1B528615-Up), 115 Pro XS 3 Cylinder (1B751825-Up), 125 DFI 3 Cylinder (1B736885-Up), 240 EFI SportJet (0E406400-Up), 600 SCi (0M952908-0M962885), 662 SCi (0M956580-Up), 700 SCi (0M962886-Up), 850 SCi (0M952900-Up), 1025 SCi (0M962886-Up), 1075 SCi (0M957032-Up), 1200 SCi (0M956534-Up)</p>	 <p>18-5159 IGNITION COIL Replaces: 339-8M0077473, 339-883778A02, 339-883778A01 For: 1650 (0M965309-Up), 1550 (0M973231-Up), 1100 (0M965965-Up), 1350 (0M965309-Up), 110 Jet (2.5L) (1B690542-Up), 150 Pro XS (2.5L) (1B690542-Up), 200 (DFI) 3.0L (1B504989-Up), 200 (3.0L-DFI)(DTS) (1B504989-Up), 200 Pro XS (DFI) 3.0L (1B504989-Up), 225 (DFI) 3.0L (1B504989-Up), 225 (3.0L-DFI)(DTS) (1B504989-Up), 250 (DFI) 3.0L (1B528615-Up), V-135 (DFI) 2.5L (1B417702-Up), V-150 (DFI) 2.5L (1B417702-Up), V-175 (DFI) 2.5L (1B417702-Up), 2.5XS (2.5L DFI) (0T997974-1E000796)</p>		
 <p>18-5433 IGNITION COIL Replaces: 32193A2, 38547, 392-806529A1, 898253T24 (Uses External Resistor)</p>	 <p>18-5182 IGNITION COIL Replaces: 823033 For: 2.5/3/3.3 HP</p>	 <p>18-23205 IGNITION COIL Replaces: 339-859738T1 Fits: Mercury 25 4-Stroke(G590000-P016999), 40 4-Stroke 4 cyl(T178500-T598999), 50 4-Stroke 4cyl(T178500-T598999), 60 4-Stroke 4cyl(T178500-T598999)</p> <p>Display Package</p>	 <p>18-25400 PULSER COIL Replaces: 16066004 Fits: Mercury 8/9.9 4-Stroke(R042475 & Up)</p>
 <p>18-5513 COIL, CHARGE Replaces: 803844T01 Fits: Mercury 8/9.9 4-Stroke(R042475 & Up)</p>	<p>new</p> <p>18-5154 PENCIL COIL Replaces: 339-880615T01 Fits: 350SCi Verado (1B716557-2B143542), 200-275 Verado (6 Cyl) (0T980000-2B578935), 300 Verado (OP520553-2B578935), 200 Pro Verado (6 Cyl) (2B034840-2B577715), 250-300 Pro Verado (1B830170-2B577715), 75-115 EFI (1B366823-2B094995), 135-175 Verado (1B227000-2B576734), 200 Verado (4 Cyl) (1B517159-2B578935), 350 Verado (2B141617 & Up), 350 Pro Verado (2B141124 & Up), 400 Verado (2B141124 & Up)</p>	 <p>18-5775 SWITCH BOX Replaces: 332-7778A6, 332-7778A9, 332-7778A12, 332-7778A7, 332-7778A3, 332-7778A1, 332-5524A1, F7778A9, F749301</p>	
 <p>18-5776 SWITCH BOX Replaces: 339-7452A3, 339-7452A2, 339-7452A1</p>	 <p>18-5777 SWITCH BOX Replaces: 339-7452A15, 339-7452A19, 339-7452A9, 339-7452A7</p>	 <p>18-5778 SWITCH BOX Replaces: 339-7452A14, 339-7452A21, 339-7452A11, 339-7452A8</p>	 <p>18-5787 SWITCH BOX ASSEMBLY Replaces: 332-4911A8 For: 40 HP</p>

① Items ending in "D" are Display Packaged - Regular number is Non-Display

 <p>18-5788 SWITCH BOX ASSEMBLY Replaces: 339-6222A8 For: 4 HP</p>	 <p>18-5790 SWITCH BOX ASSEMBLY Replaces: 18495A26, 18495A19, 18495A12 For: 75-90 HP</p>	 <p>18-5791 SWITCH BOX ASSEMBLY Replaces: 19052A8, 19052A5, 19052A3 For: 50-60 HP</p>	 <p>18-5792 SWITCH BOX ASSEMBLY Replaces: 16061T For: 4/5 HP</p>
 <p>18-5793 SWITCH BOX ASSEMBLY Replaces: 823034, 823034T For: 2.5/3.3 HP</p>	 <p>18-5881 SWITCH BOX Replaces: 332-5772A7, 332-5772A5, 332-5772A3, 332-5772A2, 332-5772A1, F720301</p>	 <p>18-1151 DISTRIBUTOR Replaces: 30-20066 SKF France R822T</p>	 <p>18-1152 DISTRIBUTOR Replaces: 30-26379 SKF France 6002-2 RSI/HT</p>

4-STROKE ENGINES

HP	Model	Beginning Serial No	Ending Serial No	Coil	Switch Box
30EFI (3 Cyl.)	USA	0T409000	1B226999	18-5158	N/A
30EFI (3 Cyl.)	Belgium	0P153500	0P400999	18-5158	N/A
30EFI (3 Cyl.)	Belgium	1C000001	& Up	18-5158	N/A
40EFI (3 Cyl.)	USA	0T409000	1B226999	18-5158	N/A
40EFI (3 Cyl.)	Belgium	0P153500	0P400999	18-5158	N/A
40EFI (3 Cyl.)	Belgium	1C000001	& Up	18-5158	N/A
40EFI (4 Cyl.)	USA	0T409000	1C453839	18-5158	N/A
40EFI (4 Cyl.)	Belgium	0P153500	1C453839	18-5158	N/A
50EFI (4 Cyl.)	USA	0T409000	1C453839	18-5158	N/A
50EFI (4 Cyl.)	Belgium	0P153500	1C453839	18-5158	N/A
60EFI (4 Cyl.)	USA	0T409000	1C453839	18-5158	N/A
60EFI (4 Cyl.)	Belgium	0P153500	1C453839	18-5158	N/A
75EFI (4 Cyl.)	USA	1B366823	2B094995	18-5154	N/A
90EFI (4 Cyl.)	USA	1B366823	2B094995	18-5154	N/A
115EFI (4 Cyl.)	USA	1B366823	2B094995	18-5154	N/A
135 Verado (4 Cyl.)	USA	1B227000	2B576734	18-5154	N/A
150 Verado (4 Cyl.)	USA	1B227000	2B576734	18-5154	N/A
175 Verado (4 Cyl.)	USA	1B227000	2B576734	18-5154	N/A
200 Verado (4 Cyl.)	USA	1B517159	2B578935	18-5154	N/A
200 Verado (6 Cyl.)	USA	0T980000	2B578935	18-5154	N/A
200 Pro Verado (6 Cyl.)	USA	2B034840	2B577715	18-5154	N/A
225 Verado (6 Cyl.)	USA	0T980000	2B578935	18-5154	N/A
250 Verado (6 Cyl.)	USA	0T980000	2B578935	18-5154	N/A
250 Pro Verado	USA	1B830170	2B577715	18-5154	N/A
275 Verado (6 Cyl.)	USA	0T980000	2B578935	18-5154	N/A
275 Pro Verado	USA	1B830170	2B577715	18-5154	N/A
300 Verado	USA	0P520553	2B578935	18-5154	N/A
300 Pro Verado	USA	1B830170	2B577715	18-5154	N/A
350 Verado	USA	2B141617	& Up	18-5154	N/A
350SCi Verado	USA	1B716557	2B143542	18-5154	N/A
350 Pro Verado	USA	2B141124	& Up	18-5154	N/A
400 Verado	USA	2B141124	& Up	18-5154	N/A

① Two Required ② Three Required ③ Four Required ④ Six Required

2-STROKE ENGINES

HP	Model	Beginning Serial No	Ending Serial No	Coil	Switch Box
4 (2 cyl.prod. of USA)		5589202	& UP	—	18-5788
4		G710613	& UP	—	18-5792
6		A197112	G760299	18-5186 ①	18-5777
6		G760300	T800749	18-5186	—
8		A197112	G760299	18-5186 ①	18-5777
8		A760300	& UP	18-5186	18-5777
210CC	Sail Power	A918999	& UP	18-5186 ①	18-5777
9.9		A197112	G760299	18-5186 ①	18-5777
9.9		G760300	& UP	18-5186	18-5777
10		D038000	G760299	—	18-5777
15		B292414	G760299	18-5186 ①	18-5777
15		G760300	& UP	18-5186	18-5777
15	Sea-Pro	G044027	G437999	18-5186	—
15		G438000	G760299	18-5186	18-5777
15		G760300	& UP	18-5186	—
15	Comm.	G760300	& UP	18-5186	—
15	Non-Comm.	G760300	& UP	18-5186	—
15XD	Comm	G760300	& UP	18-5186	—
15XD	Non-Comm.	760300	& UP	18-5186	—
18		5837437	6443972	18-5186 ①	18-5776
18		6443973	& UP	18-5186 ①	—
18 BULLET	Comm.	6443973	&UP	18-5186	—
20		3537531	3755884	18-5186	—
20		6443973	G044026	18-5186 ①	18-5777
20		G044027	G437999	18-5186	—
20		G438000	G760299	18-5186 ①	18 -5777
20	Comm.	G760300	T800999	18-5186	—
20 NON	Comm.	G760300	T800999	18-5186	—
20 JET		G044027	G760299	18-5186	—
20 JET		G760300	& UP	18-5186	—
25		5705532	6443972	18-5186 ①	18-5776
25	Uses Nut Connection	6443973	& UP	18-5186 ①	18-5776
25	Uses Bullet Connection	6443973	& UP	18-5186	18-5777
25		B238464	G044026	18-5186 ①	18-5777
25		G04027	G437999	18-5186	—
25		G438000	G760299	18-5186	—
25	Comm	G760300	& UP	18-5186	—
25	Non-Comm.	G760300	& UP	18-5186	—
30	Jet	C159200	G589999	18-5186 ①	18-5881
35	Uses Nut Connection	6445653	B110788	18-5186 ①	18-5776
35	Uses Bullet Connection	6445653	B110788	18-5186 ①	18-5778
35		B110789	& UP	18-5186	18-5778
40		3336258	3859434	18-5186	—
40 (2 cyl.)		3859435	5823917	18-5186	—
40 (2 cyl.)		5823918	6443973	18-5186 ①	18-5776
40 (4 Cyl.)		C159200	& UP	18-5186 ③	18-5881
45/50 (4 Cyl.)		5531630	& UP	18-5186 ③	18-5881
45 (3 Cyl.)	Jet	G290584	G589999	18-5186	—
50 (4 Cyl.)		5193259	5531629	18-5186	18-5881
50 (4 Cyl.)		5531630	& UP	18-5186	18-5881
50/60 (3 Cyl.)		6428681	D000749	18-5186 ②	18-5775
50/55/60 (3 Cyl.)		D000750	G589999	18-5186 ②	18-5791
55 (3 Cyl.)		D000750	G589999	18-5186	—
60 (3 Cyl.)		6428681	D000749	18-5186	18-5775
60 (3 Cyl.)		D000750	G589999	18-5186	—

① Two Required ② Three Required ③ Four Required ④ Six Required

2-STROKE ENGINES (CONT.)					
HP	Model	Beginning Serial No	Ending Serial No	Coil	Switch Box
65 (3 Cyl.)		4382057	4571651	—	18-5775
65 jet		D283222	G437999	18-5186	—
70	MK75,78	1110600	& UP	18-5433	N/A
70 (6 Cyl.)		1296411	1566239	18-5433	N/A
Mercury 70		4571652	5128279	—	18-5775
Mariner70		5128280	& UP	18-5186 ②	18-5775
70		1296411	1566239	18-5433 ①	N/A
70		5579016	6428680	18-5186 ②	18-5775
70/75 (3 Cyl.)		C272000	D283221	18-5186 ②	18-5775
75 (3 cyl)		D283222	G437999	18-5186 ③	18-5790
75 (4 Cyl.)		6432901	& UP	18-5186 ③	18-5881
75 (3 Cyl.)		C222000	D283221	18-5186 ②	18-5775
75 (3 Cyl.)		D283222	G437999	18-5186 ②	18-5790
75DFI (3 Cyl.)		0T980000	& Up	18-5158	N/A
800 (6 Cyl.)		1335465	1566239	18-5433 ①	N/A
Mariner 80 (4 Cyl.)		5144547	& UP	18-5186 ③	—
Merc 80 (4 Cyl.)		5582562	6432900	18-5186 ③	—
80 (4 Cyl.)		4831999	5141096	—	18-5881
80 (4 Cyl.)		5141097	6432900	18-5186	18-5881
80 (3 Cyl.)		A996142	& UP	18-5186 ②	18-5775
80 Jet		D283222	G437999	—	18-5881
80 Jet (3 Cyl.)		1B586067	& Up	18-5158	N/A
85 (6 Cyl.)		1460999	1766823	18-5433 ①	N/A
85 (4 Cyl.)		4366802	4831998	—	18-5881
90		1766824	1869775	18-5433 ①	N/A
90 (6 cyl.)		5299506	& UP	18-5186 ④	18-5775 ①
90 (3 Cyl.)		A996142	D283221	18-5186 ②	18-5775
90 (3 Cyl.)		D283222	G437999	18-5186	18-5790
90 (Powerhead)	Sport Jet	E023150	E095087	—	18-5775
90DFI (3 Cyl.)		0T980000	& Up	18-5158	N/A
95		1869776	1935100	18-5433 ①	N/A
100 (6 cyl.)		1464949	2318585	18-5433 ①	N/A
100 (4 Cyl.)		B209468	G437999	18-5186 ③	18-5881
105 Jet		D082000	G303045	18-5186 ④	18-5775 ①
110		1870204	2314955	18-5433 ①	N/A
110 Jet	2.5L		1B490865	18-5187	N/A
110 Jet	2.5L	1B690542	& Up	18-5158	N/A
115 (6 Cyl.)		5314656	& Up	18-5186 ④	18-5775 ①
115 (6 Cyl.)		5314656	& Up	18-5186	—
115 (4 Cyl.)		B209468	6437999	18-5186 ③	—
115 (3 Cyl.)		C100000	G437999	—	18-5881 ①
115 DFI (3 Cyl.)		0T980000	& Up	18-5158	N/A
115 Pro XS (3 Cyl.)		1B751825	& Up	18-5158	N/A
125 (4 Cyl.)		D283222	G437999	18-5186	18-5881 ①
125 DFI (3 Cyl.)		1B736885	& Up	18-5158	N/A
V-135		A904646	G960499	18-5186 ④	18-5775 ①
V-135 DFI	2.5L	G590000	1B417701	18-5187	N/A
V-135 DFI	2.5L	1B417702	& Up	18-5158	N/A
140		5327663	& Up	18-5186 ④	18-5775 ①
140 Jet		D082000	G960499	18-5186 ④	18-5775 ①
150		A904646	G960499	18-5186	18-5775
V-150	Orange Coil	4868998	A904645	—	18-5775 ①
V-150	Blue Coil	4868998	A904645	18-5186	18-5775 ①
V-150		5129480	G960499	18-5186 ④	18-5775 ①
V-150 XR2		6616991	A904645	18-5186 ④	18-5775 ①

① Two Required ② Three Required ③ Four Required ④ Six Required

2-STROKE ENGINES (CONT.)

HP	Model	Beginning Serial No	Ending Serial No	Coil	Switch Box
V-150 XR4		B242885	D819999	18-5186 ④	18-5775 ①
V-150 DFI	2.5L	G590000	1B417701	18-5187	N/A
V-150 DFI	2.5L	1B417702	& Up	18-5158	N/A
150 Pro XS	2.5L	1B690542	& Up	18-5158	N/A
V-175		4301235	5180108	—	18-5775 ①
V-175,EFI, XR1		5180109	G960499	18-5186 ④	18-5775 ①
V-175 EFI		D000750	G960499	18-5186	—
V-175 DFI	2.5L	T178500	1B417701	18-5187	N/A
V-175 DFI	2.5L	1B417702	& Up	18-5158	N/A
V-200, XR1		5363918	G960499	18-5186 ④	18-5775 ①
V-200 EFI		C100861	G960499	18-5186	—
V-200 DFI		G590000	1B504988	18-5187	—
200 DFI		G960500	T800999	18-5187	N/A
200 DFI	3.0L	T801000	1B504988	18-5187	N/A
200 DFI	3.0L	1B504989	1B912785	18-5158	N/A
200 DFI (DTS)	3.0L	T980000	1B504988	18-5187	N/A
200 DFI (DTS)	3.0L	1B504989	& Up	18-5158	N/A
200XS DFI	2.5L	T235000	1E002110	18-5187	N/A
200 Pro XS	3.0L	1B504989	& Up	18-5158	N/A
200 Sport XS	3.0L	1E000797	1E002583	18-5187	N/A
V-220		B117316	& Up	18-5186 ④	18-5775 ①
V-225	2.4L	5628028	& Up	18-5186 ④	18-5775 ①
V-225 DFI		G590000	B504988	18-5187	—
V-225 PRO XS		B104549	B426650	18-5187	—
225 DFI	3.0L	G590000	1B504988	18-5187	N/A
225 DFI	3.0L	1B504989	1B912785	18-5158	N/A
225 DFI (DTS)	3.0L	T980000	1B504988	18-5187	N/A
225 DFI (DTS)	3.0L	1B504989	& Up	18-5158	N/A
240 EFI SportJet		E406400	& Up	18-5158	N/A
V-250	3.4L	C101891	& Up	18-5186	—
250XS	3.0L	T651945	1E002341	18-5187	N/A
250 DFI	3.0L	1B528615	& Up	18-5158	N/A
V-275	3.4L	C101891	& Up	18-5186	—
V-300	3.4L	5611648	& Up	18-5186	—

① Two Required ② Three Required ③ Four Required ④ Six Required

PREMIUM MARINE SPARK PLUG WIRE LEADS

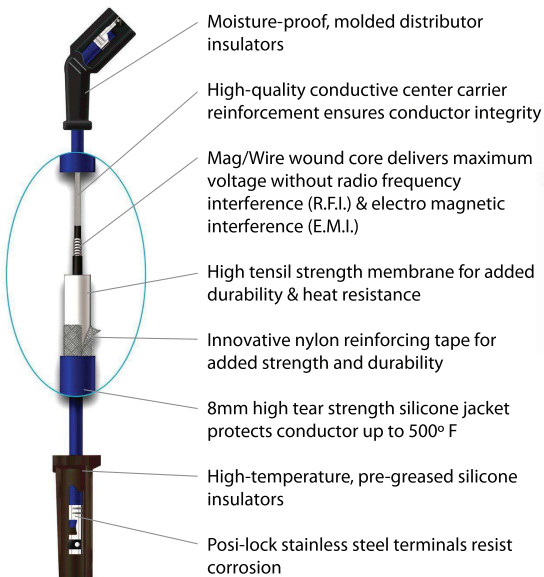



















Sierra's MAGFORCE Ignition Wires are "Electronics Friendly" protecting all of your electronic devices and electronic engine controls from RFI and EMI while delivering the maximum amount of voltage. Exact fit design ensures easy installation and years of trouble - free service.



Part #	OEM #	Description
18-8819-1	—	7" Spark Plug Wire (8mm)
18-5228-1	—	9" Spark Plug Wire (8mm)
18-5228-1D③	84-813715A1	9" Spark Plug Wire (8mm)
★ 18-5227-1	—	9" Spark Plug Wire (7mm)
18-5227-1D②③	84-813715A1	9" Spark Plug Wire (7mm)
18-5229-9-1①②	—	22" Spark Plug Wire (7mm)
18-5230-9-1①②	—	10" Spark Plug Wire (7mm)

★ Metallic core wire ① PKG. OF 5 ② 7mm copper core wire
 ③ Items ending in "D" are Display Packaged - Regular number is Non-Display

 <p>18-5225 SPARK PLUG WIRE KIT Replaces: 84-99215A26, 84-813706A26, 84-93475A26, 84-93212A1, 84-90816A26 Kit includes 25 ft. Roll of 7 MM Hypalon Ignition Wire With a Metallic Core and a Large Assortment of Three Different End Fittings to Fit Outboard Motors.</p>	 <p>18-5226 IGNITION WIRE Metallic Core 100' Spool 7mm Hypalon</p>	<p>PKG. OF 10</p>  <p>18-5224 18-5224-9Ⓢ SPARK PLUG WIRE TERMINAL Replaces: 20121, 8M0084600</p>	
<p>PKG. OF 10</p>  <p>18-5750 18-5750-9Ⓢ UNIVERSAL SPARK PLUG BOOTS Supplied complete w/Terminal Connector</p>	 <p>18-5752 UNIVERSAL SPARK PLUG BOOT 8mm</p>	 <p>18-28080 WIRE SET Replaces: 84-821945A56 Fits: 225(3.0L Carb) and 225/250(3.0L EFI) (G303045 & Below)</p>	
 <p>18-28081 WIRE SET Replaces: 84-813706A56 Fits: 225(3.0L Carb) and 225/250(3.0L EFI) w/CDM Modules (G303045 & Up)</p>	 <p>18-28082 WIRE SET Replaces: 84-813715A8 Fits: 100, 115, 125 & 80 Jet(4 cyl) (0G301750 & Below)</p>	 <p>18-28083 PLUG WIRE Replaces: 84-881908T (1 WIRE) Fits: Mercury V6 EFI/DFI/DTS</p>	 <p>18-28084 PLUG WIRE SET Replaces: 84-881908T (3 WIRES) Fits: Mercury 30-40 EFI 4-stroke(3 cyl)</p>
 <p>18-28085 PLUG WIRE SET Replaces: 84-881908T (4 WIRES) Fits: Mercury 40-6- EFI 4-stroke (4cyl)</p>	 <p>18-28086 PLUG WIRE SET Replaces: 84-881908T (6 WIRES) Fits: Mercury V6 EFI/DFI/DTS</p>	 <p>MP41000 IGNITION SWITCH Push to Choke — 3 Position — 6 Terminal Replaces: 87-88107, 87-88107A5 See ELECTRICAL PRODUCTS - Ignition Switches section for wiring diagram.</p>	 <p>MP41070-2 IGNITION SWITCH Push to Choke — 3 Position — 6 Wire Sealed Polyester Replaces: 87-17009A2</p>
 <p>MP51090 (Display Pkg.) MP51092 IGNITION SWITCH 3 Position Magneto — OFF- RUN- START PUSH to Choke Replaces: 87-17009A5</p>	 <p>MP52000 (Display Pkg.) MP52002 IGNITION SWITCH 3 Position Magneto — OFF- RUN- START PUSH to Choke — 8 Wire Replaces: 87-88107A5</p>	 <p>18-6751 MANUAL RELEASE VALVE Replaces: 893929A01, 813442A2, 813442A1, 811618A1, 811618, 812843A1, 99660A1 Fits: Most 2 & 4 Stroke Outboards with Integral tilt and trim</p>	 <p>18-6771 TILT/TRIM RESERVOIR Replaces: 18525A1</p>

Ⓢ Priced per package



18-6778
TILT/TRIM RESERVOIR
 Replaces: 883166A1, 883166A2
 For: Motors with 4 screw attachments

(2 Wire w/ Relays)



18-6273-1
TILT/TRIM MOTOR
 High Performance Cartridge Pump
 w/Replaceable Motor
 Replaces: 99186, 99186-1, 99186-T
 Fits: 35-220 HP (1985-93) Mercury/Mariner Outboards
 w/ Design I, 3 Ram, 3 Wire Tilt/Trim Units w/ Side Fill Reservoir. Integral Trim/Tilt System
 Uses relay **18-5737**



18-6757
TILT/TRIM MOTOR
 Fits: Mercury 35-220 HP (1985-92) w/ Design I, 3-Ram Side Fill Integral Trim/Tilt System w/ Square Style Eaton Motor and **18-6273-1** Tilt/Trim Motor Pump Assy
 Uses wire harness **18-6823**



18-6763
TILT/TRIM MOTOR
 Replaces: 92975A28, A32
 To 1984 for Most Mercury Outboards
(Motor and Reservoir Only)



18-6765
TILT/TRIM ASSEMBLY
 Replaces: 823653A5, 92459A4, 823653A9
 Fits: 250,275 HP & V-3.4L,
 Serial No.5611648-UP
(Motor Only)
 Replaces: 17649A02



18-6773
TRIM MOTOR
 Replaces: 828708, 878265A4
 For most late model Mercury/Mariner 1996 & UP (135,150, XR6 Mag III, 175, 200, 225, 250 HP — 105 - 140 HP Jet)



18-6774
TRIM MOTOR
 Replaces: 811628, 828708A1, 878265A6
 High-performance cartridge, replaceable motor. Design II,
 Ram 3, 2 wire, tilt/trim units. Squared style Eaton
 Uses wire harness **18-6823**

18-6775
TILT/TRIM MOTOR
 Reference OE reservoir 811673 1
 Contains: All parts necessary, a new 3-wire motor/reservoir, drive shaft coupler, oil seal, O-ring and hardware.
 Yellow fill plug.
 For:

Models	Models
65 Jet	100 4-Cyl.
75 3-Cyl.	115 4-Cyl.
80 Jet	125 4-Cyl.
90 3-Cyl.	

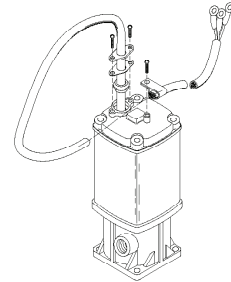

If you have this 3-wire single ram system, use **18-6775**

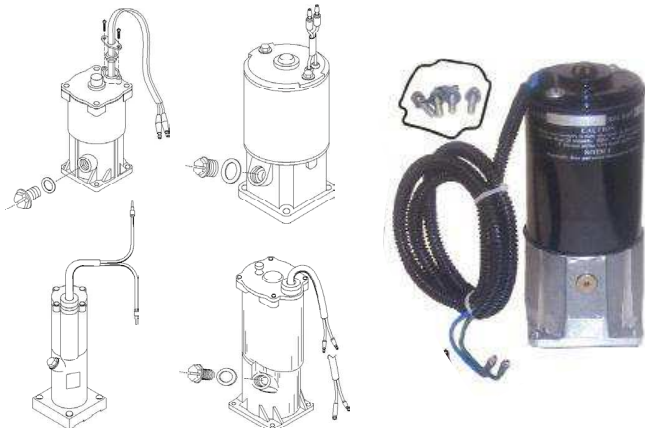

If you have any of the 2-wire single systems, use **18-6777**

18-6777
TILT/TRIM MOTOR
 Replaces: 818903A1, 819762A4-A7, 819479A1, 819480A1, 81977A8-A9, 822870A1, 830250A3-T3, 832021A1-T4-A2-T2, 855654A1-T2, 19217A1-A5, 854472A2, A3, A4
 Contains: All parts necessary, a new 2-wire motor/reservoir, drive shaft coupler, oil seal, O-ring and hardware. Yellow fill plug. Square base O-ring.

For:

Models	Models
30 Jet	60 3-Cyl., Bigfoot
30 4-Stroke	65 Jet
35	75 3-Cyl.
40 2, 3, 4-Cyl.	75 4-Stroke
40 4-Stroke, Bigfoot	80 Jet
45 4-Stroke, Bigfoot, Bodensee	90 3-Cyl.
50 3-Cyl.	90 4-Stroke
50 4-Stroke, Bigfoot	100 4-Cyl.
55 3-Cyl.	115 4-Cyl.
	125 4-Cyl.



18-6448
ELECTRIC START CONVERSION KIT
 Fits: Mercury 30 HP



18-6274
TILT/TRIM MOTOR
 Replaces: 14336A20, 865380A13
 Low pressure / high flow

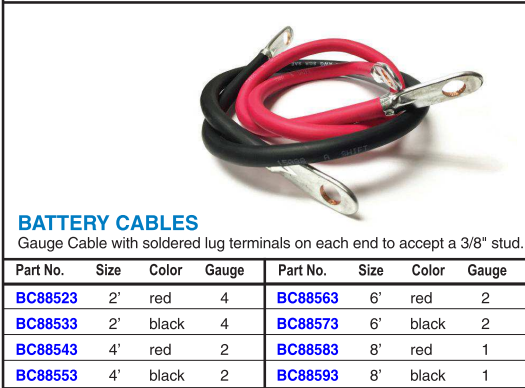

BATTERY CABLES
 Gauge Cable with soldered lug terminals on each end to accept a 3/8" stud.

Part No.	Size	Color	Gauge	Part No.	Size	Color	Gauge
BC88523	2'	red	4	BC88563	6'	red	2
BC88533	2'	black	4	BC88573	6'	black	2
BC88543	4'	red	2	BC88583	8'	red	1
BC88553	4'	black	2	BC88593	8'	black	1



18-9800
COMPRESSION TESTER
 Perfect for hard to reach bottom spark plug holes on older Mercury models.



18-9801
MULTI METER/DVA TESTER
 Replaces: 91-99750A1
 A must for testing Mercury ignition systems.



18-9802
TIMING LIGHT
 Replaces: 91-99379
 Self-powered accurate up to 10,000 RPM's.



18-5864
STATOR
 Replaces: 86617A20
 For: 6-25 HP



18-5865
STATOR
 Replaces: 398-5704A7
 For: 50-70 HP



18-5867
STATOR
 Replaces: 398-9873A4
 For: 135-200 V-6



18-5870
STATOR
 Replaces: 398-832075A4-A21
 For: 30-125 HP
 Replacement for the 18-5873 & 18-5874 kits



18-5871
STATOR
 Replaces: 398-5454A32
 For: 135-300 V6



18-5873
STATOR KIT
 Replaces: 398-832075A6
 For: 100, 115, 125 HP
 Includes 18-5870 stator

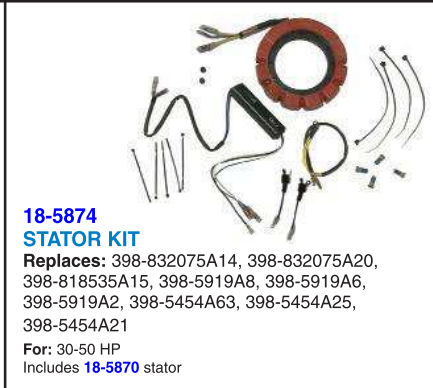

18-5874
STATOR KIT
 Replaces: 398-832075A14, 398-832075A20, 398-818535A15, 398-5919A8, 398-5919A6, 398-5919A2, 398-5454A63, 398-5454A25, 398-5454A21
 For: 30-50 HP
 Includes 18-5870 stator



18-5876
STATOR
 Replaces: 398-9610A19
 For: 135 -200 HP

APPLICATION BEGINS ON NEXT PAGE



18-5866
STATOR
Replaces: 398-5919A4, 76314A3
For: Mercury 45-50 4 cyl.



18-5854
STATOR
Replaces: 398-5454A17
 *Note: Extra black lead goes to engine ground.



18-5855
STATOR
Replaces: 336-3996A7



18-5856
STATOR
Replaces: 398-5255



18-5857
STATOR
Replaces: 398-5454A7



18-5859
STATOR
Replaces: 398-5454A26, 398-5454A22, 398-5919A7, 398-5919A3



18-5860
STATOR
Replaces: 398-5454A35



18-5796
TRIGGER ASSEMBLY
Replaces: 96455A15
For: 6 cyl.



18-5797
TRIGGER ASSEMBLY
Replaces: 96455A8, 96455A1, 68162A6, 68162A3
For: 3 cyl.



18-5798
TRIGGER ASSEMBLY
Replaces: 96455A9, 96455A6, 68162A8, 68162A5, 68162A1
For: 6 cyl.

STATOR & TRIGGER APPLICATIONS

HP	Beg. S/N	End S/N	Trigger	Stator	HP	Beg. S/N	End S/N	Trigger	Stator
6	A197112	G760299	—	18-5864	18XD	6443973	B238463	—	18-5864
7.5	2810637	3274632	—	18-5855	20	2827677	3226957	—	18-5855
8	A197112	G760299	—	18-5864	20	6443973	G044026	—	18-5864
9.8	2798057	3263262	—	18-5855	20, 20 JET	G044027	G437999	—	18-5863
9.9	A197112	G760299	—	18-5864	20, 20 JET	G438000	G760299	—	18-5864
XR10,10 MAG & SEA PRO	D038000	G760299	—	18-5864	20XD	6443973	B238463	—	18-5864
15	A197112	G760299	—	18-5864	25	5705532	6443972	—	18-5864
15 SEA PRO, SUPER 15	G044365	G437999	—	18-5863	25, 25 SEA PRO & MARATHON	B238464	G044026	—	18-5864
15 SEA PRO, SUPER 15	G438000	G760299	—	18-5864	25, 25 SEA PRO & MARATHON	G044027	G437999	—	18-5863
18	5837437	6443972	—	18-5864	25, 25 SEA PRO & MARATHON	G438000	G760299	—	18-5864

APPLICATION CONTINUED ON NEXT PAGE

STATOR & TRIGGER APPLICATIONS

HP	Beg. S/N	End S/N	Trigger	Stator	HP	Beg. S/N	End S/N	Trigger	Stator
25XD	5705532	G044026	—	18-5864	V150	A904646	C100860	18-5798	18-5860 ②
30 2 cyl electric models	G055314	& UP	—	18-5870 **	V150	A904646	C100860	18-5798	18-5871
30 JET 3 cyl electric models	G590000	T408999	—	18-5870 **	V150	C100861	C239552	18-5798	—
30 Jet 4 cyl electric models	C159200	D055047	—	18-5874 **	V150	C239553	D081999	18-5798	18-5860 ③
35 2 cyl	6445653	B110788	—	18-5864	V150	C239553	D081999	18-5798	— †
40 2 cyl	3859435	5823917	—	18-5856 ①	V150	C239553	D081999	18-5798	18-5867 ③⑥
40 2 cyl electric start	G055314	& UP	—	18-5870 **	V150	D082000	G960499	18-5798	18-5876
40 3 cyl electric start	G531301	& UP	—	18-5870 **	V150 EFI	D082000	G960499	18-5798	18-5876
40 3 cyl electric start (Belgium)	9973100	& UP	—	18-5874 **	V150 XRI EFI	D082000	G303045	18-5798	18-5876
40 4 cyl electric start	C159200	D055047	—	18-5874	150 XR-4	B242885	C100860	18-5798	18-5860
40 JET electric start	T178500	& UP	—	18-5874 **	150 XR-4	C100861	C239552	18-5798	—
45 4 cyl manual start only	5531630	B110788	—	18-5866	150 XR-4	C239553	D081999	18-5798	18-5860 ③
45 4 cyl electric models	5531630	& UP	—	18-5870	150 XR-4	C239553	D081999	18-5798	— †
45 JET electric models	G590000	T129554	—	18-5874 **	150 XR-4	C239553	D081999	18-5798	18-5867 ③⑥
50 4 cyl manual start only	4357640	& UP	—	18-5866	150 XR-4, MAG II	C239553	D081999	18-5798	—
50 4 cyl electric models	4357640	& UP	—	18-5870	150 XR-4, MAG II	C239553	D081999	18-5798	18-5867 ③⑥
50 3 cyl	6428681	D000749	18-5797	18-5865	150 XR-6, MAG III	D082000	G960499	18-5798	18-5876
50, 55 3 cyl electric start	G590000	& UP	—	18-5870	V175	4301235	6618750	18-5798	18-5857
50 3 cyl electric models (Belgium)	9973100	& UP	—	18-5870	V175	6618751	C100860	18-5798	18-5871 ④
55 3 cyl electric models	D000750	G589999	—	18-5870	V175	6618751	C100860	18-5798	18-5857 ④
55 3 cyl electric models (Belgium)	9741042	9973088	—	18-5870	V175	6618751	C100860	18-5798	18-5860 ⑤
60 3 cyl	6428681	D000749	18-5797	18-5865	V175	C100861	C239552	18-5798	—
60 3 cyl electric models	G590000	& UP	—	18-5870 **	V175	C239553	D081999	18-5798	18-5860 ③
60 3 cyl electric models (Belgium)	9973100	& UP	—	18-5870 **	V175	C239553	D081999	18-5798	18-5867 ③⑥
60 3 cyl Bigfoot	G590000	G760299	—	18-5874 **	V175	C239553	D081999	18-5798	— †
65 (850) 3 cyl	4382057	4571651	—	18-5865	V175	D082000	G960499	18-5798	18-5876
70 3 cyl	4571652	A996141	18-5797	18-5865	V175 MAG, EFI	D000750	D081999	18-5798	—
75 4 cyl	6432901	& UP	—	18-5859	V175 EFI	D303046	G960499	18-5798	18-5876
75 3 cyl electric models	G438000	& UP	—	18-5870	V175 XRI EFI	D000750	D081999	18-5798	—
80 (80, 800) 4 cyl	4831999	6432900	—	18-5859	V175 XRI EFI	D082000	G303045	18-5798	18-5876
80 JET	G438000	& UP	—	18-5870 **	V200	4839034	6625220	18-5798	18-5857 ④
85 (850) 4 cyl	4366802	4831998	—	18-5859	V200	6618751	C100860	18-5798	18-5860
90 6 cyl	5299506	& UP	18-5798	18-5854	V200	C100861	D081999	18-5798	18-5860 ③
90 3 cyl electric models	G438000	& UP	—	18-5870	V200	C100861	C291519	18-5798	— †
90 3 cyl (Belgium) electric models	9927000	& UP	—	18-5870	V200	C100861	C291519	18-5798	18-5867 ③⑥
100 4 cyl	G438000	& UP	—	18-5870 **	V200	D082000	G960499	18-5798	18-5876
100 4 cyl	9927000	& UP	—	18-5870 **	V200 EFI	C100861	OD081999	18-5798	—
100 4 cyl with voltage reg.	B209468	G437999	—	18-5873 **	V200 EFI	G303046	G960499	18-5798	18-5876
100 4 cyl with voltage reg. (Belgium)	9523024	9926999	—	18-5873 **	V200 XRI EFI	C291520	D081999	18-5798	— †
105 JET	D082000	G960499	18-5798	18-5876	V200 XRI EFI	D082000	G960499	18-5798	18-5876
115 6 cyl	5314656	& UP	18-5798	18-5854	V220	B117316	& UP	—	18-5860
115 4 cyl electric models	G438000	& UP	—	18-5870 **	V225	5628028	& UP	18-5798	18-5857
115 4 cyl electric models (Belgium)	9927000	& UP	—	18-5870 **	SPORTJET MODELS				
115 4 cyl with voltage reg.	C10000	G437999	—	18-5873 **	90	ALL W/RED STATOR		—	18-5870
115 4 cyl with voltage reg. (Belgium)	9559771	9926999	—	18-5873 **	95XR	ALL W/RED STATOR		—	18-5870
125 4 cyl	G438000	& UP	—	18-5870 **	120XR	ALL W/RED STATOR		—	18-5870
125 4 cyl (Belgium)	9927000	& UP	—	18-5870 **	175XR2	ALL		18-5796	—
125 4 cyl with voltage reg.	D283222	G437999	—	18-5873 **	① Electric start models only ② Stators with 5/8" laminations only ③ Applications with 16 amp Stator and non-louvered flywheel cover ④ Applications not using a voltage regulator ⑤ Stators with 5/8" laminations and used with 15 amp voltage regulator ⑥ Flywheel without screws ** May require the purchase of voltage regulator if not currently equipped † Applications with clear 40 amp stator with louvered flywheel cover				
125 4 cyl with voltage reg. (Belgium)	9793577	9926999	—	18-5873 **					
V135	A904646	C100860	18-5798	18-5860 ②					
V135	A904646	C100860	18-5798	18-5871					
V135	C100861	C239552	18-5798	—					
V135	C239553	D081999	18-5798	18-5860 ③					
V135	C239553	D081999	18-5798	—					
V135	C239553	D081999	18-5798	18-5867 ③⑥					
V135	D082000	G960499	18-5798	18-5876					
140	5327663	& UP	18-5798	18-5854					
140 JET	UP TO	G760299	18-5798	18-5876					
V150	4868998	A904645	18-5798	18-5857					

All Voltage Regulators have built-in capacitors that provide high voltage spike protection.

18-5741
VOLTAGE REGULATOR

Replaces: 815279A2, 815279-1
For: Mercury engines with 16 amp or 40 amp charging system model/years 1989-91

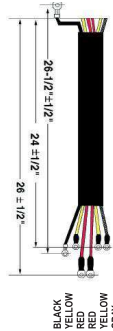

18-5743
VOLTAGE REGULATOR

Replaces: 815279-3, 815279-5, 883072T
For: Mercury engines with 16 amp or 40 amp charging system model/years 1992 to present
***Note:** Black wire (not pictured) goes to engine ground.

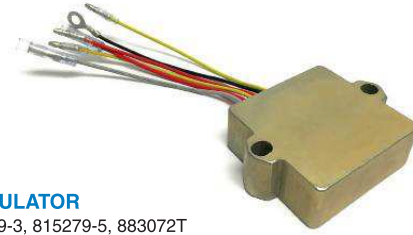

18-5732
VOLTAGE REGULATOR

Replaces: 893640T01
Fits: 30/40/50/60 EFI 4 Stroke

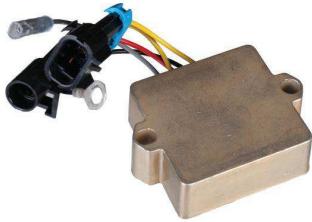

18-5707
RECTIFIER

Replaces: 62351A1, 62351A2, 816770, 816770T
All applications with square, 3 post rectifier



① **18-5802D**

Display Package

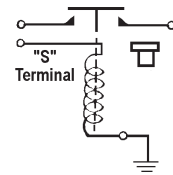

18-5802
SOLENOID

Replaces: 65057A1, 65057T1, 65057, 54981

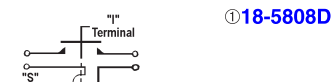

① **18-5808D**

Display Package



18-5808
SOLENOID

Replaces: 47886, 47886T

① **18-5810D**

Display Package

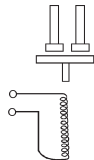

18-5810
SOLENOID
Horizontal Post



18-5811
STARTER SOLENOID

Replaces: 809463A1, 8094631, 809463, 8094621, 809462
For: PG260 Series Starters, (Verado 200-275 HP), (75/95 1.5L DFI), (115/135/150/175/200 2.5L DFI), (225 3.0L DFI)

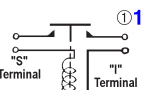

① **18-5815D**

Display Package



18-5815
SOLENOID

Replaces: 89-68258A4, 89-853654A1, 89-76545, 89-76545T, 89-65258, 89-61053, 89-15857

① **18-5816D**

Display Package

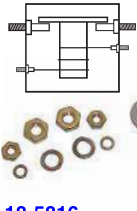

18-5816
SOLENOID

Replaces: 89-96054, 89-96054T, 89-91975
Flat Bracket

① **18-5817D**

Display Package

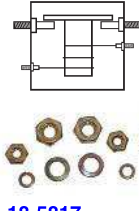

18-5817
SOLENOID

Replaces: 89-96158, 89-96158T, 94318, 846070
Vertical Post, Angled Bracket

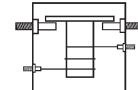

18-5818
SOLENOID

Replaces: 89-818864, 89-818864T

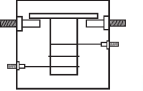

18-5819
SOLENOID

Replaces: 89-818997A1, 89-818997T1, 89-818997A2

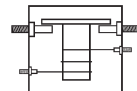

18-5820
SOLENOID

Replaces: 89-818999A2, 89-825842A1, 89-850188T1

18-5821
STARTER SOLENOID

Replaces: 89-825096T, 825096T01
Fits: 9.9 4-Stroke(1999 & Up), 15 4-stroke (1999 & Up), 30 4-stroke(2002 & Up), 40/50/60 4-stroke(2001 & Up), 75/90 4-stroke(2000 & Up)



① **18-5822D**

Display Package

18-5822
CHOKE SOLENOID

Replaces: 54293A13, 54293A10, 54293A4
Fits: 75 4cyl (1984 & Up), V150 (1978 & Up), V150 Magnum (1978-85), V150 Marathon (1978-85), V150 XR 2 (1978-85), V1500 (1978-85), V175 (1976-99), V1750 (1976-88), V200 (1978 & Up), V2000 (1978-88)



APPLICATION ON NEXT PAGE

① Items ending in "D" are Display Packaged - Regular number is Non-Display

 <p>18-5834 SOLENOID Replaces: 89-817109A2 For: 75 HP (3 cyl.) S/N G127500 & UP</p>	<p>① 18-5836D Display Package</p>  <p>18-5836 SOLENOID Replaces: 25661, 256611, 25661T1</p>	 <p>18-5729 POWER TRIM RELAY Replaces: 87-18211 For: 35 (2 cyl.) (with Ram Trim) OC159200 & UP 60 (3 cyl.) (with Ram Trim) OB122920 - OD000749</p>	 <p>18-5737 POWER TRIM RELAY Replaces: 87-19761 For: 40 (4 cyl.) (with Relays) OC159200 & UP</p>
 <p>18-5849 RELAY, SHROUDED, TRIM Replaces: 882751A1, 828151A1, 828151, 882751A2 Fits: Power Trim Relay used on most 2-stroke and 4-stroke (non-Verado®) engines.</p>	 <p>18-5850 RELAY, SHROUDED Replaces: 882751A04 Fits: 135hp. - 350hp Verado (2005 - Current); 496Mag & 496HO (2004 - Current); 8.1HO (2004 - Current)</p>	 <p>18-5851 RELAY, SHROUDED Replaces: 865202T, 807057T, 807057</p>	 <p>18-5852 RELAY, SHROUDED Replaces: 821509T01, 821509, 853292 Fits: Four-Stroke: 45hp (0G231123-0G472132); 50hp. (0G231123-0T178499)</p>

① Items ending in "D" are Display Packaged - Regular number is Non-Display

SOLENOID APPLICATION

HP	Beg. S/N	End. S/N	Starter Solenoid/Relay	Power Trim Solenoid	Power Trim Relay
4-Stroke					
9.9 (4-Stroke)(323cc)	0G760300	0T979999	18-5821	—	—
15 (4-Stroke)(323cc)	0G760300	1B727495	18-5821	—	—
30 (4-Stroke) Carb	0G760300	& Up	—	—	18-5849
30 (4-Stroke) EFI	0T409000	1B226999	18-5821	—	18-5849
40 (4-Stroke)(3 cyl) Carb	0G760300	& Up	—	—	18-5849
40 (4-Stroke)(3 cyl) EFI	0T409000	& Up	18-5821	—	18-5849
40 (4-Stroke)(4 cyl) Carb	0T228405	0T598999	18-5821	—	18-5849
40 (4-Stroke)(4 cyl) EFI	0T409000	& Up	18-5821	—	18-5849
45 (4-Stroke) Bodensee	0G231123	0G472132	18-5821	—	18-5852
45 (4-Stroke) Bodensee	0G472133	0T178499	18-5821	—	18-5849
50 (4-Stroke)	0G231123	0T178499	18-5821	—	18-5852
50 (4-Stroke)(4 cyl) Carb 996cc	0T178500	0T598999	18-5821	—	18-5849
50 (4-Stroke)(4 cyl) EFI 996cc	0T409000	& Up	18-5821	—	18-5849
60 (4-Stroke)(4 cyl) Carb 996cc	0T178500	0T598999	18-5821	—	18-5849
60 (4-Stroke)(4 cyl) EFI 996cc	0T409000	& Up	18-5821	—	18-5849
75 (4-Stroke) Carb 1596cc	0G960500	1B226999	18-5821	—	—
75 (4-Stroke) EFI 1596cc	1B366823	& Up	18-5834	—	—
90 (4-Stroke) Carb 1596cc	0G960500	1B226999	18-5821	—	—
90 (4-Stroke) EFI 1731cc	1B366823	& Up	18-5821	—	—
115 (4-Stroke) EFI w/ 2 relay trim	0T178500	0T800999	—	—	18-5849
115 (4-Stroke) EFI 1731cc	0T809000	1B366822	—	—	18-5849
115 (4-Stroke) EFI 1731cc	1B366823	& Up	18-5821	—	—
135 (4-Stroke) Verado	1B227000	& Up	18-5850	—	18-5850
150 (4-Stroke) Verado	1B227000	& Up	18-5850	—	18-5850
175 (4-Stroke) Verado	1B227000	& Up	18-5850	—	18-5850
200 (4-Stroke)(4 cyl) Verado	1B517159	& Up	18-5850	—	18-5850
200 (4-Stroke)(6 cyl) Verado	0T980000	& Up	18-5850	—	18-5850
225 (4-Stroke)(6 cyl) Verado	0T980000	& Up	18-5850	—	18-5850
250 (4-Stroke)(6 cyl) Verado	0T980000	& Up	18-5850	—	18-5850
275 (4-Stroke)(6 cyl) Verado	0T980000	& Up	18-5850	—	18-5850
300 (4-Stroke)(6 cyl) Verado	1B517434	& Up	18-5850	—	18-5850
350 (4-Stroke)(6 cyl) Verado	1B716557	& Up	18-5850	—	18-5850
2-Stroke					
HP	Beg. S/N	End. S/N	Starter Solenoid	Power Trim Solenoid	Power Trim Relay
6/8/9.9	A197112	OD280999	18-5816	—	—
15	A197112	OD280999	18-5816	—	—
18	5837437	& UP	18-5816	—	—
20	4709593	6443972	18-5815	—	—
20	6443973	0G044026	18-5816	—	—
25	5705532	G044026	18-5816	—	—
30 (2 cyl) 644cc	G053314	& UP	—	—	18-5849
30 JET non-handle	C159200	G589999	18-5816	—	—
35 2 cyl (w/ 3 Ram Trim)	6445653	C159199	18-5817	18-5817	—

① Use 18-5817 for applications with circuit breaker and fuse. ③ For units with 10-32, 5/16-18 terminals. ⑤ For design II applications use 18-5820.
 ② For units with 8-32, 1/4-20 terminals. ④ Use 18-5818 if off white solenoid is needed. ⑥ w/rubber bushing solenoid

SOLENOID APPLICATION

HP	Beg. S/N	End. S/N	Starter Solenoid	Power Trim Solenoid	Power Trim Relay
35 2 cyl (w/ 1 Ram Trim)	C159200	& UP	18-5817	—	18-5729
40 2 cyl	2874704	5556229	18-5836	—	—
40 2 cyl	5556230	5823917	18-5815	—	—
40 2 cyl	5823918	G053313	18-5817	—	—
40	G053314	& UP	18-5816 ⑤	—	—
40 4 Cyl.(w/solenoids)	C159200	& UP	18-5816	18-5820	—
40 4 Cyl.(w/relays)	C159200	& UP	18-5816	—	18-5737
45 4 Cyl.(w/o circuit breaker)	5531630	6146848	18-5815	18-5815	—
45 4 Cyl.(w/circuit breaker)	5531630	6146848	18-5815	18-5817	—
45 4 Cyl.(w/o circuit breaker)	6146849	B110788	18-5817	18-5815 ①	—
45 4 Cyl.(w/circuit breaker)	6146849	B110788	18-5817	18-5817	—
45 4 Cyl.	B110789	& UP	18-5817	18-5817	—
45 JET (w/flush mount solenoid)	D000750	G290584	18-5816	—	—
45 JET	G290585	G589999	18-5820	—	—
50	3008819	4140999	18-5836	—	—
50	4141000	5531629	18-5815	—	—
50 4 Cyl.(w/circuit breaker)	5531630	6146848	18-5815	18-5815 ①	—
50 4 Cyl.(w/circuit breaker)	5531630	6146848	18-5815	18-5817	—
50 4 Cyl.(w/o circuit breaker)	6146849	& UP	18-5817	18-5815 ①	—
50 4 Cyl.(w/circuit breaker)	6146849	& UP	18-5817	18-5817	—
50 3 Cyl.	6428681	B122929	18-5816	18-5817	—
50 3 Cyl. (w/ 3 Ram Trim)	B122930	C160935	18-5817	18-5817	—
50 3 Cyl. (w/ 1 Ram Trim)	B122930	D000749	18-5817	—	18-5729
50 3 Cyl.	D000750	G290584	18-5816	—	18-5849
50 3 cyl	G290585	G589999	18-5820	—	18-5849
50 3 cyl	G590000	& UP	—	—	18-5849
55 3 Cyl.	D000750	G290584	18-5816 ⑤	—	18-5849
55 3 Cyl.	G290585	G589999	18-5820	—	18-5849
60 3 Cyl.	6428681	B122929	18-5816	18-5817	—
60 3 Cyl. (w/solenoids)	B122930	D000749	18-5817	18-5817	—
60 3 Cyl. (w/relays)	B122930	D000749	18-5817	—	18-5729
60 3 Cyl.	D000750	G290584	18-5816 ⑤	—	18-5849
60 3 Cyl.	G290585	G589999	18-5820	—	18-5849
65 4 Cyl.	2446775	3293183	18-5836	—	—
65 3 Cyl.	3547987	4571651	18-5815	—	—
65 JET	G127500	& UP	18-5834	—	—
70 3 Cyl.	4571652	5579016	18-5815	—	—
70 3 Cyl.	5579017	6104369	18-5815	18-5815 ①	—
70 3 Cyl.	6104370	6428680	18-5816	18-5815 ①	—
70 3 Cyl.	A996147	& UP	18-5817	18-5817	—
75 4 Cyl.	6432901	& UP	18-5816	18-5817	—
75 3 cyl w/ 1 Ram Trim	C222000	D252460	—	—	18-5849
75 3 Cyl.	D252461	G127499	18-5817	18-5819	—
75 3 Cyl.	G127500	G360002	18-5834	18-5819	—
75 3 Cyl.	G360003	& UP	18-5834	—	18-5849
75 Optimax 3 cyl (1.5L)	T801000	& UP	18-5834	—	18-5849
80	2559001	3493912	18-5836	—	—
80 4 Cyl.	4831999	5582561	18-5815	—	—
80 4 Cyl.	5582562	6030903	18-5815	18-5815 ①	—
80 4 Cyl.	6030904	6432900	18-5816	18-5815 ①	—
80 3 Cyl.	A996142	& UP	18-5817	18-5817	—
80 JET 4 cyl	D283222	& UP	18-5834	—	—
80 JET 3 cyl	B586067	& UP	18-5834	—	18-5849
85 4 Cyl.	3493913	3865694	18-5836	—	—
85 4 Cyl.	3865695	4831998	18-5815	—	—
90	4845301	5299505	18-5815	18-5815	—
90	5299506	6026608	18-5815	18-5815 ①	—
90	6026609	6436122	18-5816	18-5815 ①	—
90	6436123	& UP	18-5816	18-5817	—
90 3 Cyl.	A996142	C221999	18-5817	18-5817	—
90 3 Cyl. w/ 1 Ram Trim	C222000	D252460	—	—	18-5849
90 3 Cyl.	D252461	G127499	—	18-5819	—
90 3 Cyl.	G127500	G360002	18-5834	18-5819	—
90 3 Cyl.	G360003	& UP	18-5834	—	18-5849
90 Optimax 3 cyl (1.5L)	T801000	& UP	18-5834	—	18-5849
100 6 Cyl.	2318586	3253111	18-5836	—	—
100 4 Cyl. w/ 1 Ram Trim & 5/16-18 starter terminal	B209468	D252460	18-5834	—	18-5849
100 4 Cyl. w/ 3 Ram Trim & 5/16-18 starter terminal	B209468	D252460	18-5834	—	—
100 4 Cyl.	D252461	G359967	18-5834	18-5819	—
100 4 Cyl.	G359968	& UP	18-5834	—	18-5849
105 JET w/ flush mounted starter solenoid	D082000	G303045	18-5815	—	—
105 JET w/ rubber mounted starter solenoid	D082000	G303045	18-5834	—	—
105 JET	G303046	& UP	18-5834	—	—
110 6Cyl.	1870204	2314955	18-5836	—	—
115	2836019	4112634	18-5836	18-5836	—
115	4112635	5600966	18-5815	18-5815	—
115	5600967	6051525	18-5815	18-5815 ①	—
115	6051526	6436122	18-5816	18-5817 ①	—
115	6436123	& UP	18-5816	18-5817	—
115 4 Cyl. w/ 3 Ram Trim & 5/16-18 starter terminal	C100000	D252460	18-5834	—	—
115 4 Cyl. w/ 1 Ram Trim & 5/16-18 starter terminal	C100000	D252460	18-5834	—	18-5849
115 4 Cyl.	D252461	G359967	18-5834	18-5819	—
115 4 Cyl.	G359968	& UP	18-5834	—	18-5849
115 Optimax 3 cyl (1.5L)	T801000	& UP	18-5834	—	18-5849

① Use 18-5817 for applications with circuit breaker and fuse.

③ For units with 10-32, 5/16-18 terminals.

⑤ For design II applications use 18-5820.

② For units with 8-32, 1/4-20 terminals.

④ Use 18-5818 if off white solenoid is needed.

⑥ w/rubber bushing solenoid

SOLENOID APPLICATION

HP	Beg. S/N	End. S/N	Starter Solenoid	Power Trim Solenoid	Power Trim Relay
115 Pro XS	B751825	& UP	18-5834	—	18-5849
125	2314956	3253111	18-5836	—	—
125 4 Cyl.	D283222	G359967	18-5834	18-5819	—
125 4 Cyl.	G359968	& UP	18-5834	—	18-5849
125 Optimax 3 cyl (1.5L)	B736885	& UP	18-5834	—	18-5849
135	2839369	3293233	18-5836	—	—
V135	A904646	C100860	18-5815 ③	18-5817	—
V135	A904646	C100860	18-5816 ②	18-5817	—
V135	C100861	C239552	18-5815	18-5817	—
V135	C239553	D081999	18-5815 ④	18-5817	—
V135 (w/flush mounted solenoid)	D082000	G201874	18-5815	18-5819	—
V135 (w/rubber bushing solenoid)	D082000	G201874	18-5834	18-5819	—
V135 (w/flush mounted solenoid)	G201875	G303045	18-5815	—	18-5849
V135 (w/rubber bushing solenoid)	G201875	G303045	18-5834	—	18-5849
V135	G303046	& UP	18-5834	—	18-5849
V135 DFI	G590000	& UP	18-5834	—	18-5849
140	3293234	3502805	18-5836	18-5836	—
140	4865678	& UP	18-5815	18-5815	—
140 JET	G303046	T178499	18-5834	—	18-5849
150	3502806	4121434	18-5836	18-5836	—
150	4121435	4865677	18-5815	18-5836	—
150 XS	4868648	5327662	18-5815	18-5815	—
V150	4868998	6042945	18-5815	18-5817	—
V150	6042946	A904645	18-5816	18-5817	—
V150	A904646	C100860	18-5815 ③	18-5817	—
V150	A904646	C100860	18-5817 ②	18-5817	—
V150	C100861	C239552	18-5815	18-5817	—
V150	C239553	D081999	18-5815 ④	18-5817	—
V150, 150 EFI w/flush mounted solenoid	D082000	G201874	18-5815	18-5819	—
V150, 150EF w/rubber mount solenoid	D082000	G201874	18-5834	18-5819	—
V150, 150 EFI w/flush mounted solenoid	G201875	G303045	18-5815	—	18-5849
V150, 150EF w/rubber mount solenoid	G201875	G303045	18-5834	—	18-5849
V150, 150 EFI	G303046	& UP	18-5834	—	18-5849
V150 DFI	G590000	& UP	18-5834	—	18-5849
150 XR-4/Magnum II	B242885	C239552	18-5815	18-5817	—
150 XR-4/Magnum II w/standard color solenoid	C239553	D081999	18-5815	18-5817	—
150 XR-4/Magnum II w/off white color solenoid	C239553	D081999	18-5815	18-5818 ⑥	—
150 XR-6/Magnum III w/flush mounted solenoid	D082000	G201874	18-5815	18-5819	—
150 XR-6/Magnum III w/rubber mounted solenoid	D082000	G201874	18-5834	18-5819	—
150 XR-6/Magnum III	G201875	G303045	18-5815	—	—
150 XR-6/Magnum III w/flush mounted solenoid	G201875	G303045	18-5815	—	18-5849
150 XR-6/Magnum III w/rubber mounted solenoid	G201875	G303045	18-5834	—	18-5849
150 XR-6/Magnum III	G303046	& UP	18-5834	—	18-5849
V175	4301235	6618750	18-5815	18-5815	—
V175	6618751	C239552	18-5816 ②	18-5817	—
V175	6618751	C239552	18-5815 ③	18-5817	—
V175	C100861	C239552	18-5815	18-5817	—
V175	C239553	D081999	18-5815 ④	18-5817	—
V175, 175 EFI w/flush mounted solenoid	D082000	G201874	18-5815	18-5819	—
V175, 175 EFI w/rubber mounted solenoid	D082000	G201874	18-5834	18-5819	—
V175, 175 EFI w/flush mounted solenoid	G201875	G303045	18-5815	—	18-5849
V175, 175 EFI w/rubber mounted solenoid	G201875	G303045	18-5834	—	18-5849
V175, 175 EFI	G303046	& UP	18-5834	—	18-5849
V175 DFI	G590000	& UP	18-5834	—	18-5849
V175 Pro XS	B516339	& UP	18-5834	—	18-5849
V200	4839034	6073191	18-5815	18-5815	—
V200	6073192	6225220	18-5816	18-5817	—
V200	6625221	C100860	18-5816 ②	18-5817	—
V200	6625221	C100860	18-5815 ③	18-5817	—
V200	C100861	C291519	18-5815	18-5817	—
V200 (2.5L)	C291520	D081999	18-5815 ④	18-5817	—
V200 w/flush mounted solenoid	D082000	G201874	18-5815	18-5819	—
V200 w/rubber mounted solenoid	D082000	G201874	18-5834	18-5819	—
V200, 200 EFI (w/flush mounted solenoid)	D082000	G201874	18-5815	18-5819	—
V200, 200 EFI (w/rubber bushing solenoid)	D082000	G201874	18-5834	18-5819	—
V200, 200 EFI (w/flush mounted solenoid)	G201875	G303045	18-5815	—	18-5849
V200, 200 EFI (w/rubber bushing solenoid)	G201875	G303045	18-5834	—	18-5849
V200, 200 EFI	G303046	& UP	18-5834	—	18-5849
V200 DFI	G386496	& UP	18-5834	—	18-5849
V220 (Laser)	B117316	& UP	18-5815	18-5817	—
V225 2.4L	5628028	& UP	18-5815	18-5815	—
V225 3.0L	D280813	G129221	18-5834	18-5819	—
V225 3.0L	G129222	G303045	18-5834	18-5819	—
V225 3.0L	G129222	G303045	18-5834	—	18-5849
V225 3.0L	G303046	& UP	18-5834	—	18-5849
V225 DFI	G590000	& UP	18-5834	—	18-5849
V225 Sea Pro / Marathon	G245605	& UP	18-5834	—	18-5849
V225 Pro XS	B104549	& UP	18-5834	—	18-5849
V225/250 EFI	G129222	& UP	18-5834	—	18-5849
V250XB	G980600	& UP	18-5834	—	18-5849
V250 Pro XS	B426561	& UP	18-5834	—	18-5849
V250/275 (3.4L)	C101891	& UP	18-5815	18-5817	—
300 (3.4L)	5611648	& UP	18-5815	18-5817	—

① Use 18-5817 for applications with circuit breaker and fuse. ③ For units with 10-32, 5/16-18 terminals. ⑤ For design II applications use 18-5820.
 ② For units with 8-32, 1/4-20 terminals. ④ Use 18-5818 if off white solenoid is needed. ⑥ w/rubber bushing solenoid



18-5929
ALTERNATOR
Replaces: 892940T
All Verado's



18-6454
ALTERNATOR
Replaces: 875285T1, 8M0064021, 889955A03, 834832, 881248T, 857006T
5S/I 50 amp Spool mount
Fits: 2.5L



18-6455
ALTERNATOR
Replaces: 875286T, 875286A1, 881247A1
5S/I 50 amp
Fits: 1.5L and 3.0L
For: 200 DFI, 200 DFI/DTS, 225 EFI, 225 EFI, Sea Pro, 225 DFI/DTS, 250 EFI



18-6840
ALTERNATOR
Replaces: 50-897755T, 897755T
Fits: 75-115HP EFI (4-Stroke)



18-18000
SERPENTINE BELTS
Replaces: 57-892318
For: 75 DFI (2005-06), 90 DFI (2005-06), 15 DFI (2004-06)



18-15128
SERPENTINE BELTS
Replaces: 57-880566014
Fits: All Verados-135-275HP

18-18100
SERPENTINE BELTS

Replaces: 57-828507Q4
For: 135 DFI (1998-Up), 150 DFI (1998-Up), 175 DFI (2001-Up)

18-15129
SERPENTINE BELTS

Replaces: 57-828507 1
Fits: 200 DFI (1997 & Up), 225 DFI (1998 & Up)

18-6500
SERVICE END ALTERNATOR HARNESS
Replaces: 84-881262A2
Fits: Optimax (1998-01) For: Delco Alternators



ALL STARTERS ARE COUNTER CLOCKWISE ROTATION



18-6435
STARTER
Replaces: 50-888161T, 50-884044T, 50-859377T, 50-893888T
Fits: 40,50,60 HP 4 Stroke 4 Cyl, 0P094500 & UP: 50,60 HP EFI 4 Stroke 4 Cyl, 0P153500-UP



18-6436
STARTER
Replaces: 50-859171T, 50-834749, 50-898265001
Fits: 40HP Italy 4 Stroke 0G760300-UP: 45HP Bodensee 0G760300-UP: 50HP 4 Stroke 0G760300-UP: 50HP Bigfoot 4 Stroke 0G760300-UP

ALL STARTERS ARE COUNTER CLOCKWISE ROTATION



**18-6437
STARTER**
Replaces: 50-888151T,
50-830308T, 50-859169T,
50-893886T
Fits: 25HP 4 Stroke OG760300 & UP



**18-6438
STARTER**
Replaces: 50-888160T, 50-884045T, 50-
859170T, 50-854636T, 50-893887T
Fits: 30,40HP 3 Cyl 4 Stroke OG760300 & UP



**18-6425
STARTER**
Replaces: 50-804312T1
For: 4 Stroke 75 HP, and 90HP except Verado



**18-6440
STARTER**
Replaces: 50-892339T, 50-853329T
Fits: 90, V135, V150, V175, V200, 2.5L DFI, 0T178500 &
UP; 200, 250HP, 3.0L, 0T467442 & UP, and Inline 4 and
6 cyl. Verados. Models with solenoid operated bendix.



**18-5601
STARTER**
Replaces: 50-55601, 50-55601A2,
50-38890A1
Fits: 35-50 HP models



**18-5602
STARTER**
Replaces: 50-67341, 50-58788A3,
50-893891T, 50-44369A1
Fits: 35-40 HP, 2 cyl. & 50 HP, 4 cyl. models



**18-5642
STARTER**
Replaces: 50-66015, 50-66015T,
50-893891T, 50-44369A1
Fits: 50-90 HP models (1976-99), 10 Tooth Drive Gear



**18-6282
STARTER**
Replaces: 50-8329972, 50-832997003
Fits: Mercury V6 Jet (1996 and up), 8 Tooth Drive Gear



**18-6283
STARTER**
Replaces: 50-8331535,
50-898265008
For: Mercury 2.5 DFI(1999 and up), 200HP V6
DFI(1996-99), 225HP V6 DFI(1998 and up), 3.0L
V6(1999 and up) 9 Tooth Drive Gear
Uses Drive Kit [18-5658](#)



**18-5605
STARTER**
Replaces: 50-73521, 50-73521T,
50-898265005
Fits: 40-50 HP models



**18-5606
STARTER**
Replaces: 50-44369, 50-60315, 50-44369A1
50-898265012
Fits: 50-70 HP models (1976-94)



**18-5608
STARTER**
Replaces: 50-44415, 50-77141, 50-79472, 50-
44414, 50-79472 1, 50-893893
Fits: 2.5L, 3.4L & 135 Jet models

APPLICATION ON PAGE 375

ALL STARTERS ARE COUNTER CLOCKWISE ROTATION



**18-5610
STARTER**

Replaces: 50-66015T, 50-660151, 50-660153, 50-893892T, 50-893892T
(8 Tooth)
Fits: 1.7L, 1.9L & 1.4L (1988-2008)



**18-5611
STARTER**

Replaces: 50-90983A-1, 50-90983T1, 50-8M0033984
For: 6-15 HP (1986-96), 18-25 HP (1980-87), 10 tooth drive gear



**18-5620
STARTER**

Replaces: 50-818445-3, 50-818445-2, 50-818445 5, 50-898265009
Fits: 2.5L, 3.0L & 225-250 HP models (1993-2000)



**18-5621
STARTER**

Replaces: 50-822462, 50-822462T1, 50-893890T
Fits: 30-60 HP models



**18-5636
STARTER**

Replaces: 50-57465A1, 50-57867, 50-64975, 50-72467, 50-58788A3
Length: 11 1/2"
Fits: 65-175 HP models (1973-88)



**18-6824
OUTBOARD STARTER**

Replaces: 50-60594A, A1, T01
Fits: 2.0, 2.4, and 2.5L Racing Engines



**18-6825
STARTER**

Replaces: 50-86976
(9 Tooth)
Fits: 200-225HP V6 engines



**18-6828
STARTER**

Replaces: 50-41583
Fits: 35, 35 (2 CYL.), 402, 40 (2 CYL.)



**18-6829
STARTER**

Replaces: 50-852570, T, 50-857065, 50-859168, T, 859168, T
Fits: Mercury, Mariner 9.9-15HP 4-Stroke Engines



**18-6864
STARTER**

Replaces: 50-819271, 50-820193A1
Fits: Mercury 40-50HP Engines



**18-6940
STARTER**

Replaces: 50-825991A2
Fits: 9.9HP 4- Stroke Engines



**18-6943
STARTER**

Replaces: 50-893894
Fits: 9.9-15HP Engines

APPLICATION ON NEXT PAGE

ALL STARTERS ARE COUNTER CLOCKWISE ROTATION



**18-6250
STARTER REPAIR KIT**
Prestolite
2 Brush



**18-6251
STARTER REPAIR KIT**
Prestolite
4 Brush



**18-5697
DRIVE BRUSH KIT**
Replaces: 75384
See chart below for additional application



**18-5650
DRIVE ASSEMBLY**
Replaces: 57380
See chart below for additional application



**18-5656
DRIVE ASSEMBLY**
Replaces: 68575
See chart below for additional application



**18-5658
DRIVE ASSEMBLY**
Replaces: 86177, 86177 1
(10 Tooth)
See chart below for additional application



**18-5674
DRIVE ASSEMBLY**
Replaces: 75661, 13310T1
(8 Tooth)
See chart below for additional application

MERCURY

H.P.	Beg. Serial #	Ending Serial #	O.E.M #	Starter #	O.E. #	Drive Assembly	O.E. #	Drive Tooth Count	Brush Kit	O.E. #	
6	A197112	& Up	50-8M0033984/50-90983A1	18-5611	96562		—	10	—	—	
7.5	3801458	4851692	50-73531	⑥	96562		96562/75427	10	18-5697	75384	
7.5	4851693	& Up	50-78011	⑥	96562		96562/75427	10	18-5697	75384	
8/9.9/15	A197112	& Up	50-8M0033984/50-90983A1	18-5611	96562		—	10	—	—	
18	5837437	& Up	50-8M0033984/50-90983A1	18-5611	96562		—	—	—	—	
20	4709593	6443973	50-76275	⑥	96562		96562/75427	10	—	—	
20	6443973	& Up	50-8M0033984/50-90983A1	18-5611	96562		—	10	—	—	
25	5705532	& Up	50-8M0033984/50-90983A1	18-5611	96562		—	10	—	—	
30 2 cyl.	G053314	& Up	50-893890T/50-822462	18-5621	N.L.A.	18-5656	68575	10	18-5697	75384	
30 JET	G159200	G589999	50-898265005/50-73521	18-5605	68575 3	18-5656	68575	10	18-5697	75384	
30 JET 3 cyl.	G590000	T408999	50-893890T/50-822462	18-5621	90643	18-5656	68575	10	18-5697	75384	
35 2 cyl.	6445653	& Up	50-41583T/50-41583	⑥	N.L.A.		43076/ 43076T	10	18-5697	75384	
35/40 2 cyl.	6445652	& DOWN	50-55601A2/50-55601	18-5601	N.L.A.	18-5650	57380	9	18-5697	75384	
40 2 cyl.	G053314	& Up	50-893890T/50-822462	18-5621	68575 3	18-5656	68575	10	18-5697	75384	
40H.P. 3 cy.	G590000	G760299	50-893890T/50-822462	18-5621	68575 3	18-5656	68575	10	18-5697	75384	
40 3 cyl.	G760300	& Up	50-893890T/50-822462	18-5621	68575 3	18-5656	68575	10	18-5697	75384	
40 4 cyl.	C159200	& Up	50-898265005/50-73521	18-5605	68575 3	18-5656	68575	10	18-5697	75384	
40 JET	T178500	& Up	50-893890T/50-822462	18-5621	68575 3	18-5656	68575	10	18-5697	75384	
45 4 cyl.	5531630	& Up	50-898265005/50-73521	18-5605	68575 3	18-5656	68575	10	18-5697	75384	
45 JET	D000750	G589999	50-44369A1/50-65436/50-60315	18-5606	⑧	68575 3	18-5656				
45 JET	G590000	T129554	50-893890T/50-822462	18-5621	68575 3	18-5656	68575	10	18-5697	75384	
50 4 cyl.	4357639	& Below	50-55601A2/50-38890A1	18-5601	N.L.A.	18-5650	57380	9	18-5697	75384	
50 4 cyl.	4357640	& Up	50-898265005/50-73521	18-5605	68575 3	18-5656	68575	10	18-5697	75384	
50 3 cyl.	B122930	G589999	50-44369A1	18-5606	⑧	68575 3	18-5656				
50 3 cyl.	G590000	& Up	50-893890T/50-822462	18-5621	68575 3	18-5656	68575	10	18-5697	75384	
55 3 cyl.	D000750	G589999	50-44369A1	18-5606	⑧	68575 3	18-5656				
55 3 cyl.	G590000	& Up	50-893890T/50-822462	18-5621	68575 3	18-5656	68575	10	18-5697	75384	
60 3 cyl.	6428681	G589999	50-44369A1/50-65436/50-60315	18-5606	⑧	68575 3	18-5656				
60 3 cyl.	G590000	& Up	50-893890T/50-822462	18-5621	68575 3	18-5656	68575	10	18-5697	75384	
60 3 cyl. Bigfoot	G590000	G760299	50-893890T/50-822462T 1	18-5621	68575 3	18-5656	68575	10	18-5697	75384	
65 4 cyl.	2803822	3293183	50-57867A1/50-58788	18-5636	68575 3	18-5656	68575	10	18-5697	75384	
65 3 cyl.	3293184	4571651	50-44369A1/50-65436/50-60315	18-5606	68575 3	18-5656					
65 Jet	D283222	& Up	50-893891T/50-66015	18-5642	68575 3	18-5656	68575	10	18-5697	75384	
70 3 cyl.	457165	A996142	50-44369A1/50-65436/50-60315	18-5606	68575	18-5656					
80 4 cyl.	2783253	3493912	50-57867A1/50-58788	18-5636	N.L.A.		68575	10	18-5697	75384	
80 4 cyl.	4831999	& Up	50-893891T/50-66015	18-5642	⑦	68575 3	18-5656	68575	10	18-5697	75384
85 4 cyl.	3865694	& Below	50-58788A3/50-58788	18-5636	N.L.A.	18-5656	68575	10	18-5697	75384	
85 4 cyl.	3865695	4366801	50-67341	18-5602	68575 3	18-5656	68575	10	18-5697	75384	
80 Jet	D283222	& Up	50-893892T/50-66015-1	18-5610	68575 3	18-5656	75660/13310T1	8	18-5697	75384	
90	② 4845301	& Up	50-72467/50-64975/50-57465A1	18-5636	68575 3	18-5656	68575	10	18-5697	75384	
90 3 cyl.	A996142	& Up	50-893891T/50-66015	18-5642	68575 3	18-5656	68575	10	18-5697	75384	
100 4 cyl.	B209468	G965520	50-893892T/50-66015-1	18-5610	68575-3	18-5674	75660/13310T1	8	18-5697	75384	
105 JET	G760299	& Below	50-893893/50-44414/50-44415/50-79472/50-77141	18-5608	13310T 1	18-5674	75660/13310T1	8	18-5697	75384	
115 6 cyl.	② 4855153	& Up	50-72467/50-64975/50-57465A1	18-5636	68575 3	18-5656	68575	10	18-5697	75384	
115 4 cyl.	C100000	& Up	50-893892T/50-66015-1	18-5610	68575 3	18-5674	75660/13310T1	8	18-5697	7538	
125 4 cyl.	D283222	& Up	50-893892T/50-66015-1	18-5610	68575 3	18-5674	75660/13310T1	8	18-5697	75384	
135 V-6	A904646	G960499	50-893893/50-79472/50-77141/50-44414/50-44415	18-5608	13310T 1	18-5674	75660/13310T1	8	18-5697	75384	

Note: Some starters will replace Prestolite versions however replacement parts are for Bosch versions only. ④ With 8 tooth pinion ⑦ Bosch models only
 ⑤ With 9 tooth pinion ⑧ Some applications require Mercury adapter #44368 (prior to S/N 0D000750)
 ② Inline 6 cylinder ⑥ No replacement starter available, drive parts only

MERCURY

H.P.	Beg. Serial #	Ending Serial #	O.E.M #	Starter #	O.E. #	Drive Assembly	O.E. #	Drive Tooth Count	Brush Kit	O.E. #
140 6 cyl. Inline ②	4865678	& UP	50-72467/50-64975/50-57465A1	18-5636	68575 3	18-5656	68575	10	18-5697	75384
140 JET	G960499	& Below	50-893893/50-44414/50-44415/ 50-79472/50-77141	18-5608	1310T 1	18-5674	75660/13310T1	8	18-5697	75384
150 ②	4121435	& Up	50-72467/50-64975/50-57465A1	18-5636	68575 3	18-5656	68575	10	18-5697	75384
V150	4868998	G960499	50-793793/50-79472/50-77141	18-5608	13310T 1	18-5674	75660/13310T1	8	18-5697	75384
150 XR2	4868998	A904645	50-44414,50-44415	18-5608	N.L.A.	18-5674	75660/13310T1	8	18-5697	75384
150 XR4	B242885	D819999	50-893893/50-79472/50-77141/ 50-44414/50-44415	18-5608	13310T 1	18-5674	75660/13310T1	8	18-5697	75384
150 XR6	D082000	G960499	50-893893/50-79472/50-77141/ 50-44414/50-44415	18-5608	13310T 1	18-5674	75660/13310T1	8	18-5697	75384
150 EFI	G303046	T408999	50-893893/50-79472/50-77141/ 50-44414/50-44415	18-5608	13310T 1	18-5674	75660/13310T1	8	18-5697	75384
V175	4301235	G960499	50-893893/50-79472/50-77141	18-5608	13310T 1	18-5674	75660/13310T1	8	18-5697	75384
175 EFI, XRI, MAG	D000750	G960499	50-893893/50-44414/50-44415	18-5608	N.L.A.	18-5674	75660/13310T1	8	18-5697	75384
200	4839034	G960499	50-893893/50-79472/50-77141	18-5608	13310T 1	18-5674	75660/13310T1	8	18-5697	75384
200 EFI, XRI	C100861	G960499	50-893893/50-44414/50-44415	18-5608	N.L.A.	18-5674	75660/13310T1	8	18-5697	75384
2.4EFI/2.5EFI/ 2.5 Carb/	ALL	—	50-893893/50-79472/50-77141/ 50-44414/50-44415	18-5608	13310T 1	18-5674	75660/13310T1	8	18-5697	75384
3.4L/MOD VP ④	ALL	—	50-893893/50-79472/50-77141/ 50-44414/50-44415	18-5608	13310T 1	18-5674	75660/13310T1	8	18-5697	75384
V200 ⑤	5363918	6435503	50-86976	18-6825	8677 1	18-5658	86177/86177 1	9	18-5697	75384
V225	5628028	D280812	50-86976	18-6825	8677 1	18-5658	86177/86177 1	9	18-5697	75384
225 3.0L Carb	D280813	T408999	50-898265009/50-818445-3/ 50-818445-2	18-5620	13310T 1	18-5674	75661/13310T1	8	18-5697	75384
225/250 EFI 3.0L	G129222	& Up	50-898265009/50-818445-3/ 50-818445-2	18-5620	13310T 1	18-5674	75661/13310T1	8	18-5697	75384
250XB	G980600	& Up	50-898265009/50-818445-3/ 50-818445-2	18-5620	13310T 1	18-5674	75661/13310T1	8	18-5697	75384

Note: Some starters will replace Prestolite versions however replacement parts are for Bosch versions only. ④ With 8 tooth pinion ⑦ Bosch models only
 ② Inline 6 cylinder ⑤ With 9 tooth pinion ⑧ Some applications require Mercury adapter #44368 (prior to S/N 0D000750)
 ⑥ No replacement starter available, drive parts only

**18-4915
STARTER ROPE**

Replaces: 50-12066A9, 50-12066Q9,
50-45093, 50-28985A2, 50-22791A1, 50-12066A1



**18-6506
REWIND SPRING**

Replaces: 24-29340A1, T1



REWIND SPRING APPLICATION

Model/HP	Beg. S/N	End S/N	Rewind Spring	Model/HP	Beg. S/N	End S/N	Rewind Spring
Merc 4	2498136	4107219	18-6506	Merc 35	1217222	1271884	18-6506
Merc 4.5	4107220	& UP	18-6506	Merc 35	1356948	1448139	18-6506
Merc 6	1408611	2387383	18-6506	Merc 35	1571114	1960826	18-6506
Merc 7.5	2529895	& UP	18-6506	Merc 35	1960827	2097279	—
Mar 8	M-677-000101	& UP	—	Merc 35	2097832	2258863	—
Merc 9.8	ALL		18-6506	Merc 35	2300962	2453068	—
Mar 9.9	M-682-000551	M-682-032885	—	Merc 35	2487558	2874703	—
Mark (10) 10	ALL		18-6506	Merc 35	6445653	& UP	—
Merc 10	1290910	1455239	18-6506	Mark (55) 40	831021	&UP	18-6506
Mark (15) 15	ALL		18-6506	Merc 40	1279685	1476509	18-6506
Merc 15	1288910	1349697	18-6506	Mar 40	ALL		—
Mar 15	M-684-000101	& UP	—	Merc 40	2874704	3336257	—
Merc 20	3537531	6443972	18-6506	Merc 40	3326258	& UP	—
Merc 20	1292910	3537530	18-6506	Merc 40	C159200	& UP	—
Mar 20	M-653-07615	& BELOW	—	Mark (58) 45	1139538	& UP	18-6506
Mar 20	M-653-07616	& UP	—	Merc 45	1476510	1531568	18-6506
Mar 20	M-6A9-000101	& UP	—	Merc 50	1421113	2116317	18-6506
Mark (28) 22	ALL		18-6506	Merc 50	5531630	& UP	— ②
Merc 25	1467499	1499331	18-6506	Merc 50	1770179	& UP	—
Mar 25	M-648-19025	& BELOW	& BELOW	Mark (75) 60	ALL		18-6506
Mar 25	M-695-000101	& UP	& UP	Merc 60	ALL		18-6506
Mar 28	ALL		—	Merc 65	1542745	1765043	18-6506
Merc 30	1271885	1356947	18-6506	Mark (78) 70	ALL		18-6506
Mar 30	ALL		18-6521	Merc 70	ALL		18-6506

① Above Prop Exhaust ② 4 cyl. only

 <p>18-7354 CARB KIT Replaces: 1395-8506 V-175 outboards Serial Number 4301235 thru OC100860</p>	 <p>18-7355 CARB KIT Replaces: 1395-811691 2</p>	 <p>18-7356 CARB KIT Replaces: 1395-811691 3</p>	 <p>18-7004 CARB KIT Replaces: 1395-6200</p>
 <p>18-7005 CARB KIT Replaces: 1395-6452</p>	 <p>18-7006-1 CARB KIT Replaces: 1399-1717, 1399-2015, 1399-3523, 1395-4808, 1395-8791994024, 879194024</p>	 <p>18-7007 CARB KIT Replaces: 1399-5135, 1399-5198</p>	 <p>18-7013 CARB KIT For: AJ, KA, KB, KC, KD Carburetor</p>
 <p>18-7021 CARB KIT For: WM, WMK</p>	 <p>18-7211-1 CARB KIT Replaces: 1395-8112231</p>	 <p>18-7212 CARB KIT Replaces: 1395-97611, 1395-9761, 1395-9803, 1395-9725, 1395-9645, 1395-9377, 1395-9179, 1395-811357</p>	 <p>18-7213 CARB KIT Replaces: 8107492</p>
 <p>18-7214 CARB KIT Replaces: 8107493</p>	 <p>18-7215 CARB KIT Replaces: 1395-9024</p>	 <p>18-7226 CARB KIT Replaces: 1395-9650 Fits: 30 JET, 40/45 4 CYL 4 Stroke, Carb models WMA-7B,9,10,13</p>	 <p>18-7290 CARB KIT Replaces: 84419M</p>
 <p>18-7291 CARB KIT Replaces: 84475M</p>	 <p>18-7293 CARB KIT Replaces: 92520M</p>	 <p>18-7738 CARB KIT Replaces: 802706A1 For: 9.9 4 Stroke (323cc) (1999 & up) and 15 4 Stroke (1998 & up)</p>	 <p>18-7743 CARB KIT Replaces: 804346T1 For: 75 4 Stroke (2000 & up), 90 4 Stroke (2000 & up)</p>

APPLICATION BEGINS ON NEXT PAGE



**18-7750-1
CARB KIT**
Replaces: 1395-8236354,
1395-8236353, 1395-8236352,
1395-8236351, 1395-823635,
1395-811222, 1395-9599
Fits: WME-1, 1A, 1B, 4, 5, 6, 6A, 7, 7B,
8, 9, 10, 10A, 11, 14, 15, 15A, 17, 18,
20, 20A, 21, 21A, 22, 22B, 23, 24, 26,
27, 28, 32, 32B, 33, 34, 35, 36, 36A, 37,
37A, 38, 39A, 40, 40A, 42, 42A, 43, 44,
45, 50, 52, 53, 57, 58, 63, 64, 65, 66, 67,
68, 69, 79, 81



**18-7765
CARB KIT**
Replaces: 11502M



**18-7769
CARB KIT**
Replaces: 814481M



**18-7770
CARB KIT**
Replaces: 84456M



**18-7815
CARB KIT**
Replaces: 1399-5137



**18-7062
INLET VALVE**
Replaces: 1395-95951
Fits: WME-1, 1A, 1B, 4, 5, 6, 6A, 7,
7B, 8, 9, 10, 10A, 11, 14, 15, 15A, 17,
18, 20, 20A, 21, 21A, 22, 22B, 23,
24, 26, 27, 28, 32, 32A, 33, 34, 35,
36, 36A, 37, 37A, 38, 39A, 40, 40A,
42, 42A, 43, 44, 45, 50, 52, 53, 57,
58, 63, 64, 65, 66, 67, 68, 69, 79, 81



**18-7057
NEEDLE & SEAT**
Replaces: 1399-1473,
1395-9258, 1399-1138,
1399-9258 1
.078 Bore

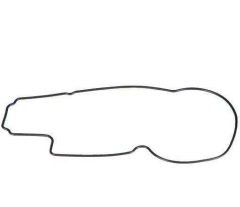

**18-0715
FLOAT CHAMBER
GASKET**
Replaces: 809086, 25-809086



**18-7061
NEEDLE & SEAT**
Replaces: 1395-8318,
1395-83181
.065 Bore



**18-7295
NEEDLE VALVE**
Replaces: 1395-9022



**18-7233
NEEDLE & SEAT**
Replaces: 1395-7824



**18-36850
NEEDLE & SEAT**
Replaces: 1395-8116901
Fits: Mercruiser 2.5 & 3.0L Carbs



**18-7380
FLOAT**
Replaces: 809569
15 (4-Stroke) All, 50 (4-Stroke)



**18-7381
FLOAT**
Replaces: 16253
4 (SN A855097 & Up),
5 (SN A855097 & Up)



**18-7382
FLOAT**
Replaces: 804184
75 (4-Stroke) All, 90 (4-Stroke) All



**18-7208
FLOAT**
Replaces: 1395-8983,
1395-8673



**18-72000
FLOAT**
Replaces: 1395-9594
Fits: WME1, 1A, 1B, 4, 5, 6, 6A, 7, 7B, 8, 9,
10, 10A, 11, 14, 15, 15A, 17, 18, 20, 20A,
21, 21A, 22, 22B, 23, 24, 26, 27, 28, 32,
32A, 33, 34, 35, 36, 36A, 37, 37A, 38,
39A, 40, 40A, 42, 42A, 43, 44, 45, 50,
52, 53, 57, 58, 63, 64, 65, 66, 67,
68, 69, 79, 81



**18-7249
FLOAT KIT**
Replaces: 19273
Fits: WM-3, 5, 6, 8, 9, 10, 11, 12, 13,
13A, 14, 15, 15A, 16, 16A, 17, 18



**18-7209
FLOAT**
Replaces: 1395-9293



**18-36956
FLOAT**
Replaces: 1395-9267
Fits: Mercury V6 w/ Dual Float
Carbs

MARINER CARBURETOR KIT APPLICATION

HP	Year/Serial No.	Carb Kit	HP	Year/Serial No.	Carb Kit	HP	Year/Serial No.	Carb Kit
6 C-D	Ser.No.Code 6H8 & 6H6	18-7765	25A	M-648-24991 & Up ML-648-64046 & Up E-648-27056 & Up EL-648-56526- & Up	18-7770	30A	M-689-230100 & Up ML-689-530100 & Up E-689-250100 & Up EL-689-550100 & Up	18-7770
8C	Ser.No.Code 6G1	18-7765						
9.9C	M-682-070796 & Up ML-682-368040 & Up E-682-251511 & Up EL-682-55146 & Up	18-7769						
15C	M-684-052848 & Up ML-684-332302 & Up E-684-252381 & Up EL-684-553251 & Up	18-7769	25C	Ser.No.Code 695	18-7770	48	M-670-02641 & Up ML-670-34581 & Up	18-7290
			28	M-664-05306 & Up ML-664-41686 & Up E-664-26236 & Up EL-664-57421 & Up	18-7770	W48	Ser.No.Code 670	18-7290
						55	Ser.No.Code 663	18-7290
W55	Ser.No.Code 663	18-7290	60	Ser.No.Code 675	18-7290			

MERCURY CARBURETOR KIT APPLICATION

HP	Year — S/N	Carburetor Model	Carburetor Kit	Gasket Kit	Needle & Seat	Float
3.9	1964-68	KB-7A,KB-7B	18-7013	18-7006-1	18-7057	18-7208
4 (1 cyl.)	1969-74, 80-81,86-87	KB-10A	18-7013	18-7006-1	18-7057	18-7208
4 (1 cyl.)		WMD-1	—	18-7006-1	18-7061	18-7208
4.5	1980-85	KD-10A	18-7013	18-7006-1	18-7057	18-7208
4.5	1980-85	WMD-1	18-7021	18-7006-1	18-7061	18-7208
6	1961-68	KB-6A,6B,7B,AJ57A	18-7013	18-7006-1	18-7057	18-7208
6	S/N A197112-Up	WMC-5,5A,5B,7,7A, 17,17B,17C,18,18A, 18B,19,19A,20,20A, 20B,23,28,34, 39,41,47,49	—	—	—	—
			—	—	—	—
			—	18-7212	—	—
7.5	1969-73	KB-9A,KB-12A	18-7013	18-7006-1	18-7057	18-7208

APPLICATION CONTINUED ON NEXT PAGE

MERCURY CARBURETOR KIT APPLICATION (Cont.)						
HP	Year — S/N	Carburetor Model	Carburetor Kit	Gasket Kit	Needle & Seat	Float
7.5	1972-85	BB-2A,BB-2B,BB-2C, BB-4A,BB-5A,BB-5B, BB5C,BB-5D,BB-7A, BB-7C	—	—	—	—
7.5		WMB-2, 4	—	—	18-7295	18-7209
8	S/N A197112-Up	WMC-5,5A,5B,7,7A, 17,17B,17C,18,18A, 18B,19,19A,20,20A, 20B,23,28,34, 39,41,47,49,57	—	—	18-7295	18-7209
9.8	1962-73	KB-5A,8A,11A	18-7013	18-7006-1	18-7057	18-7208
9.8	1972-85	BB-1B,BB-1C,BB-3A, BB-3B,BB-3C, BB-6A,BB-6C	—	—	—	—
9.8		WMB-1, 3	—	—	18-7295	18-7209
9.9 (2 stroke)	S/N A197112-Up	WMC-5,5A,5B,7,7A,17,17B, 17C,18,18A,18B,19,19A,20, 20A,20B	—	18-7212	—	—
9.9 (2 stroke)		WMC-23,28,34,39,41,41A, 47,47A,49,49A,57	—	18-7212	—	—
9.9 (4 stroke) (4 Stroke) (323cc)	S/N OG590000-Up	—	—	—	—	—
10	1957-61	AJ-52A	18-7013	18-7006-1	18-7057	18-7208
10		AJ-56AB	—	18-7006-1	18-7057	18-7208
10		KB-1A, 4A	—	18-7006-1	18-7057	18-7208
10 Seapro/ Marathon	All	WMC-33,33A,40,42, 50,50A,55,55A	—	18-7212	—	—
XR-10	All	WMC-23,48,48A,49,49A	—	18-7212	—	—
MAG 10	All	WMC-23,48,48A,49,49A	—	18-7212	—	—
15	1959-61	AJ-52A,AJ-56A	18-7013	18-7006-1	18-7057	18-7208
15(150)		KB-1A, 4A	—	18-7006-1	18-7057	18-7208
15	S/N A197112-Up	WMC-5,5A,5B,7,7A,17,17B, 17C,18,18A,18B,19,19A,20, 20A,20B	—	18-7212	—	—
15		WMC-23,28,34,39,41,41A, 47,47A,49,49A,57	—	18-7212	—	—
15	S/N OG590000-Up	—	18-7738	—	—	—
15 Seapro/ Marathon	All	WMC-33,33A,40,42, 50,50A,55,55A	—	18-7212	—	—
Super 15	S/N 6443973-Up	WMC-1,2,3,4,9,10, 11,12,13,13A,14, 14A,15A,16A,24,25, 26,27,29,30,31,31A, 32,32A,35,35A,35B, 36,37,44,45,46, 46A,50,53,54,56	—	—	—	—
Seapro/ Marathon	S/N 6443973-Up	WMC-1,2,3,4,9,10, 11,12,13,13A,14, 14A,15A,16A,24,25, 26,27,29,30,31,31A, 32,32A,35,35A,35B, 36,37,44,45,46,46A, 50,53,54,56	—	—	—	—
15XD/25		—	—	18-7212	—	—
15 (4-Stroke)	S/N OG590000-Up	—	18-7738	—	—	—
18	S/N 6443973-Up	WMC-1,2,3,4,9,10, 11,12	—	18-7212	—	—
18		WMC-13,13A,14,14A,15A, 16A,24,25,26,27,29,30,31, 31A	—	18-7212	—	—
20	S/N 6443973-Up	WMC-1,2,3,4,9,10, 11,12	—	18-7212	—	—
20		WMC-13,13A,14,14A,15A, 16A,24,25,26,27,29,30,31, 31A	—	18-7212	—	—
20 (200)	1963-72	KA-20A,22A,22B,22C,23A,25A	18-7013	18-7006-1	18-7057	18-7208
20	1973-80	BA-1A,BA-2A,BA-2C, BA-2D,BA-2E	—	18-7007	—	18-7209
Jet 20	S/N 6443973-Up	WMC-1,2,3,4,9,10,11, 12,13,13A,14,14A, 15A,16A,24,25,26, 27,29,30,31,31A,32, 32A,35,35A,35B,36, 37,44,45,46, 46A,50,53,54,56	—	—	—	—
22	1958-59	KA-KC	18-7013	18-7006-1	18-7057	18-7208
25 (2 cyl)	S/N 6443973-Up	WMC-1,2,3,4,9,10, 11,12	—	18-7212	—	—
25 (2 cyl)		WMC-13,13A,14,14A,15A, 16A,24,25,26,27,29,30,31, 31A,32,32A,35,35A,35B,36, 37,44,45,46,46A,50,53,54, 56	—	18-7212	—	—
30 (2 cyl)(644cc)	S/N G053314-Up	WME-36,36A,37,37A, 38,39A,42,42A, 63,64,65,66,67	—	—	—	—
30 (300) 4-cyl		AJ-54A	18-7750-1	18-7211-1	—	18-72000
30 (300) 4-cyl		KB-2A	—	17-7006-1	18-7057	18-7208
30 JET (3 cyl)		WME-53,68,69	18-7750-1	18-7211-1	—	18-72000
30 JET (4 cyl)		WMA-10,13	18-7226	—	—	—
35	1984-89	KC-4A,8A,9A,9B, 9C,13A	18-7013	18-7006-1	18-7061	18-7208
35	1963-69	KB-2A	18-7013	18-7006-1	18-7057	18-7208
35	1984-89	WMK-38	18-7021	18-7006-1	18-7061	18-7208

APPLICATION CONTINUED ON NEXT PAGE

MERCURY CARBURETOR KIT APPLICATION (Cont.)

HP	Year — S/N	Carburetor Model	Carburetor Kit	Gasket Kit	Needle & Seat	Float
35		AJ-54A	—	—	18-7057	18-7208
40	1960-61	KA-7A,KD-5A, KA-2A,KA-9A	18-7013	18-7006-1	18-7057	18-7208
40	1954-59	AJ	18-7013	18-7006-1	18-7057	18-7208
40	1970-74	WMK-1,WMK-8	18-7021	18-7006-1	18-7061	18-7208
40	1975-83	WMK-21,WMK-24, WMK-31	18-7021	18-7006-1	18-7061	18-7208
40 (2 cyl.)	S/N G053314-Up	WME-36,36A,37,37A, 38,39A,42,42A,63, 64,65,66,67	18-7750-1	18-7211-1	—	18-72000
40 (3 cyl.)		WME-53, 68, 69	18-7750-1	18-7211-1	—	18-72000
40 (4 cyl.)		WMA-4	—	18-7215	18-7295	18-7209
40 (4 cyl.)		WMA-7B	18-7226	—	—	18-7209
40 (4 cyl.)		WMA-9, 10, 13	18-7226	—	—	—
45	1958-62	KA-2A	18-7013	18-7006-1	18-7057	18-7208
45	1958-62	AJ-54A	18-7013	18-7006-1	18-7057	18-7208
45 (4 cyl.)	1986	Tillotson/Walbro	—	18-7007	—	18-7209
45 (4 cyl.)	1987-Up	WMA-4	—	18-7215	18-7295	18-7209
45 (4 cyl.)		KA-17A	18-7013	—	18-7057	18-7208
45 (4 cyl.)		WMA-7B	18-7226	—	—	18-7208
45 (4 cyl.)		WMA-9, 10, 13	18-7226	—	—	—
45 JET (3 cyl.)		WME-57, 58	18-7750-1	18-7211-1	—	18-72000
50 (4 cyl.)	1961-75	KA-13A,18A,19A, 21A,21B,21C,21D, 24A,26A,26B,27A	18-7013	18-7006-1	18-7057	18-7208
50	1976-85	BA-3B,BA-3C,BA-3D	—	18-7007	—	18-7209
50 (3 cyl.)	1986-90	WM-13, 13A, 15, 15A, 16, 16A, 18	—	18-7004	—	18-7249
50 (3 cyl.)		WME-22,22B,23,24,26, 27, 28, 35, 43, 44, 45, 53, 68, 69	18-7750-1	18-7211-1	—	18-72000
50 (4cyl.)	1986-Up	WMA-1,3	—	18-7215	18-7295	18-7209
50 (4cyl.)		BA-3A, 3B, 3C, 3D, 4A	—	18-7007	18-7295	18-7209
50 (4cyl.)		WMK-8	18-7021	18-7006-1	18-7061	18-7208
55 (3 cyl.)		WM-13, 13A, 15, 15A, 16, 16A, 18	18-7249	18-7004	—	—
55		WME-22, 22B, 23, 24, 26, 27, 28, 35, 43, 44, 45, 57, 58	18-7750-1	18-7211-1	—	18-72000
60 (3 cyl.)	S/N D000750-Up	WME-22,22B,23,24,26, 27, 28, 35, 43, 44, 45, 57, 58	18-7750-1	18-7211-1	—	18-72000
60 (3 cyl.)	1984-90	WM-13,13A, 15, 15A, 16, 16A, 18	—	18-7004	—	18-7249
60	1957-60	AJ-53A,AJ-55A,KB	18-7013	18-7006-1	18-7057	18-7208
60 600 (6 cyl.)		KB-3A	—	18-7006-1	18-7057	18-7208
65 650 (4 cyl.)	1963-71	KC-2A,5A,5B,5C, 11A,15A	18-7013	18-7006-1	18-7057	18-7208
65 650 (3 cyl.)	1972-75	WMK-5,WMK-12, WMK-13,WMK-20	18-7021	18-7006-1	18-7061	18-7208
65	1976	WM-2,WM-4	—	18-7004	18-7061	18-7208
Jet 65 (3 cyl.)	S/N A996142-Up	WME-1,1A,1B,4,5,6,6A, 7, 7B, 8, 9, 10, 10A, 15, 15A, 17, 18, 19, 25, 29, 30, 31, 41, 46, 47, 48, 49, 59, 60, 61, 62, 75, 76, 77	18-7750-1	18-7211-1	—	18-72000
70	1958-62	KC,KA-2A	18-7013	18-7006-1	18-7057	18-7208
70 700 (6 cyl.)		KA-8A, 12A	18-7013	18-7006-1	18-7057	18-7208
70	1977-83	WM-6,8, 9, 11	—	18-7004	18-7061	18-7249
70 (3 cyl.)	S/N A996142-Up	WME-1,1A,1B,4,5, 6,6A,7,7B,8,9,10, 10A,15,15A,17,18, 19,25,29,30,31,41, 46,47,48,49,59, 60,61,62	18-7750-1	18-7211-1	—	18-72000
75 (4 cyl.)	1984-86	WM-14, 17	—	18-7004	—	18-7249
75 (3 cyl.)	S/N A996142-Up	WME-1,1A,1B,4,5, 6,6A,7,7B,8,9,10, 10A,15,15A,17,18, 19, 25,29,30,31,41, 46,47,48,49,59, 60,61,62	18-7750-1	18-7211-1	—	18-72000
75 (4 Stroke)	S/N OG960500-Up	—	18-7743	—	—	—
80 (3 cyl.)	S/N A996142-Up	WME-1,1A,1B,4,5, 6,6A,7,7B,8,9,10, 10A,15,15A,17,18, 19,25,29,30,31,41, 46,47,48,49,59, 60,61,62	18-7750-1	18-7211-1	—	18-72000
80 (4 cyl.)	1960-61	KD-4A	18-7013	18-7006-1	18-7061	18-7208
80 (4 cyl.)	1969-72	WMK-2	18-7021	18-7006-1	18-7061	18-7208
80 (4 cyl.)	1978-83	WM-5,10,12, 14, 17	—	18-7004	18-7061	18-7249
80 800 (6 cyl.)		KA-10A, 11A, 14A, 16A, KC-3A	—	18-7006-1	18-7057	18-7208
Jet 80 (4 cyl.)	S/N B209468-Up	WME-11,14,20,20A, 21,21A,32,32A,33, 34,40,40A,50,51,52,79	18-7750-1	18-7211-1	—	18-72000
85	1973-75	WMK-4,WMK-16, WMK-17	18-7021	18-7006-1	18-7061	18-7208
85 850 (6 cyl.)	1963-65	KA,KC	18-7013	18-7006-1	18-7057	18-7208
85	1976-77	WM-3,WM-5	—	18-7004	18-7061	18-7249
90 (3 cyl.)	S/N A996142-Up	WME-1,1A,1B,4,5,6, 6A,7,7B,8,9,10,10A, 15,15A,17,18,19,25, 29,30,31,41,46,47, 48,49,59,60,61,62	18-7750-1	18-7211-1	—	18-72000
90 (4 Stroke)	S/N OG960500-Up	—	18-7743	—	—	—
90 (6 cyl.)	1965	KC-6A	18-7013	18-7006-1	18-7057	18-7208
90 (6 cyl.)	1978-86	WMK-23,WMK-27, WMK-30,WMK-35, WMK-39	18-7021	18-7006-1	18-7061	18-7208
95	1966-67	KC-6A	18-7013	18-7006-1	18-7057	18-7208
100 (4 cyl.)	S/N B209468-Up	WME-11,14,20,20A, 21,21A,32,32A,33,34,	—	—	—	—

APPLICATION CONTINUED ON NEXT PAGE

MERCURY CARBURETOR KIT APPLICATION (Cont.)

HP	Year — S/N	Carburetor Model	Carburetor Kit	Gasket Kit	Needle & Seat	Float
		40,40A,50,51,52,79	18-7750-1	18-7211-1	—	18-72000
100 (6 cyl.)	1962-69	KC-1A,7A,10A,14A	18-7013	18-7006-1	18-7057	18-7208
100 (6 cyl.)		KD-1A, 1B, 2A, 3A	18-7013	18-7006-1	18-7061	18-7208
V-105 Jet	1994-95 S/N OD082000-OG303045	WMH-13, 13B, 23, 31	18-7355	18-7213	—	—
V-105 Jet	1996 & Up S/N OG303046 & Up	WMV-2, 2A	18-7356	18-7214	—	—
110		KC-1A, 7A, 7B, 10A, 14A	18-7013	18-7006-1	18-7057	18-7208
115 (4 cyl.)	S/N B209468-Up	WME-11,14,20,20A, 21,21A,32,32A,33,34, 40,40A,50,51,52	—	—	—	—
		40,40A,50,51,52	18-7750-1	18-7211-1	—	18-72000
115 (6 cyl.)	1970-77	KD-6A,KD-6B	18-7013	18-7006-1	18-7061	18-7208
115 (6 cyl.)	1970-88	WMK-3,10,15, 18, 26, 28, 32, 36, , 40, 41, 41-1A, 41-1B, 41-3A, 41-3B	18-7021	18-7006-1	18-7061	18-7208
125	1968-69	KD-1A,1B,2A, 3A	18-7013	18-7006-1	18-7057	18-7208
125 (4 cyl.)	S/N B209468-Up	WME-11,14,20,20A, 21,21A,32, 32A,33, 34,40,40A,50,51,52, 81	—	—	—	—
		40,40A,50,51,52, 81	18-7750-1	18-7211-1	—	18-72000
135	1970-71	KD-7A,KD-7B	18-7013	18-7006-1	18-7057	18-7208
135	1970-71	WMK-4	18-7021	18-7006-1	18-7061	18-7208
V-135	1986-88 S/N OA904646-OC100860	WH-33, 40	18-7354	18-7005	18-7233	—
V-135	1986-88 S/N OA904646-OC100860	WH-32, 35, 38	18-7354	18-7005	—	—
V-135	1989-90 S/N OC100861-OC239552	WH-35, 38	—	18-7005	18-7233	—
V-135	1989-90 S/N OC100861-OC239552	WH-40, 48	18-7354	18-7005	18-7233	—
V-135	1991 S/N OC239553-OD081999	WMH-8, 8A	18-7355	18-7213	—	—
V-135	1992-95 S/N OD082000-OG303045	WMH-12A, 12B, 28, 30	18-7355	18-7213	—	—
V-135	1996-98 S/N OG303046-OG760299	WMV-1, 1A	18-7356	18-7214	—	—
V-135	1999 & Up S/N OG760300 & Up	WMV-1A, 15, 15A	18-7356	18-7214	—	—
140	1972	WMK-7,WMK-9	18-7021	18-7006-1	18-7061	18-7208
140	1978-80	WMK-25,WMK-29	18-7021	18-7006-1	18-7061	18-7208
V-140 Jet	1994-95 S/N OG082000-OG303045	WMH-16, 21, 34, 39	18-7355	18-7213	—	—
V-140 Jet	1996-98 S/N OG303046-OG760299	WMV-5, 5A	18-7356	18-7214	—	—
V-140 Jet	1999 & Up S/N OG760300 & Up	WMV-5A	18-7356	18-7214	—	—
150	1973-77	WMK-11	18-7021	18-7006-1	18-7061	18-7208
150	1973-78	WMK-14,WMK-19, WMK-22	—	—	—	—
		WMK-22	18-7021	18-7006-1	18-7061	18-7208
3.4L	1984-86	WO-3	—	—	18-7233	—
V150	1978-90	WH-2,12,21,23,27, 29,35,38,40,48	—	18-7005	18-7233	—
V-150	1979-85 S/N OA904645 & Below	WH-9	—	18-7005	—	—
V-150	1979-85 S/N OA904645 & Below	WH-12	—	18-7005	18-7233	—
V-150	1979-85 S/N OA904645 & Below	WH-29	18-7354	18-7005	18-7233	—
V-150	1986-90 S/N OA904646-OC239552	WH-35, 38	—	18-7005	18-7233	—
V-150	1986-90 S/N OA904646-OC239552	WH-40, 48	18-7354	18-7005	18-7233	—
V-150	1990-91 S/N OC239553-OD081999	WMH-1, 7	18-7355	18-7213	—	—
V-150	1992-95 S/N OD082000-OG303045	WMH-13, 13B, 23, 31	18-7355	18-7213	—	—
V-150	1996-98 S/N OG303046-OG760299	WMV-2, 2A	18-7356	18-7214	—	—
V-150	1999 & Up S/N OG760300 & Up	WMV-3A, 16, 16A	18-7356	18-7214	—	—
V-150 (XR4, MAGII)	1988 S/N OB242885-OC100860	WH-41A	18-7354	18-7005	18-7233	—
V-150 (XR4, MAGII)	1989 S/N OC100861-OC239552	WH-41	18-7354	18-7005	18-7233	—
V-150 (XR4, MAGII)	1989 S/N OC100861-OC239552	WH-41A	18-7354	18-7005	18-7233	—
V-150 (XR4, MAGII)	1990-91 S/N OC239553-OD081999	WMH-6	18-7355	18-7213	—	—
V-150 (XR6, MAGIII)	1996-98 S/N OG303046-OG760299	WMV-3, 3A	18-7356	18-7214	—	—
V-150 (XR6, MAGIII)	1999 & Up S/N OG760300 & Up	WMV-3A, 16, 16A	18-7356	18-7214	—	—
V-150 (XR6, MAGIII)	1992-95 S/N OD082000-OG303045	WMH-14A, 25, 32A	18-7355	18-7213	—	—
V-175	1976-88 S/N 4301235-OC100860	WH-1, 4, 7, 7A, 13, 17, 28, 39, 46	—	18-7005	18-7233	—
V-175	1976-88 S/N 4301235-OC100860	WH-17R, 30, 34	18-7354	18-7005	18-7233	—
V-175	1990 S/N OC100861-OC239552	WH-34	18-7354	18-7005	18-7233	—
V-175	1991 S/N OC239553-OD081999	WMH-2, 11	18-7355	18-7213	—	—
V-175	1992-95 S/N OD082000-OG303045	WMH-15, 22, 33	18-7355	18-7213	—	—
V-175	1996-98 S/N OG303046-OG760299	WMV-4, 4A	18-7356	18-7214	—	—
V-175	1999 & Up S/N OG760300 & Up	WMV-4A	18-7356	18-7214	—	—
V200	1978-90 □	WH-3,14,18,20, 22,26,28,31,39,46	—	18-7005	18-7233	—
V-200	1991 S/N OC291520-OD081999	WMH-3	18-7355	18-7213	—	—
V-200	1992-95 S/N OD082000-OG303045	WMH-16, 21, 34, 39	18-7355	18-7213	—	—
V-200	1996-98 S/N OG303046-OG760299	WMV-5, 5A	18-7356	18-7214	—	—
V-200	1999 & Up S/N OG760300 & Up	WMV-5A	18-7356	18-7214	—	—
V200	1980-82 S/N 4839034-OC100860	WH-3A, 11	—	18-7005	—	—
V-225 (2.4L)	1981 & Up 5628028 & Up	WH-5, 20	—	18-7005	18-7233	—
V225	S/N D280813 thru G303045	WMH-19,45,46,47	18-7355	18-7213	—	—
V225	1980-81	WH-15	—	18-7005	18-7233	—
V-225 (3.0L)	S/N OD280813-OG303045	WMH-19, 46, 47	18-7355	18-7213	—	—
V-225 (3.0L)	S/N OG303046-OG760299	WMV-7, 13	18-7356	18-7214	—	—
V-225 (3.0L)	S/N OG303046 & Up	WMV-13, 13A	18-7356	18-7214	—	—
V-225 (3.0L)	S/N OG245605-OG303045	WMH-45	18-7355	18-7213	—	—
Seapro/Marathon V-225 (3.0L)	S/N OG303046-OG760299	WMH-6, 11A	18-7356	18-7214	—	—
Seapro/Marathon V-225 (3.0L)	S/N ALL & Up	WMV-11, 11A, 13, 13A, 19	18-7356	18-7214	—	—
V250	1989-90	WD-8A-1,2,3,4,5,6	—	—	18-7061	—
V275	1989-91	WD-9/9A-1,2,3,4,5,6	—	—	18-7061	—
V300	1980 & Up S/N 5611648 & Up	WD-3, 5	—	—	18-7061	—
XR2	S/N C239553-Up	WHM-1,2,3B,5,7,8, 8A,11A,12,12A,12B, 13,13B,14A,15,16, 18A,21,22,23,24,25, 28,30,31,32,33,34	—	—	—	—
		28,30,31,32,33,34	18-7213	—	—	—
XR4	1988-90	WH-41,WH-41A	—	18-7005	—	—
XR6/ MAGIII	S/N C239553-Up	WHM-1,2,3B,5,7,8, 8A,11A,12,12A,12B, 13,13B,14A,15,16, 18A,21,22,23,24,25, 28,30,31,32,33,34	—	—	—	—
		28,30,31,32,33,34	18-7213	—	—	—

① Except EFI, XRI

 <p>18-8957 CHECK VALVE Replaces: 22-8189941, 22-818994</p>	 <p>PKG. OF 2 18-8956 COUPLER Couples 3/8" to 5/16" Hose Replaces: 22-8M0001721</p>	 <p>18-8958 FITTING Replaces: 22-424254</p>	 <p>18-8866 FUEL PUMP Replaces: 899106T01, 892874T01 Fits: Mercury 4 stroke outboard</p>
 <p>18-7804 FUEL PUMP KIT Replaces: 23014A1</p>	 <p>18-7806-1 FUEL PUMP KIT</p>	 <p>18-7807 FUEL PUMP KIT Replaces: 55278A1</p>	 <p>18-7808 FUEL PUMP KIT Replaces: 55278A5</p>
 <p>18-7809 FUEL PUMP KIT Replaces: 55278A4, 55278A3</p>	 <p>18-7810 FUEL PUMP KIT Replaces: 90363A1</p>	 <p>18-7811 FUEL PUMP KIT Replaces: 89031A1, 66599A1</p>	 <p>18-7812 FUEL PUMP KIT Replaces: 89031A2, 66599A2</p>
 <p>18-7813 FUEL PUMP KIT Replaces: 89031A3, 66599A3</p>	 <p>18-7814 FUEL PUMP KIT Replaces: 89031A4</p>	 <p>18-7817 FUEL PUMP KIT Replaces: 21-42990A7, A8, A9, A10, 21-857005A1</p>	 <p>18-7818-1 FUEL PUMP KIT Replaces: 42909A1, 42909A2, 42909A3, 42909A4</p>
 <p>18-7833 FUEL PUMP DIAPHRAGM Replaces: 11497M</p>	 <p>18-7834 FUEL PUMP DIAPHRAGM Replaces: 91748M</p>	 <p>18-7837 FUEL PUMP DIAPHRAGM Replaces: 84262M</p>	 <p>18-7838 FUEL PUMP DIAPHRAGM Replaces: 84265M</p>
 <p>18-7839 FUEL PUMP DIAPHRAGM Replaces: 80606M</p>	 <p>18-7840 FUEL PUMP DIAPHRAGM Replaces: 84141M</p>	 <p>18-7847 FUEL PUMP DIAPHRAGM</p>	

DIAPHRAGM APPLICATION ON NEXT PAGE

MERCURY FUEL PUMP KITS

HP	Beginning	Ending	Fuel Pump Kit	HP	Beginning	Ending	Fuel Pump Kit
7.5	3488153	& UP	18-7815 ②	115 (4 CYL)	B209468	& UP	18-7817 ⑦
8	A197112	& UP	18-7212	115 (115, 1150) SQUARE F/P	6436123	& UP	18-7817
9.8	3482753	& UP	18-7815 ②	115 (4 CYL)	D283222	& UP	18-7817
9.9	A197112	& UP	18-7212	115 (6 CYL) DFI	G960500	T178999	18-7817
10	1057994	1455239	18-7804	115 (3 CYL) DFI	T801000	& UP	18-7817
15	1200114	1349667	18-7804	115 PRO XS	B751825	& UP	18-7817
15	B292414	& UP	18-7212	120	ALL		18-7806-1
20	1866496	2296266	18-7804	120XR	ALL		18-7806-1
20	3537531	A910970	18-7815 ②	125 (1250) 6 CYL	2314956	2839386	18-7804
20	6443973	T800749	18-7212	125 (4 Cyl.)	D283222	& UP	18-7817
20 JET	G044027	& UP	18-7212	125 (1250BP) 6 CYL	2400058	2641954	18-7817
22	1158546	1499331	18-7804	125 (3 CYL) DFI	B736885	& UP	18-7817
25	1467499	1499331	18-7804	135	2839369	3293233	18-7807
25	6443973	& UP	18-7212	V-135	C100860	& Below	18-7812 ①
30	950250	1448139	18-7804	V-135	A904646	& UP	18-7817 ⑤
30 JET	C159200	T408999	18-7817	V-135 TRIANGULAR F/P	A904646	C100860	18-7813
35	6445652	& BELOW	18-7804	V-135 SQUARE F/P	A904646	D081999	18-7817
35	6445653	B110788	18-7809	V-135	D082000	T178499	18-7817
35	B110789	& UP	18-7817	V-135 DFI (DESIGN II)	G590000	G760299	18-7817
40 (2 cyl.)	831021	1476509	18-7804	V135 DFI	G760300	& UP	18-7817
40 (2 CYL)	2874704	5556229	18-7807	140	3293234	3502805	18-7807
40 (2 CYL)	C159200	& UP	18-7817	140	4865678	5327662	18-7811
40 (2 CYL)	G053314	& UP	18-7817	140 JET	ALL		18-7817
40 (3 CYL)	G590000	T999999	18-7817	150	3502806	4865677	18-7807
40 FOUR STROKE JET 2 CYCLE	G760300	& UP	18-7817	150 EFI	G303046	& UP	18-7817
45	1139538	1531958	18-7804	V-150	C100860	& Below	18-7812 ①
45 (4 cyl.)	B110789	& UP	18-7817	V-150	A904646	C100860	18-7817 ⑤
45/50 (4 cyl.)	3478003	B110788	18-7815 ②	V-150 XR2	ALL		18-7812
45 JET	6428681	& UP	18-7817	V-150 (150HP)	4868998	A904645	18-7812
45 JET	D000750	T129554	18-7817	V-150 SQUARE F/P	A904646	C100860	18-7817
50 (4 cyl.)	2116318	4357639	18-7804	V-150	C100861	D081999	18-7817
50 (3 cyl.)	6428681	B122929	18-7809	V-150 CARB & EFI	D082000	B226999	18-7817
50 (3 cyl.)	B122930	T999999	18-7817	V-150 DFI (DESIGN I)	G590000	G760299	18-7817
50/55 (3 cyl.)	D000750	& UP	18-7817	V-150 DFI (DESIGN II)	G590000	G760299	18-7817
60	1072997	1542744	18-7804	V-150 DFI	G760300	& UP	18-7817
60	6428681	B122929	18-7809	V-175	C100860	& Below	18-7812 ①
60 (3 cyl.)	B122930	& UP	18-7817	175 EFI	G303046	G589999	18-7817
60 (3 cyl.)	D000750	& UP	18-7817	V-175	6618751	& UP	18-7817 ⑤
65	1542745	2803561	18-7804	V-175 TRIANGULAR F/P	4301235	C100860	18-7812
65	ALL 3 CYL		18-7807	V-175 SQUARE F/P	4301235	& UP	18-7817
65 JET	D283222	& UP	18-7817	V-175	C100861	D303045	18-7817
65 (650) 4 CYL	2119749	2803561	18-7804	V-175	D303046	G960499	18-7817
70	1143038	1566239	18-7804	V-175 EFI	D000750	D081999	18-7817
70 (3 cyl)	4571652	6428680	18-7809	V-175 EFI	D082000	T408999	18-7817
70 (3 cyl)	A996142	C221999	18-7818-1	V-175 EFI	T409000	T800999	18-7817
75 (4 CYL) SQUARE F/P	6432901	& UP	18-7817	V-175 DFI	T178500	& UP	18-7817
75 (3 CYL) 90 DEGREE OIL CHECK VALVE	C222000	D283221	18-7818-1	V-175 PRO XS	B516339	& UP	18-7817
75 (3 CYL) INLINE OIL CHECK VALVE	C222000	D283221	18-7817	200 EFI	G303046	G589999	18-7817
75 (3 CYL)	D283222	& UP	18-7817	V-200	6073192	6357229	18-7810
75 (3 CYL) DFI	T980000	& UP	18-7817	V-200	6357230	6625220	18-7814 ①
75 (4 cyl.)	6432901	& UP	18-7808 ①	V-200	4839034	6073191	18-7812
75 (4 cyl.)	6432901	& UP	18-7817 ⑤	V-200	6625221	& UP	18-7817 ⑤
75 (3 cyl.)	A996142	D283221	18-7818-1	V-200	6625221	C291519	18-7817
80	1335465	2670574	18-7804 ③	V-200	C291520	B226999	18-7817
80	2783253	2856331	18-7807 ③	V-200 EFI	C100861	D081999	18-7817
80	2559001	2670574	18-7808 ④	V-200	D082000	T408999	18-7817
80	4831999	6432900	18-7808	V-200 (2.5L) EFI	T409000	& UP	18-7817
80 (3 CYL)	A966142	C221999	18-7818-1	V-200 (3.0L) EFI	T750164	& UP	18-7817
80 JET (3 CYL)	0D283222	& UP	18-7817	V-200 DFI	G590000	T598999	18-7817
80 JET (4 CYL)	B586067	& UP	18-7817	V-200 DFI	T599000	T5800999	18-7817
85	1460999	1766823	18-7804	V-200 DFI	T801000	& UP	18-7817
85	3493913	4831998	18-7808	V-200 PRO XS	B504989	& UP	18-7817
90 (6 cyl.)	1766824	4845300	18-7804	V-220 LASER	B117316	& UP	18-7817
90 (6 CYL)	5299506	6436122	18-7811 ①	V-225	5628028	& UP	18-7810
90 (6 CYL)	6436123	& UP	18-7817 ⑤	V-225 SEA PRO/MARATHON (3.0L)	D208813	& UP	18-7817
90 (3 CYL)	A996142	D283221	18-7818-1	V-225 (3.0L) EFI	G129222	& UP	18-7817
90 (3 CYL) INLINE OIL CHECK VALVE	C222000	D283221	18-7817	V-225 (3.0L) DFI	G590000	T598999	18-7817
90 (3 CYL) 90 DEGREE OIL CHECK VALVE	C222000	D283221	18-7818-1	V-225 DFI	T599000	T800999	18-7817
90 (3 CYL)	D283222	& UP	18-7817	V-225 DFI	T801000	& UP	18-7817
90 (3 CYL) DFI	T801000	& UP	18-7817	V-225 DTS	T599000	B417701	18-7817
95 (950) 6 CYL	1869776	2318585	18-7804	V-225 DTS	B417702	& UP	18-7817
95XR	ALL		18-7806-1	V-225 PRO XS	B104549	& UP	18-7817
100	2318586	3253111	18-7804	V-250 (3.4L)	C101891	& UP	18-7817
100 (4 CYL) 90 DEGREE OIL CHECK VALVE	B209468	D283221	18-7818-1 ⑥	V-250 (3.0L) EFI	G129222	& UP	18-7817
100 (4 CYL) INLINE OIL CHECK VALVE	B209468	D283221	18-7817 ⑦	V-250XB	G980600	T800999	18-7817
100 (4 CYL)	D283222	G965520	18-7817	V-250 DFI	B528615	& UP	18-7817
105 JET	ALL		18-7817	V-250 PRO XS	B426561	& UP	18-7817
110	1870204	2314955	18-7804	V-275 (3.4L)	C101891	& UP	18-7817
115	3761034	& BELOW	18-7807	V-300 (3.4L)	5611648	& UP	18-7812
115 (6 CYL)	5314656	6436122	18-7813 ①	XR4/XR6	C100860	& Below	18-7817
115 (6 CYL) TRIANGULAR F/P	6436123	& UP	18-7817 ⑤	Magnum II	ALL		18-7817
115 (4 CYL)	B209468	& UP	18-7818-1 ⑥				

① Except models with square fuel pump
 ② Models equipped with Tillotson BA, BB, BD carburetors
 ③ Dual fuel pump applications

④ Single fuel pump applications
 ⑤ Models with square fuel pumps

⑥ Use with white fuel pump body
 ⑦ Use with black fuel pump body

MARINER DIAPHRAGMS (Japanese Models)

Model	S/N Code	S/N	Diaphragms	Model	S/N Code	S/N	Diaphragms
5C	6E3	ALL	18-7834	28	644	M-664-151346 & UP	②
6C	6H8	ALL	18-7833	30	689	ALL	②
6D	6H6	ALL	18-7833	40 TC	6E9	ALL	②
8B	677	ML-677-316416 & UP	18-7837	40A APE	676	M-676-A00346 — 001990	18-7839
8B	677	M-677-012921 & UP	18-7837	40A APE	676	M-676-A001991 & UP	②
8C	6G1	ALL	18-7833	40A APE	676	ML-676-A41356 — 302250	18-7839
9.9C	682	ALL	①	40A APE	676	ML-676-A302251 & UP	②
15A	651	ALL	18-7839	40A APE	676	E-676-A10121 — 100355	18-7839
15C	684	ALL	①	40A APE	676	E-676-A100356 & UP	②
20A APE	653	ALL	18-7839	40A APE	676	EL-676-A50631 — 400940	18-7839
20C TPE	6A9	ALL	②	40A APE	676	EL-676-A400941 & UP	②
25A	648	EL-648-550230 & BELOW	18-7839	40B TPE	676	ALL	②
25A	648	EL-648-550231 & UP	②	40C TC	6E9	ALL	②
25A	648	E-648-26825 & BELOW	18-7839	48	670	ML-670-302510 & BELOW	18-7839
25A	648	E-648-26826 & UP	②	48	670	ML-670-302511 — 311995	②
25A	648	ML-648-304174 & BELOW	18-7839	48	670	M-670-02640 & BELOW	18-7839
25A	648	ML-648-304174 & UP	②	48	670	M-670-02641 — 002160	②
25A	648	M-648-19025 & BELOW	18-7839	W48	670	ML-670-311996 & UP	18-7839
25A	648	M-648-19026 & UP	②	W48	670	M-670-002161 & UP	18-7839
25C TPE	695	EL-695-550101 — 555959	②	55	663	EL-663-315379 — 317710	18-7839
25C TPE	695	EL-695-555960 & UP	18-7839	55	663	EL-663-317711 & UP	②
25C TPE	695	E-695-250101 — 253861	②	55	663	E-663-004041 — 004317	18-7839
25C TPE	695	E-695-253862 & UP	18-7839	55	663	E-663-004318 & UP	②
25C TPE	695	ML-695-300101 — 318173	②	55	663	ML-663-36475 & BELOW	18-7839
25C TPE	695	M-695-318174 & UP	18-7839	55	663	M-663-02730 & BELOW	18-7839
25C TPE	695	M-695-000101 — 023895	②	W55	663	ML-663-578278 — 583880	18-7839
25C TPE	695	M-695-023896 & UP	18-7839	W55	663	ML-663-583881 & UP	②
28	644	EL-664-570795 & BELOW	18-7839	60 2 CYL	6F0	ALL	18-7839
28	644	EL-664-570796 & UP	②	60 2 CYL	675	EL-675-30101 — 300280	18-7839
28	644	E-664-270310 & BELOW	18-7839	60 2 CYL	675	EL-675-300281 — 304180	②
28	644	E-664-270311 & UP	②	60 2 CYL	675	EL-675-304180 & UP	18-7839
28	644	ML-664-451125 & BELOW	18-7839	60 2 CYL	675	E-675-00101 — 000180	18-7839
28	644	ML-664-451126 & UP	②	60 2 CYL	675	E-675-00181 — 001170	②
28	644	M-664-151345 & BELOW	18-7839	60 2 CYL	675	E-675-001171 & UP	18-7839

① Requires the use of both 18-7837 and 18-7838

② Requires the use of both 18-7839 and 18-7840

8' LENGTH COMPLETE FUEL LINE ASSEMBLIES



3/8"
FUEL LINE ASSEMBLY

18-8010EP-2 SILVERADO 4000 Premium



FUEL LINE ASSEMBLY COMPONENTS

8' LENGTH COMPLETE FUEL LINE ASSEMBLIES



3/8"
FUEL LINE ASSEMBLY

18-8012EP-2 SILVERADO 4000 Premium

OE# 32-858114Q08,
32-858114K08



FUEL LINE ASSEMBLY COMPONENTS

Has 1/4" NPT threaded fitting on engine end and 1/4" NPT threaded fitting on the tank end. Primer bulb is included in this 8ft. (2.44 m) assembly. Fits various applications using the older style twist type disconnects at the engine end and either a bayonet or thread-in fitting on the tank end.

8' LENGTH COMPLETE FUEL LINE ASSEMBLIES



3/8"
FUEL LINE ASSEMBLY

18-8024EP-2 SILVERADO 4000 Premium

OE# 32-858104Q08,
32-858104K08



FUEL LINE ASSEMBLY COMPONENTS

Has standard quick connect type fitting on engine end and 1/4" NPT threaded fitting on the tank end. Primer bulb is included in this 8 ft. (2.44 m) assembly.

Fits Force 40 HP and larger (1993 & Newer), Force 9.9/15/25HP (1998), and all Mercury/Mariner outboards using clip on type disconnect at engine ends and a tank with threaded fuel pickup fitting.

* Tanks and Engines for picture purpose only.

8' LENGTH COMPLETE FUEL LINE ASSEMBLIES

3/8"
FUEL LINE ASSEMBLY

18-8025EP-2 SILVERADO 4000 Premium

OE# 32-858105Q08,
32-858105K08



18-8068
18-8082
TANK CONNECTOR
(SOLD SEPARATELY)



18-8084
FUEL
CONNECTOR



18-8005EP-1
PRIMER
BULB

18-8076
FUEL
CONNECTOR



*

*

FUEL LINE ASSEMBLY COMPONENTS

Has standard quick connect type fitting on engine end and bayonet style fitting on the tank end. Primer bulb is included in this 8 ft. (2.44 m) assembly.
Fits Force 40 HP and larger (1993 & Newer), Force 9.9/15/25HP (1998) , and all Mercury/Mariner outboards using clip-on type disconnect at the engine end and an older style tank with bayonet type connection.

8' LENGTH COMPLETE FUEL LINE ASSEMBLIES

3/8"
FUEL LINE ASSEMBLY

18-8016EP-2 SILVERADO 4000 Premium

OE# 32-858109Q12,
32-858109K12



18-80402
TANK
CONNECTOR
(SOLD SEPARATELY)



18-8091
FUEL
CONNECTOR



18-8005EP-1
PRIMER
BULB

18-8076
FUEL
CONNECTOR



*

*

FUEL LINE ASSEMBLY COMPONENTS

Has double sealed quick connect type fitting on tank end and clip-on type quick connect on engine end. Primer bulb is included in this 8ft. (2.44m) assembly.
Fits Force 40 HP and larger (1993 & Newer), Force 9.9/15/25HP (1998) and all Mercury Mariner outboards using clip-on type disconnects at both tank and engine ends

* Tanks and Engines for picture purpose only.

PRIMER BULBS



18-8002EP-1
18-8002EP-1-10①
PRIMER BULB
1/4"

18-8005EP-1
18-8005EP-1-10①
PRIMER BULB
3/8"

18-8004EP-1
18-8004EP-1-10①
PRIMER BULB
5/16"

Replaces: 13330A3,
13330Q, 13330Q5
Large capacity bulb

Replaces: 89396A38,
89396Q38
Large capacity bulb

HOSE BARB APPLICATION



PART #	MERCURY OE #	BARB	NPT	CONN. TYPE
18-8054	22-63186	5/16"	1/8"	Male
18-8055	22-63187	5/16"	1/4"	Male
18-8073	-	3/8"	1/8"	Male
18-8074	-	3/8"	1/4"	Male



18-7599
FUEL LOCK

Protect your outboard from theft, disconnect fuel line and simply install fuel lock. Designed to fit clip on style fuel connectors. Fits: Johnson Evinrude, Mercury/Mariner, Yamaha and Honda.

① Discount shop pack of 10 - Priced per package



**18-7083
PRIMER BULB**

Replaces: 858763, 8168773, 8168772, 8168771, 816877, 684311
Fits: 30 2cyl(All), 30 JET 3cyl(All), 40 2cyl(All), 40 3cyl(All), 40 JET(All), 50 3cyl(G590000 & Up), 55 3cyl(G590000 & Up), 60 3cyl(G590000 & Up), 60 3cyl Bigfoot(All), 65 JET (All), 75 3cyl(D283222 & Up), 90 3cyl(D283222 & Up)



**18-80410-1
FUEL CONNECTOR**

Replaces: 22-13563T3
Female Hose connector
 $\frac{3}{8}$ "
Fits: 4/5 2-Stroke (1999 & Up)
 Mates with **18-80412**



**18-80412
FUEL CONNECTOR**

Replaces: 22-816856T2
Male Hose connector
 $\frac{5}{16}$ "
Fits: 100 4-cyl. (1988-99), 115 4-cyl. (1989 & up), 125 4-cyl. (1994 & up), 65 Jet (1994 & up), 75 3-cyl. (1987 & up), 80 Jet (1994 & up), 90 3-cyl. (1987 & up)
 Mates with **18-80410-1**



**18-8068
TANK CONNECTOR**
(1/4" NPT)
(Female)



**18-8069
FUEL CONNECTOR**
 $\frac{5}{16}$ "
Replaces: 22831Q3, 22831A3, 22831A4, 22831B3, 22831A1
 (Female)



**18-8070
FUEL CONNECTOR**
 $\frac{5}{16}$ "
Replaces: 30185A3, 30185Q3, 30185B3, 30185A1, 29196, 16610M
 (Male)



**18-8075
FUEL CONNECTOR**
(1/4")
Replaces: 22-14213M, 2214213Q, 22-81042M
 Mates with **18-8077-1**



**18-8076
18-8076-10^①
FUEL CONNECTOR**
(3/8")
Replaces: 22-13563A3, 22-13563Q3
 Mates with **18-8077-1**



**18-8077-1
18-8077-1-10^①
TANK CONNECTOR**
(1/4" NPT)
 Mates with **18-8075, 18-8076, 18-8085**



**18-8082
TANK CONNECTOR**
Mercury Straight Fitting
(1/4" NPT)
(Female)



**18-8083
FUEL CONNECTOR**
 $\frac{3}{8}$ "
(Female)



**18-8084
FUEL CONNECTOR**
 $\frac{3}{8}$ "
Replaces: 30185A3, 30185Q3, 30185B3, 30185A1, 29196, 22-16610M
 (Male)



**18-8085
18-8085-10^①
FUEL CONNECTOR**
(5/16")
 Mates with **18-8077-1**



**18-8091
FUEL CONNECTOR**
(3/8")
Replaces: 22-13563Q7, 22-13563T7, 22-13563A7
 22-13563A6
 Mates with **18-80402**



**18-80402
FUEL CONNECTOR**
(1/4" NPT)
 Mates with **18-8091**

^① Discount shop pack of 10 - Priced per package

**- UNIVERSAL DESIGN -
DIRECT REPLACEMENT FOR MERCURY AND YAMAHA
FUEL WATER SEPARATOR BRACKETS**

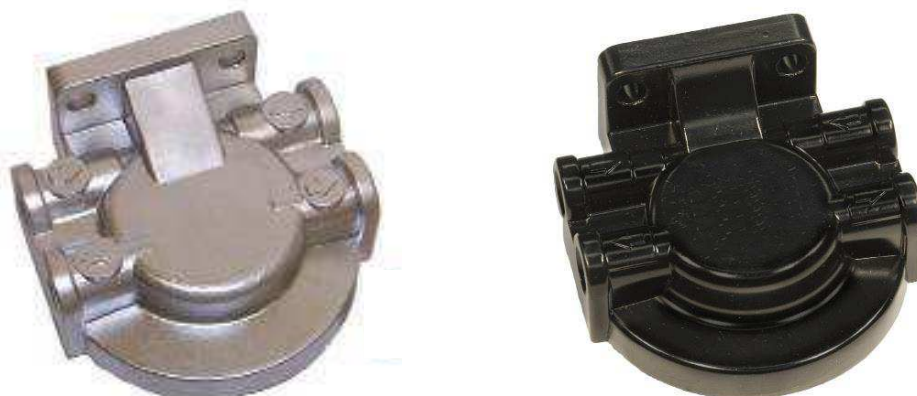

Bracket Type	Part #	Replaces	Bracket Type	Part #	Replaces
1/4" Stainless Steel	18-7777		1/4" Aluminum	18-7853-1	Mercury 89876A3, 89876, 55481
3/8" Stainless Steel	18-7776		3/8" Aluminum	18-7775	

FUEL WATER SEPARATOR KITS

**21 MICRON FILTER
KITS FOR
CARBURETED
ENGINES**



Kit Type	Part #	Micron Rating	Contents	Replaces
1/4" Aluminum (Short Filter)	18-7848-1	21	1 - 18-7844 filter & 1 18-7853-1 bracket 2 - 18-4256 1/4" pipe plugs	35-807172A4, Q4, 35-60494A4, 35-805369A4, 35-57250A1, 35-55501A1, 35-52456A1, 35-60494A1, 52444
1/4" Aluminum Bonus Pack Contains spare filter	18-7848-2	21	2 - 18-7844 filter & 1 18-7853-1 bracket 2 - 18-4256 1/4" pipe plugs	
1/4" Aluminum (Tall Filter)	18-7852-1	21	1 - 18-7845 filter & 1 18-7853-1 bracket 2 - 18-4256 1/4" pipe plugs	
1/4" Aluminum Bonus Pack Contains spare filter	18-7852-2	21	2 - 18-7845 filter & 1 18-7853-1 bracket 2 - 18-4256 1/4" pipe plugs	
3/8" Aluminum (Tall Filter)	18-7775-1	21	1 - 18-7845 filter & 1 18-7775 bracket 2 - 18-4264 3/8" pipe plugs	
1/4" Stainless Steel (Tall Filter)	18-7777-1	21	1 - 18-7845 filter & 1 18-7777 bracket 2 - 18-4256 1/4" pipe plugs	
3/8" Stainless Steel (Tall Filter)	18-7776-1	21	1 - 18-7845 filter & 1 18-7776 bracket 2 - 18-4264 3/8" pipe plugs	

• Display Packaged

10 MICRON FILTER KITS FOR FUEL INJECTED ENGINES

• Display Packaged



Kit Type	Part #	Micron Rating	Contents
1/4" Aluminum (Short Filter)	18-7983-1 •	10	1 - 18-7944 filter & 1 18-7853-1 bracket • 2 - 18-4256 1/4" pipe plugs
1/4" Aluminum Bonus Pack (Contains spare filter)	18-7983-2 •	10	2 - 18-7944 filter & 1 18-7853-1 bracket • 2 - 18-4256 1/4" pipe plugs
1/4" Aluminum (Tall Filter)	18-7982-1 •	10	1 - 18-7945 filter & 1 18-7853-1 bracket • 2 - 18-4256 1/4" pipe plugs
1/4" Aluminum Bonus Pack (Contains spare filter)	18-7982-2 •	10	2 - 18-7945 filter & 1 18-7853-1 bracket • 2 - 18-4256 1/4" pipe plugs
1/4" Aluminum (High Capacity Filter)	18-7966-1 •	10	1 - 18-7866 filter & 1 18-7853-1 bracket • 2 - 18-4256 1/4" pipe plugs
3/8" Aluminum (Tall Filter)	18-7986-1	10	1 - 18-7945 filter & 1 18-7775 bracket • 2 - 18-4264 3/8" pipe plugs
1/4" Stainless Steel (Tall Filter)	18-7984-1 •	10	1 - 18-7945 filter & 1 18-7777 bracket
3/8" Stainless Steel (Tall Filter)	18-7985-1 •	10	1 - 18-7945 filter & 1 18-7776 bracket • 2 - 18-4264 3/8" pipe plugs
1/4" Aluminum (Tall Filter)	18-79912	10	1 - 18-79911 & 1 - 18-7853-1



10 MICRON FILTER KITS WITH DRAIN BOWLS

Sierra AquaVue™ and metal bowl separator filters allow water to be drained from the filter to extend service life. Use the AquaVue™ bowl for outboard, above deck installations. USCG regulations require the use of the flame resistant metal bowl below deck.

Kit Type	Part #	Micron Rating	Contents
1/4" Aluminum w/ AquaVue™ bowl	18-7932-1 •	10	1 - 18-7919 filter & 1 18-7853-1 bracket 1 - 18-7922-1 AquaVue™ bowl 2 - 18-4256 1/4" pipe plugs
1/4" Aluminum w/ metal drain bowl	18-7951 •	10	1 - 18-7919 filter & 1 18-7853-1 bracket 1 - 18-7924 metal bowl 2 - 18-4256 1/4" pipe plugs
1/4" Stainless Steel w/ AquaVue™ bowl	18-7937-1 •	10	1 - 18-7919 filter & 1 18-7777 bracket 1 - 18-7922-1 AquaVue™ bowl 2 - 18-4256 1/4" pipe plugs
1/4" Stainless Steel w/ metal drain bowl	18-7938 •	10	1 - 18-7919 filter & 1 18-7777 bracket 1 - 18-7924 metal bowl 2 - 18-4256 1/4" pipe plugs

• Display Packaged

COMPACT BRACKET AND SEPARATOR KIT FOR SMALL OUTBOARDS AND FRESH WATER APPLICATIONS



18-7965-1 10 MICRON COMPACT SEPARATOR KIT

Contains:
1 - 18-7774 bracket
1 - 18-7865 filter



18-7774
COMPACT ALUMINUM BRACKET

REPLACEMENT FILTERS



UNIVERSAL DESIGN - DIRECT REPLACEMENT FOR MERCURY AND YAMAHA

10 MICRON REPLACEMENT FILTERS			10 MICRON REPLACEMENT FILTERS		
Part #	Description	Replaces	Part #	Description	Replaces
18-7944	Short - 3.875"	35-807172, 35-802893Q, 35-806771, 35-8053691, 35-805369, 35-604941, 35-60494, 35-57250, 35-55501, 35-52456,	18-79911	Long - 8.5"	35-8M0079962
18-7945	Long - 4.35"	35-802893Q, 35-806771, 35-8053691, 35-805369, 35-604941, 35-60494, 35-57250, 35-55501, 35-52456	21 MICRON REPLACEMENT FILTERS		
18-7866	High Capacity - 6"		18-7844	Short - 3.875"	35-807172, 35-807172, 35-806771,
18-7865	Compact 10 Micron		18-7845	Long - 4.35"	35-8053691, 35-60494A4, 35-604941, 35-57250, 35-55501
18-7967	Early model with sensor	35-18458Q3, 35-18458A3, 35-18458A2, 35-17808A1, 35-14571A1	 <p>18-8955 FUEL WATER SEPARATOR COVER Fits: 18-7944 & 18-7945 sized filter</p>		
18-7968	Late model with sensor	35-18458Q4, 35-184585			



10 MICRON REPLACEMENT FILTERS AND KITS WITH DRAIN BOWLS

(SEE CHART BELOW)

- Display Packaged

REPLACEMENT FILTERS			FILTER & BOWL KITS	
Part #	Description	Replaces	Part #	Description
18-7919	Spin on replacement	35-809097, 35-8M0103095 Racor S3213	18-7928-1	Filter & AquaVue™ Bowl Mercury Style Contains: 18-7919 filter, 18-7922-1 bowl
18-7920	Spin on replacement	35-809099 Racor S3214	18-7929	Filter & Metal Bowl Mercury Style Contains: 18-7919 filter, 18-7924 bowl
18-7948	Spin on replacement Fits - 320RRAC01	35-886638 Racor S3227	18-7969	Filter & Metal bowl Contains: 18-7948 filter, 18-7924 bowl
REPLACEMENT BOWLS			18-7994-1	Filter & AquaVue™ Bowl Contains: 18-7948 filter, 18-7922-1 bowl
Part #	Description			
18-7922-1	AquaVue™ Collection Bowl			
18-7924	Metal Collection Bowl			

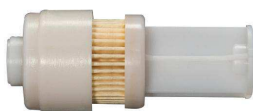

18-7936 FUEL FILTER ELEMENT
Replaces: 35-888289T2
Fits: 225 EFI (2003-06) (SN OT653945 & Up)



18-7712 FUEL FILTER (INLINE)
Replaces: 35-16248
Fits: 4/5 2 cyl (1999 & Up), 4/5/6 4 stroke (1999 & Up), 8/9.9 4-stroke (2005 & Up)



18-7713 FUEL FILTER (INLINE)
Replace: 35-80365M
Fits: Mercury/Mariner 9.9 4-Stroke(1995-98), 15 4-Stroke (1998 & Up), Yamaha 6 (1989, 1992-99), 8 (1989-99, 2001-02), F4 (1999-02), F9.9 (1989-95, 1997-99, 2001-02), FT 9.9 (1988-90)



18-7714 FUEL FILTER (INLINE)
Replaces: 35-877565T1
Fits: 25 4-Stroke (1998 & Up), 30 4-Stroke (1999-01), 30 3 cyl 4-Stroke (1999-01), 40 4-Stroke (1998-01), 40 4-Stroke 4 cyl (2001-02), 40 Carb 3-cyl 4-Stroke (2002 & Up), 50 4-Stroke 4 cyl (2001-02), 60 4-Stroke 4 cyl (2001-02), 75 4-Stroke (2000 & Up), 90 4-Stroke (2000 & Up)



18-7718 FUEL FILTER (INLINE) 5/16"
Replaces: 35-879885T
For: 135/150/175 4-Stroke Verado (S/N 1B227000 & Up), 200/225 4-Stroke Verado (S/N OT9800000 & Up), 250/275 4-Stroke Verado (S/N OT801000 & Up)



18-7802 FUEL FILTER
Replaces: 35-87946A3, 35-87946-Q3, Q4
For: 6 HP thru 25 HP



18-7832 FUEL FILTER
Replaces: 1399-3938, 1399-1754, 1399-1136
For: AJ, KA, KB, KC, KD, WM, WMC Carb.

18-7979 FUEL FILTER

Replace: 881540
Fits: 115 EFI (4 Stroke), 75HP (4 Stroke), 75HP (4 Stroke) (Bodensee), 90HP (4 Stroke)





**18-7981
FUEL FILTER**

Replaces: 35-884380T, 35-8M0020349
Fits: All Verados, 90HP (DFI) (3 cyl), 115 DFI (3 cyl) / 200HP (DFI) / 225HP (DFI) (including 3.0L DFI)

FUEL FILTERS



Part #	Application
18-7828-1	1/4" small capacity (For 1/4" fuel line)
18-7829	1/4" large capacity (For 1/4" fuel line) Replaces: 35-16494, 35-816296, 35-816296T, 35-816296K03
18-7830	5/16" Replaces: 35-164941, 35-816296-1, 35-816296T1, 35-8162961, 35-816396Q1 35-816296B2, 35-816296B1, 35-134301
18-7831	3/8" Replaces: 802128A1

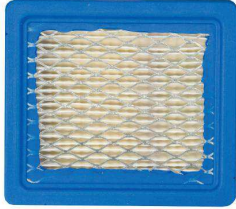

**18-7997
AIR FILTER**

Replaces: 35-853333T, 35-853333
Fits: V115 DFI (2.5L) (2000), V-135 DFI (2.5L) (1998 & Up), V-150 DFI (2.5L) (1998 & Up), V-175 DFI (2.5L) (2001 & Up), 200 DFI (1998-02), 225 DFI (1998-02)



**18-7999
AIR FILTER**

Replaces: 35-896247
For: 135/150/175 4-Stroke Verado (S/N 1B227000 & Up)

PKG. OF 10



**18-7113-9^②
O-RING**

Replaces: 25-897536, 25-98277
Fits: 18-7802 Filter Element (35-87946Q3)



**18-3605
THERMOSTAT KIT**

Fits: V-135 DFI (2.5L)(1998 & Up), V-150 DFI (2.5L)(1998 & Up), V-175 DFI (2.5L)(2000 & Up)

① 18-3606D



**18-3606
THERMOSTAT KIT 130°**

Fits: 200 3.0L DFI DTS (ALL), 200 3.0L EFI (2003 & Up) (OT750164 & Up), 200 DFI (1997 & Up)(OG386496 & Up), 225 3.0L EFI (1999 & Up)(OG760300 & Up), 225 3.0L EFI SeaPro (2004 & Up)(OT801000 & Up), 225 3.0L DFI DTS (2003 & Up)(OT599000 & Up), 225 DFI (1998 & Up) (OG590000 & Up), 250 3.0L EFI (1999 & Up) (OG760300 & Up), 250 Long 3.0L EFI (OT861319 & Up)



**18-43175
THERMOSTAT KIT 130°**

Replaces: 855676002
Fits: Mercury 15 Carb(2cyl) 4-Stroke(R235949& Up), 15 SeaPro 4-Stroke(R051685 & Up), 20 Carb(2cyl) 4-Stroke(R235168 & Up), 25 EFI(3cyl)4-Stroke(R106999 & Up), 25 Jet EFI(3cyl)4-Stroke(R165086 & Up), 25 SeaPro 4-Stroke(R051710 & Up), 30 EFI(3cyl)4-Stroke(T409000-1B226999), 8 4-Stroke(209cc)(R042475 & Up), 9.9 4-Stroke(209cc)(R042475 & Up)



**18-3672
THERMOSTAT KIT**

— CONTAINS —

Part #	Desc.	O.E. #
18-3553	Thermostat, Brass	75692
18-0182	Thermostat Gasket	27-62386

HP	Beg. S/N	End S/N	HP	Beg. S/N	End S/N
V135	A904646 & UP		V150 MAGII	C239553	4571651
V150	A904646 & UP		V150 MAGIII	D082000	4825248
V150 XR4	C239553	C159199	V175	C100861	& UP
V150 XR6	D082000 & UP		V200	6435503	& UP



**18-3569
THERMOSTAT KIT**

Replaces: 803061T1
Includes 18-3549 thermostat

HP	Beg. S/N	End S/N	HP	Beg. S/N	End S/N
70 3 cyl.	A996142	& UP	100 4 cyl.	B209468	& UP
75 3 cyl.	C222000	& UP	115 4 cyl.	C100000	& UP
80 3 cyl.	A996142	& UP	125 4 cyl.	D283222	& UP
90 3 cyl.	A996142	& UP			



**18-43052
THERMOSTAT KIT**

Replaces: 14586A3, 75962A9, 75962A10, 75962A11
Fits: Mercury 6-25 hp 2-Stroke



**18-3535
THERMOSTAT 130°**

Replaces: 885599004
Fits: 200 3.0L DFI DTS (ALL), 200 3.0L EFI (2003 & Up) (OT750164 & Up), 200 DFI (1997 & Up)(OG386496 & Up), 225 3.0L EFI (1999 & Up)(OG760300 & Up), 225 3.0L EFI SeaPro (2004 & Up)(OT801000 & Up), 225 3.0L DFI DTS (2003 & Up)(OT599000 & Up), 225 DFI (1998 & Up)(OG590000 & Up), 250 3.0L EFI (1999 & Up) (OG760300 & Up), 250 Long 3.0L EFI (OT861319 & Up)



**18-3536
THERMOSTAT 143°**

Replaces: 833072003
Fits: V135 DFI 2.5L (1998 & Up)(OG590000 & Up), V150 DFI 2.5L (1998 & Up)(OG590000 & Up), V175 DFI 2.5L (2001 & Up)(OT178500 & Up)



**18-3537
THERMOSTAT 143°**

Replaces: 833072002, 833072004
Fits: 75 3 cyl DFI 1.5L (2006 & Up)(OT980000 & Up), 90 3 cyl DFI 1.5L (2004 & Up)(OT801000 & Up) , 115 3 cyl DFI 1.5L (2004 & Up)(OT801000 & Up)

① Items ending in "D" are Display Packaged - Regular number is Non-Display

② Priced per package



18-3631
THERMOSTAT W/ HOUSING
Replaces: 892864T04
Fits: 135-300 Verado



18-3633
THERMOSTAT
Replaces: 8M0090819
Fits: 75-115HP, 115 Pro XS (2B094996 & Up)



18-3635
THERMOSTAT
Replaces: 892864T06
Fits: 75-115HP (1B366823-2B094995), 150 EFI (1B905505 & Up)



18-3638
THERMOSTAT
Replaces: 804540
Fits: 2.5-3.5HP (0R131842 & Up), 4-6HP (0R411838 & Up)



18-3640
THERMOSTAT
Replaces: 8M0117413
Fits: 40-60HP (1C050252 & Up)



18-3642
THERMOSTAT
Replaces: 855676A1
Fits: 40HP (3Cyl) (1C049739 & Up)



18-3553
THERMOSTAT
Replaces: 62981, 66850, 75692
143°

18-3553 THERMOSTAT APPLICATION

HP	Beg. S/N	End. S/N	HP	Beg. S/N	End. S/N
7.5	5226935	& UP	V150	A904646	& UP
9.8	5206550	& UP	V175	C100861	& UP
40	3336258	C159199	V200	6435503	& UP
50/60	D000750	& UP	V220	B117316	& UP
65	3547987	4571651	V225	5628028	& UP
70	4571652	4825248	V300/3.4L	5611648	& UP
70/75/80/90	A996142	& UP	XR4	C239553	D081999
100/115	B209468	& UP	Magnum II	C239553	D081999
V135	A904646	& UP			



18-3549
THERMOSTAT
Replaces: 14586
For: 6, 7, 8, 9.9 & 15 HP
Mercury/Mariner A197112 & Later
120°

18-3549 THERMOSTAT APPLICATION

MARINER		
HP	Serial #	
6,8,9.9 (2 cyl.)	A197112	Later
Sea Pro 10	D038000	Later
15 (2 cyl.)	B292414	Later
18XD, 20XD, 25XD	B114231	Later
25 (2 cyl.) 25 Sea Pro	B238464	Later
30 (2 cyl.)	G055314	Later
45 Jet, 50, 55, 60 (3 cyl.)	G290585	Later
MERCURY		
Sea Pro 10	D038000	Later
15 (2 cyl.)	B292414	Later
18XD, 20XD, 25XD	B114231	Later
25 (2 cyl.) 25 Sea Pro	B238464	Later
30 (2 cyl.)	G055314	Later
45 Jet, 50, 55, 60 (3 cyl.)	G290585	Later



18-3556
THERMOSTAT
Replaces: 895338
3/4" - 130°



18-43051
THERMOSTAT COVER KIT
Fits: Mercury V6



18-5896
SENDER
Replaces: 12415
1/8" - 27NPT Threads



18-3007
18-3007-10Ⓞ
IMPELLER
Replaces: 47-89983,
47-89983T



18-3008
IMPELLER
Replaces: 47-20813, 47-25287



18-3012
IMPELLER
Replaces: 47-22748



18-3017
18-3017-10①
IMPELLER
Replaces: 47-89984, 47-899842, 47-89984T3, 47-89984T4, 47-899844, 47-30221, 47-65960, 47-85460



18-3039
IMPELLER
Replaces: 47-65957, 47-89981, 47-39074
• .456" ID



18-3052
IMPELLER
Replaces: 47-56780, 47-65958, 47-89982



18-3054
IMPELLER
Replaces: 47-68988, 47-89980
• .438" ID



18-3056
18-3056-10①
IMPELLER
Replaces: 47-430261, 47-430262, 47-43026T2, 47-430264



18-3057
IMPELLER
Replaces: 47-85089-3



18-3062
IMPELLER
Replaces: 47-420381, 47-420382, 47-42038Q02



18-3063
IMPELLER
Replaces: 47-95611M, 47-81242M



18-3066
IMPELLER
Replaces: 47-11590M



18-3067
IMPELLER
Replaces: 47-84797M, 47-81604M



18-3069
IMPELLER
Replaces: 47-81423M, 47-97108M, 47-82824M



18-3072
IMPELLER
Replaces: 47-80395M



18-3073
IMPELLER
Replaces: 47-96305M































18-3074
IMPELLER
Replaces: 47-84027M, 47-84027T, 47-96619M



18-3098
IMPELLER
Replaces: 47-161543, 47-16154

APPLICATION BEGINS ON PAGE 399

① Discount shop pack of 10 - Priced per package

 <p>18-45312 IMPELLER Replaces: 47-95289, 47-952892 Fits: Mercury 2(T884302 & Up), 2.5(A855097 & Up), 3.3(G710613 & Up)</p>	 <p>18-8900 IMPELLER Replaces: 47-19453</p>	 <p>18-3293 IMPELLER KEY Replaces: 28-43037 Also large O/B's</p>	 <p>18-3294 IMPELLER KEY Replaces: 28-81603M</p>	
 <p>18-3300 IMPELLER KEY Replaces: 28-83444M For models: 40A, 40B, 40C</p>	 <p>18-3305 IMPELLER KEY Replaces: 28-81912M, 28-83701M For models: 6C-D, 8C, 9.9C, 15C</p>	 <p>NEW 18-1838 SEAL, SHORT (1 3/4") Replaces: 43023 25 (4-Stroke), 30 (2 Cyl.), 30 (4-Stroke), 40 (2 Cyl.), 40 (3 Cyl.), 40 (4-Stroke), 50 (3 Cyl.), 50 (4-Stroke), 50 Bigfoot (4-Stroke)</p>	 <p>NEW 18-1839 SEAL, LONG (2 1/4") Replaces: 8235471 25 (4-Stroke), 30 (2 Cyl.), 30 (4-Stroke), 40 (2 Cyl.), 40 (3 Cyl.), 40 (4-Stroke), 50 (3 Cyl.), 50 (4-Stroke), 50 Bigfoot (4-Stroke)</p>	
 <p>18-3109 WATER TUBE GUIDE Replaces: 23-29804, 23-29804T, 23-52928 (Use with 18-3116 Housing)</p>	 <p>18-3013 UPPER WATER PUMP SEAL Replaces: 26-821309 For: 4-Stroke O/B's, 25/30/40/45/50 HP s/n OG760300 & UP</p>	 <p>18-3110 WATER PUMP HOUSING WITH BUSHING Replaces: 26-38970, 26-36557A1, 26-29677 (Part of 18-3116 Housing)</p>	 <p>18-3014 LOWER WATER PUMP SEAL Replaces: 26-821310 For: 4-Stroke O/B's, 25/30/40/45/50 HP s/n OG760300 & UP</p>	 <p>18-3151 WATER COUPLING ASSEMBLY Replaces: 816597</p>
 <p>18-3154 WATER COUPLING ASSEMBLY Replaces: 826763A</p>	<p>PKG. OF 5</p>  <p>18-3227 18-3227-9^① WATER PUMP DOWEL PIN Replaces: 17-35973 For: 20-225HP S/N 1866496-Up</p>	 <p>18-1730 COUPLING Replaces: 43585 For: 200, 225, 250 & 275 Verado's</p>	 <p>18-3113 INSERT CUP Replaces: 70977</p>	 <p>18-3114 INSERT CUP Replaces: 48752, 48752T</p>
 <p>18-3115 INSERT CUP Replaces: 48753</p>	 <p>18-3435 INSERT CUP</p>	 <p>18-3107 IMPELLER PLATE Replaces: 54705, 32768</p>	 <p>18-3117 IMPELLER PLATE Replaces: 32435, 324351, 30605</p>	 <p>18-3122 IMPELLER PLATE Replaces: 817276, 8172761, 8172763</p>
 <p>18-3139 IMPELLER PLATE Replaces: 46895</p>	 <p>18-3436 IMPELLER PLATE</p>	<p>NEW</p>  <p>18-4577 WEAR PLATE Replaces: 8213542</p>	 <p>18-3116 WATER PUMP HOUSING Replaces: 46-96148, 46-96148A1, 46-96148T1, 46-64141A1, 46-48743A1</p>	 <p>18-3118 WATER PUMP HOUSING Replaces: 46-48746A1, 46-77822A1, 46-48746A3</p>

APPLICATION BEGINS ON PAGE 399



18-3414
WATER PUMP BASE
Replaces: 46-96146A5, 46-73804A1



18-3416
WATER PUMP BASE
Replaces: 46-96146A6, 46-96146A2, 46-78400A1, 46-73802A2



18-3419
WATER PUMP BASE
Replaces: 46-42579A3



18-3422
WATER PUMP BASE
Replaces: 46-77516A1, 46-73842A2, 46-68390A1, 46-65498A1, 46-48745A1



18-3423
WATER PUMP BASE
Replaces: 46-73640A1



18-3424
WATER PUMP BASE
Replaces: 46-77177A1



18-3445
WATER PUMP BASE
Replaces: 46-812966A7, 46-812996A3, 46-812996A9
For: 40-60 HP



18-43212
WATER PUMP HOUSING
Replaces: 46-803750A02, 46-8037502
Fits: Mercury 8/9.9 4-Stroke(209cc)



18-3207
IMPELLER REPAIR KIT
Replaces: 47-89983T2, 47-89983Q1

— CONTAINS —

Part #	Desc.	O.E. #	Qty.
18-3007	Impeller	47-89983	1
18-2945	Drain Gasket	12-20260,12-19183	2
18-2823	Low. Water Pump Base to Face Plate Gasket	27-32769, 27-19553	1
18-2824	Upper Face Plate to Pump Body Gasket	27-32770	1
18-2825	Water Pump Base Gasket	27-32771,27-19551	1
18-2841	Water Pump Base Gasket	27-77417,27-19552	1
18-2948	Rubber Washer	12-49221-1	1
18-3107	Plate	54705	1
18-7155	O-Ring	25-26855	1
18-7174	O-Ring	25-45711	1
18-7115	O-Ring	25-26722	1

18-3207D

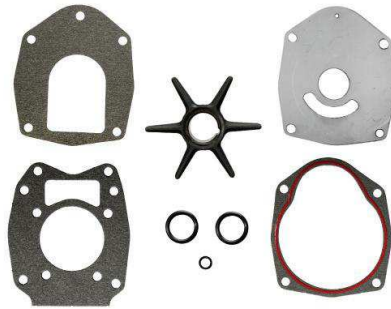

18-3214
IMPELLER REPAIR KIT
Replaces: 47-43026T6, 47-43026T8, 47-43026T11

— CONTAINS —

Part #	Desc.	O.E. #	Qty.
18-2564	Water Pump Base to Face Plate Gasket	27-43033-1	1
18-2565	Water Pump Base to Gear Housing Gasket	27-43047-1	1
18-2566	Face Plate to Water Pump Cover Gasket	27-817277	1
18-2944	Seal Ring	26-45577	1
18-3056	Impeller	47-43026-1	1
18-3122	Impeller Plate	817276	1
18-7420	O-Ring	25-21836	2

18-3214D



18-3215
IMPELLER REPAIR KIT
Replaces: 47-85089T7

— CONTAINS —

Part #	Desc.	O.E. #	Qty.
18-2560	Impeller Washer Gasket	12-86645	2
18-2561	Gear Housing to Face Plate Gasket	27-85087	1
18-2562	Gear Housing to Face Plate Gasket	27-99326-1	1
18-3057	Impeller	47-85089-3	1
18-7419	O-Ring	25-69202	1

18-3215D



18-3149-2
WATER PUMP KIT
Replaces: 46-42040A1, 46-42040A3, 46-42040A5, 46-42040T5
For: 10 Magnum, Marathon, Sea Pro, Viking
15 Marathon, Sea Pro 6, 8, 9.9HP, XR10

APPLICATION BEGINS ON PAGE 399

① Items ending in "D" are Display Packaged - Regular number is Non-Display



18-3265
IMPELLER REPAIR KIT

Replaces: 47-43026Q06, 47-43026T11, 47-8M0100526
For: 135/150/175 4-Stroke Verado (S/N 1B227000 & Up), 200/225 4-Stroke Verado (S/N OT980000 & Up), 250/275 4-Stroke Verado (S/N OT801000 & Up)



18-3217
IMPELLER KIT

Similar to: 46-96148A5 without base or housing

— CONTAINS —

Part #	Desc.	O.E. #	Qty.
18-3109	Water Tube	23-29804	1
18-3017	Impeller	47-89984	1
18-2919	Water Pump Gasket	27-42631-1	1
18-3110	Grommet	26-38970	1
18-2945	Drain Gasket	12-20260,12-19183	2
18-2826	Water Pump Base to Gear Housing Gasket	27-85610	1
18-2914	Water Pump Gasket	27-85608-1	1
18-2915	Water Pump Gasket	27-85609-1	1
18-2944	Seal Ring	26-45577	1
18-3117	Plate	32435	1
18-7158	O-Ring	25-30613	1
18-7162	O-Ring	25-33145	1
18-7173	O-Ring	25-30224	1
18-7176	O-Ring	25-90011	1
18-2801	Water Pump Gasket	27-32438	1
18-7426	O-Ring	35-30271	1



18-3239
IMPELLER REPAIR KIT

— CONTAINS —

Part #	Desc.	O.E. #	Qty.
18-3039	Impeller	47-89981	1
18-3139	Impeller Plate	46895	1
18-7409	O-Ring	—	1



18-3252
IMPELLER REPAIR KIT

Replaces: 47-89982T1

— CONTAINS —

Part #	Desc.	O.E. #	Qty.
18-2004	Oil Seal	26-20070	2
18-2006	Oil Seal	26-897154	1
18-2827	Upper Face Plate to Water Pump Body Gasket	27-39623	1
18-2828	Lower Water Pump Base to Face Plate	27-39625	1
18-3052	Impeller	47-89982	1
18-7164	O-Ring	25-33466	1



18-3406
UPPER WATER PUMP REPAIR KIT

Replaces: 817275A08
For: 135/150/175 4-Stroke Verado (S/N 1B227000 & Up), 200/225 4-Stroke Verado (S/N OT980000 & Up), 250/275 4-Stroke Verado (S/N OT801000 & Up)



18-3407
UPPER WATER PUMP REPAIR KIT

Replaces: 817275A09
For: 135/150/175 4-Stroke Verado (S/N 1B227000 & Up), 200/225 4-Stroke Verado (S/N OT980000 & Up), 250/275 4-Stroke Verado (S/N OT801000 & Up)

APPLICATION BEGINS ON PAGE 399

① Items ending in "D" are Display Packaged - Regular number is Non-Display

18-3314
WATER PUMP KIT

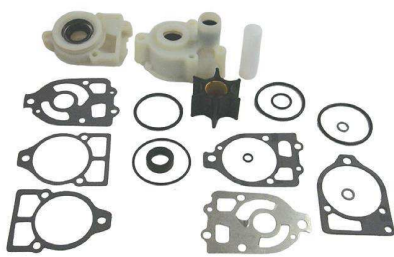

— CONTAINS —

Part #	Desc.	O.E. #	Qty.
18-3109	Water Tube Guide	23-29804	1
18-3017	Impeller	47-89984	1
18-3116	Housing	46-96148A1	1
18-3414	Base	46-96146A5	1
18-2919	Water Pump Gasket	27-42631-1	1
18-3110	Grommet	26-38970	1
18-2945	Drain Gasket	12-20260, 12-19183	2
18-2826	Water Pump Base to Gear Housing Gasket	27-85610-1	1
18-2914	Water Pump Gasket	27-85608-1	1
18-2915	Water Pump Gasket	27-85609-1	1
18-2944	Seal Ring	26-45577	1
18-3117	Plate	32435	1
18-7158	O-Ring	25-30613	1
18-7162	O-Ring	25-33145	1
18-7173	O-Ring	25-30224	1
18-7176	O-Ring	25-90011	1
18-2801	Gasket	27-32438	1
18-7426	O-Ring	35-30271	1

18-3316
WATER PUMP KIT

Replaces: 46-78400A2, 46-96148A8, 46-32437A3

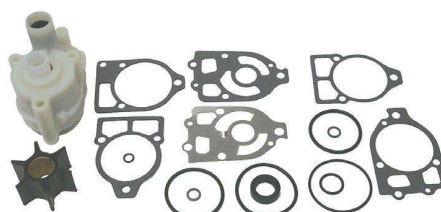

— CONTAINS —

Part #	Desc.	O.E. #	Qty.
18-3109	Water Tube Guide	23-29804	1
18-3017	Impeller	47-89984	1
18-3116	Housing	46-96148A1	1
18-3416	Base	46-96146A6	1
18-2919	Water Pump Gasket	27-42631-1	1
18-3110	Grommet	26-38970	1
18-2945	Drain Gasket	26-20260, 12-19183	2
18-2826	Water Pump Base to Gear Housing Gasket	27-85610-1	1
18-2914	Water Pump Gasket	27-85608-1	1
18-2915	Water Pump Gasket	27-85609-1	1
18-2944	Seal Ring	26-45577	1
18-3117	Plate	32435	1
18-7158	O-Ring	25-30613	1
18-7162	O-Ring	25-33145	1
18-7173	O-Ring	25-30224	1
18-7176	O-Ring	25-90011	1
18-2801	Gasket	27-32438	1
18-7196	O-Ring	25-38099	1
18-7426	O-Ring	35-30271	1

18-3319
WATER PUMP KIT

Replaces: 46-42579A4



— CONTAINS —

Part #	Desc.	O.E. #	Qty.
18-3109	Water Tube Guide	23-29804	1
18-3017	Impeller	47-89984	1
18-3116	Housing	46-96148A1	1
18-3419	Base	46-42579A3	1
18-2919	Water Pump Gasket	27-42631-1	1
18-3110	Grommet	26-38970	1
18-2945	Drain Gasket	26-20260, 12-19183	2
18-2826	Water Pump Base to Gear Housing Gasket	27-85610-1	1
18-2914	Water Pump Gasket	27-85608-1	1
18-2915	Water Pump Gasket	27-85609-1	1
18-2944	Seal Ring	26-45577	1
18-3117	Plate	32435	1
18-7158	O-Ring	25-30613	1
18-7162	O-Ring	25-33145	1
18-7173	O-Ring	25-30224	1
18-7176	O-Ring	25-90011	1
18-2801	Gasket	27-32438	1
18-7426	O-Ring	35-30271	1

18-3507
WATER PUMP KIT
(Without Base)

Replaces: 46-60366A1

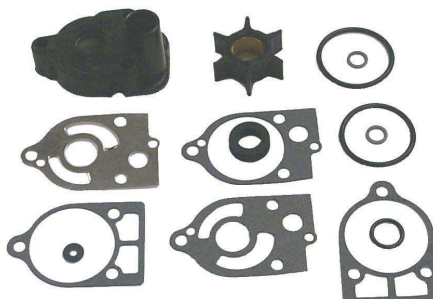

— CONTAINS —

Part #	Desc.	O.E. #	Qty.
18-3007	Impeller	47-89983	1
18-3118	Upper Pump Housing	46-77822A1	1
18-2945	Drain Gasket	12-20260, 12-19183	2
18-2823	Lower Water Pump Base to Face Plate Gasket	27-32769, 27-19553	1
18-2824	Upper Face Plate To Body Gasket	27-32770, 27-19551	1
18-2825	Water Pump Base Gasket	27-32771	1
18-2841	Water Pump Base Gasket	27-77417, 27-19552	1
18-2948	Drain Plug	12-49221-1	1
18-3107	Plate	54705	1
18-7155	O-Ring	25-26855	1
18-7174	O-Ring	25-45711	1
18-7115	O-Ring	25-26722	1

18-3517
WATER PUMP KIT
(Without Base)

Replaces: 46-96148A5, 46-96148A8, 46-78400A2, 46-73804A3
46-73802A3, 46-69222A3, 46-64141A11, 46-60367A4, 46-58618A4
46-57234A3, 46-48747A3, 46-42579A4, 46-44292A4, 46-32437A1



— CONTAINS —

Part #	Desc.	O.E. #	Qty.
18-3109	Water Tube	23-29804	1
18-3017	Impeller	47-89984	1
18-3116	Housing	46-96148A1	1
18-2919	Water Pump Gasket	27-42631-1	1
18-3110	Grommet	26-38970	1
18-2945	Drain Gasket	26-20260, 12-19183	2
18-2826	Water Pump Base to Gear Housing Gasket	27-85610-1	1
18-2914	Water Pump Gasket	27-85608-1	1
18-2915	Water Pump Gasket	27-85609-1	1
18-2944	Seal Ring	26-45577	1
18-3117	Plate	32435	1
18-7158	O-Ring	25-30613	1
18-7162	O-Ring	25-33145	1
18-7173	O-Ring	25-30224	1
18-7176	O-Ring	25-90011	1
18-2801	Water Pump Gasket	27-32438	1
18-7426	O-Ring	35-30271	1

18-3322
WATER PUMP KIT

Replaces: 46-77516A3



— CONTAINS —

Part #	Desc.	O.E. #	Qty.
18-3007	Impeller	47-89983	1
18-3118	Upper Pump Housing	46-77822A1	1
18-3422	Water Pump Base	46-77516A1	1
18-2945	Drain Gasket	12-20260, 12-19183	2
18-2823	Lower Water Pump Base to Face Plate Gasket	27-32769, 27-19553	1
18-2824	Upper Face Plate To Body Gasket	27-32770, 27-19551	1
18-2825	Water Pump Base Gasket	27-32771	1
18-2841	Water Pump Base Gasket	27-77417, 27-19552	1
18-2948	Drain Plug	12-49221-1	1
18-3107	Plate	54705	1
18-7155	O-Ring	25-26855	1
18-7174	O-Ring	25-45711	1
18-7115	O-Ring	25-26722	1

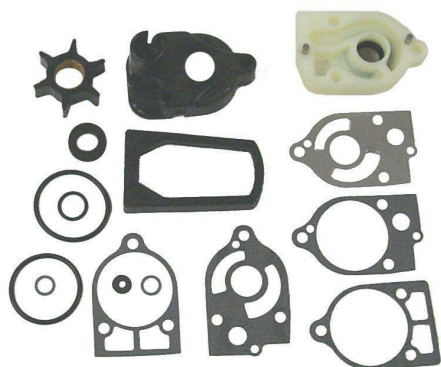

18-3323
WATER PUMP KIT
Replaces: 46-73640A2

— CONTAINS —

Part #	Desc.	O.E. #	Qty.
18-3007	Impeller	47-89983	1
18-3118	Upper Pump Housing	46-77822A1	1
18-3423	Water Pump Base	46-73640A1	1
18-2945	Drain Gasket.	12-20260, 12-19183	2
18-2823	Lower Water Pump Base to Face Plate Gasket	27-32769, 27-19553	1
18-2824	Upper Face Plate To Body Gasket	27-32770, 27-19551	1
18-2825	Water Pump Base Gasket	27-32771	1
18-2841	Water Pump Base Gasket	27-77417, 27-19552	1
18-2948	Drain Plug	12-49221-1	1
18-3107	Plate	54705	1
18-7155	O-Ring	25-26855	1
18-7174	O-Ring	25-45711	1
18-7115	O-Ring	25-26722	1

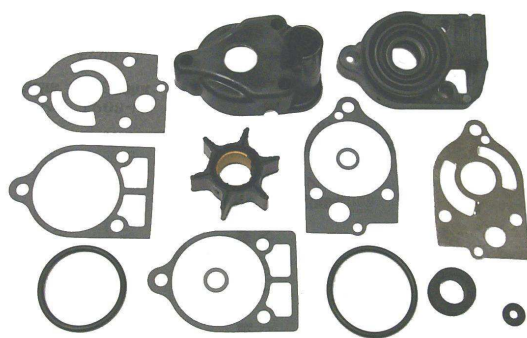

18-3324
WATER PUMP KIT
Replaces: 46-77177A3

— CONTAINS —

Part #	Desc.	O.E. #	Qty.
18-3007	Impeller	47-89983	1
18-3118	Upper Pump Housing	46-77822A1	1
18-3424	Water Pump Base	46-77177A1	1
18-2945	Drain Gasket.	12-20260, 12-19183	2
18-2823	Lower Water Pump Base to Face Plate Gasket	27-32769, 27-19553	1
18-2824	Upper Face Plate To Body Gasket	27-32770, 27-19551	1
18-2825	Water Pump Base Gasket	27-32771	1
18-2841	Water Pump Base Gasket	27-77417, 27-19552	1
18-2948	Drain Plug	12-49221-1	1
18-3107	Plate	54705	1
18-7155	O-Ring	25-26855	1
18-7174	O-Ring	25-45711	1
18-7115	O-Ring	25-26722	1

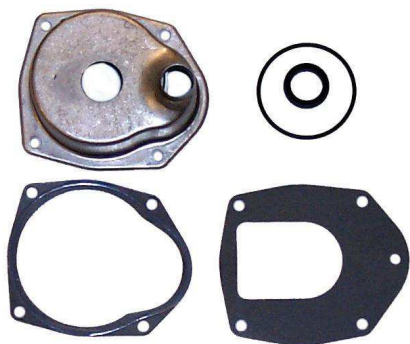

18-3571
WATER PUMP HOUSING KIT
Replaces: 817275A1
V-6 outboard



18-3572
WATER PUMP HOUSING KIT
Replaces: 46-43024A3, 817275A2



18-3148
WATER PUMP REPAIR KIT
Without Housing
Replaces: 46-84277M, 46-84277T

— CONTAINS —

Part #	Desc.	O.E. #	Qty.
18-0768	Wear Plate Gasket	—	1
18-3074	Impeller	47-84027M	1
18-3305	Woodruff Key	28-8192M	1



18-3446
WATER PUMP KIT
Replaces: 46-70941A3
For: 4/4.5 HP

— CONTAINS —

Part #	Desc.	O.E. #	Qty.
18-3039	Impeller	47-89981	1
18-3139	Impeller Plate	46895	1



18-3448
WATER PUMP KIT
Replaces: 46-48744A3
For: 20 HP 1967-80

— CONTAINS —

Part #	Desc.	O.E. #	Qty.
18-3052	Impeller	47-89982	1
18-2827	Upper Face Plate Gasket	27-39623	1
18-2828	Lower Face Plate Gasket	27-39625	1
18-2829	Water Pump Base Gasket	27-39626	1



18-4531
WATER PUMP REPAIR KIT
Without Housing

Replaces: 821354A2
Fits: 25 (4-Stroke), 30 (2 Cyl.), 30 (4-Stroke), 40 (2 Cyl.), 40 (3 Cyl.), 40 (4-Stroke), 50 (3 Cyl.), 50 (4-Stroke), 50 Bigfoot (4-Stroke)

— CONTAINS —

Part #	Desc.	O.E.#	Qty.
18-1838	Seal, Short 1 3/4"	43023	1
18-1839	Seal, Long 2 1/4"	8235471	1
18-2560	Washer	12-866451	2
18-0345	Gasket, Upper Water Pump	27-822189	1
18-99155	Gasket, Lower Water Pump	27-822217	1
18-4577	Plate, Wear	8213542	1
18-3057	Impeller	47-850893	1



18-3570
WATER PUMP KIT

— CONTAINS —

Part #	Desc.	O.E. #	Qty.
NSS	Water Pump Housing	—	1
18-3056	Impeller	47-430262	1
18-2599	Face Seal & Tool	26-816575A2	1
18-3122	Impeller Plate	817276	1

HP	Beg. S/N	End. S/N	HP	Beg. S/N	End. S/N
817275A2 APPLICATION					
817275A2 APPLICATION (Cont.)					
40 (4 stroke)			80 Jet	OD283222	& UP
(4 cyl.) Bigfoot	OT228405	& UP	90 (3 cyl.)	OA996142	& UP
50 (4 stroke)			90 (4 stroke)	OG960500	& UP
935cc Big Foot	OG231123	OT178499	100 (4 cyl.)	OB209468	& UP
50 (4 stroke)			115 (4 cyl.)	OC100000	& UP
996cc Big Foot	OT178500	& UP	125 (4 cyl.)	OD283222	& UP
60 (3 cyl.)			817275A1 APPLICATION		
Bigfoot	OD000750	& UP	45 (4 stroke)		
60 (4 stroke)			Bigfoot Bodensee	OG231123	& UP
Bigfoot	OT178500	& UP	V-200 DFI (3.0L)	OG386496	OG589999
65 Jet	OC283222	& UP	V-200 DFI (3.0L)	OG590000	& UP
70 (3 cyl.)	OA996142	& UP	V-225 (3.0L)		
75 (3 cyl.)	OC222000	& UP	Carb & EFI	OD280813	& UP
75 (4 stroke)	OG960500	& UP	V-225 DFI	OG590000	& UP
80 (3 cyl.)	OA996142	& UP	V-250 (3.0L) EFI	OG129222	& UP



18-3425
WATER PUMP KIT
Without Housing

Replaces: 84188M, 84188T

— CONTAINS —

Part #	Desc.	O.E.#	Qty.
18-0292	Wear Plate to Pump Housing Gasket	27-81417M	1
18-3435	Insert Cup	—	1
18-0294	Wear Plate to Pump Base Gasket	—	1
18-3069	Impeller	47-81423M, 47-97108M	1
18-0256	Bolt	—	2
18-3436	Impeller Plate	—	1
18-3297	Impeller Key	—	1

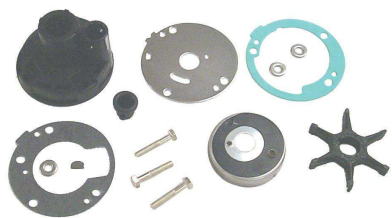

18-3426
WATER PUMP KIT
With Housing
Replaces: 42431M, 84829M, 97793M, 97793T

— CONTAINS —

Part #	Desc.	O.E.#	Qty.
18-3067	Impeller	47-84797M	1
18-3294	Impeller Key	28-81603M	1

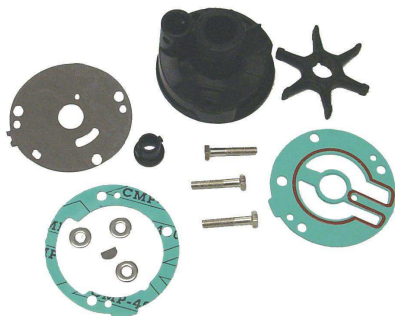

18-3427
WATER PUMP KIT
With Housing
Replaces: 81242M, 95661M

— CONTAINS —

Part #	Desc.	O.E.#	Qty.
18-0773	Wear Plate Gasket	—	1
18-3067	Impeller	47-84797M	1
18-3294	Impeller Key	28-81603M	1

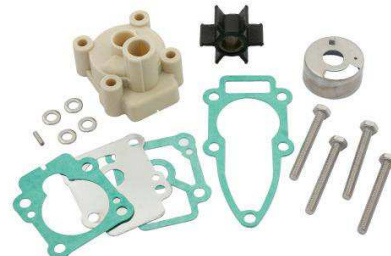

18-48317
COMPLETE WATER PUMP KIT

Replaces: 46-803750A03
Fits: Mercury 8-9.9 4-Stroke(209cc)(R042475 & Up)

MARINER COOLING SYSTEM APPLICATION

Mariner Models	S/N Code	S/N	Impeller	Plate	Impeller Cup	Impeller Repair Kit	Complete Kit
2A	646	All	18-3072	—	—	—	—
2B	6A1	All	18-3072	—	—	—	—
4A	6E0	All	18-3073	—	—	—	—
5C	6E3	All	18-3073	—	—	—	—
6C	6H8	All	18-3066	—	—	—	—
6D	6H6	All	18-3066	—	—	—	—
8A(M)	655	000000-000300	18-3063	—	—	—	—
8A(ML)	655	000000-300101	18-3063	—	—	—	—
8B(M)	677	000101 & Up	18-3063	—	—	—	—
8B(ML)	677	300101 & Up	18-3063	—	—	—	—
8C	6G1	All	18-3066	—	—	—	—
9.9C	682	All	18-3074	—	—	18-3148	—
15A(M)	651	000285 & Below	18-3063	—	—	—	—
15A(ML)	651	3000100 & Below	18-3063	—	—	—	—
15C	684	All	18-3074	—	—	18-3148	—
20C(M)	6A9	000101-005810	18-3067	18-3436	—	18-3426	—
20C(ML)	6A9	300101-306542	18-3067	18-3436	—	18-3426	—
20C(E)	6A9	250101-250819	18-3067	18-3436	—	18-3426	—
20C(EL)	6A9	550101-550693	18-3067	18-3436	—	18-3426	—
20C(M)	6A9	010112 & Up	18-3067	—	—	—	18-3427
20C(ML)	6A9	306543 & Up	18-3067	—	—	—	18-3427
20C(E)	6A9	250820 & Up	18-3067	—	—	—	18-3427
20C(EL)	6A9	550694 & Up	18-3067	—	—	—	18-3427
25C(M)	695	000101-014870	18-3067	18-3436	—	—	18-3426
25C(ML)	695	000000-312185	18-3067	18-3436	—	—	18-3426
25C(E)	695	000000-252290	18-3067	18-3436	—	—	18-3426
25C(EL)	695	000000-553575	18-3067	18-3436	—	—	18-3426
25C(M)	695	014871 & Up	18-3067	—	—	—	18-3427
25C(ML)	695	312186 & Up	18-3067	—	—	—	18-3427
25C(E)	695	252291 & Up	18-3067	—	—	—	18-3427
25C(EL)	695	553576 & Up	18-3067	—	—	—	18-3427
28	664	All	18-3067	—	—	—	—
30	689	All	18-3067	—	—	—	—
30A(M)	689	000366-014805	18-3067	18-3436	—	—	18-3426
30A(ML)	689	301911-315315	18-3067	18-3436	—	—	18-3426
30A(E)	689	100251-103275	18-3067	18-3436	—	—	18-3426
30A(EL)	689	401216-407815	18-3067	18-3436	—	—	18-3426
30A(M)	689	022059 & Up	18-3067	—	—	—	18-3427
30A(ML)	689	321377 & Up	18-3067	—	—	—	18-3427
30A(E)	689	105325 & Up	18-3067	—	—	—	18-3427
30A(EL)	689	411947 & Up	18-3067	—	—	—	18-3427
48/48W	670	All	18-3069	18-3436	18-3435	18-3425	—
55/W55	663	All	18-3069	18-3436	18-3435	18-3425	—
60	675,6F0	All	18-3069	18-3436	18-3435	18-3425	—

MERCURY COOLING SYSTEM APPLICATION

Horsepower	Beginning Serial #	Ending Serial #	Impeller	Impeller Plate	Insert Cup	Upper Housing	Base	Impeller Repair Kit	Thermostat	Upper Kit	Complete Kit
3.3 (with shift)	D901217	& UP	18-3098								
3.5	358136	6202172	18-3012								
3.5	6202173	& UP	18-3054								
3.6	5404657	& UP	18-3054								
3.9	14 1655013	2498135	18-3012	18-3139							
4 (1 cyl.)	2498136	4107219	18-3039	18-3139				18-3239			
4 (2 cyl.)	5589202	& UP	18-3054	—							
4 (made in USA)	5595532	A809600	18-3054	18-3139							
4 (made in USA)	5595532	& UP	18-3039	18-3139		18-3446		18-3239			18-3446
4 (1 cyl.)	A809601	& UP	18-3098						—		
4.5	4107220	5595531	18-3039	18-3139				18-3239			18-3446
4.5	5595532	& UP	18-3054	18-3139							
4.5	5595532	& UP	18-3039	18-3139				18-3239			18-3446
5	574128	786612	18-3012								
5 (1 cyl.)	A809601	& UP	18-3098								
5 4-STROKE	R000001	& UP	18-3098								
6	888005	1916138	18-3012								
6	1916139	2193817	18-3039	18-3139				18-3239			
6	A197112	OT800749	18-3062								
6	1582403	1916138	18-3039								
6	1916139	2193817	18-3039								
6	2193818	2529894	18-3039								
6	2385673	2387383	18-3039								
7.5	2529895	4131609	18-3039	18-3139							
7.5	4131610	5226934	18-3039	18-3139				18-3239			18-3446
7.5	5206550	& UP	18-3054								
7.5	5206550	& UP	18-3039	18-3139				18-3239			18-3446

- 1 Models with aluminum upper pump housings
- 2 Models with aluminum water pumps
- 3 Models with plastic upper pump housings
- 4 Models with plastic water pumps
- 5 Pump screws without insulators
- 6 Pump screws with insulators
- 7 Models with driveshaft retaining nut

- 8 Models without driveshaft retaining nut
- 9 Models with flush hole
- 10 Models without flush hole
- 11 Models having plastic upper housing use #48752 inset cup
- 12 Units already having a complete pump replacement using 46-46893A 6 should use the 2193818-2529894 serial group for components
- 13 Units already having a complete pump replacement using 46-46893A 6 should use USA 3795658-4126549 serial group for components
- 14 Units which have already had a complete pump replacement with the 46-46893A 6 pump should use the "Early Mariner Impellers" chart for components

MERCURY COOLING SYSTEM APPLICATION

Horsepower	Beginning Serial #	Ending Serial #	Impeller	Impeller Plate	Insert Cup	Upper Housing	Base	Impeller Repair Kit	Thermostat	Upper Kit	Complete Kit
8	A197112	& UP	18-3062								
8 (4-stroke Bodensee)	G760300	& UP	18-3062								
110 (9.8)	1865779	2196388	18-3039								
110 (9.8)	2196389	3795657	18-3039								
110 (9.8)	3795658	4126459	18-3039								
110 (9.8) 3	4126460	5206549	18-3039	18-3139				18-3239			
110	5206550	& UP	18-3054								—
9.8	5206550	& UP	18-3039	18-3139				18-3239	18-3553		18-3446
9.9	A197112	& UP	18-3062								
9.9 (4 Stroke) STANDARD CASE	G760300	T979999	18-3062								
XR10 SeaPro	D038000	& UP	18-3062						18-3549		
10	500022	1057993	18-3008								
15	B292414	& UP	18-3062						18-3549		
15 SeaPro	G044365	& UP	18-3062								
16	700000	& UP	18-3008								
18	5837437	& UP	18-3057								
20	860970	1292909	18-3008								
20	2827677	6443972	18-3052					18-3252			18-3448
20	6443973	T800749	18-3057					18-3215			
22	1158546	1238089	18-3008								
25,25XD,25 Sea Pro	5705532	& UP	18-3057					18-3215			
25 (3 cyl.)	E268781	& UP	18-3057					18-3215			
30	950250	1260724	18-3008					—			
30	1271884	1448139	18-3007	18-3107				18-3207		18-3507	—
30 Jet	C159200	G589999	18-3007	18-3107	18-3115	18-3118	18-3424	18-3207		18-3507	18-3324
30 Jet	G590000	& UP	18-3057								
30 (2 cyl)	G053314	T598999	18-3057								
35	1217222	1448139	18-3007	—	—	—	—	—	—	—	—
35	1571114	1960826	18-3007	18-3107				18-3207		18-3507	—
35	1960827	2453068	18-3007	18-3107				18-3207		18-3507	—
35	6445653	& UP	18-3007	18-3107	18-3115	18-3118	18-3424	18-3207		18-3507	18-3324
40	941751	1224480	18-3008	—	—	—	—	—	—	—	—
40	1224481	1476509	18-3007	—	—	—	—	—	—	—	—
40	2874704	4362214	18-3007	18-3107	18-3115	18-3118	18-3422	18-3207		18-3507	18-3322
40 (2 cyl) thru 1983	4860103	& UP	18-3057	18-3107	18-3115	18-3118	18-3424	18-3207		18-3507	18-3324
40 (3 cyl)	G531301	& UP	18-3057	—	—	—	—	—		18-3507	—
40 (4 cyl)	C159200	& UP	18-3007	18-3107	18-3115	18-3118	18-3424	18-3207			
40 (4-stroke) 2:1 ratio	G760300	T408999	18-3057								
40 (EFI 4-stroke) 1.83:1 ratio	T409000	& UP	18-8900				18-3445				
40 (EFI 4-stroke) 2.31:1 ratio	T409000	B344398	18-3056					18-3214			
40 (4-stroke, 4 cyl.) 2.31:1 ratio	T228405	T598999	18-3056					18-3214			
40 (4-stroke,Std)	G231123	T178499	18-3057								
40 4-stroke Carb BIG FOOT	C033811	& UP	18-3056								
40	1279685	1476509	18-3007							18-3507	
45	5531630	& UP	18-3007	18-3107	18-3115	18-3118	18-3424	18-3207			
45 Jet (3 cyl)	D000750	& UP	18-8900								
45 (4-stroke, std) Bodensee	G231123	& UP	18-3057								
45 (4-stroke, bigfoot) Bodensee	G231123	& UP	18-3056					18-3214			
50	1421113	1460498	18-3007							18-3507	
50	1477910	1521913	18-3007								
50	1521914	2305100	18-3007	18-3107				18-3207		18-3507	
50 aluminum w/p	2305101	2478119	18-3007								
50 plastic w/p	2305101	2478119	18-3007								
500	2514919	4357639	18-3007	18-3107	18-3115	18-3118	18-3422	18-3207		18-3507	
50 (4cyl)	4357640	5531629	18-3007	18-3107	18-3115	18-3118	18-3423	18-3207		18-3507	
50 (4cyl)	5531630	& UP	18-3007			18-3118					
50 (4 cyl)	4962056	& UP	18-3007	18-3107	18-3115	18-3118	18-3424	18-3207		18-3507	
50 (3 cyl)	6428681	D000749	18-3007	18-3107	18-3115	18-3118	18-3424	18-3207			
50 (3 cyl)	D000750	G589999	18-8900					18-3445	18-3553		
50 (3 cyl)	G590000	& UP	18-3057								
50 (4-stroke,Std)	G231123	T178499	18-3057								
50 (4-stroke, 4 cyl.) STANDARD	T178500	T598999	18-8900				18-3445				
50 (4-stroke, 4 cyl.) BIG FOOT	T178500	& UP	18-3056			18-3572		18-3214			
50 (EFI 4-stroke) STANDARD	T409000	B344398	18-8900				18-3445				
50 (EFI 4-stroke) BIG FOOT	T409000	B344398	18-3056					18-3214			
55 (3 cyl)	D000750	& UP	18-8900				18-3445				
60	6428681	D000749	18-3007	18-3107	18-3115	18-3118	18-3424	18-3207			18-3324
60 (3cyl) standard	D000750	& UP	18-3056	18-3122				18-3214	18-3553		
60 Marathon	D000750	& UP	18-3056	18-3122				18-3214			
60 Big Foot	D000750	& UP	18-3056	18-3122				18-3214	18-3553		
60 (3 cyl)	D000750	& UP	18-8900						18-3553		
60 4-STROKE STANDARD	OT178500	T598999	18-8900				18-3445	18-3214			
60 4-STROKE, BIG FOOT	OT178500	T598999	18-3056					18-3214			
60 4-STROKE EFI BIG FOOT	T409000	B344398	18-3056								

- 1 Models with aluminum upper pump housings
- 2 Models with aluminum water pumps
- 3 Models with plastic upper pump housings
- 4 Models with plastic water pumps
- 5 Pump screws without insulators
- 6 Pump screws with insulators
- 7 Models with driveshaft retaining nut

- 8 Models without driveshaft retaining nut
- 9 Models with flush hole
- 10 Models without flush hole
- 11 Models having plastic upper housing use #48752 inset cup
- 12 Units already having a complete pump replacement using 46-46893A 6 should use the 2193818-2529894 serial group for components
- 13 Units already having a complete pump replacement using 46-46893A 6 should use USA 3795658-4126549 serial group for components
- 14 Units which have already had a complete pump replacement with the 46-46893A 6 pump should use the "Early Mariner Impellers" chart for components

MERCURY COOLING SYSTEM APPLICATION											
Horsepower	Beginning Serial #	Ending Serial #	Impeller	Impeller Plate	Insert Cup	Upper Housing	Base	Impeller Repair Kit	Thermostat	Upper Kit	Complete Kit
65(4 cyl) aluminum w/p	1542745	280351	18-3017	18-3117	18-3114			18-3217		18-3507	
65 (4cyl) plastic w/p	1542745	280351	18-3017			18-3116					
65 (4cyl)	2803562	2874263	18-3017			18-3116					
65 (4cyl)	2997439	3293183	18-3017			18-3116					
65(3 cyl)	3293184	4382056	18-3007	18-3107	18-3115	18-3118	18-3422	18-3207		18-3507	
65(3 cyl)	4382057	4571651	18-3007	18-3107	18-3115	18-3118	18-3424	18-3207			
65 Jet	0D283222	& UP	18-3056	18-3122				18-3214			
70	1413611	1436114	18-3017	18-3117				18-3217		18-3507	
70 (6cyl)	1482212	1503458	18-3017								
700 E-2 (6cyl)	1503459	1503958	18-3017								
700 EL-2 (6cyl)	1503459	1566239	18-3017								
700 E-2 (6cyl) 11	1503959	1566239	18-3017			18-3116					
700 EL-2 (6cyl) 11	1505111	1566239	18-3017			18-3116					
70 (3 cyl)	4571652	4977156	18-3007	18-3107	18-3115	18-3118	18-3423	18-3207	18-3553	18-3507	
70	4977157	6428680	18-3007	18-3107	18-3115	18-3118	18-3424	18-3207			
70	B110054	& UP	18-3056					18-3214			18-3517
70 (3cyl) 6	A996142	C221999	18-3056			18-3572			18-3553		
70 (3cyl) 5	A996142	C221999	18-3056			18-3572			18-3553		
75 (4 cyl)	6432901	& UP	18-3017	18-3117	18-3114	18-3116	18-3414	18-3217			
75 (3 cyl)	A996142	C221999	18-3056					18-3214	18-3553		
75 (3 cyl)	C222000	& UP	18-3056					18-3214	18-3569		
75 (3 cyl)	C222000	& UP	18-3056	18-3122				18-3214	18-3569		
75 (3cyl) Optimax	T980000	& UP	18-3056			18-3572					
75 4-STROKE	G960500	B366822	18-3056					18-3214			
75 4-STROKE	B366823	& UP	18-3056			18-3572					
80	1355468	3493912	18-3017	18-3117				18-3217		18-3517	
80 (6cyl)	1335465	1398629	18-3017								
80 (4 cyl)	4831999	6432900	18-3017	18-3117	18-3114	18-3116	18-3414	18-3217			
80 (3 cyl) 6	A996142	C221999	18-3056					18-3214	18-3553		
80 (3 cyl) 5	A996142	C221999	18-3056			18-3572			18-3553		
80 Jet	D283222	& UP	18-3056	18-3122				18-3214			
850 E & EL (6cyl)	1460999	1567039	18-3017	18-3117				18-3217		18-3517	
850 E-1, EL-1 (6cyl) 11	1566240	1766823	18-3017								
85 (4 cyl)	4590512	& UP	18-3017	18-3117	18-3114	18-3116	18-3414	18-3217			
85 XS (4cyl)	3493913	4831998	18-3017			18-3116					
850 XS (4cyl)	3493913	4831998	18-3017			18-3116					
850, 850 XS (4cyl)	3493913	4590511	18-3017			18-3116					
900 (90hp) (6 cyl) 11	1766824	1869775	18-3017	18-3117				18-3217		18-3517	
90 (6 cyl)	4845301	& UP	18-3017	18-3117	18-3114	18-3116	18-3414	18-3217			
90 (3 cyl)	B110054	C221999	18-3056					18-3214			
90 (3 cyl)	A996142	& UP	18-3056					18-3214	18-3553		
90 (3 cyl)	A996142	& UP	18-3056	18-3122				18-3214	18-3553		
90 4-STROKE	G960500	B366822	18-3056			18-3572		18-3214			
90 4-STROKE	B366823	& UP	18-3056			18-3572		18-3214			
95	1869776	2318585	18-3017	18-3117				18-3217			
115 (3CYL) Optimax	T801000	& UP	18-3056			18-3572					
950 (95hp) (6 cyl) 11	1869776	2318585	18-3017								
1000(6 cyl)	1464949	1503331	18-3017	18-3117				18-3217			
1000 (6cyl)	1503332	2318585	18-3017			18-3116					
100 (4 cyl)	B209468	& UP	18-3056					18-3214	18-3553		
100 (4 cyl)	B209468	& UP	18-3056	18-3122				18-3214	18-3553		18-3517
1000 SS (6cyl) 1	2318586	2413843	18-3017			18-3116					
1000 SS (6cyl) 3	2318586	2413843	18-3017			18-3116					
1000 SS E-1 1	2484633	2836018	18-3017			18-3116					
1000 SS E-1 3	2484633	2836018	18-3017			18-3116					
1000 BP (6cyl)	2399698	3253111	18-3017			N.L.A.					
105 Jet	0D182000	& UP	18-3017	18-3117	18-3114	18-3116	18-3419	18-3217			
110 1	1870204	2314955	18-3017	18-3117				18-3217			
110 3	1870204	2314955	18-3017			18-3317					
115 (6cyl)	2836019	4112634	18-3017	18-3117				18-3217		18-3517	
115 (6cyl)	4112635	4394236	18-3017								
115 (6 cyl)	4394237	& UP	18-3017	18-3117	18-3114	18-3116	18-3414	18-3217			
115 (4 cyl) 6	C100000	& UP	18-3056					18-3214	18-3569		
115 (4cyl) 5	C100000	& UP	18-3056			18-3572			18-3569		
115 (4 cyl)	B209468	& UP	18-3056	18-3122				18-3214			
115 4-STROKE	T178500	B366822	18-3056					18-3214			
115 4-STROKE	B366823	& UP	18-3056			18-3572					
115 (3cyl) Optimax	T801000	& UP	18-3056			18-3572					
115 Pro XS	B751825	& UP	18-3056			18-3572					
125 (6cyl) 2	2314956	2839368	18-3017	18-3117				18-3217			
125 (6cyl) 4	2314956	2839368	18-3017								
125 (4 cyl) 6	D283222	& UP	18-3056						18-3569		
125 (4cyl) 5	D283222	& UP	18-3056			18-3572					
125 (3cyl) Optimax	B736885	& UP	18-3056			18-3572					

1 Models with aluminum upper pump housings
 2 Models with aluminum water pumps
 3 Models with plastic upper pump housings
 4 Models with plastic water pumps
 5 Pump screws without insulators
 6 Pump screws with insulators
 7 Models with driveshaft retaining nut
 8 Models without driveshaft retaining nut
 9 Models with flush hole
 10 Models without flush hole
 11 Models having plastic upper housing use #48752 inset cup
 12 Units already having a complete pump replacement using 46-46893A 6 should use the 2193818-2529894 serial group for components
 13 Units already having a complete pump replacement using 46-46893A 6 should use USA 3795658-4126549 serial group for components
 14 Units which have already had a complete pump replacement with the 46-46893A 6 pump should use the "Early Mariner Impellers" chart for components

MERCURY COOLING SYSTEM APPLICATION

Horsepower	Beginning Serial #	Ending Serial #	Impeller	Impeller Plate	Insert Cup	Upper Housing	Base	Impeller Repair Kit	Thermostat	Upper Kit	Complete Kit
135	2839369	3293233	18-3017	18-3117				18-3217			18-3517
V 135	904646	& UP	18-3017	18-3117	18-3114	18-3116	18-3419	18-3217			—
135 4-STROKE VERADO	B227000	& UP	18-3056			18-3572					18-3407
140	3293234	3502805	18-3017	18-3117				18-3217			18-3517
140	4865678	& UP	18-3017	18-3117	18-3114	18-3116	18-3414	18-3217			18-3517
140 Jet	D082000	& UP	18-3017	18-3117	18-3114	18-3116	18-3419	18-3217			—
150	3502806	4121434	18-3017	18-3117				18-3217			18-3517
150 (6cyl)	9 4121435	4865677	18-3017	18-3117	18-3114	18-3116	18-3414	18-3217			18-3517
150 (6cyl)	10 4121435	4865677	18-3017				18-3414				
1500 XS (6cyl)	4868648	5327662	18-3017								
V 150	A904646	& UP	18-3017	18-3117	18-3114	18-3116	18-3419	18-3217			18-3517
V 150	A904645	& BELOW	18-3017	18-3117	18-3114	18-3116	18-3416	18-3217			18-3517
V-135 DFI	G590000	& UP	18-3017								
V-150 Carb	8 4868998	A904645	18-3017								
V-150 Carb	7 4868998	A904645	18-3017								
V-150 Carb, EFI, DFI	A904646	& UP	18-3017								
V-150XR2,4,6 - MAGNUM II, III	8 4868998	& UP	18-3017								
V150XR2,4,6 - MAGNUM II, III	7 4868998	& UP	18-3017								
150 4-STROKE VERADO (4cyl)	B227000	& UP	18-3056			18-3572				18-3406	18-3407
V 175	6618751	& UP	18-3017	18-3117	18-3114	18-3116	18-3419	18-3217			18-3517
V 175	4301235	6618750	18-3017	18-3117	18-3114	18-3116	18-3416	18-3217			18-3517
V-175 Carb, EFI, DFI	6618751	& UP	18-3017								
175 4-STROKE VERADO (4cyl)	B227000	& UP	18-3056			18-3572				18-3406	18-3407
V 200	6625221	& UP	18-3017	18-3117	18-3114	18-3116	18-3419	18-3217			18-3517
V-200	8 4839034	6625220	18-3017	18-3117	18-3114	18-3116	18-3416	18-3217			—
V-200	7 4839034	6625220	18-3017								
V-200 DFI (3.0L)	G386496	G589999	18-3056					18-3214			18-3517
V-200 EFI (3.0L)	T750164	B504988	18-3056								
V-200 Carb, & EFI (2.5L)	6625221	& UP	18-3017								
V-200 DFI (3.0L)	G590000	T598999	18-3056			18-3572					
V-200 DFI (3.0L)	T590000	B504988	18-3056			18-3572					
V-200 DFI (3.0L)	B504989	& UP	18-3056			18-3572					18-3407
200 4-STROKE VERADO (4cyl)	B517159	& UP	18-3056			18-3572				18-3406	18-3407
200 4-STROKE 4.8 INCH TORPEDO	T980000	& UP	18-3056			18-3572				18-3406	18-3407
V 220 LASER	B117316	& UP	18-3017	18-3117	18-3114	18-3116	18-3419	18-3217			18-3517
V-225 (2.4L)	8 5628028	& UP	18-3017								
V-225 (2.4L)	7 5628028	& UP	18-3017								
V-225 (3.0L) CARB & EFI	D280813	G760299	18-3056								
V-225 (3.0L) CARB & EFI	G760300	T408999	18-3056			18-3571					
V-225 (3.0L) EFI	T409000	B504988	18-3056			18-3571					
V-225 DFI	G590000	T598999	18-3056			18-3571					
V-225 DFI	T599000	B504988	18-3056			18-3571					
V-225 DFI	B504989	& UP	18-3056			18-3571					18-3407
V-225 Pro XS	B104549	B752546	18-3056			18-3571					
V-225 Pro XS	B752547	& UP	18-3056			18-3571					18-3407
225 4-STROKE VERADO 4.8 INCH TORPEDO	T980000	& UP	18-3056			18-3572					18-3407
V-250 (3.0L) EFI	G129222	T408999	18-3056			18-3571					
V-250 (3.0L) EFI	T409000	B504988	18-3056			18-3572					
V-250 DFI	B528615	& UP	18-3056			18-3572					18-3407
V-250 Pro XS	B426561	B752546	18-3056			18-3571					
V-250 Pro XS	B752547	& UP	18-3056			18-3572					18-3407
250 4-STROKE VERADO 4.8 INCH TORPEDO	T980000	& UP	18-3056			18-3572					18-3407
275 4-STROKE VERADO 4.8 INCH TORPEDO	T980000	& UP	18-3056			18-3572					18-3407
300 4-STROKE VERADO 4.8 INCH TORPEDO	B517434	& UP	18-3056			18-3572					18-3407
MARK 5	574128	786612	18-3012								
MARK 6, 6A	888005	& UP	18-3012								
MARK 50	ALL	& UP	18-3007								
MARK 55	831021	& UP	18-3007								
MARK 55A	1227131	& UP	18-3007								
MARK 58 E, MARK 58A (M&E)	1139538	& UP	18-3007								
9	OG129222	& UP	18-3056	18-3117	18-3114	18-3116	18-3419	18-3214			18-3517
XR4/Magnum II	ALL		18-3017					18-3217			

- 1 Models with aluminum upper pump housings
- 2 Models with aluminum water pumps
- 3 Models with plastic upper pump housings
- 4 Models with plastic water pumps
- 5 Pump screws without insulators
- 6 Pump screws with insulators
- 7 Models with driveshaft retaining nut

- 8 Models without driveshaft retaining nut
- 9 Models with flush hole
- 10 Models without flush hole
- 11 Models having plastic upper housing use #48752 inset cup
- 12 Units already having a complete pump replacement using 46-46893A 6 should use the 2193818-2529894 serial group for components
- 13 Units already having a complete pump replacement using 46-46893A 6 should use USA 3795658-4126549 serial group for components
- 14 Units which have already had a complete pump replacement with the 46-46893A 6 pump should use the "Early Mariner Impellers" chart for components

ALL PISTONS ARE SUPPLIED COMPLETE WITH PISTON RINGS, WRIST PIN AND CIRCLIPS.

MARINER (JAPANESE MODELS)

Sierra Piston Kit Contents (See Application Charts for Specific Applications)

Model / HP	Cyl.	Bore Size	Piston	OEM Part #	Piston Ring	OEM Part #
9.9 / 15	2	std	18-4135	761-7982M, 761-7982T, 761-7134M, 761-7133M, 761-7131M	18-3976	39-15320M, 39-15320T
48	2	std	18-4138	761-8484M, 761-7198M, 761-7197M, 761-7196M	—	—

MARINER PISTON RINGS - JAPANESE MODELS

.25mm O.S.	O.E. #	.25mm O.S.	O.E. #	.25mm O.S.	O.E. #	.50mm O.S.	O.E. #
18-3977	39-18939M, 39-18939T	18-3986	39-81096M	18-3992	39-83196M	18-3978	39-15322M

MARINER PISTON AND RINGS APPLICATION - JAPANESE MODELS

Model	Ser# Code	Ser #	Standard Piston	.25mm Piston	.50mm Piston	Standard Rings	.25mm Rings	.50mm Rings	Qty. Req'd
9.9	682	ALL	18-4135	—	—	18-3976	18-3977	18-3978	2
15C	684	ALL	18-4135	—	—	18-3976	18-3977	18-3978	2
30A	689	ALL	18-4138	—	—	—	—	—	2
20C, 25A	6A9	ALL	—	—	—	—	18-3986	—	2
25C	695	ALL	—	—	—	—	18-3986	—	2
28	664	ALL	—	—	—	—	18-3986	—	2
48	670	S-02441 & Up / L33132 & UP	—	—	—	—	18-3992	—	2
W48	670	M 002731 & Up / ML 314101 & Up	—	—	—	—	18-3992	—	2
60	675	E 00101-001170 / EL 30101-304180	—	—	—	—	18-3992	—	2

MERCURY / MARINER

Sierra Piston Kit Contents (See Application Charts for Specific Applications)

Model / HP	Cyl.	Bore Size	Piston	OEM Part #	Piston Ring	OEM Part #	Circlips	OEM Part #
2 RING PISTONS - HIGH DOME								
35-140	2 - 6	2.875 / Std.	—	774-9137A12	18-3918	39-817096A6	18-4294 ④	40-52035
35-140	2 - 6	2.890 / .015	—	774-9137A13	18-3919	39-817096A16	18-4294 ④	40-52035
35-140	2 - 6	2.905 / .030	18-4535	774-9137A14	18-3920	39-817096A26	18-4294 ④	40-52035
2 RING PISTONS - LOW DOME								
35-140	2 - 6	2.875 / Std.	—	774-9137A9	18-3918	39-817096A6	18-4294 ④	40-52035
35-140	2 - 6	2.890 / .015	18-4515	774-9137A10	18-3919	39-817096A16	18-4294 ④	40-52035
35-140	2 - 6	2.905 / .030	—	774-9137A11	18-3920	39-817096A26	18-4294 ④	40-52035
3 RING PISTONS - HIGH DOME								
35-140	2 - 6	2.875 / Std.	—	776-8896A3	① 18-3902	39-78816A12, 39-45155A12	18-4294 ④	40-52035
35-140	2 - 6	2.890 / .015	—	776-8897A2	18-3916	39-78811A12, 39-45204A12	18-4294 ④	40-52035
35-140	2 - 6	2.905 / .030	18-4535	776-8898A2	① 18-3917	39-88392A12, 39-88392	18-4294 ④	40-52035
3 RING PISTONS - LOW DOME								
35-140	2 - 6	2.875 / Std.	—	776-8600A9	② 18-3902	39-78816A12	18-4294 ④	40-52035
35-140	2 - 6	2.890 / .015	—	776-9095A1	② 18-3916	39-78811A12, 39-45204A12	18-4294 ④	40-52035
35-140	2 - 6	2.905 / .030	18-4156	776-9096A1	18-3917	39-88392A12, 39-88392	18-4294 ④	40-52035
2 RING PISTONS - CROSSFLOW								
40-50	4	2.565 / Std.	18-4620	780-9229A7, 743-5172A6, 743-3193A4, 743-3193A2	18-3966	39-18653A12	18-4294 ④	40-52035
40-50	4	2.580 / .015	18-4621	780-9229A10, 743-3366A2, 743-3366A1	18-3967	39-18653A1	18-4294 ④	40-52035
40-50	4	2.595 / .030	18-4622	780-9229A11, 743-7716A2	18-3968	39-18653A2	18-4294 ④	40-52035
50-60	3	2.875 / Std.	—	783-9613A1	18-4019	39-19721A6	18-4294 ④	40-52035
50-60	3	2.890 / .015	18-4017	783-9613A2, 783-9613T2	18-4020	39-19721A1	18-4294 ④	40-52035
50-60	3	2.905 / .030	18-4018	783-9613A3, 783-9613T3	18-4021	39-19721A2	18-4294 ④	40-52035
70-115	3-4	3.375 / Std.	18-4623	777-815965T4, 777-815965A4	18-3979	39-96170A12	18-4294 ④	40-52035
70-115	3-4	3.390 / .015	18-4624	777-815965A5	—	39-96170A3	18-4294 ④	40-52035
70-115	3-4	3.405 / .030	18-4625	777-815965A6	18-3981	39-96170A4	18-4294 ④	40-52035
75-125	3-4	3.500 / Std.	18-4626	2704-826191T4, 2704-826191A4, 2704-826191A6, 2704-821896A6, 2704-812896A2	18-3982	39-822321A12, 39-824905A12	18-4294 ④	40-52035
75-125	3-4	3.515 / .015	18-4627	2704-821896A3	—	39-822321A1	18-4294 ④	40-52035
75-125	3-4	3.530 / .030	18-4628	2704-821896A4	18-3984	39-822321A2	18-4294 ④	40-52035

3 RING PISTON AND RINGS APPLICATION (REFERENCE ONLY ③)

HP	Cyl.	Beginning Serial No.	Ending Serial No.	Std. Cyl. Dia. (Bore)	Std. Piston	.015 O.S. Piston	.030 O.S. Piston	Std. Rings	.015 O.S. Rings	.030 O.S. Rings
3.5	1	6202173	& UP	2	—	—	—	—	—	—

APPLICATION CONTINUED ON NEXT PAGE

- ① 3 ring high dome NLA, 2 ring piston are now substituted ② 3 ring low dome NLA, 2 ring piston are now substituted
 ③ Chart is for referencing only, pistons received will be 2 ring version
 ④ This product is priced per piece. To order priced per package, please add -9 to the part number.

3 RING PISTON AND RINGS APPLICATION (REFERENCE ONLY ☺)

HP	Cyl.	Beginning Serial No.	Ending Serial No.	Std. Cyl. Dia. (Bore)	Std. Piston	.015 O.S. Piston	.030 O.S. Piston	Std. Rings	.015 O.S. Rings	.030 O.S. Rings
3.6	1	5404657	& UP	2	—	—	—		—	—
3.9	1	1655013	2498135	2	—	—	—		—	—
4 (1CYL)	1	2498136	A809600	2	—	—	—		—	—
4.5	1	4107220	& UP	2	—	—	—		—	—
7.5	2	2529895	& UP	2	—	—	—		—	—
9.8	2	1470349	& UP	2	—	—	—		—	—
20	2	1922910	5942040	2.562	—	—	—	—	—	—
25	2	1467499	149931	2.562	—	—	—	—	—	—
30 Jet (40 HP)	4	0C159200	& UP	2.562	18-4620	18-4621	18-4622	18-3966	18-3967	18-3968
30 Jet (40 HP)		0C159200	& UP	2.562	18-4620	18-4621	18-4622	18-3966	18-3967	18-3968
35	2	6445653	& UP	2.875	—	—	18-4535	18-3918	18-3916	18-3920
40 (4 cyl)	4	1279085	1476509	2.562	—	—	—	—	—	—
40	2	2045260	C159199	2.875	—	—	18-4535	18-3918	18-3916	18-3920
40, 402	2	3336258	6445652	2.875	—	—	18-4535	18-3918	18-3916	18-3920
40	4	0C159200	& UP	2.562	18-4620	18-4621	18-4622	18-3966	18-3967	18-3968
45	4	1476510	& UP	2.562	18-4620	18-4621	18-4622	18-3966	18-3967	18-3968
45	4	5531630	0B110788	2.562	18-4620	18-4621	18-4622	18-3966	18-3967	18-3968
45	4	0B110789	& UP	2.562	18-4620	18-4621	18-4622	18-3966	18-3967	18-3968
45 JET	3	D000750	G589999	2.955	—	18-4017	18-4018	18-4019	18-4020	18-4021
50,500	4	2116318	6428680	2.562	18-4620	18-4621	18-4622	18-3966	18-3967	18-3968
50	3	6428681	B122929	2.875	18-4500	18-4515	—	18-3918	18-3916	18-3920
50	3	B122930	D000749	2.875	18-4500	—	—	18-3918	18-3916	18-3920
50	3	D000750	G589999	2.955	—	18-4017	18-4018	18-4019	18-4020	18-4021
55	3	6428681	B122929	2.875	18-4500	18-4515	—	18-3918	18-3916	18-3920
55	3	B122930	D000749	2.875	18-4500	18-4515	—	18-3918	18-3916	18-3920
55	3	D000750	G589999	2.955	—	18-4017	18-4018	18-4019	—	18-4021
60	6	1303411	1542744	2.562	—	—	—	—	18-4020	—
60	3	6428681	B122929	2.875	—	—	18-4535	18-3918	18-3916	18-3920
60	3	B122930	D000749	2.875	—	—	18-4535	18-3918	18-3916	18-3920
60	3	D000750	G589999	2.955	—	18-4017	18-4018	18-4019	18-4020	18-4021
65,650	3	3293184	4382056	2.875	—	—	18-4535	18-3918	18-3916	18-3920
65,650	3	4382057	4571651	2.875	—	—	18-4535	18-3918	18-3916	18-3920
70	3	4571652	A996141	2.875	—	—	18-4535	18-3918	18-3916	18-3920
70 (3 cyl.) w/Rod #646-8188461	3	A996142	& UP	3.375	18-4623	18-4624	18-4625	18-3979	—	—
75	4	6432901	& UP	2.875	—	—	18-4535	18-3918	18-3916	18-3920
75 (3 cyl.) w/Rod #646-818846	3	C222000	D283221	3.375	18-4623	18-4624	18-4625	18-3979	—	18-3981
75 (3 cyl.)	3	D283222	& UP	3.5	18-4626	18-4627	18-4628	18-3982	—	—
80,800	4	2559001	3493912	2.875	—	—	18-4535	18-3918	18-3916	18-3920
80,800	4	4831999	6432900	2.875	—	—	18-4535	18-3918	18-3916	18-3920
80 Jet	3	D283222	& UP	3.5	18-4626	18-4627	18-4628	18-3982	—	—
85,850	4	3493913	4831998	2.875	—	—	18-4535	18-3918	18-3916	18-3920
85,850	4	4366802	4831998	2.875	—	—	18-4535	18-3918	18-3916	18-3920
85 Mar.	4	4731898	4842728	2.875	—	—	18-4535	18-3918	18-3916	18-3920
90,900	6	4845301	& UP	2.875	—	—	18-4535	18-3918	18-3916	18-3920
90 (3 cyl.) w/Rod #646-818846	3	A9964142	D283221	3.375	18-4623	18-4624	18-4625	18-3979	—	18-3981
90 (3 cyl.)	3	D283222	& UP	3.5	18-4626	18-4627	18-4628	18-3982	—	—
95	6	1869776	2318585	2.875	—	—	—	18-3918	18-3916	18-3920
100 SS	6	2318586	2836018	2.875	—	—	—	18-3918	18-3916	18-3920
100 BP	6	2399698	3253111	2.875	—	—	—	18-3918	18-3916	18-3920
100 (4 cyl.) w/Rod #646-818846	4	B209468	D283221	3.375	18-4623	18-4624	18-4625	18-3979	—	18-3981
100 (4cyl)	4	D283222	& UP	3.5	18-4626	18-4627	18-4628	18-3982	—	—
115 1150	6	2836019	5829643	2.875	—	—	18-4535	18-3918	18-3916	18-3920
115 Merc.	6	5829644	B209467	2.875	18-4500	18-4515	—	18-3918	18-3916	18-3920
115 Mar.	6	5738891	5861526	2.875	—	—	18-4535	18-3918	18-3916	18-3920
115 Mar.	6	5861527	C100000	2.875	18-4500	18-4515	—	18-3918	18-3916	18-3920

APPLICATION CONTINUED ON NEXT PAGE

3 RING PISTON AND RINGS APPLICATION (REFERENCE ONLY ③)										
HP	Cyl.	Beginning Serial No.	Ending Serial No.	Std. Cyl. Dia. (Bore)	Std. Piston	.015 O.S. Piston	.030 O.S. Piston	Std. Rings	.015 O.S. Rings	.030 O.S. Rings
115 (4 cyl) w/Rod #646-818846	4	C100000	D283221	3.375	18-4623	18-4624	18-4625	18-3979	—	18-3981
115 (4cyl)	4	D283222	& UP	3.5	18-4626	18-4627	18-4628	18-3982	—	—
125 BP	6	2641855	3253111	2.875	—	—	18-4535	18-3918	18-3916	18-3920
135	6	2839369	3293233	2.875	—	—	18-4535	18-3918	18-3916	18-3920
140 1400	6	3293234	3502805	2.875	—	—	18-4535	18-3918	18-3916	18-3920
140 1400	6	4865678	& UP	2.875	18-4500	18-4515	—	18-3918	18-3916	18-3920
150 1500	6	3502806	5327622	2.875	18-4500	18-4515	—	18-3918	18-3916	18-3920

③ Chart is for referencing only, pistons received will be 2 ring version

2 RING INLINE PISTON & RINGS APPLICATION														
HP	Cyl.	Beginning Serial No.	Ending Serial No.	Dia. (Bore)	Pistons			Port		Port		Piston Rings		
					Std. (Port)	Stbd.	.015" O.S.	Stbd.	.030 O.S.	Stbd.	Std.	.015" O.S.	.030 O.S.	
105 JET	V-6	D082000	& UP	3.125	—	—	—	18-4013	18-4014	—	—	18-3921	18-3922	18-3923
V-135	V-6	A904646	C239552	3.125	—	—	—	18-4560	—	—	18-4575	18-3921	18-3922	18-3923
V-135 (w/ rod 644-8141)	V-6	C239553	G960499	3.125	—	—	—	18-4013	18-4014	—	—	18-3921	18-3922	18-3923
V-135 (2.5L) (w/o rod 636-8141)	V-6	C239553	G960499	3.125	—	—	—	18-4560	—	—	18-4575	18-3921	18-3922	18-3923
V-140 JET	V-6	D082000	G960499	3.5	18-4635	18-4636	18-4637	18-4638	NA	NA	18-3982	—	18-3984	
V-140 JET	V-6	G960500	UP	3.5	18-4635	18-4636	18-4637	18-4638	NA	NA	18-3982	—	18-3984	
V-150 MAR	V-6	5600162	6038680	3.125	—	—	—	18-4560	—	—	18-4575	18-3921	18-3922	18-3923
V-150 MAR	V-6	6038681	C239552	3.125	—	—	—	18-4560	—	—	18-4575	18-3921	18-3922	18-3923
V-150, 150,1500	V-6	4868998	6042945	3.125	—	—	—	18-4560	—	—	18-4575	18-3921	18-3922	18-3923
V-150	V-6	6042946	C239552	3.125	—	—	—	18-4560	—	—	18-4575	18-3921	18-3922	18-3923
V-150 (w/ rod 644-8141)	V-6	C239553	G960499	3.125	—	—	—	18-4013	18-4014	—	—	18-3921	18-3922	18-3923
V-150 (2.5L) (w/o rod 636-8141)	V-6	C239553	G960499	3.125	—	—	—	18-4560	—	—	18-4575	18-3921	18-3922	18-3923
V-150 EFI XR6 MAGIII	V-6	D082000	G960499	3.5	18-4635	18-4636	18-4637	18-4638	NA	NA	18-3982	—	18-3984	
V-150 XR4 MAGIII	V-6	B242885	C239552	3.375	—	—	—	18-4565	18-4570	—	—	18-3924	18-3925	—
V-150 XR4 MAGIII	V-6	C239553	D081999	3.375	—	—	—	18-4565	—	—	—	18-3924	18-3925	—
V-175,175, 1750	V-6	4301235	6618750	3.125	—	—	—	18-4560	—	—	18-4575	18-3921	18-3922	18-3923
V-175	V-6	6618751	C239552	3.375	—	—	—	—	—	—	—	18-3927 ④	—	—
V-175	V-6	C239553	D081999	3.375	—	—	—	18-4565	—	—	—	18-3924	18-3925	—
V-175	V-6	D082000	G960499	3.5	18-4635	18-4636	18-4637	18-4638	NA	NA	18-3982	—	18-3984	
V-175	V-6	G960500	& UP	3.5	18-4635	18-4636	18-4637	18-4638	NA	NA	18-3982	—	18-3984	
V-175 I XRI EF	V-6	D000750	D081999	3.5	18-4635	18-4636	18-4637	18-4638	NA	NA	18-3982	—	18-3984	
V-175	V-6	D000750	D081999	3.5	18-4635	18-4636	18-4637	18-4638	NA	NA	18-3982	—	18-3984	
V-175 XRI EFI	V-6	D082000	G303045	3.5	18-4635	18-4636	18-4637	18-4638	NA	NA	18-3982	—	18-3984	
V-175 XRI EFI	V-6	G303046	& UP	3.5	18-4635	18-4636	18-4637	18-4638	NA	NA	18-3982	—	18-3984	
V-200, 2,002,000	V-6	4839034	6203990	3.375	—	—	—	—	—	—	—	18-3927 ④	—	—
V-200 (2.4L)	V-6	6203991	C291519	3.375	—	—	—	—	—	—	—	18-3927 ④	—	—
V-200 (2.5L) (w/ rod #644-818141)	V-6	C291520	D081999	3.5	18-4635	18-4636	18-4637	18-4638	NA	NA	18-3982	—	18-3984	
V-200 (2.5L)	V-6	D082000	& UP	3.5	18-4635	18-4636	18-4637	18-4638	NA	NA	18-3982	—	18-3984	
V-200 XRI EFI	V-6	C100861	C291519	3.375	—	—	—	—	—	—	—	18-3927 ④	—	—
V-200 XRI EFI	V-6	C291520	G960499	3.5	18-4635	18-4636	18-4637	18-4638	NA	NA	18-3982	—	18-3984	
V-220	V-6	B117316	UP	3.375	—	—	—	—	—	—	—	18-3927 ④	—	—
V-225	V-6	5628028	D280812	3.375	—	—	—	—	—	—	—	18-3927 ④	—	—
V-225 (3.0L)	V-6	D280813	UP	3.625	18-4639	18-4640	18-4641	18-4642	—	—	18-4644	18-4050	18-4051	18-4052

SIERRA V-6 PISTON KIT CONTENTS (SEE APPLICATION CHARTS FOR SPECIFIC APPLICATIONS)

Model / HP	Cyl.	Bore Size	Piston	OEM Part #	Piston Ring	OEM Part #	Wrist Pin	Circlips
135, 150 2 Liter	V-6	3.125 / Std. (port)	—	765-7442T32	18-3921	39-93481A12	18-4287	N.S.S.
135, 150 2 Liter	V-6	3.125 / Std. (stbd)	—	765-7441T32	18-3921	39-93481A12	18-4287	N.S.S.
135, 150 2 Liter	V-6	3.140 / .015 (port)	—	765-7444A11	18-3922	39-78918A4	18-4287	N.S.S.
135, 150 2 Liter	V-6	3.140 / .015 (stbd)	18-4013	765-7443A11	18-3922	39-78918A4	18-4287	N.S.S.
135, 150 2 Liter	V-6	3.155 / .030 (port)	18-4014	765-7446A11	18-3923	39-85636A4	18-4287	N.S.S.

- | | | | |
|---------------------------------|----------------------------------|---------------------------------|----------------------------------|
| 4 of — = 1 of 39-21665A12 | 3 of 18-3919 = 1 of 39-817096A16 | 6 of 18-3924 = 1 of 39-18487A12 | 3 of 18-4019 = 1 of 39-19721A6 |
| 4 of 18-3902 = 1 of 39-78816A12 | 3 of 18-3920 = 1 of 39-817096A26 | 2 of 18-3925 = 1 of 39-815267A4 | 6 of 18-3982 = 1 of 39-822321A12 |
| 4 of 18-3916 = 1 of 39-78811A12 | 6 of 18-3921 = 1 of 39-93481A12 | 6 of 18-3966 = 1 of 39-18653A12 | 6 of 18-4050 = 1 of 39-827179A12 |
| 4 of 18-3917 = 1 of 39-88392A12 | 2 of 18-3922 = 1 of 39-78918A4 | 6 of 18-3968 = 1 of 39-18653A2 | 6 of 18-3927 = 1 of 39-813011A12 |
| 3 of 18-3918 = 1 of 39-817096A6 | 2 of 18-3923 = 1 of 39-85636A4 | 6 of 18-3967 = 1 of 39-18653A1 | |

APPLICATION CONTINUED ON NEXT PAGE

SIERRA V-6 PISTON KIT CONTENTS (SEE APPLICATION CHARTS FOR SPECIFIC APPLICATIONS)

Model / HP	Cyl.	Bore Size	Piston	OEM Part #	Piston Ring	OEM Part #	Wrist Pin	Circlips
135, 150 2 Liter	V-6	3.155 / .030 (stbd)	—	765-7445T11	18-3923	39-85636A4	18-4287	N.S.S.
135-175	V-6	3.125 / Std. (port)	—	765-7442A3, A36	18-3921	39-93481A12	18-4287	N.S.S.
135-175	V-6	3.125 / Std. (stbd)	18-4545	765-7441A3, A36	18-3921	39-93481A12	18-4287	N.S.S.
135-175	V-6	3.140 / .015 (port)	—	765-7442A2, A12	18-3922	39-78918A4	18-4287	N.S.S.
135-175	V-6	3.140 / .015 (stbd)	18-4560	765-7443A2, A12	18-3922	39-78918A4	18-4287	N.S.S.
135-175	V-6	3.155 / .030 (port)	—	N/A	18-3923 ④	39-85636A4	18-4287	N.S.S.
135-175	V-6	3.155 / .030 (stbd)	18-4575	N/A	18-3923 ④	39-85636A4	18-4287	N.S.S.
175-225	V-6	3.375 / Std. (port)	—	766-8667A41/ T41	18-3927 ④	39-813011A12	18-4287	N.S.S.
175-225	V-6	3.375 / Std. (stbd)	—	766-8666A41/ T41	18-3927 ④	39-813011A12	18-4287	N.S.S.
175-225	V-6	3.390 / .015 (port)	—	766-8667A36/ A43	18-3925	39-815267A4	18-4287	N.S.S.
175-225	V-6	3.390 / .015 (stbd)	—	766-8666A36/ A43	18-3925	39-815267A4	18-4287	N.S.S.
175-225	V-6	3.405 / .030 (port)	—	NLA	—	NLA	18-4287	N.S.S.
150 XR4/MAG II	V-6	3.375 / Std. (port)	—	766-8667A42/ T42	18-3924	39-18487A12	18-4287	N.S.S.
150 XR4/MAG II	V-6	3.375 / Std. (stbd)	—	766-8666A42/ T42	18-3924	39-18487A12	18-4287	N.S.S.
150 XR4/MAG II	V-6	3.390 / .015 (port)	18-4565	766-8667A36/ A43	18-3925	39-815267A4	18-4287	N.S.S.
150 XR4/MAG II	V-6	3.390 / .015 (stbd)	—	766-8666A36/ A43	18-3925	39-815267A4	18-4287	N.S.S.
150 XR4/MAG II	V-6	3.405 / .030 (port)	18-4580	NLA	—	NLA	18-4287	N.S.S.
140-200, XR6/MAG III	V-6	3.500 / Std. (port)	18-4635	785-9737T9	18-3982	39-822321A12	18-4287	N.S.S.
140-200, XR6/MAG III	V-6	3.500 / Std. (stbd)	18-4636	785-9738T9	18-3982	39-822321A12	18-4287	N.S.S.
140-200, XR6/MAG III	V-6	3.515 / .015 (port)	18-4637	785-9737A10	—	39-822321A1	18-4287	N.S.S.
140-200, XR6/MAG III	V-6	3.515 / .015 (stbd)	18-4638	785-9738T10	—	39-822321A1	18-4287	N.S.S.
225 (3.0L)	V-6	3.6265 / Std. (port)	18-4639	700-858294T1	18-4050	39-827179A12	18-4287	N.S.S.
225 (3.0L)	V-6	3.6265 / Std. (stbd)	18-4640	700-858295T1	18-4050	39-827179A12	18-4287	N.S.S.
225 (3.0L)	V-6	3.6415 / .015 (port)	18-4641	700-878571A2	18-4051	39-826293A12	18-4287	N.S.S.
225 (3.0L)	V-6	3.6415 / .015 (stbd)	18-4642	700-878572A2	18-4051	39-826293A12	18-4287	N.S.S.
225 (3.0L)	V-6	3.6565 / .030 (port)	18-4643	700-878573A2	18-4052	39-826297A12	18-4287	N.S.S.
225 (3.0L)	V-6	3.6565 / .030 (stbd)	18-4644	700-878574A2	18-4052	39-826297A12	18-4287	N.S.S.

4 of — = 1 of 39-21665A12
 4 of 18-3902 = 1 of 39-78816A12
 4 of 18-3916 = 1 of 39-78811A12
 4 of 18-3917 = 1 of 39-88392A12
 3 of 18-3918 = 1 of 39-817096A6

3 of 18-3919 = 1 of 39-817096A16
 3 of 18-3920 = 1 of 39-817096A26
 6 of 18-3921 = 1 of 39-93481A12
 2 of 18-3922 = 1 of 39-78918A4
 2 of 18-3923 = 1 of 39-85636A4

6 of 18-3924 = 1 of 39-18487A12
 2 of 18-3925 = 1 of 39-815267A4
 6 of 18-3966 = 1 of 39-18653A12
 6 of 18-3968 = 1 of 39-18653A2
 6 of 18-3967 = 1 of 39-18653A1

3 of 18-4019 = 1 of 39-19721A6
 6 of 18-3982 = 1 of 39-822321A12
 6 of 18-4050 = 1 of 39-827179A12
 6 of 18-3927 = 1 of 39-813011A12

④ For chrome bore blocks

PKG. OF 200



NEEDLE BEARINGS

Part #	Replaces:	Description
18-4036 ①	29-47270	Piston End
18-4037 ①	29-71422	Main Bearing

NEEDLE BEARINGS



Part #	Replaces	Description
18-4038	31-62596A1, 31-63075A1, 31-61424A2, 31-58859A1, 31-55332A1, 31-47245A1	Crank End - w/o Cage
18-4039	31-17514A2, 31-8M0045430	Crank End - w/o Cage

16 Needles - Must re-use cage



18-1186
NEEDLE BEARINGS WITH RETAINERS

Replaces: 29-88258 + 12-88263

(2 pieces)
For: Merc V-6 200/225/250 HP 3.0 & 3.4L

18-1194
ROD BEARING

Replaces: 31-17514A1, 8M004528, 31-17514A2, 31-8M0045428, 31-17514, 31-67526A1, 31-67526A2, 31-67526, 31-821146A1, 31-814337A1, 879366
For: 30-60HP 2&3 Cyl., Mag II, V-135-200 & XR4



18-1195
ROD BEARING

Replaces: 31-43012A1
For: 70, 75, 80, 90, 100, 115, L3, L4, 3.0L



18-1153
BALL BEARING

Replaces: 30-63326, 30-63326T, 30-49313, 30-54215, 30-20464



18-1154
BALL BEARING

Replaces: 30-63742



18-1196
UPPER MAIN BEARING

Replaces: 31-74248T, 31-74248
For: V135, 150, 175, 200 (carb)



18-1345
BALL BEARING

Replaces: 30-67923T, 30-67923, 30-41421
For: 135-225 HP V-6



① This product is priced per piece. To order priced per package, please add -9 to the part number.

**18-1346
BALL BEARING**

Replaces: 30-43011T, 30-43011
For: 75-125 3 & 4 cyl.



**18-1398
BALL BEARING**

Replaces: 30-72961, 30-20861
For: 3.5-9.8 HP & Mercruiser belt driven water pump



HP	Cyl.	Beg. S/N	End S/N	Center Main Bearing	Con. Rod Crank End	Main Valve Block	Con. Rod Piston End	Lower Main Bearing	Lower O-ring	Lower Oil Seal	Lower Oil Seal 2	Upper O-ring	Upper Main Bearing	Upper Oil Seal	Upper Roller Bearing
3.5		6202173	& UP	—	—	—	—	—	—	—	—	18-7152	18-1398	—	—
3.6		5404657	& UP	—	—	—	—	18-1398	—	—	—	18-7152	18-1398	—	—
3.9	1	1655013	2498135	—	—	—	—	18-1398	—	—	—	18-7152	18-1398	—	—
4 (40)	1	2498136	4107219	—	—	—	—	18-1398	—	—	—	18-7152	18-1398	—	—
4	1	5595532	& UP	—	—	—	—	18-1398	—	—	—	18-7152	18-1398	—	—
4 (40)	2	5589202	& UP	—	—	—	—	18-1398	18-7102	—	—	—	—	18-0515	—
4.5 (4.5, 45)	1	4107220	& UP	—	—	—	—	18-1398	—	—	—	18-7152	18-1398	—	—
4.5	1	5595532	& UP	—	—	—	—	18-1398	—	—	—	18-7152	18-1398	—	—
6 (60)		1916139	2529894	—	—	—	—	18-1398	—	—	—	18-7459	18-1398	—	—
6		A197112	T800749	—	—	—	—	—	—	—	—	—	—	—	—
7.5 (75)		2529895	5226934	—	—	—	—	18-1398	—	—	—	18-7152	18-1398	—	—
10 (100)		1290910	& UP	—	—	—	—	—	—	—	—	—	—	—	—
10 (MARATHON, XR10, SEAPRO)		D038000	& UP	—	—	—	—	—	—	—	—	—	—	—	—
15 (150)		1290910	1499331	—	—	—	—	—	—	18-2026	18-2026	—	18-1153	—	—
15		B292414	& UP	—	—	—	—	—	—	—	—	—	—	—	—
15 (EXPORT SEAPRO)		G044365	G202749	—	—	—	—	—	—	18-0537	—	—	—	—	—
15 (SEAPRO)		G438000	& UP	—	—	—	—	—	—	—	—	—	—	—	—
15 (SUPER)		B238464	G202749	—	—	—	—	—	—	18-0537	—	—	—	—	—
18		5837437	6239752	—	—	—	—	—	—	18-0537	—	—	—	—	—
20		1558310	2296266	—	—	—	—	—	—	18-2026	18-2026	—	18-1153	—	—
20 (200, 20)		2296267	& UP	—	—	—	—	—	—	—	—	—	—	—	—
25 (KF 9)	4	377150	495761	—	—	—	—	—	—	—	—	—	—	—	—
10 (MK10)	2	1057994	1122327	—	—	—	—	—	—	—	—	—	—	—	—
15 (MK15)	2	1200114	1287384	—	—	—	—	—	—	—	—	—	—	—	—
16 (MK20)	2		ALL	—	—	—	—	—	—	—	—	—	—	—	—
20 (MK25)	2	860979	& UP	—	—	—	—	—	—	—	—	—	—	—	—
22 (MK28)	2	1158546	1238089	—	—	—	—	—	—	—	—	—	—	—	—
30 (MK30)	4		ALL	—	—	—	—	—	—	—	—	—	—	—	—
35 (MK35)	4	1217222	1271884	—	—	—	—	—	—	—	—	—	—	—	—
25 (MK40)	4	711400	& UP	—	—	—	—	—	—	—	—	—	—	—	—
40 (MK50)	4		ALL	—	—	—	—	—	—	—	—	—	—	—	—
40(MK55)	4	831021	& UP	—	—	—	—	—	—	—	—	—	—	—	—
45 (MK58)	4	1139538	& UP	—	—	—	—	—	—	—	—	—	—	—	—
60 (MK75)	6		ALL	18-4037	—	—	—	—	—	—	—	—	—	—	—
70 (MK78)	6	1143038	& UP	18-4037	—	—	—	—	—	—	—	—	—	—	—
3.5 / 3.6 / 3.9	1		ALL	—	—	—	—	18-1398	—	—	—	—	18-1398	—	—
9.8	2	1865779	& UP	—	—	—	—	18-1398	—	—	—	—	18-1398	—	—
20	2	1292910	6443972	—	—	—	—	18-1153	—	—	—	—	18-1153	—	—
20 (20 XD)	2	6443973	B114230	—	—	—	—	—	—	18-0537	—	—	—	—	—
25	2	1467499	1499331	—	—	—	—	—	—	—	—	—	—	—	—
25	2	5705532	6241936	—	—	—	—	—	—	18-0537	—	—	—	—	—
25 (250)		1290910	1499331	—	—	—	—	—	—	—	—	—	—	—	—
30 (300)	4	1271885	1448139	—	—	—	—	18-1154	18-7151	—	18-2016	18-7151	18-1154	—	—
30 (644cc)	2	G053314	D589999	—	18-4039	—	18-4036	18-1154	18-7176	18-2016	—	—	—	—	—
30 (644cc)	2	G590000	T598999	—	18-1194	—	18-4036	—	—	—	—	—	—	—	—
30 JET	4	C159200	& UP	18-4037	—	—	—	18-1154	—	—	—	—	18-1154	—	—

APPLICATION CONTINUED ON NEXT PAGE

HP	Cyl.	Eng. S/N	End S/N	Center Main Bearing	Con. Rod Crank End	Main Valve Block	Con. Rod Piston End	Lower Main Bearing	Lower O-ring	Lower Oil Seal	Lower Oil Seal 2	Upper O-ring	Upper Main Bearing	Upper Oil Seal	Upper Roller Bearing
30 JET	3	G590000	& UP	—	—	—	18-4036	18-1154	—	—	—	—	—	—	—
35 (350, 35A)	4	121722	1448139	—	—	—	—	18-1154	—	—	—	—	18-1154	—	—
35 (350)	2	1571114	1898815	—	—	—	—	18-1154	18-7151	—	—	—	18-1154	—	—
35	2	6445653	B110788	—	18-4038	—	18-4036	18-1154	—	—	—	—	—	—	—
40 (400E, 400M)	4	1279685	1367697	—	—	—	—	18-1154	—	—	—	—	18-1154	—	—
40 (400E, 400M)	4	1384806	1476509	—	—	—	—	—	—	—	—	—	—	—	—
40 (400)	2	2874704	3045259	—	18-4038	—	18-4036	18-1154	18-2016	18-2016	—	—	18-2016	—	—
40 (400)	2	3045260	3336257	—	18-4038	—	18-4036	—	—	—	—	—	—	—	—
40 (402)		3336258	4117709	—	18-4038	—	18-4036	—	—	—	—	—	—	—	—
40 (402, 40)		4117710	5556229	—	18-4038	—	18-4036	—	18-2016	18-2016	—	—	18-2016	—	—
40	2	5556230	6443972	—	18-4038	—	18-4036	—	—	—	—	—	—	—	—
40	2	G053314	& UP	—	18-1194	—	18-4036	18-1154	18-2016	—	—	—	—	—	—
40	3	G531301	& UP	—	18-1194	—	18-4036	18-1154	18-2016	—	—	—	—	—	—
40	4	C159200	& UP	18-4037	—	—	—	18-1154	18-7161	18-2016	—	18-7151	18-1154	—	—
45 (450)	4	1476510	1531568	—	—	—	—	18-1154	—	18-2016	18-7151	18-1154	18-1154	—	—
45	4	5531630	& UP	18-4037	—	—	—	18-1154	18-7151	18-2016	18-7151	18-1154	18-1154	—	—
45 JET		D000750	D589999	—	18-4039	—	18-4036	18-1154	18-7176	18-2016	—	—	—	18-2016	—
45 JET (59 CID)	3	G590000	& UP	—	18-1194	—	18-4036	18-1154	18-7176	18-2016	—	—	—	—	—
50 (500)	4	1421113	1755548	—	—	—	—	18-1154	18-7151	—	18-2016	18-7151	18-1154	18-2016	—
50 (500)		1770179	2305100	—	—	—	—	—	—	—	—	—	—	—	—
50 (500, 50)		2305151	5193253	—	—	—	—	—	—	—	—	—	—	—	—
50	4	5193259	5531629	18-4037	—	—	—	18-1154	—	—	—	—	18-1154	—	—
50	4	5531630	& UP	18-4037	—	—	—	—	—	—	—	—	—	—	—
50	3	6428681	D000749	18-4037	18-4038	—	18-4036	—	18-7161	18-2016	18-2016	18-7415	—	18-2016	—
50	3	D000750	G589999	—	18-4039	—	18-4036	18-1154	18-7176	18-2016	—	—	—	18-2016	—
50	3	G590000	& UP	—	18-1194	—	18-4036	18-1154	18-7176	18-2016	—	—	—	—	—
55	3	D000750	G589999	—	18-4039	—	18-4036	18-1154	18-7176	18-2016	—	—	—	18-2016	—
55	3	G590000	& UP	—	18-1194	—	18-4036	18-1154	18-7176	18-2016	—	—	—	—	—
60 (600)	4	1303411	1542744	18-4037	—	—	—	18-1154	18-7151	—	18-2016	18-7151	18-1154	18-2016	—
60	3	6428681	D000749	18-4037	18-4038	—	18-4036	—	18-7161	18-2016	18-2016	18-7415	—	18-2016	—
60	3	D000750	G589999	—	18-4038	—	18-4036	18-1154	18-7176	18-2016	—	—	—	18-2016	—
60 (59 CID)	3	G590000	& UP	—	18-1194	—	18-4036	18-1154	—	—	—	—	—	—	—
65 (650)	4	1545745	1765043	18-4037	—	—	—	18-1154	18-7151	—	18-2016	—	—	18-2016	—
65 (650)	4	1765044	2119748	18-4037	—	—	—	—	—	—	—	—	—	—	—
65 (650)	4	2119749	2309310	18-4034	—	—	—	—	—	—	—	—	—	—	—
65 (650)	4	2309311	3293183	18-4037	—	—	—	—	—	—	—	—	—	—	—
65 (650)	3	3293184	4571651	18-4037	18-4038	—	18-4036	—	18-7161	18-2016	18-2016	18-7961	—	18-2016	—
65 (650)	3	8006640	8042349	18-4037	18-4038	—	18-4036	—	—	—	—	—	—	—	—
65 (650)	3	9020074	9135824	18-4037	18-4038	—	18-4036	—	—	—	—	—	—	—	—
65 (650)	3	7013633	7087822	18-4037	18-4038	—	18-4036	—	—	—	—	—	—	—	—
65 JET		D283222	& UP	—	—	—	—	18-1346	—	18-2016	—	18-7414	—	18-0523	—
70 (700)	6	1296411	1566239	18-4037	—	—	—	18-1154	18-7151	—	18-2016	18-7151	18-1154	18-2016	—
70	3	4571652	5579016	18-4037	18-4038	—	18-4036	—	18-7161	18-2016	18-2016	18-7415	—	18-2016	—
70	3	5579017	6428680	18-4037	18-4038	—	18-4036	—	—	—	—	—	—	—	—
70 CONNECTING ROD #638-8532-1	3	A996142	C221999	—	—	—	—	18-1346	—	18-2016	—	18-7414	—	18-0523	—
75	4	6432901	& UP	18-4037	18-4038	—	18-4036	18-1154	18-7161	18-2016	18-2016	18-7961	—	18-2016	—
75 CONNECTING ROD #638-8532-1	3	C222000	& UP	—	—	—	—	18-1346	—	18-2016	—	18-7414	—	18-0523	—
75 DFI (1.5L)		T980000	B189548	—	—	—	—	18-1346	—	18-2016	—	—	—	—	—
80 (800)	6	1335465	1566239	18-4037	—	—	—	18-1154	18-7151	—	18-2016	18-7151	18-1154	18-2016	—
80 (800)	4	2559001	2670574	18-4037	18-4038	—	18-4036	18-1154	18-2016	18-2016	18-2016	18-7961	—	18-2016	—
80 (800)	4	2783253	3493912	18-4037	18-4038	—	18-4036	—	—	—	—	—	—	—	—
80 (800, 80)	4	4831999	5582561	18-4037	18-4038	—	18-4036	18-1154	18-7161	18-2016	18-2016	18-7961	—	18-2016	—

APPLICATION CONTINUED ON NEXT PAGE

HP	Cyl.	Beg. S/N	End S/N	Center Main Bearing	Con. Rod Crank End	Main Valve Block	Con. Rod Piston End	Lower Main Bearing	Lower O-ring	Lower Oil Seal	Lower Oil Seal 2	Upper O-ring	Upper Main Bearing	Upper Oil Seal	Upper Roller Bearing
80 (80)	4	5582562	6422900	18-4037	18-4038	—	18-4036	—	—	—	—	—	—	—	—
80 CONNECTING ROD #638-8532-1	3	A996142	C221999	—	—	—	—	18-1346	—	18-2016	—	18-7414	—	18-0523	—
80 JET		D283222	& UP	—	—	—	—	18-1346	—	18-2016	—	18-7414	—	18-0523	—
85 (850, 76 CID)	6	1460999	1464848	18-4037	—	—	—	18-1154	18-7151	—	18-2016	18-2016	—	18-2016	—
85 (850, 90 CID)	6	1566240	1766823	18-4037	—	—	—	18-1345	18-2016	—	18-2016	—	—	18-2016	—
85 (850)	4	3493913	3865694	18-4037	18-4038	—	18-4036	18-1154	18-7161	18-2016	18-2016	18-7961	—	18-2016	—
85 (850)	4	3865695	4831998	18-4037	18-4038	—	18-4036	—	—	—	—	—	—	—	—
90 (900)	6	1766824	1850448	18-4037	—	—	—	18-1154	18-2016	—	18-2016	—	—	18-2016	—
90 (900)	6	1850449	1869775	18-4037	—	—	—	—	—	—	—	—	—	—	—
90 (900, 90)	6	4845301	5594656	18-4037	18-4038	—	18-4036	18-1154	18-7161	18-2016	18-2016	—	—	18-2016	—
90 (90)	6	5594657	& UP	18-4037	18-4038	—	18-4036	—	—	—	—	—	—	—	—
90 (90) CONNECTING ROD #638-8532-1	3	A996142	D283221	—	—	—	—	18-1346	—	18-2016	—	18-7414	—	18-0523	—
95 (950E)	6	1869776	2318585	18-4037	—	—	—	18-1154	18-7151	—	18-2016	—	—	18-2016	—
95 (950E-SS)		1869776	2318585	18-4037	—	—	—	18-1154	18-2016	—	18-2016	—	—	18-2016	—
95 (950E-SS-1)		1869776	2318585	18-4037	—	—	—	—	—	—	—	—	—	—	—
100 (1000)	6	1464949	2318585	18-4037	—	—	—	18-1154	18-7151	—	18-2016	—	—	18-2016	—
100 (1000SS)		2318586	2836018	18-4037	—	—	—	18-1154	18-7151	—	18-2016	—	—	18-2016	—
100 (1000BP)		2399698	2641854	18-4037	—	—	—	—	—	—	—	—	—	—	—
100 (1000BP)		2641855	3253111	18-4037	18-4038	—	18-4036	18-1154	18-7151	18-2016	18-2016	18-7961	—	18-2016	—
100	4	B209468	& UP	—	—	—	—	18-1346	—	—	—	—	—	—	—
105 JET		D820000	& UP	—	18-1194	—	—	18-1345	—	—	—	—	—	—	—
110 (1100E)		1870204	2314955	18-4037	—	—	—	18-1154	18-7151	—	18-2016	—	—	18-2016	—
110 (1100-SS)	6	1870204	2314955	18-4037	—	—	—	18-1154	18-2016	—	18-2016	—	—	18-2016	—
110 (1100E-SS-1)	6	1870204	2314955	18-4037	—	—	—	—	—	—	—	—	—	—	—
115 (1150)	6	2836019	3525440	18-4037	18-4038	—	18-4036	18-1154	18-7151	18-2016	18-2016	18-7961	—	18-2016	—
115 (1150, 115)		3525441	5600966	18-4037	18-4038	—	18-4036	—	—	—	—	—	—	—	—
115	6	5600967	6262960	18-4037	18-4038	—	18-4036	—	—	—	—	—	—	—	—
115	6	6262961	C099999	18-4037	18-4038	—	18-4036	—	—	—	—	—	—	—	—
115 CONNECTING ROD #638-8532-1	4	C100000	D283221	—	—	—	—	18-1346	—	18-2016	—	18-7414	—	18-0523	—
115 OPTIMAX	6	G960500	T178499	—	18-1194	—	—	—	—	—	—	—	—	—	—
125 (1250, 1250BP)	6	2314956	2641954	18-4037	18-4038	—	18-4036	18-1154	18-2016	—	—	18-7961	—	18-2016	—
125 (1250BP)		2641955	3253111	18-4037	18-4038	—	—	—	—	—	—	—	—	—	—
125	4	D283222	& UP	—	—	—	—	18-1346	—	18-2016	—	18-7414	—	18-0523	—
135 (1350)		2839369	3293233	18-4037	18-4038	—	18-4036	18-1154	18-7151	18-2016	18-2016	18-7961	—	18-2016	—
1400		3293234	3502805	18-4037	18-4038	—	18-4036	18-1154	—	—	—	—	—	—	—
1400-140		4865678	& UP	18-4037	18-4038	—	18-4036	—	—	—	—	—	—	—	—
140 JET	V-6	D082000	& UP	—	18-4039	—	—	18-1345	18-0860	18-2016	18-2016	18-0858	—	18-2016	—
V-135 W/ METAL CAGED MAIN BRG	V-6	A904646	C239552	—	18-1194	—	—	—	—	—	—	—	—	—	—
V-135 W/ PLASTIC CAGED MAIN BRG	V-6	A904646	C239552	—	18-1194	—	—	—	—	—	—	—	—	—	—
V-135 CONNECTING ROD #636-8118	V-6	C239553	D082000	—	18-1194	—	—	—	—	—	—	—	—	—	—
V-135	V-6	D082000	& UP	—	18-1194	—	—	—	—	—	—	—	—	—	—
V-135 DFI	V-6	D082000	G760299	—	18-4039	—	—	18-1345	—	—	—	—	—	—	—
V-135 DFI	V-6	G760300	& UP	—	18-1194	—	—	—	—	—	—	—	—	—	—

APPLICATION CONTINUED ON NEXT PAGE

HP	Cyl.	Beg. S/N	End S/N	Center Main Bearing	Con. Rod Crank End	Main Valve Block	Con. Rod Piston End	Lower Main Bearing	Lower O-ring	Lower Oil Seal	Lower Oil Seal 2	Upper O-ring	Upper Main Bearing	Upper Oil Seal	Upper Roller Bearing
1500-1500XS	V-6	3502806	5327662	18-4037	18-4038	—	18-4036	18-1154	18-7161	18-2016	18-2016	18-7961	—	18-2016	—
1500-1500XS	V-6	8005615	8052649	18-4037	18-4038	—	18-4036	—	—	—	—	—	—	—	—
1500-1500XS	V-6	7010533	7112772	18-4037	18-4038	—	18-4036	—	—	—	—	—	—	—	—
V-150 (V-1500)	V-6	4868998	C100860	—	18-4039	—	—	18-1345	—	18-2016	18-2016	—	—	18-2016	18-1196
V-150	V-6	C100861	C239552	—	18-1194	—	—	18-1345	18-0860	18-2016	18-2016	18-0858	—	18-2016	—
V-150 CONNECTING ROD #636-8118	V-6	C239553	D081999	—	18-1194	—	—	18-1345	18-0860	18-2016	18-2016	18-0858	—	18-2016	—
V-150 CONNECTING ROD #644-818141	V-6	C239553	D081999	—	18-1194	—	—	—	—	—	—	—	—	—	—
V-150 DFI	V-6	D082000	& UP	—	18-1194	—	—	18-1345	18-0860	18-2016	18-2016	18-0858	—	18-2016	—
V-150 EFI	V-6	D082000	& UP	—	18-4039	—	—	18-1345	—	—	—	—	—	—	—
150	V-6	4868998	D081999	—	18-1194	—	—	—	—	—	—	—	—	—	—
XR-4	V-6	G760300	& UP	—	18-1194	—	—	—	—	—	—	—	—	—	—
XR-4	V-6	B242885	C239552	—	18-1194	—	—	—	—	—	—	—	—	—	—
XR-4	V-6	C239553	D081999	—	18-1194	—	—	—	—	—	—	—	—	—	—
XR-6	V-6	D082000	& UP	—	18-4039	—	—	18-1345	—	—	—	—	—	—	—
V-175 (1750)	V-6	4301235	6618750	—	18-4039	—	—	18-1345	—	18-2016	18-2016	—	—	18-2016	18-1196
V-175	V-6	6618751	C239552	—	18-1194	—	—	18-1345	18-0860	18-2016	18-2016	18-0858	—	18-2016	—
V-175	V-6	C239553	D081999	—	18-1194	—	—	18-1345	18-0860	18-2016	18-2016	18-0858	—	18-2016	—
V-175	V-6	D082000	& UP	—	18-1194	—	—	—	—	—	—	—	—	—	—
V-175 XRI	V-6	D000750	D081999	—	18-1194	—	—	18-1345	18-0860	18-2016	18-2016	18-0858	—	18-2016	—
V-175 EFI	V-6	D082000	& UP	—	18-4039	—	—	18-1345	—	—	—	—	—	—	—
V-175	V-6	T178500	& UP	—	18-1194	—	—	18-1345	18-0860	18-2016	18-2016	18-0858	—	18-2016	—
DFI & PRO XS															
175 (1750)	V-6	8058870	& UP	—	18-1194	—	—	—	—	—	—	—	—	—	—
V-200 (V2000)	V-6	4839034	5363917	—	18-1194	—	—	18-1345	—	—	—	—	—	—	—
V-200 (V2000)	V-6	5363918	6073191	—	18-1194	—	—	18-1345	—	18-2016	18-2016	—	—	18-2016	18-1196
V-200 (2.4L)	V-6	6073192	C291519	—	18-1194	—	—	18-1345	18-0860	18-2016	18-2016	18-0858	—	18-2016	—
V-200 (2.5L) CONNECTING ROD #636-8118	V-6	C291520	D081999	—	18-1194	—	—	—	—	—	—	—	—	—	—
V-200 (2.5L) CONNECTING ROD #644-818141	V-6	C291520	D081999	—	18-1194	—	—	—	—	—	—	—	—	—	—
V-200	V-6	D082000	& UP	—	18-4039	—	—	18-1345	—	—	—	—	—	—	—
V-200 EFI	V-6	C100861	C291519	—	18-1194	—	—	18-1345	18-0860	18-2016	18-2016	18-0858	—	18-2016	—
V-200 EFI CONNECTING ROD #644-818141	V-6	C291520	D081999	—	18-1194	—	—	—	—	—	—	—	—	—	—
V-200 EFI CONNECTING ROD #636-8118	V-6	C291520	D081999	—	18-1194	—	—	—	—	—	—	—	—	—	—
V-200 EFI (2.5L)	V-6	D082000	B226999	—	18-4039	—	—	18-1345	—	—	—	—	—	—	—
V-220	V-6	B117316	& UP	—	18-1194	—	—	—	—	—	—	—	—	—	—
V-225	V-6	5628028	D280812	—	18-1194	—	—	18-1345	18-0860	18-2016	18-2016	—	—	18-2016	—
V-225 (225, SEAPRO)	V-6	D280813	& UP	—	18-4039	—	—	18-1345	—	—	—	—	—	—	—
V-225 DFI	V-6	G590000	T325116	—	—	—	—	18-1345	18-0860	—	—	18-7414	—	—	—
V-225	V-6	G129222	& UP	—	—	—	—	18-1345	18-0860	—	—	18-7414	—	—	—
V-250 EFI	V-6	G129222	T325116	—	—	—	—	18-1345	18-0860	—	—	18-7414	—	—	—
V-250	V-6	C101891	& UP	—	18-4039	—	—	18-1345	—	—	—	18-7414	—	18-2016	—
V-250 DFI & PRO XS	V-6	B528615	& UP	—	—	—	—	18-1345	18-0860	—	—	18-7414	—	—	—
V-275	V-6	C101891	& UP	—	—	—	—	—	—	—	—	18-7414	—	—	—
V-3.4L	V-6	5611648	& UP	—	18-4039	—	—	18-1345	—	—	—	18-7414	—	—	—

 <p>18-2143 MOTOR MOUNT Replaces: 67210, 78249 Large Diameter Lower Motor Mount Includes: (1) Lower Motor Mount and (2) 1 1/4" O.D. x 1/2" I.D. Stainless Steel Washers</p>	 <p>18-2144 MOTOR MOUNT Replaces: 67209, 77326, 78687, 78687T Small Diameter Upper Motor Mount Includes: (1) Upper Motor Mount and (1) 1 1/4" O.D. x 1/2" I.D. Stainless Steel Washer</p>	 <p>18-7901 OIL FILTER Replaces: 825467A1, T1 For: 9.9HP S/N OH000058-OH017099 (1995-98)</p>	 <p>18-7758 OIL FILTER Replaces: 35-877761K01, 35-877761Q01 For: 75/90/115 hp. (S/N 1B366823 (2006) & Up)</p>
---	---	--	--

 <p>18-7918 OIL FILTER Replaces: 35-883701K01, 35-877769K01 For: Verado 200-300 HP, Inline 6 cylinder</p>	 <p>18-7921 OIL FILTER Replaces: 35-896546T, 35-877767K01 For: Verado 135-200 HP, Inline 4 cylinder</p>	 <p>18-7906-1 OIL FILTER Replaces: 35-822626T7, 35-822626Q15, 35-8226267 Fits: 225 HP (Non-Verado)</p>
--	---	---

 <p>18-7913 OIL FILTER Replaces: 35-822626Q1 For: 8 HP (323cc) 2001-2004 / 9.9 HP (323cc) 1999-2004 / 15 HP, (323cc) 1998 and NEWER / 20 HP, 2008 and NEWER / 30 HP (492cc) 2006 and NEWER</p>	 <p>18-7914 OIL FILTER Replaces: 35-822626Q2, 35-822626Q04, 35-877768K01, 35-822626K04, 35-822626T2, 35-8M0064104, 35-8M0008397 For: 25 HP, (498cc) 1998-2005 / 30 HP, (747cc) 1999-2005 / 40, 50, 60 HP, 1995 and NEWER / 75, 90 Carbureted 2000-2005 / 115 EFI (S/N 1B366822 and BELOW)</p>	 <p>NEW 18-1800 OIL RESERVIOR FLOAT SWITCH Replaces: 12886A6</p>
--	--	---

NEW TIMING BELTS

Sierra Timing Belts provide extended durability and smoother performance characteristics required by today's marine engines.

FEATURES:

- Neoprene or Nitrile construction for maximum durability based on application
- Positive Slip Proof engagement
- Fiberglass tension member for excellent flex and elongation behavior
- Chemical and Contaminant Resistance for Long Life
- Meets or Exceeds OEM belt specifications
- Modified Curvilinear or Trapezoidal tooth profile for direct OE fitment/replacement
- Recommended periodic maintenance interval of 5 years or 1000 hours of use (Note: Timing belt should be inspected every 100 hours and replaced as necessary.)
- Inexpensive insurance to prevent catastrophic engine failure



Part No.	Replaces	Fits
18-15146	8M0072670	25 HP EFI (3 CYL) Fourstroke 0R106999 and Above; 25 HP JET EFI (3 CYL) 0R165086 and Above; 30 HP EFI (3 CYL) Fourstroke 0R106999 and Above
18-15147	835392Q	9.9 HP Fourstroke 0G760300-1B226999; 15 HP Fourstroke 1B227000-1B727495; 15 HP Fourstroke 0G760300-1B226999
18-15148	8M0065179	40 HP (3 CYL) Fourstroke 1C049739 and Above; 40-50-60 HP Fourstroke 1C050252 and Above
18-15149	57-895120	8 HP Fourstroke 0R042475 and Above; 9.9 HP Fourstroke 0R042475 and Above
18-15150	57-895120002	10 HP Carb (2 CYL) Fourstroke 0R575531-0R833819; 15 HP Carb (2 CYL) Fourstroke 0R235949-0R833819; 15 HP Carb Fourstroke JCI 0R558208-0R833819; 15 HP SEAPRO Fourstroke 0R051685-0R123564; 15 HP SEAPRO Fourstroke 0R123565 and Above; 20 HP Carb (2 CYL) Fourstroke 0R235168-0R833819

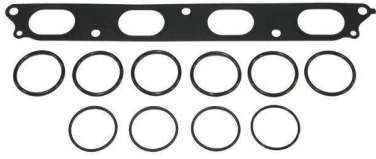

18-0663
PLENUM GASKET KIT
 Fits: Mercury 75 4-Stroke (2000-03),
 90 4-Stroke (2000 & Up),

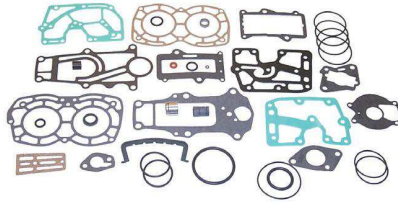

18-4334
POWERHEAD GASKET SET
 Replaces: 27-41499A87
 For: 15HP, 18HP, 20HP & 25HP outboards

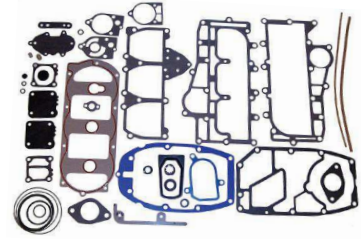

18-4326
POWERHEAD GASKET SET
 Replaces: 27-43779A87
 For: 50,55,60 HP, 3 cyl.

— CONTAINS —

Part #	Desc.	O.E.#	Qty.
18-4261	Fiber Washer	19643	1
18-0320	Gasket	27-13937-6	6
18-0324	Gasket	27-15172-3	3
18-0670	Gasket	27-43007 5	1
18-2565	Gasket	27-43047-1	1
18-2945	Washer	12-20260	3
18-7164	O-Ring	25-33466	1
18-7198	O-Ring	25-45710	1
18-7167	O-Ring	25-45254	1
18-0182	Gasket	27-62386	1
18-2740	Cylinder Block Gasket	27-43005 7	1
18-2741	Gasket	27-43004 7	2
18-0339	Thermostat Gasket	27-43006-2	1
18-0341	Exhaust Gasket	27-43008, 27-430082, 27-430083, 27-430085	1
18-2563	Gasket	27-43034-1	1
18-2564	Gasket	22-43033-1	1
18-2566	Impeller Gasket	27-817277	1
18-7105	O-Ring	25-62705	2
18-7414	O-Ring	25-64067	1
18-0858	O-Ring	25-54029	1
18-7803	Diaphragm Kit	21-857005A1	1

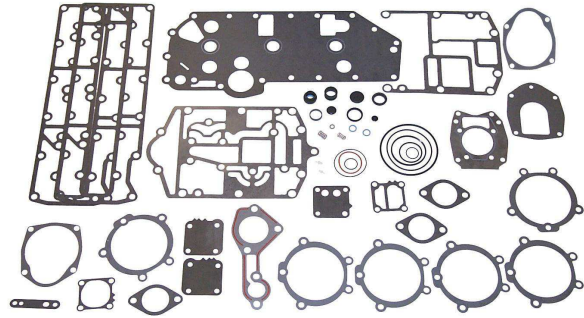

18-4336
POWERHEAD GASKET SET
 Replaces: 27-43004A99, 27-43004A90, 27-43004A86
 For: 70, 80, 90HP 3 cyl outboards

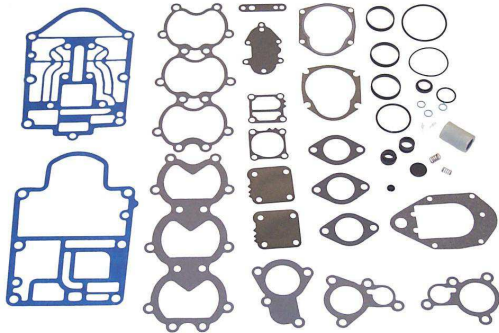

18-4337
POWERHEAD GASKET SET
 Replaces: 27-812867A97, 27-812867A96, 27-812867A91
 For: 45 Jet, 50HP, 55HP, 60HP, 3 cyl outboards

CONTAINS —

Part #	Desc.	O.E.#	Qty.
18-7152	O-Ring	25-20863	1
18-2244	Washer	10-79953A2	3
18-7173	O-Ring	25-30224	1
18-0182	Thermostat Gasket	27-62386	1
18-2719	Induction Manifold Gasket	27-812869	1
18-2721	Adapter Plate Gasket	27-827284	1
18-2729	Thermostat Cover Gasket	27-812867 2	1
18-2749	Thermostat Gasket	27-812867 1	1
NSS	Exhaust Gasket	27-812866	1
18-0319	Exhaust Cover Gasket	27-828533	1
18-0622	Lower Wear Plate Gasket	27-19701	1
18-0345	Water Pump Gasket	27-722189	1
18-2593	Water Pump Gasket	N/A	1
18-2566	Impeller Gasket	27-817277	1
18-7176	O-Ring	25-90011	1
18-7950	O-Ring	25-45258	1
18-7817	Diaphragm Kit	21-857005A1	1



18-4338
POWERHEAD GASKET SET
 Replaces: 27-814754A00
 For: V-135, V-150 DFI outboards

CONTAINS —

Part #	Desc.	O.E.#	Qty.
18-2506-1	Exhaust Plate Gasket	27-99176-3	1
18-0860	O-Ring	25-62700	1
18-0858	O-Ring	25-54029	1
18-0182	Thermostat Gasket	27-62386	2
18-0642	Divider Plate Gasket	27-19050-3	1
18-2735	Divider Plate Gasket	27-190506	1
18-0936	Gasket	27-78690	2
18-2511	Gasket	27-99173-2	1
18-0643	Powerhead Base Gasket	27-183071	1
18-2919	Gasket	27-42631-1	1
18-7176	O-Ring	25-90011	1
18-2914	Water Pump Gasket	27-85608-1	1
18-2915	Water Pump Gasket	27-85609-1	1
18-7159	O-Ring	25-31534	1
18-7153	O-Ring	25-25439	1
18-7174	O-Ring	25-45711	2
18-0970	Fuel Pump Gasket	27-98769-1	1
18-0135	Adapter Cover Gasket	27-78246	1
18-2514	Crankcase Gasket	27-53650	2

GASKET SET APPLICATION BEGINS ON PAGE 418
 *POWERHEAD GASKET SETS DO NOT INCLUDE HEAD GASKETS

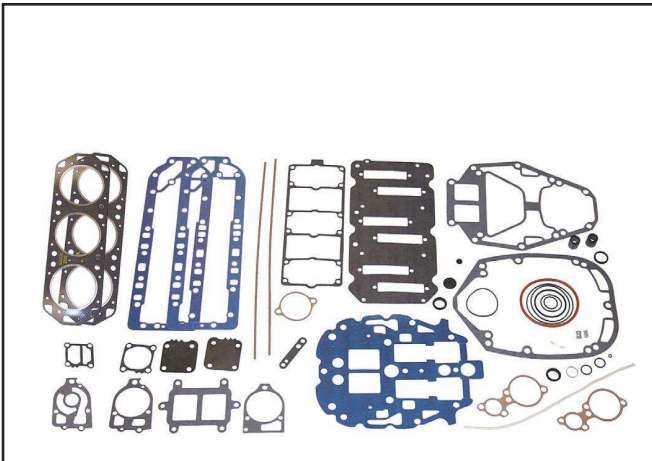

**18-4339
POWERHEAD GASKET SET**

Replaces: 27-14697A87
For: V200EFI and V220 outboards

CONTAINS —			
Part #	Desc.	O.E.#	Qty.
18-3862	Head Gasket	27-41246-1	2
18-7153	O-Ring	25-21836	1
18-7164	O-Ring	25-33466	1
18-7159	O-Ring	25-31534	1
18-0135	Gasket	27-78246	1
18-7426	Slinger	25-30271	1
18-0182	Gasket	27-62386	2
18-0860	O-Ring	25-62700	1
18-0936	Gasket	27-78690	2
18-2919	Gasket	27-42631-1	1
18-2915	Gasket	27-85609-1	1
18-2506-1	Exhaust Plate Gasket	27-99176-3	1
18-2503	Drive Shaft Gasket	27-99177-1	1
18-2513	Cork	27-11338	2
18-0644	Reed Plate Gasket	27-14697-2	1
18-0645	Gasket	27-16737-1	1
18-2502	Gasket	27-90484-1	2
18-2511	Gasket	27-99173-2	1
18-2914	Gasket	27-85608-1	1
18-3110	Grommet	26-38970	2
18-7174	O-Ring	25-45711	2
18-7176	O-Ring	25-90011	1
18-8305	Divider Plate Seal	26-814754	1
18-0858	O-Ring	25-54029	1
18-0952	Gasket	27-88907	1
18-7421	O-Ring	25-20415	1
18-0970	Fuel Pump Gasket	27-98769-1	1
18-7817	Diaphragm Kit	21-857005A1	1

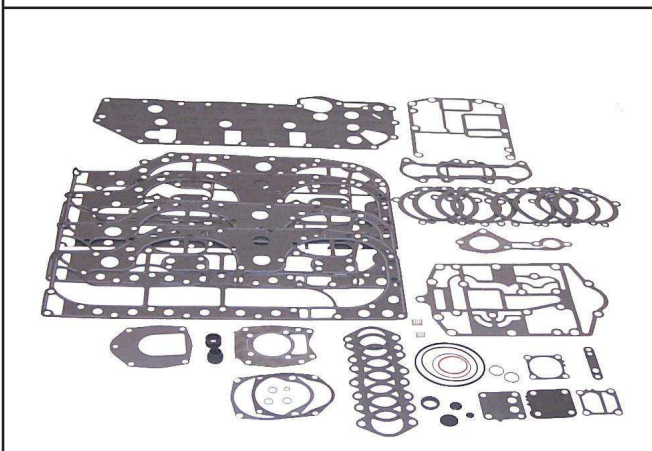

**18-4340
POWERHEAD GASKET SET**

Replaces: 27-13461A99, 27-13461A90, 27-13461A89, 27-13461A88
For: 80 Jet, 100HP, 115HP, and 125HP 4 cyl outboards

CONTAINS —			
Part #	Desc.	O.E.#	Qty.
18-4261	Fiber Washer	19643	1
18-7961	O-Ring	25-47254	1
18-0320	Gasket	27-13937-6	8
18-0324	Gasket	27-15172 4	8
18-0670	Gasket	27-43007-5	1
18-2565	Gasket	27-43047-2	1
18-2945	Washer	12-19183	3
18-7198	O-Ring	25-45710	1
18-0182	Gasket	27-62386	1
NSS	Gasket	27-13461-2	2
18-2943	Cylinder Block Gasket	27-44328-4	1
18-2621	Outer Exhaust Plate Gasket	27-13958-1	2
18-2610	Baffle Plate Gasket	27-812775-4	1
18-2611	Inner Exhaust Plate Gasket	27-812775-5	1
18-0339	Thermostat Gasket	27-43006-2	1
18-0341	Exhaust Gasket	27-43008-6, 27-43008, 27-430082, 27-430083, 27-430085	1
18-2563	Gasket	27-43034-1	1
18-2564	Gasket	27-43033-1	1
18-2566	Impeller Gasket	27-817277	1
18-7105	O-Ring	25-62705	1
18-7414	O-Ring	25-64067	1
18-0858	O-Ring	25-54029	1
18-0970	Fuel Pump Gasket	27-98769-1	1
18-7817	Diaphragm Kit	21-857005A1	1

— CONTAINS —			
Part #	Desc.	O.E.#	Qty.
18-0182	Thermostat Gasket	27-62386	2
18-0858	O-Ring	254029	1
18-0860	O-Ring	25-62700	1
18-0129	Reed Block Gasket	27-65744-3	6
18-0135	Adapter Cover Gasket	27-78246	1
18-0936	Relief Valve Plate Gasket	27-78690	2
18-0952	Relief Valve Plate Gasket	27-88907	2
18-7421	O-Ring	25-20415	2
18-7411	O-Ring	25-35480	1
18-2501	Reed Block Housing Gasket	27-93536-1	1
18-2502	Divider Plate Gasket	27-90484-1	2
18-2503	Drive Shaft Hsg. to Exhaust Plate Gasket	27-99177-1	1
18-2506	Exhaust Plate Gasket	27-99176-3	1
18-2508	Exhaust Plate Gasket	27-99776-1	2
18-2509	Carb. Mtg. Gasket	27-67751	3
18-2510	Reed Block Housing Gasket	27-96761-1	1
18-2511	Drive Shaft Housing to Plate Gasket	27-99173-2	1
18-2513	Cyl Block Sealing Gasket	27-11338	2
18-2803	Carb. Mounting Gasket	27-90430	3
18-2808	Cyl. Cover	27-96278	2
18-2826	Water Pump Base to Gear Housing Gasket	27-85610-1	1
18-2914	Water Pump Gasket	27-85608-1	1
18-2915	Water Pump Gasket	27-85609-1	1
18-3110	Bushing	26-38970	2
18-7153	O-Ring	25-25439	1
18-7157	O-Ring	25-29976	1
18-7159	O-Ring	25-31534	1
18-7162	O-Ring	25-33145	1
18-7164	O-Ring	25-33466	1
18-7168	O-Ring	25-48171	4
18-7174	O-Ring	25-45711	2
18-7176	O-Ring	25-90011	1
18-7812	Fuel Pump Kit	89031A2	1
18-3863	Head Gasket	27-96542-1	2
18-0359	Induction Silencer Cover Gasket	27-67275-1	1
18-0384	Carburetor Gasket	27-89221-1	3
18-2919	Water Pump Gasket	27-42631-1	1
18-7406	O-Ring	—	1

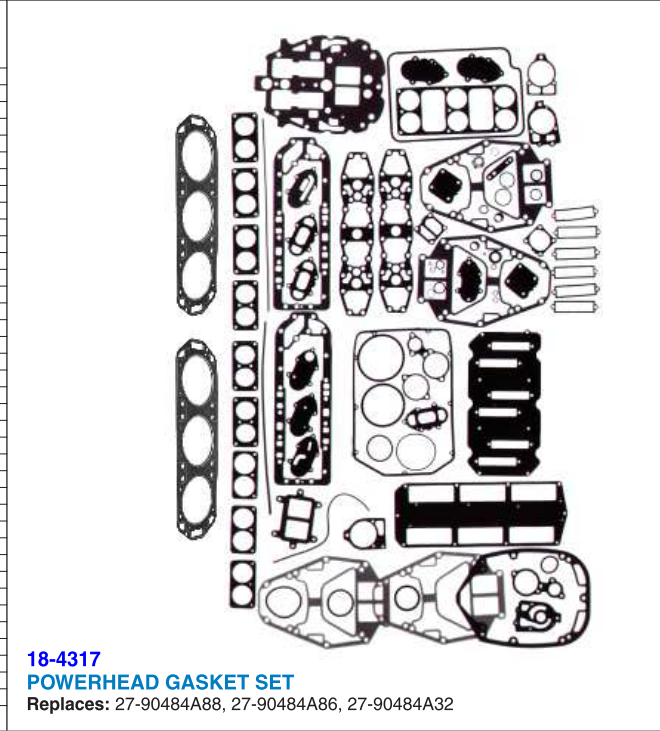

**18-4317
POWERHEAD GASKET SET**
Replaces: 27-90484A88, 27-90484A86, 27-90484A32

GASKET SET APPLICATION BEGINS ON PAGE 418
*POWERHEAD GASKET SETS DO NOT INCLUDE HEAD GASKETS

— CONTAINS —

Part #	Desc.	O.E.#	Qty.
18-0182	Thermostat Gasket	27-62386	2
18-0858	O-Ring	254029	1
18-0860	O-Ring	25-62700	1
18-0129	Reed Block Gasket	27-65744-3	6
18-0135	Adapter Cover Gasket	27-78246	1
18-0936	Relief Valve Plate Gasket	27-78690	2
18-0952	Relief Valve Plate Gasket	27-88907	2
18-7421	O-Ring	25-20415	2
18-7411	O-Ring	25-35480	1
18-2501	Reed Block Hsg. Gasket	27-93536-1	1
18-2502	Divider Plate Gasket	27-90484-1	2
18-2503	Drive Shaft Hsg. to Exhaust Plate Gasket	27-99177-1	1
18-2506	Exhaust Plate Gasket	27-99176-3	1
18-2508	Exhaust Plate Gasket	27-99776-1	2
18-2509	Carb. Mtg. Gasket	27-67751	3
18-2510	Reed Block Hsg. Gasket	27-96761-1	1
18-2511	Drive Shaft Hsg. to Plate Gasket	27-99173-2	1
18-2513	Cyl Block Sealing Gasket	27-11338	2
18-2803	Carb. Mtg. Gasket	27-90430	3
18-2808	Cyl. Cover	27-96278	2
18-2826	Water Pump Base to Gear Housing Gasket	27-85610-1	1
18-2914	Water Pump Gasket	27-85608-1	1
18-2915	Water Pump Gasket	27-85609-1	1
18-3110	Bushing	26-38970	2
18-7153	O-Ring	25-25439	1
18-7157	O-Ring	25-29976	1
18-7159	O-Ring	25-31534	1
18-7162	O-Ring	25-33145	1
18-7164	O-Ring	25-33466	1
18-7168	O-Ring	25-48171	4
18-7174	O-Ring	25-45711	2
18-7176	O-Ring	25-90011	1
18-7812	Fuel Pump Kit	89031A2	1
18-3862	Head Gasket	27-41246-1	2
18-0359	Induction Silencer Cover Gasket	27-67275-1	1
18-0384	Carburetor Gasket	27-89221-1	3
18-2919	Water Pump Gasket	27-42631-1	1
18-7406	O-Ring	—	1
18-7176	O-Ring	25-90011	1

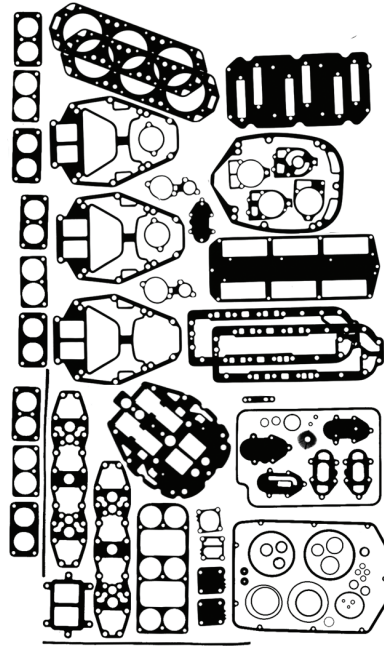

**18-4319
POWERHEAD GASKET SET**

Replaces: 27-11338A88, 27-89221A88, 27-89221A85, 27-89221A84, 27-89221A32, 27-11338A85

— CONTAINS —

Part #	Desc.	O.E.#	Qty.
18-0940	Baffle Plate to Exhaust Gasket	27-85488-2	1
18-0879	Adapter Plate Gasket	27-38501-1	1
18-2810	Block Cover Gasket	27-43777-2	1
18-0103	Powerhead to Ext. Plate Gasket	27-79650-1	2
18-0137	Baffle Plate Gasket	27-85492-2	1
18-2800	Carb. Flange Gasket	27-75791-1	2
18-0870	Transfer Port Cover Gasket	27-27936-1	2
18-0539	Rubber Seal Gasket	37721	1
18-7161	O-Ring	25-32546	1
18-2844	Thermostat Gasket	27-48818-1	1
18-2823	Lower Water Pump Base to Face Plate Gasket	27-19553	1
18-0938	Water Inlet Tube Gasket	27-79797-1	1
18-2825	Water Pump Base Gasket	27-32771	1
18-7153	O-Ring	25-25439	1
18-7151	O-Ring	25-20081	1

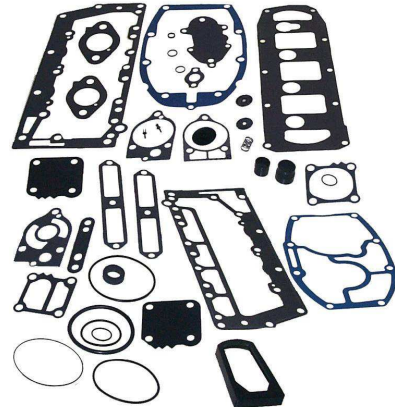

***18-4325
POWERHEAD GASKET SET**

Replaces: 27-85491A90, 25-85491A87

— CONTAINS —

Part #	Desc.	O.E.#	Qty.
18-0912	Drive Shaft Hsg. Plate Gasket	27-66102-1	1
18-0133	Water Jacket Cover Gasket	27-73665	1
18-0944	Water Jacket Cover Gasket	27-85496-1	1
18-0107	Exhaust Cover Gasket	27-85498-1	1
18-7421	O-Ring	25-20415	1
18-3110	Grommet	26-38970	2
18-7411	O-Ring	25-35480	1
18-2500	VC Gasket	27-85493	1
18-2514	Crankcase to Cyl Block Gasket	27-53650	2
18-2802	Carb. Flange Gasket	27-48164-1	2
18-2826	Water Pump Base to Gear Housing Gasket	27-85610	1
18-2835	Powerhead Gasket	27-69238	1
18-2914	Water Pump Gasket	27-85608	1
18-2915	Water Pump Gasket	27-85609-1	1
18-7153	O-Ring	25-25439	1
18-7157	O-Ring	25-29976	1
18-7161	O-Ring	25-32546	1
18-7162	O-Ring	25-33145	1
18-7167	O-Ring	25-47254	2
18-7807	Fuel Pump Kit	55278A1	1
18-0351	Distributor Cap Gasket	27-55896	1
18-7426	O-Ring	25-30271	1
18-4261	Washer	19643	1

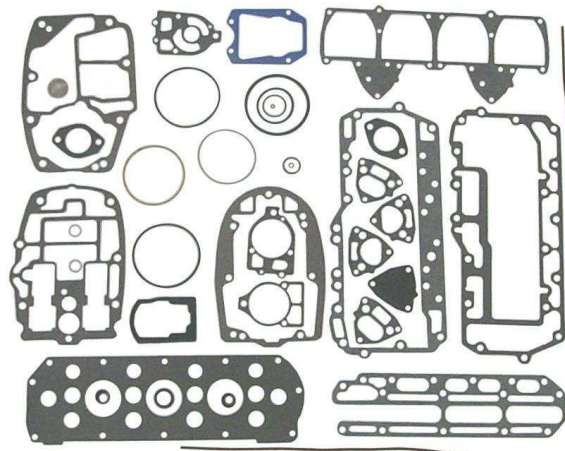

***18-4351
POWERHEAD GASKET SET**

Replaces: 27-64203A75, 27-64203A74, 27-64203A73

GASKET SET APPLICATION BEGINS ON PAGE 418
*POWERHEAD GASKET SETS DO NOT INCLUDE HEAD GASKETS

— CONTAINS —

Part #	Desc.	O.E.#	Qty.
18-0870	Transfer Port Cover Gasket	27-27936-1	2
18-0879	Adapter Plate Gasket	27-30501-1	1
18-0103	Powerhead to Ext. Plate Gasket	27-79650-1	2
18-0938	Water Inlet Tube Gasket	27-79797-1	1
18-0942	Baffle Plate Gasket	27-85491-2	1
18-0137	Baffle Plate Gasket	27-85492-2	1
18-7421	O-Ring	25-20415	1
18-2507	Cyl Block Cover Gasket	27-85487	1
18-2800	Carb. Flange Gasket	27-75791-1	2
18-2810	Block Cover Gasket	27-43777-2	1
18-2823	Lower Water Pump Base to Face Plate Gasket	27-32769, 27-19553	1
18-2824	Upper Face Plate to Pump Body Gasket	27-32770, 27-19551	1
18-2825	Water Pump Base Gasket	27-32771	1
18-2841	Water Pump Base Gasket	27-77417, 27-19552	1
18-7151	O-Ring	25-20081	2
18-7153	O-Ring	25-25439	1
18-7115	O-Ring	25-26722	1
18-7155	O-Ring	25-26855	1
18-7160	O-Ring	25-31986	1
NSS	O-Ring	25-29619	1
18-7413	O-Ring	25-62702	2
18-7804	Fuel Pump Kit	23014A1	1
18-2571	Carb Flange Gasket	27-31402	2

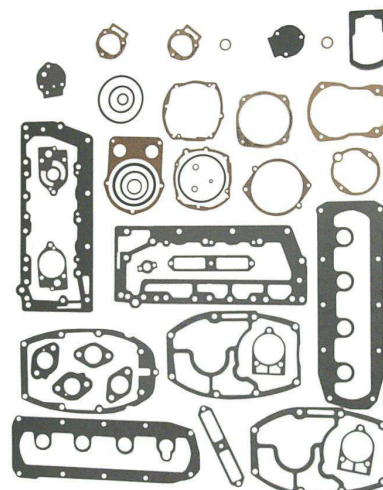

***18-4353
POWERHEAD GASKET SET**
Replaces: 27-72486A32, 27-72486A79, 27-72486A78, 27-72486A76, 27-46110A72, 27-46110A2, 27-46110A1

— CONTAINS —

Part #	Desc.	O.E.#	Qty.
18-0912	Drive Shaft Hsg. Plate Gasket	27-66102-1	1
18-0926	Transfer Port Cover Gasket	27-73645	1
18-0133	Water Jacket Cover Gasket	27-73665	1
18-0101	Carb. Plate Gasket	27-76952	2
18-0944	Baffle to Exchange Cover Gasket	27-85496-1	1
18-0107	Exhaust Cover Gasket	27-85498-1	1
18-7421	O-Ring	25-20415	1
18-3110	Grommet	26-38970	1
18-7411	O-Ring	25-35480	2
18-2500	Exhaust Cover Gasket	27-85493	1
18-2505	Cyl Block Cover Gasket	27-96171-1	1
18-2514	Crankcase to Cyl Block Gasket	27-53650	2
18-2804	Carb. Flange Gasket	27-73377-1	2
18-2826	Water Pump Base to Gear Housing Gasket	27-85610-1	1
18-2835	Powerhead Gsk	27-69238-1	1
18-2914	Water Pump Gasket	27-85608-1	1
18-2915	Water Pump Gasket	27-85609-1	1
18-7153	O-Ring	25-25439	1
18-7157	O-Ring	25-29976	1
18-7161	O-Ring	25-32546	2
18-7162	O-Ring	25-33145	1
18-7164	O-Ring	25-33466	1
18-7167	O-Ring	25-47254	2
18-7413	O-Ring	25-62702	2
18-7808	Fuel Pump Kit	55278A5	1
18-7426	O-Ring	25-30271	1
18-4261	Washer	19643	1

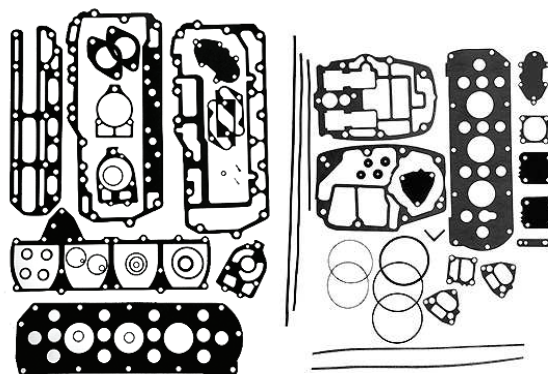

***18-4354
POWERHEAD GASKET SET**
Replaces: 27-73645A87, 27-73645A76, 27-73645A32

— CONTAINS —

Part #	Desc.	O.E.#	Qty.
18-0182	Thermostat Gasket	27-62386	1
18-0879	Adapter Plate Gasket	27-38501-1	1
18-0988	Powerhead to Plate Gasket	27-62860-1	1
18-0914	Thermostat Cover Gasket	27-66847	1
18-0938	Water Inlet Tube Gasket	27-79797-1	1
18-0940	Baffle Plate to Exhaust Gasket	27-85488-2	1
18-0105	Baffle Plate to Block Gasket	27-85489-2	1
18-7421	O-Ring	25-20415	1
18-7411	O-Ring	25-35480	1
18-2802	Carb Flange Gasket	27-48164-1	1
18-2805	Block Cover Gasket	27-85490-2	1
18-2823	Lower Water Pump Base to Face Plate Gasket	27-19553	1
18-2824	Upper Face Plate to Pump Body Gasket	27-19551	1
18-2825	Water Pump Base Gasket	27-32771	1
18-2838	Transfer Port Cover Gasket	27-55279-1	1
18-2841	Water Pump Base Gasket	27-19552	1
18-7115	O-Ring	25-26722	1
18-7143	O-Ring	25-65936	2
18-7145	O-Ring	25-64068	3
18-7153	O-Ring	25-25439	1
18-7155	O-Ring	25-26855	1
18-7160	O-Ring	25-31986	1
18-7167	O-Ring	25-47254	1
18-7413	O-Ring	25-62702	3
18-7414	O-Ring	25-64067	1
18-7807	Fuel Pump Kit	55278A1	1
18-4261	Washer	19643	1

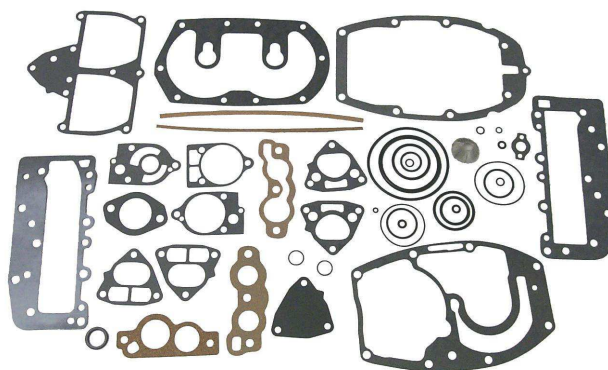

***18-4355
POWERHEAD GASKET SET**
Replaces: 27-78028A78, 27-55306A75, 27-55306A74, 27-55306A73, 27-55306A72

GASKET SET APPLICATION BEGINS ON PAGE 418
***POWERHEAD GASKET SETS DO NOT INCLUDE HEAD GASKETS**

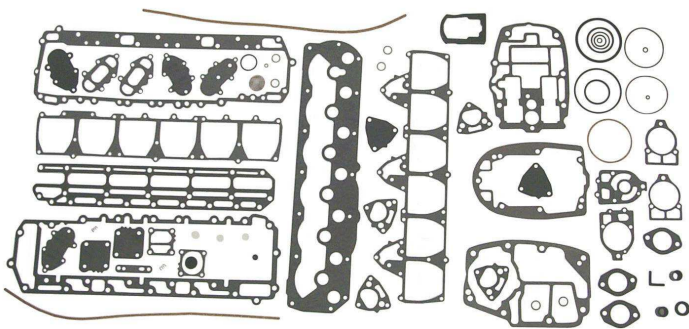

***18-4356**

POWERHEAD GASKET SET

Replaces: 27-85653A87, 27-85653A79, 27-85653A32, 27-60476A75, 27-60476A74, 27-60476A73, 27-60476A72

— CONTAINS —			
Part #	Desc.	O.E.#	Qty.
18-7153	O-Ring	25-25439	1
18-7120	O-Ring	25-38933	1
18-3110	Bushing	26-38970	2
18-7164	O-Ring	25-33466	1
18-7167	O-Ring	25-47254	1
18-2802	Carb. Flange Gasket	27-48164-1	3
18-7413	O-Ring	25-62702	2
18-7161	O-Ring	25-32546	2
18-7173	O-Ring	25-30224	1
18-3110	Grommet	26-38970	1
18-7421	O-Ring	25-20415	1
18-7162	O-Ring	25-33145	1
18-7157	O-Ring	25-29976	1
18-2914	Water Pump Gasket	27-85608-1	1
18-2915	Water Pump Gasket	27-85609-1	1
18-2801	Water Pump Gasket	27-32438	1
18-2826	Water Pump Base to Gear Housing Gasket	27-85610-1	1
18-0912	Drive Shaft Hsg. Gasket	27-66102-1	1
18-2573	Water Jacket Cover Gasket	27-72142-1	1
18-2574	Exhaust Cover Gasket	27-85495-2	1
18-0946	Transfer Port Gasket	27-85653-1	1
18-2513	Crankcase to Cyl. Block Gasket	27-53862	2
18-2807	Block Cover Gasket	27-98185	1
18-2835	Powerhead Gasket	27-69238-1	1
18-2839	Exhaust Cover	27-85497-2	1
18-7807	Fuel Pump Kit	55278A1	2
18-7813	Fuel Pump Kit	89031A3	1
18-7426	O-Ring	25-30271	1

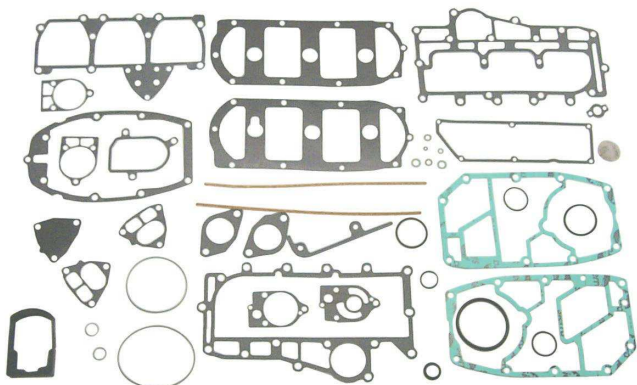

***18-4357**

POWERHEAD GASKET SET

Replaces: 27-88449A32, 27-88449A80, 27-76589A79, 27-76589A78, 27-76589A77, 27-73440A76

— CONTAINS —			
Part #	Desc.	O.E.#	Qty.
18-0182	Thermostat Gasket	27-62386	1
18-0879	Adapter Plate Gasket	27-38501-1	1
18-0904	Powerhead to Exhaust Gasket	27-60317	1
18-0918	Plate to Exhaust Manifold Gasket	27-69524-2	1
18-0131	Baffle Plate Gasket	27-69525-2	1
18-0922	Baffle Plate Gasket	27-70335-1	1
18-0932	Transfer Passage Cover Gasket	27-76862-1	1
18-0938	Water Inlet Tube Gasket	27-79797-1	1
18-0139	Powerhead to Exhaust Plate Gasket	27-88451-1	1
18-7421	O-Ring	25-20415	1
18-2945	Drain Gasket	12-20260	2
18-7411	O-Ring	25-35480	1
18-2504	Block Cover Gasket	27-88449	1
18-2512	Crankcase to Cyl. Block Gasket	27-60286	2
18-2804	Carb. Flange Gasket	27-73377-1	2
18-2809	Block Cover Gasket	27-43779-2	1
18-2823	Lower Water Pump Base to Face Plate Gasket	27-19553	1
18-2824	Upper Face Plate to Pump Body Gasket	27-19551	1
18-2825	Water Pump Base Gasket	27-32771	1
18-2841	Water Pump Base Gasket	27-19552	1
18-7143	O-Ring	27-77417	1
18-7153	O-Ring	25-25439	1
18-7115	O-Ring	25-26722	1
18-7155	O-Ring	25-26855	1
18-7160	O-Ring	25-31986	1
18-7161	O-Ring	25-32546	1
18-7413	O-Ring	25-62702	2
18-7415	O-Ring	25-64966	1
18-7809	Fuel Pump Kit	55278A4	1
18-4261	Washer	19643	1

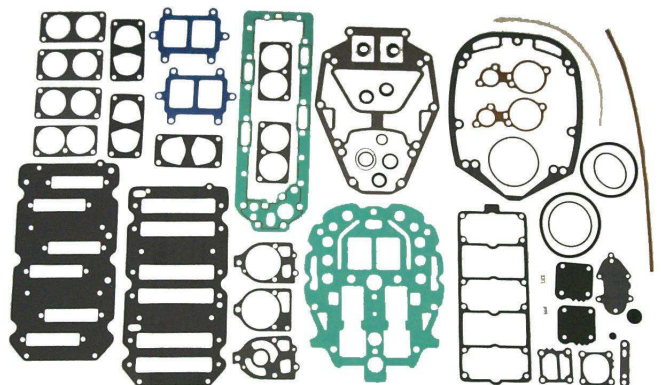

***18-4359**









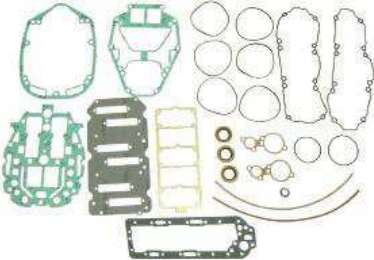
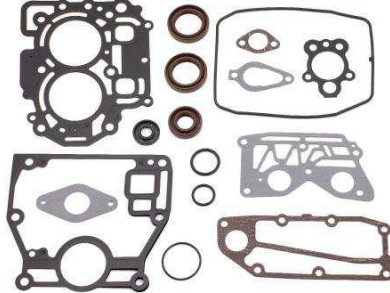
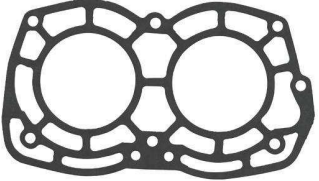

POWERHEAD GASKET SET

Replaces: 27-815791A92, 27-815792A90, 27-815810A90, 27-815809A90

— CONTAINS —			
Part #	Desc.	O.E.#	Qty.
18-0135	Gasket, Adapter	27-78246	1
18-0182	Gasket, Thermostat	27-62386	2
18-0384	Gasket, Carburetor	27-89221-1	3
18-0641	Gasket, Carb Mounting	27-828292	3
18-0642	Gasket, Divider Plate	27-19050-3	1
18-0643	Gasket, Exh. Plate	27-18307-1	1
18-0644	Gasket, Reed Plate	27-14697-2	1
18-0645	Gasket, Adapter Plate	27-16737-1	1
18-0646	Gasket, Reed Plate	27-813859	1
18-0838	O-Ring	—	1
18-0858	O-Ring	25-54029	1
18-0860	O-Ring	25-62700	1
18-0936	Gasket, Relief Valve	27-78690	2
18-2506	Gasket, Pwr Head	27-99176-3	1
18-2509	Gasket, Carb Mounting	27-67751	3
18-2511	Gasket, Drive Shaft To Hsg Plate	27-99173-2	1
18-2513	Gasket, Crankcase Cvr.	27-11338	2
18-2914	Gasket, Water Pump	27-85608-1	1
18-2915	Gasket, Water Pump	27-85609-1	1
18-2919	Gasket, Water Pump	27-42631-1	1
18-3110	Seal	26-38970	2
18-7153	O-Ring	25-25439	1
18-7157	O-Ring	25-29976	1
18-7159	O-Ring	25-31534	1
18-7174	O-Ring	25-45711	1
18-7176	O-Ring	25-90011	1
18-8305	Seal, Divider Plate	26-814754	1

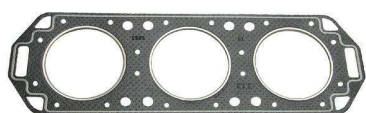
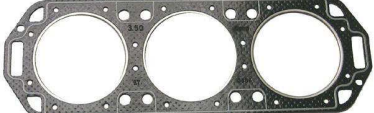
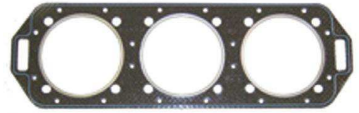
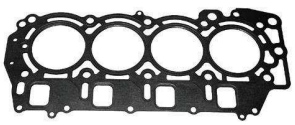
GASKET SET APPLICATION BEGINS ON PAGE 418

*POWERHEAD GASKET SETS DO NOT INCLUDE HEAD GASKETS

 <p>18-64217 POWERHEAD GASKET SET Replaces: 27-815791A00 Fits: Mercury 150/175 EFI(G960500-T408999)</p>	 <p>18-64221 POWERHEAD GASKET SET Replaces: 3V1-87121-0 Fits: F8/F9.8</p>	 <p>18-2736 HEAD GASKET Replaces: 27-863895, 27-863891, 27-863893 For: 15-25HP 2 cyl</p>	
 <p>18-3804 HEAD GASKET Replaces: 27-19138M, 19138, 27-84733M For: Model 30A; S/N Code 689</p>	 <p>18-3828 HEAD GASKET Replaces: 27-18937M, 27-18937, 27-98990M, 27-83899M For: Model 9.9C; S/N Code 682 & Model 15C, S/N Code 684</p>	 <p>18-3861 HEAD GASKET Replaces: 27-187851, 27-187853, 27-18785T For: Model 135, 150 and XR4</p>	
 <p>18-3862 HEAD GASKET Replaces: 27-41246-1 For: Model 175, 200, XR4</p>	 <p>18-3844 HEAD GASKET Replaces: 27-803508 For: 4-Stroke O/B's, 4/5/6 HP S/N OR000001 & Up</p>	 <p>18-3871 HEAD GASKET Replaces: 27-18786-1 For: Model 175, XR4, Mag II</p>	
 <p>18-3863 HEAD GASKET Replaces: 27-96542-1 For: Model 150</p>	 <p>18-3864 HEAD GASKET Replaces: 27-822844-1 For: Model 175, 200 and XR6</p>	 <p>18-3872 HEAD GASKET Replaces: 27-41245-1 For: 200 and 225 HP</p>	
 <p>18-3845 HEAD GASKET Replaces: 27-825032 For: 4-Stroke O/B's, 40/45/50 HP S/N OG760300 & Up</p>	 <p>18-3827 HEAD GASKET Replaces: 27-8254821, 27-825482 For: 8, 9.9 HP 4-Stroke</p>	 <p>18-60916 CYLINDER HEAD GASKET Replaces: 27-850836001 Fits: Mercury 8/9.9 (R042475 & Up)</p>	<p>PKG. OF 5</p>  <p>18-7400 18-7400-9^① O-RING HEAD GASKET Replaces: 25-818573 1 per cylinder, 3 per cylinder head</p>
<p style="text-align: center;">① Priced per Package GASKET SET APPLICATION ON NEXT PAGE *POWERHEAD GASKET SETS DO NOT INCLUDE HEAD GASKETS</p>			

HEAD GASKET/GASKET SET APPLICATION









Model	Cyl.	Beg. S/N	End S/N	Gasket Set	Head O-Rings	Head Gasket	Head Seals
4/5/6 (4 stroke)	1 CYL	R000001	& UP	—	—	18-3844	—
8 FOUR STROKE (232cc)		H000058	H017349	—	—	18-3827	—
8 FOUR STROKE (232cc)		G760300	T178499	—	—	18-3827	—
9.9 FOUR STROKE (232cc)		H000058	H017349	—	—	18-3827	—
18 (18XD)	2	6416713	6443972	18-4334	—	—	—
20 (20,20XD, 200)	2	6443973	OT800999	18-4334	—	—	—
20 JET	2	G044027	& UP	18-4334	—	—	—
30 JET (40 HP)	4 CYL	C159200	& UP	18-4325	—	—	—
35	2 CYL	6445653	B110788	18-4355	—	—	—
40,402	2 CYL	3336258	G053313	18-4355	—	—	—
40	4 CYL	C159200	& UP	18-4325	—	—	—
40 FOUR STROKE (232cc)	3 CYL	G231123	T178499	—	—	18-3845	—
45	4 CYL	5531630	0B110788	18-4353	—	—	—
45	4 CYL	B110789	& UP	18-4325	—	—	—
45 Jet	3 CYL	D000750	& UP	18-4337	—	—	—
45 FOUR STROKE (BODENSEE)		G231123	T178499	—	—	18-3845	—
50,500	4 CYL	2116318	& UP	18-4353	—	—	—
50, 60	4 CYL	6428681	B122929	18-4357	—	—	—
50	3 CYL	D000750	OG589999	18-4337	—	—	—
50	3 CYL	B122930	D000749	18-4326	—	—	—
50 FOUR STROKE		G231123	T178499	—	—	18-3845	—
55	3 CYL	6428681	B122929	18-4357	—	—	—
55	3 CYL	D000750	& UP	18-4337	—	—	—
65 (650)	3 CYL	3293184	4382056	—	—	—	—
65 (650)	3 CYL	4382057	4571651	18-4357	—	—	—
70	3 CYL	4571652	A996141	18-4357	—	—	—
70	3 CYL	A996142	& UP	18-4336	—	—	—
75	4 CYL	6432901	& UP	18-4354	—	—	—
80	3 CYL	A996142	& UP	18-4336	—	—	—
80 Jet	4 CYL	D283222	& UP	18-4340	—	—	—
80,800	4 CYL	2559001	3493912	18-4350	—	—	—
80,800	4 CYL	4831999	6432900	18-4354	—	—	—
85,850	4 CYL	3493913	4366801	18-4351	—	—	—
85,850	4 CYL	4366802	4831998	18-4354	—	—	—
90,900	6 CYL	4845301	& UP	18-4356	—	—	—
90	3 CYL	A996142	& UP	18-4336	—	—	—
100	4 CYL	B209468	& UP	18-4340	—	—	—
105 JET	6 CYL	D082000	& UP	18-4359	—	18-3864 ^②	—1
115	4 CYL	C100000	& UP	18-4340	—	—	—
125	4 CYL	D283222	& UP	18-4340	—	—	—
140 (140, 1400)	6 CYL	3293234	3502805	18-4356	—	—	—
140 (140, 1450)	6 CYL	4865678	& UP	18-4356	—	—	—
140 (140, 1400)	6 CYL	4865678	& UP	18-4356	—	—	—
150 (1500)	6 CYL	3502806	5327622	18-4356	—	—	—
V-135	V-6	A904646	C239552	18-4317 ^①	—	18-3863	—
V-135	V-6	C239553	G960499	18-4359	—	18-3861	—1
V-135 DFI	V-6	G590000	G960499	18-4338	—	—	—1
140 JET	V-6	D082000	G960499	18-4359	—	18-3864	—1
V-150 (150, 1500)	V-6	4868998	6042945	18-4315	—	—	—
V-150	V-6	6042946	C239552	18-4317 ^①	—	18-3863	—
V-150	V-6	C239553	G960499	18-4359	—	18-3861	—1
V-150	V-6	G960500	& UP	18-4338	—	—	—6
V-150 (XR/MAGNUM II)	V-6	B242885	C239552	18-4319 ^①	—	—	—
V-150 XR4	V-6	C239553	D081999	18-4359	—	18-3871	—1
V-150 (XR6/MAGNUM III)	V-6	D082000	G960499	18-4359	—	18-3864 ^{②④}	—1
V-150 (EFI)		D082000	G960499	18-4359	N/A	—	—1

^① Gasket set includes head gasket ^④ Used on a 2.5L with a 3.5" bore **2** Cyl head o-rings & seal not included in gskt kit
^② 2 head gaskets required ^⑤ Requires 3 per cylinder head **3** Cyl head o-rings not included in gskt kit **6** Cyl head gaskets & seal not included in gskt set
^③ Used on a 2.4L with a 3.38" bore **1** head gaskets not included in gskt set

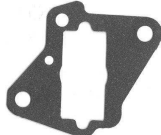
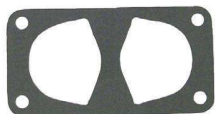
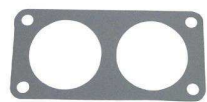
HEAD GASKET/GASKET SET APPLICATION



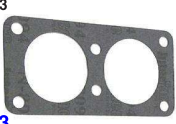













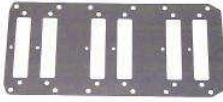



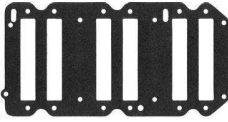
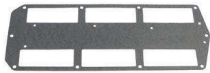

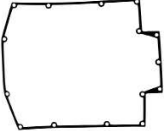
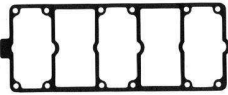

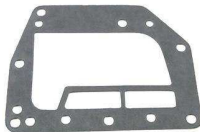

Model	Cyl.	Beg. S/N	End S/N	Gasket Set	Head O-Rings	Head Gasket	Head Seals
150 MAR	V-6	5600162	6038680	18-4315	—	—	—
150 MAR	V-6	6038681	C239553	18-4317 ①	—	18-3863 ②	—
150 MAR	V-6	C239554	& UP	18-4359	—	18-3861 ②	—
V-175 (175, 1750)	V-6	4301235	6618750	18-4315	—	—	—
V-175	V-6	6618751	C239552	18-4319 ①	—	18-3862	—
V-175	V-6	C239553	D081999	18-4359	—	18-3871 ②③	— 1
V-175	V-6	D082000	G960499	18-4359	—	18-3864 ③④	—
V-175 (EFI)	V-6	D000750	D081999	18-4359	—	18-3871 ②③	— 1
V-175 XRI EFI	V-6	D000750	D081999	18-4359	—	18-3864 ②④	—
V-175 (EFI)	V-6	D082000	G303045	18-4359	—	18-3864 ②④	— 1
V-200 (200,2000)	V-6	4839034	6073191	—	—	18-3872 ②	—
V-200	V-6	6073192	6203990	—	—	18-3872 ②	—
V-200	V-6	6203991	C291519	18-4319 ①	—	18-3862 ②③	—
V-200	V-6	C291520	D081999	18-4359	—	18-3864 ②④	— 1
V-200	V-6	D082000	G960499	18-4359	—	—	— 1
V-200 (EFI)	V-6	C100861	OC291519	18-4339	—	18-3862	—
V-200 (EFI)	V-6	C291520	G960499	18-4359	—	18-3864	— 1
V-200 (DFI) 3.0L	V-6	G386496	G589999	—	18-7400	—	—
V-200 (DFI) 3.0L	V-6	G590000	G960499	18-4335	18-7400	—	— 2
V-200 (DFI) 3.0L	V-6	G960500	T178499	—	18-7400	—	— 3
V-200 XRI EFI	V-6	C100861	C291519	—	—	18-3862 ②	—
V-200 XRI EFI	V-6	C291520	& UP	18-4359	—	18-3864 ②④	—
V-220	V-6	B117316	& UP	18-4339	—	18-3862 ②	—
V-225 SEA PRO	V-6	G245605	OT408999	—	18-7400 ⑤	—	—
V-225 (EFI) 3.0L	V-6	G129222	T408999	—	18-7400 ⑤	—	—
V-225 DFI (3.0L)	V-6	G590000	OG960499	18-4335	18-7400 ⑤	—	— 3
V-225 DFI (3.0L)	V-6	G960500	T178499	—	18-7400 ⑤	—	— 3
V-250 (EFI) 3.0L	V-6	G129222	T408999	—	18-7400 ⑤	—	—

- ① Gasket set includes head gasket ④ Used on a 2.5L with a 3.5" bore ② Cyl head o-rings & seal not included in gskt kit
- ② 2 head gaskets required ⑤ Requires 3 per cylinder head ③ Cyl head o-rings not included in gskt kit ⑥ Cyl head gaskets & seal not included in gskt set
- ③ Used on a 2.4L with a 3.38" bore ① head gaskets not included in gskt set

 18-0101 CARB TO SILENCER BOX GASKET Replaces: 27-76952, 27-73397 4 Cyl.	 18-0324 CARB TO MANIFOLD GASKET Replaces: 27-15172 3, 27-151724, 27-15172, 27-93214	 18-0384 CARB GASKET Replaces: 27-892211, 27-817533, 27-89221, 27-8M0027781 200/225 HP	 18-0633 CARB MOUNTING GASKET Replaces: 27-192061, 27-42178, 27-19206, 27-414491, 27-41449	
 18-0641 CARB MOUNTING GASKET Replaces: 27-828292	PKG. OF 3  18-2509 18-2509-9 ⑥ CARB MOUNTING GASKET Replaces: 27-67751 V-6	PKG. OF 2  18-2571 18-2571-9 ⑥ CARB FLANGE GASKET Replaces: 27-31402	PKG. OF 2  18-2572 18-2572-9 ⑥ CARB FLANGE GASKET Replaces: 27-63309, 27-22023	
PKG. OF 2  18-2800 18-2800-9 ⑥ CARB MOUNTING GASKET Replaces: 27-757911, 27-75791, 27-69659, 27-26891 20-45-50 HP	PKG. OF 2  18-2802 18-2802-9 ⑥ CARB FLANGE GASKET Replaces: 27-48164, 27-481641	PKG. OF 3  18-2803 18-2803-9 ⑥ CARB MOUNTING GASKET Replaces: 27-90430, 27-904301 V-6	PKG. OF 4  18-2804 18-2804-9 ⑥ CARB MOUNTING GASKET Replaces: 27-733771, 27-73377 3-4 Cyl.	PKG. OF 2  18-2568 18-2568-9 ① STRAINER COVER SCREW GASKET Replaces: 27-25848

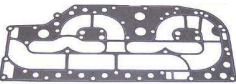
SEE PAGES 201-202 FOR OUR COMPLETE LINE OF GASKET SEALANTS













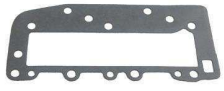

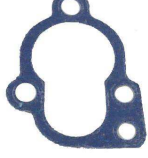





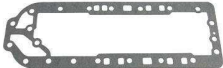



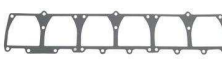

⑥ Priced per Package

 <p>18-2569 18-2569-9① FILTER COVER GASKET Replaces: 27-25849</p>	 <p>18-2570 18-2570-9① STRAINER COVER GASKET Replaces: 27-25851, 27-34614</p>	 <p>18-2575 18-2575-9① CARB BOWL GASKET Replaces: 1399-99</p>	 <p>18-0970 18-0970-9① FUEL PUMP GASKET Replaces: 27-987691, 27-98769</p>	 <p>18-0740-1 THROTTLE BODY GASKET Replaces: 27-805396</p>												
 <p>18-0359 INDUCTION SILENCER COVER GASKET Replaces: 27-672751, 27-67275</p>	 <p>18-2737 REED BLOCK GASKET Replaces: 27-850283 For: 200 DFI, 225 DFI</p>	 <p>18-0129 REED BLOCK GASKET Replaces: 27-657443, 27-657442, 27-657441, 27-65744 V-6</p>	 <p>18-0320 REED BLOCK GASKET Replaces: 27-13937-6</p>	 <p>18-0644 REED PLATE GASKET Replaces: 27-146972</p>												
 <p>18-0646 REED PLATE GASKET Replaces: 27-813859</p>	 <p>18-2501 18-2501-9① REED BLOCK HOUSING GASKET Replaces: 27-935361, 27-93536, 27-67738 V-6</p>	 <p>18-2510 18-2510-9① REED BLOCK HOUSING GASKET Replaces: 27-967611, 27-96761 V-200</p>	 <p>18-0624 ATTENUATOR GASKET Replaces: 27-188891</p>													
<p>PKG. OF 5 CRANKCASE GASKETS</p> <table border="1"> <thead> <tr> <th>Part #</th> <th>Replaces:</th> <th>Description</th> </tr> </thead> <tbody> <tr> <td>18-2512 ②</td> <td>27-60286</td> <td>Crankcase to Cyl. Block 3 Cyl.</td> </tr> <tr> <td>18-2513 ②</td> <td>27-11338, 27-67208</td> <td>Cyl. Block Sealing V-6</td> </tr> <tr> <td>18-2514 ②</td> <td>27-53650</td> <td>Crankcase to Cyl. Block 4 Cyl.</td> </tr> </tbody> </table>					Part #	Replaces:	Description	18-2512 ②	27-60286	Crankcase to Cyl. Block 3 Cyl.	18-2513 ②	27-11338, 27-67208	Cyl. Block Sealing V-6	18-2514 ②	27-53650	Crankcase to Cyl. Block 4 Cyl.
Part #	Replaces:	Description														
18-2512 ②	27-60286	Crankcase to Cyl. Block 3 Cyl.														
18-2513 ②	27-11338, 27-67208	Cyl. Block Sealing V-6														
18-2514 ②	27-53650	Crankcase to Cyl. Block 4 Cyl.														
 <p>18-0645 ADAPTER PLATE GASKET Replaces: 27-167371</p>	 <p>18-0105 BAFFLE GASKET Replaces: 27-85489-2</p>	 <p>18-0107 EXHAUST COVER GASKET Replaces: 27-85498-1, 27-85498, 27-64203, 27-72510 4 Cyl.</p>	 <p>18-0131 BAFFLE GASKET Replaces: 27-695252, 27-695251, 27-69525, 27-64857 3 Cyl.</p>	 <p>18-0133 WATER JACKET GASKET Replaces: 27-73665, 27-52892 4 Cyl.</p>												
 <p>18-0137 BAFFLE GASKET Replaces: 27-85492-2 50 HP</p>	 <p>18-0371 BAFFLE GASKET Replaces: 27-78409, 27-39316, 27-72915 20 HP</p>	 <p>18-0373 BAFFLE GASKET Replaces: 27-78411, 27-45088, 27-72917 20 HP</p>	 <p>18-0918 PLATE TO EXHAUST MANIFOLD GASKET Replaces: 27-695242, 27-695241, 27-69524 3 Cyl.</p>	 <p>18-2712 ADAPTER PLATE GASKET Replaces: 27-414181, 27-41418, 27-85979 For: 15-25 2 cyl</p>												
 <p>18-2621 BAFFLE GASKET Replaces: 27-139581 For: 100HP 4 cyl, 115HP 4 cyl</p>	 <p>18-2710 REED BLOCK GASKET Replaces: 27-414172, 27-414171, 27-41417, 27-85978 For: 15-25HP 2 cyl</p>	 <p>18-0380 THERMOSTAT GASKET Replaces: 27-83940M</p>	 <p>18-2721 THERMOSTAT GASKET Replaces: 27-827284 For: 30-60HP 3 cyl outboards</p>	 <p>18-2729 THERMOSTAT GASKET Replaces: 27-8128672 For: 30-40HP 2 cyl, 45 Jet, 50-60 3 cyl</p>												

SEE PAGES 201-202 FOR OUR COMPLETE LINE OF GASKET SEALANTS















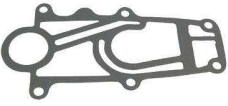

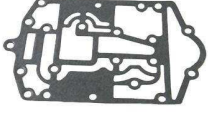



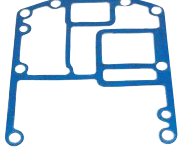

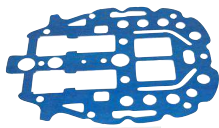

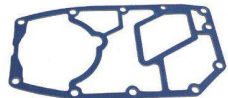

① Priced per Package

② This product is priced per piece. To order priced per package, please add -9 to the part number

 <p>18-2749 THERMOSTAT GASKET Replaces: 27-8128671, 27-812867 For: 45 Jet, 50-60 HP 3 cyl</p>	 <p>18-3675 THERMOSTAT GASKET Replaces: 27-850318, 27-8503181 For: 200-250HP 3.0L, (DFI and EFI)</p>	 <p>PKG. OF 2 18-0922 18-0922-9① BAFFLE GASKET Replaces: 27-703351, 27-70335 3 Cyl.</p>	 <p>18-0940 BAFFLE GASKET Replaces: 27-854882, 27-854881, 27-85488, 27-78027, 27-55308</p>	 <p>18-0942 BAFFLE GASKET Replaces: 27-85491-2, 27-854913, 27-854911, 27-85491, 27-72486, 27-46110 45/50 HP</p>
 <p>18-0944 BAFFLE GASKET Replaces: 27-854961, 27-85496, 27-64204, 27-72508</p>	 <p>18-0232 COVER GASKET Replaces: 27-81031M</p>	 <p>PKG. OF 2 18-2573 18-2573-9① WATER JACKET GASKET Replaces: 27-721421, 27-72142, 27-60475 6 Cyl.</p>	 <p>PKG. OF 2 18-2574 18-2574-9① EXHAUST COVER GASKET Replaces: 27-854952, 27-854951, 27-85495, 27-72507, 27-60476 6 Cyl.</p>	 <p>PKG. OF 2 18-2836 18-2836-9① BAFFLE GASKET Replaces: 27-78035, 27-72919, 27-46233, 27-31439 7.5-10 HP</p>
 <p>PKG. OF 2 18-2839 18-2839-9① EXHAUST COVER GASKET Replaces: 27-854972, 27-854971, 27-85497, 27-72509, 27-60477</p>	 <p>18-0151 DIVIDER PLATE GASKET Replaces: 27-76636, 27-75952 V-6</p>	 <p>18-0642 DIVIDER PLATE GASKET Replaces: 27-190503, 27-19050, 27-190502, 27-190505</p>	 <p>PKG. OF 2 18-2502 18-2502-9① DIVIDER PLATE GASKET Replaces: 27-904841, 27-90484, 27-87396 V-6</p>	 <p>18-0870 TRANSFER PORT COVER GASKET Replaces: 27-279361, 27-27936</p>
 <p>18-0926 TRANSFER PORT COVER GASKET Replaces: 27-73645</p>	 <p>18-0932 TRANSFER PASSAGE COVER GASKET Replaces: 27-768621, 27-76862 3 Cyl.</p>	 <p>18-0946 TRANSFER PORT GASKET Replaces: 27-85653-1, 27-856730, 27-85653 6 Cyl.</p>	 <p>PKG. OF 3 18-2838 18-2838-9① TRANSFER PORT COVER GASKET Replaces: 27-552791, 27-55279</p>	 <p>18-0372 CYLINDER BLOCK GASKET Replaces: 27-78410, 27-52579, 27-72916 20 HP</p>
 <p>18-2740 CYLINDER BLOCK GASKET Replaces: 27-430057, 27-430056, 27-430055, 27-430053, 27-430052, 27-430051 For: 65 Jet, 75HP 3 cyl, 90HP 3 cyl</p>	 <p>18-2943 CYLINDER BLOCK GASKET Replaces: 27-443281, 27-443282, 27-443283, 27-443284 For: 80 Jet, 100HP, 115HP, and 125HP 4 cyl outboards</p>	 <p>PKG. OF 2 18-2500 18-2500-9① EXHAUST COVER GASKET Replaces: 27-85493, 27-72505, 27-52893 80 HP</p>	 <p>PKG. OF 2 18-2505 18-2505-9① CYLINDER BLOCK GASKET Replaces: 27-961711, 27-96171 75-80 HP</p>	 <p>PKG. OF 2 18-2507 18-2507-9① CYLINDER BLOCK GASKET Replaces: 27-85487, 27-78026, 27-72487, 27-37816 40-50 HP</p>
 <p>PKG. OF 2 18-2805 18-2805-9① BLOCK COVER GASKET Replaces: 27-85490-2 35-40 HP</p>	 <p>PKG. OF 2 18-2504 18-2504-9① BLOCK COVER GASKET Replaces: 27-88449, 27-76401, 27-74511, 27-60310 3 Cyl.</p>	 <p>PKG. OF 2 18-2806 18-2806-9① CYLINDER COVER GASKET Replaces: 27-65788 V-6</p>	 <p>PKG. OF 2 18-2807 18-2807-9① BLOCK COVER GASKET Replaces: 27-981853, 27-9818512, 27-981851, 27-98185, 27-85494, 27-72506, 27-64940, 27-53863 90-115 HP</p>	 <p>PKG. OF 2 18-2808 18-2808-9① CYLINDER COVER GASKET Replaces: 27-96278 V-6</p>

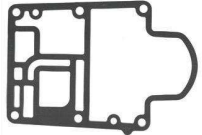

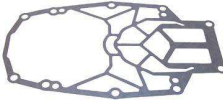









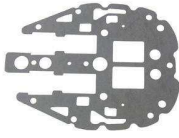
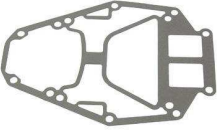
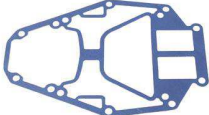







SEE PAGES 201-202 FOR OUR COMPLETE LINE OF GASKET SEALANTS

① Priced per Package

 <p>18-60917 CYLINDER COVER GASKET Replaces: 27-803508017 Fits: Mercury 8/9.9 (R042475 & Up)</p>	 <p>PKG. OF 2 18-2810 18-2810-9^① BLOCK COVER GASKET Replaces: 27-437772, 27-437771, 27-43777, 27-96483 45-50 HP</p>	 <p>PKG. OF 2 18-2837 18-2837-9^① BLOCK COVER GASKET Replaces: 27-41382, 27-78087, 27-72918, 27-66358, 27-31436</p>	 <p>18-0333 POWERHEAD BASE GASKET Replaces: 27-39401</p>	 <p>18-0334 MOUNTING PLATE TO DRIVESHAFT HOUSING GASKET Replaces: 27-39402</p>
 <p>18-0336 ADAPTER PLATE GASKET Replaces: 27-41670-3, 27-41670-5 18 HP</p>	 <p>18-0649 SHIFT ROD HOUSING GASKET Replaces: 27-858935 For: 200 HP T801000 & UP, 200 HP OPTIMAX DFI G438000 & UP, 225 HP EFI G438000 & UP, 225 HP OPTIMAX DFI G590000-G960499, 250 HP EFI G438000 & UP, (MODELS WITH "C-3 CASTING": 200 HP OPTIMAX DFI G386496-G437999, 225 HP D280813-G437999, 225 HP EFI G129222-G437999, 250 HP EFI G129222-G437999)</p>	 <p>18-0341 EXHAUST PLATE GASKET Replaces: 27-430086, 27-43008, 27-430082, 27-430083, 27-430085 For: 70-90, 100, 115 & 125 HP</p>	 <p>18-0791 SHIFT SHAFT COVER GASKET Replaces: 27-880729 For: All Verado's 135/150/175/200 225/250/275</p>	
 <p>18-0369 POWERHEAD BASE GASKET Replaces: 27-75909 V-6</p>	 <p>18-0378 POWERHEAD BASE GASKET Replaces: 27-823142, 27-823142 2</p>	 <p>18-0670 POWERHEAD BASE GASKET Replaces: 27-430075, 27-430073, 27-43007</p>	 <p>18-0385 POWERHEAD BASE GASKET Replaces: 27-89937, 27-31557, 27-30803, 27-45748 4.5-9.8 HP</p>	 <p>18-0643 POWERHEAD BASE GASKET Replaces: 27-18307-1, 27-183076</p>
 <p>18-0879 ADAPTER PLATE GASKET Replaces: 27-385011, 27-38501, 27-37724</p>	 <p>18-0904 POWERHEAD BASE GASKET Replaces: 27-60317 65 HP</p>	 <p>18-0135 ADAPTER COVER GASKET Replaces: 27-78246, 27-78246 1</p>	 <p>18-0103 POWERHEAD BASE GASKET Replaces: 27-796501, 27-79650, 27-37725, 27-72496</p>	 <p>18-0139 POWERHEAD BASE GASKET Replaces: 27-884511, 27-88451, 27-78623, 27-76589</p>
 <p>18-2735 DIVIDER PLATE GASKET Replaces: 27-190506 For: 140 Jet, 115-200HP (2.5L), XR-6</p>	 <p>18-2713 DRIVESHAFT HOUSING GASKET Replaces: 27-433374, 27-43337, 27-43337A1, 27-433371, 27-433372, 27-433373, 27-96286 For: 15-25 2 cyl</p>	 <p>18-2714 EXHAUST COVER GASKET Replaces: 27-414995, 27-414994, 27-414993, 27-414992, 27-892157 For: 15-25 HP, 2 Cyl.</p>	 <p>18-2716 EXHAUST COVER GASKET Replaces: 27-414991, 27-41499, 27-92332 For: 18XD, 20XD (2 cyl), 25XD</p>	 <p>18-2741 EXHAUST COVER PLATE GASKET Replaces: 27-430047, 27-430045, 27-430043, 27-430042, 27-430041, 27-43004009 For: 65 Jet, 75HP 3 cyl, 90HP 3 cyl</p>
 <p>18-2717 EXHAUST MANIFOLD GASKET Replaces: 27-414758, 27-414757, 27-414756, 27-414755, 27-414754, 27-414753, 27-414752, 27-414751, 27-41475, 27-92331, 27-892158 For: 15-25HP 2 cyl</p>	 <p>18-0319 POWERHEAD BASE GASKET Replaces: 27-828553 For: 30-60HP 2 cyl and 3 cyl</p>	 <p>18-2610 OUTER EXHAUST PLATE GASKET Replaces: 27-8127754, 27-812755 For: 80 Jet, 100HP, 115HP, and 125HP 4 cyl outboards</p>	 <p>18-2739 EXHAUST PLATE GASKET Replaces: 27-8329335, 27-8329334, 27-8329333, 27-8329332, 27-8329331, 27-832933006 For: 250XS (3.0L) DFI</p>	 <p>18-2611 INNER EXHAUST PLATE GASKET Replaces: 27-8127551, 27-8127755, 27-812755A01 For: 80 Jet, 100HP, 115HP, and 125HP 4 cyl outboards</p>



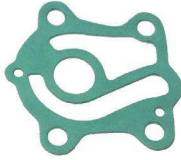



SEE PAGES 201-202 FOR OUR COMPLETE LINE OF GASKET SEALANTS

① Priced per Package

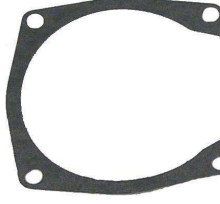
 <p>18-0912 DRIVE SHAFT HOUSING PLATE GASKET Replaces: 27-661021, 27-66102, 27-60945</p>	 <p>18-0934-1 POWERHEAD BASE GASKET Replaces: 27-78069</p>	 <p>18-0988 POWERHEAD BASE GASKET Replaces: 27-628601, 27-62860, 27-37976</p>	<p>PKG. OF 2</p>  <p>18-2503 18-2503-9① DRIVE SHAFT HOUSING TO EXHAUST PLATE GASKET Replaces: 27-991771, 27-991772, 27-99177, 27- 78068 V-6</p>	<p>PKG. OF 2</p>  <p>18-2506-1 18-2506-1-9① EXHAUST PLATE GASKET Replaces: 27-991763, 27-991764, 27-991762, 27-99176 V-175/V-200</p>
<p>PKG. OF 2</p>  <p>18-2508-1 18-2508-1-9① EXHAUST PLATE GASKET Replaces: 27-997761, 27-99776, 27-96440 V-135/V-150</p>	<p>PKG. OF 2</p>  <p>18-2809 18-2809-9① BLOCK COVER GASKET Replaces: 27-437792, 27-437791, 27-43779, 27-96485 50-60-HP</p>	<p>PKG. OF 2</p>  <p>18-2511 18-2511-9① DRIVE SHAFT HOUSING TO EXHAUST PLATE GASKET Replaces: 27-99173-2 V-6</p>	 <p>18-60919 EXHAUST COVER GASKET Replaces: 27-834952001 Fits: Mercury 8/9.9 (R042475 & Up)</p>	<p>PKG. OF 2</p>  <p>18-2835 18-2835-9① POWERHEAD BASE GASKET Replaces: 27-692381, 27-69238, 27-66101, 27-64173, 27-60479 75-90-115-140 Hp</p>
 <p>18-0982-1 POWERHEAD GASKET Replaces: 27-56304, 27-48713</p>	 <p>18-60918 ENGINE BASE GASKET Replaces: 27-835427003 Fits: Mercury 8/9.9 (R042475 & Up)</p>	<p>PKG. OF 2</p>  <p>18-0182 18-0182-9① THERMOSTAT GASKET Replaces: 27-62386</p>	 <p>18-0323 THERMOSTAT GASKET Replaces: 27-14318-2, 27-14318 3</p>	 <p>18-0339 THERMOSTAT GASKET Replaces: 27-43006-2, 27-430066 70-90 HP</p>
 <p>18-0835 THERMOSTAT GASKET Replaces: 27-824853, 27-8248531 Fits: Mercury 9.9-60 H.P., 4-Stroke</p>	<p>PKG. OF 2</p>  <p>18-0914 THERMOSTAT GASKET Replaces: 27-66847</p>	 <p>18-60920 THERMOSTAT GASKET Replaces: 27-853702005 Fits: Mercury 8/9.9 (R042475 & Up)</p>	<p>PKG. OF 2</p>  <p>18-0936 18-0936-9① RELIEF VALVE PLATE GASKET Replaces: 27-78690 V-6</p>	<p>PKG. OF 2</p>  <p>18-0952 18-0952-9① RELIEF VALVE PLATE GASKET Replaces: 27-88907 V-6</p>
<p>PKG. OF 2</p>  <p>18-2558 18-2558-9① IMPELLER GASKET Replaces: 27-19204-2 6/8/9.9/15</p>	 <p>18-0292 WEAR PLATE TO PUMP HOUSING GASKET Replaces: 27-81417M</p>	<p>PKG. OF 2</p>  <p>18-0294 18-0294-9① WEAR PLATE TO PUMP BASE GASKET Replaces: 27-81421M</p>	<p>PKG. OF 2</p>  <p>18-2559 18-2559-9① IMPELLER GASKET Replaces: 27-42206, 27-19202 6/8/9.9/15</p>	<p>PKG. OF 2</p>  <p>18-2561 18-2561-9① IMPELLER GASKET Replaces: 27-85087 18/25 S/N 6443972 & Below</p>

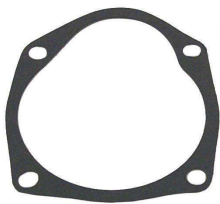

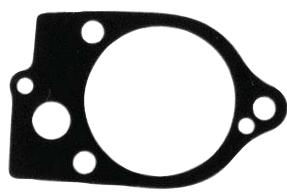
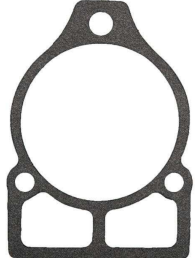
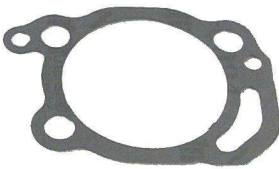

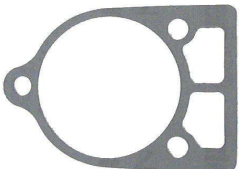





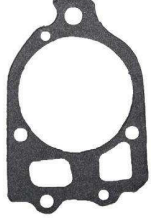
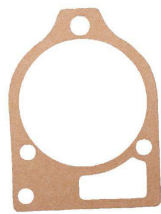









SEE PAGES 201-202 FOR OUR COMPLETE LINE OF GASKET SEALANTS

① Priced per Package

<p>PKG. OF 2</p>  <p>18-2564 18-2564-9^① IMPELLER GASKET 70/75/80/90/100/115 Replaces: 27-430331, 27-43033</p>	<p>PKG. OF 2</p>  <p>18-2565 18-2565-9^① IMPELLER GASKET 70/75/80/90/100/115 Replaces: 27-430472, 27-430471, 27-43047</p>	<p>PKG. OF 2</p>  <p>18-2566 18-2566-9^① IMPELLER GASKET 75/90/100/115 Replaces: 27-817277, 27-8172771</p>	<p>PKG. OF 2</p>  <p>18-2562 18-2562-9^① IMPELLER GASKET 18/20/25 S/N 6443973 & Above Replaces: 27-993261, 27-99326</p>
<p>PKG. OF 2</p>  <p>18-2563 18-2563-9^① IMPELLER GASKET 70/75/80/90/100/115 Replaces: 27-430341, 27-43034</p>	<p>PKG. OF 2</p>  <p>18-2801 18-2801-9^① WATER PUMP GASKET Replaces: 27-32438 4-6 Cyl.</p>	<p>PKG. OF 2</p>  <p>18-2823 18-2823-9^① LOWER, WATER PUMP GASKET Replaces: 27-32769, 27-19553 40-50-70 HP</p>	<p>PKG. OF 2</p>  <p>18-2824 18-2824-9^① UPPER, WATER PUMP GASKET Replaces: 27-32770, 27-19551</p>
<p>PKG. OF 2</p>  <p>18-2825 18-2825-9^① WATER PUMP BASE GASKET Replaces: 27-32771 40-50-70</p>	<p>PKG. OF 2</p>  <p>18-2826 18-2826-9^① WATER PUMP BASE GASKET Replaces: 27-85610 1, 27-85670 4</p>	<p>PKG. OF 2</p>  <p>18-2827 18-2827-9^① UPPER FACE PLATE GASKET Replaces: 27-39623 20 HP</p>	<p>PKG. OF 2</p>  <p>18-2828 18-2828-9^① LOWER WATER PUMP GASKET Replaces: 27-39625 20 HP</p>
<p>18-0622 LOWER WEAR PLATE GASKET Replaces: 27-19701</p> 	<p>18-2593 WATER PUMP GASKET Replaces: 27-194541 For: 45 Jet, 50HP, 55HP, 60HP 3 cyl outboards</p> 	<p>18-0345 WATER PUMP GASKET Replaces: 27-822189 For: 25-60HP outboards, 2, 3 cyl. & 4 stroke models</p> 	<p>PKG. OF 2</p> <p>18-2841 18-2841-9^① WATER PUMP BASE GASKET Replaces: 27-77417, 27-19552</p> 

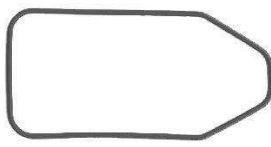
SEE PAGES 201-202 FOR OUR COMPLETE LINE OF GASKET SEALANTS

^① Priced per Package

<p>PKG. OF 2</p>  <p>18-2914 18-2914-9^① WATER PUMP GASKET Replaces: 27-856081, 27-85608, 27-32433, 27-30603, 27-8M0090319</p>	<p>PKG. OF 2</p>  <p>18-2915 18-2915-9^① WATER PUMP GASKET Replaces: 27-856091, 27-858524, 27-85609, 27-32434, 27-30604</p>	<p>PKG. OF 2</p>  <p>18-2919 18-2919-9^① WATER PUMP GASKET Replaces: 27-426311, 27-42631</p>	<p>PKG. OF 2</p>  <p>18-0514 WATER TUBE RUBBER SEAL Replaces: 26-25329</p>
 <p>18-0521 WATER TUBE RUBBER SEAL Replaces: 26-36557</p>	 <p>18-0563 WATER TUBE RUBBER SEAL Replaces: 26-36556</p>	 <p>18-0539 EXHAUST LEG RUBBER SEAL Replaces: 37721</p>	 <p>18-2728 WATER TUBE SEAL Replaces: 26-42102, 26-421021</p>
<p>PKG. OF 2</p>  <p>18-2560 18-2560-9^① IMPELLER GASKET Replaces: 12-86645, 12-866451, 8M0027721 18/20/25</p>	<p>PKG. OF 5</p>  <p>18-2430 18-2430-9^① 18-24301-9^① (PKG. OF 50) DRAIN SCREW GASKET Replaces: 26-830749 For: All Verado</p>	<p>PKG. OF 2</p>  <p>18-2945 18-2945-9^① DRAIN SCREW GASKET Replaces: 12-20260, 12-19183, 12-191832, 191833, F50556, F8077, F8186 Used in most lower units and sea water pumps</p>	<p>PKG. OF 2</p>  <p>18-2948 18-2948-9^① RUBBER WASHER Replaces: 12-492211, 12-49221, 12-23245 For plastic flush screw and fuel tank vent</p>
 <p>18-4261 WASHER Replaces: 19643</p>	<p>PKG. OF 4</p>  <p>18-0568-9^③ INSULATOR BUSHING Replaces: 23-43045</p>	 <p>18-8305 DIVIDER PLATE SEAL Replaces: 26-814754, 428381, 42838, 69668, 88726</p>	 <p>18-4698 18-46981-9^① (PKG. OF 50) DRAIN FILL WASHER Replaces: 27-81987, 27-81987M</p>
 <p>18-4275 WASHER Replaces: 12-29245, 12-824793, 12-38753, 12-32733, 12-25945, 12-22388</p>	<p>PKG. OF 2</p>  <p>18-4858-9^① WASHER Replaces: 12-45176 Fits: Mercury Outboard 25 H.P. and Up, Mercruiser #1, R, MR, Alpha I Gen II and Bravo Drive Units</p>	 <p>18-8309 WATER COOLED REGULATOR SEAL Replaces: 18717</p>	<p>PKG. OF 2</p>  <p>18-2730-9^① GROMMET Replaces: 26-80239M</p>
 <p>18-2731 GROMMET Replaces: 26-81607M For: 28 HP</p>	 <p>Sierra Marine Engine and Drive Parts</p>		

SEE PAGES 201-202 FOR OUR COMPLETE LINE OF GASKET SEALANTS

① Priced per Package

35 & 40 2 Cylinder

Serial # 2736807-G053313

50, 60, 65 3 Cylinder

Serial # 3293184-D000749

70 3 Cylinder

Serial # 4571652-6428680

40, 45, 50 4 Cylinder

Serial # 4357640 & later

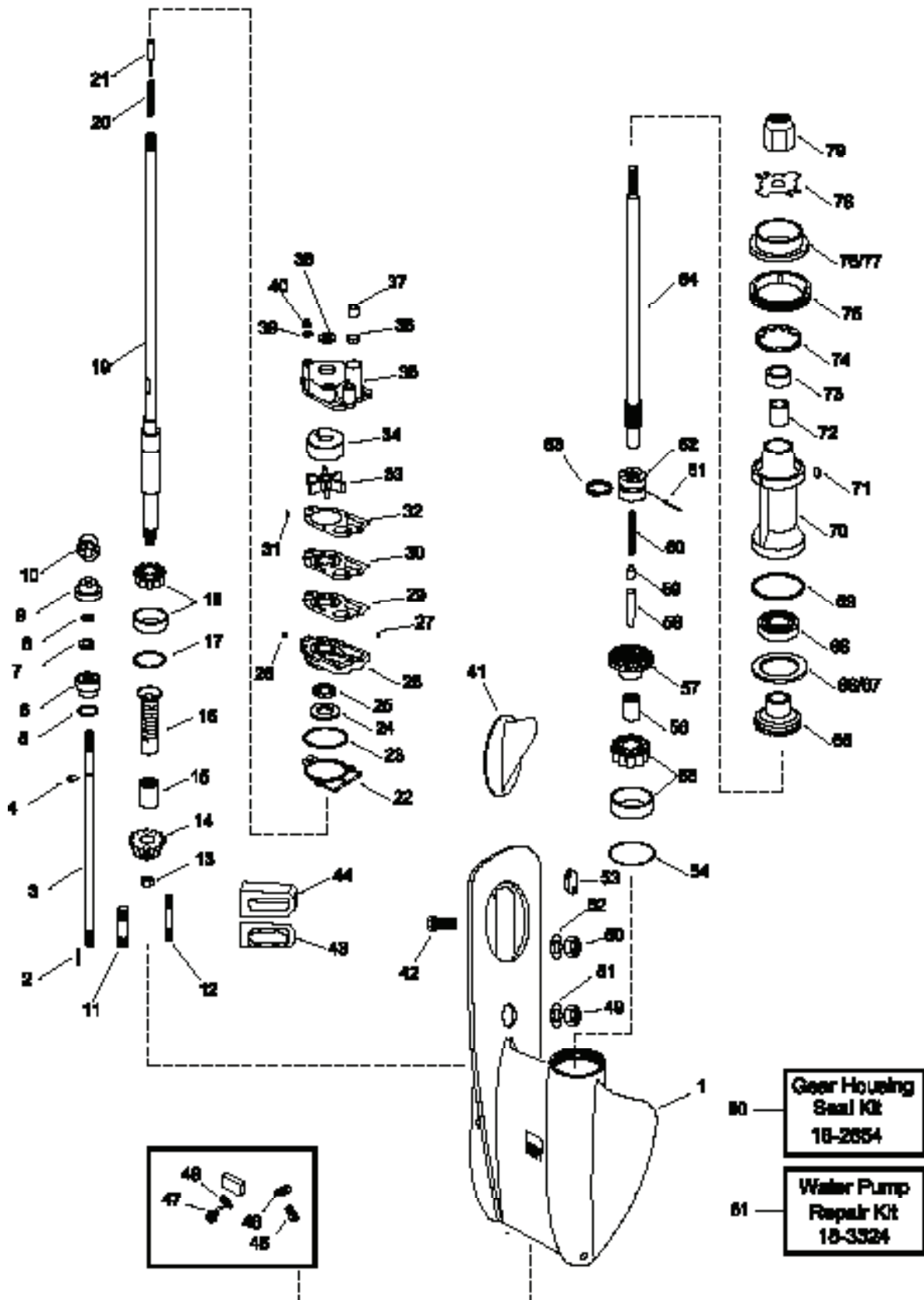

Figure #	Description	Part #	O.E.M. #	Qty.	Figure #	Description	Part #	O.E.M. #	Qty.
1	Gear Housing	—	1643-9539A1	1	48	Flush Plug Washer	18-2948	12-492211	1
2	Dowel Pin	—	17-85500	2	49	Nut	18-2361	11-34933	1
3	Shift Shaft	—	76163A1	1	50	Nut	—	1134863	1
4	E-Clip	18-4295	53-29641	1	51	Washer	—	12-65791	1
5	O-Ring	18-7153	25-25439	1	52	Washer	—	12-45175	1
6	Shift Shaft Bushing	18-2155	23-77631A2	1	53	Shift Cam	—	76039	1
7	Seal	18-2054	26-816461	1	54	Shim Set	—	15-38374A1	AR
8	Washer	18-2316	12-77674	1	55	Tapered Roller Bearing	18-1162	31-38356A1	1
9	Reverse Lock Base	—	78036	1	56	Roller Bearing	18-1096	31-21739	1
10	Reverse Lock Cam	—	433081	1	57	Forward Gear	—	43-55608A4	1
11	Stud	—	16-33778	3	58	Cam Follower	—	38441	1
12	Stud	—	16-57933	2	59	Slide	—	20843	1
13	Pinion Nut	—	11-55910	1	60	Spring	—	24-38114	1
14	Pinion Gear	—	43-98097	1	61	Cross Pin	—	17-38113	1
15	Roller Bearing	—	31-62091	1	62	Clutch	—	52-92911	1
16	Sleeve	—	88181	1	63	Spring	—	24-39845	1
17	Shim Set	—	15-92881A1	AR	64	Prop Shaft	—	44-75365	1
18	Tapered Bearing	—	31-77420A1	1	65	Reverse Gear	—	43-79158	1
19	Drive Shaft	—	45-981801	1	66	Thrust Washer	—	12-32004	1
20	Spring	—	24-20254	1	67	Shim Set	—	15-20927A1	AR
21	Pin	—	17-30545	1	68	Ball Bearing	18-1190	30-20839T	1
22	Gasket	18-2841	27-19552	1	69	O-Ring	18-7160	2531986	1
23	O-Ring	18-7115	25-26722	1	70	Bearing Carrier	—	69386A1	1
24	Seal	18-2055	26-79831	1	71	Key	—	28-30281	1
25	Seal	18-2011	26-90562	1	72	Roller Bearing	—	3121700	1
26	Water Pump Base	18-3424	46-77177A1	1	73	Seal	18-2051, 18-2052	26-69188, 26-619189	1
27 & 28	Pin, Dowel	—	17-35973	1					
29	Gasket	18-2823	27-19553	1	74	Tab Washer	—	14-53012	1
30	Face Plate	18-3107	54705	1	75	Cover Nut	—	11-87763	1
31	Key	—	28-56662	1	76	Thrust Hub	18-4233	73345A1	1
32	Gasket	18-2824	27-19551	1	77	Thrust Hub	18-3204	14-76281	1
33	Impeller	18-3007	47-89983	1	78	Tab Washer	18-3204	14-76281	1
34	Insert	18-3115	48753	1	79	Nut	18-3702	11-69578A	1
35	Water Pump body	18-3118	46-77822A1	1	80	Gear Housing Seal Kit	18-2654	26-79831A1	1
36	Nylon Washer	—	12-38453	1	81	Water Pump Repair Kit	18-3324	46-77177A3	1
37	Seal	—	26-38452	1					
38	Slinger	—	25-20273	1					
39	Washer	18-4275	12-29245	3					
40	Nut	—	11-13438	3					
41	Trim Tab	18-6011	31640A1	1					
42	Screw	—	10-66024	1					
43	Support Plate	—	92815	1					
44	Exhaust Tube Seal	18-0539	37721	1					
45	Drain Plug	18-2244	10-79953	2					
46	Washer	18-2945	12-19183	2					
47	Flush Plug	—	19-48750	1					

AR As required

70, 75, 80, 90

Serial # A996142 & later

100, 115, 125

Serial # B209468 & later

4 Cylinder

- Gear Housing
Seal Kit
18-2828**
- Water Pump
Repair Kit
18-3214**

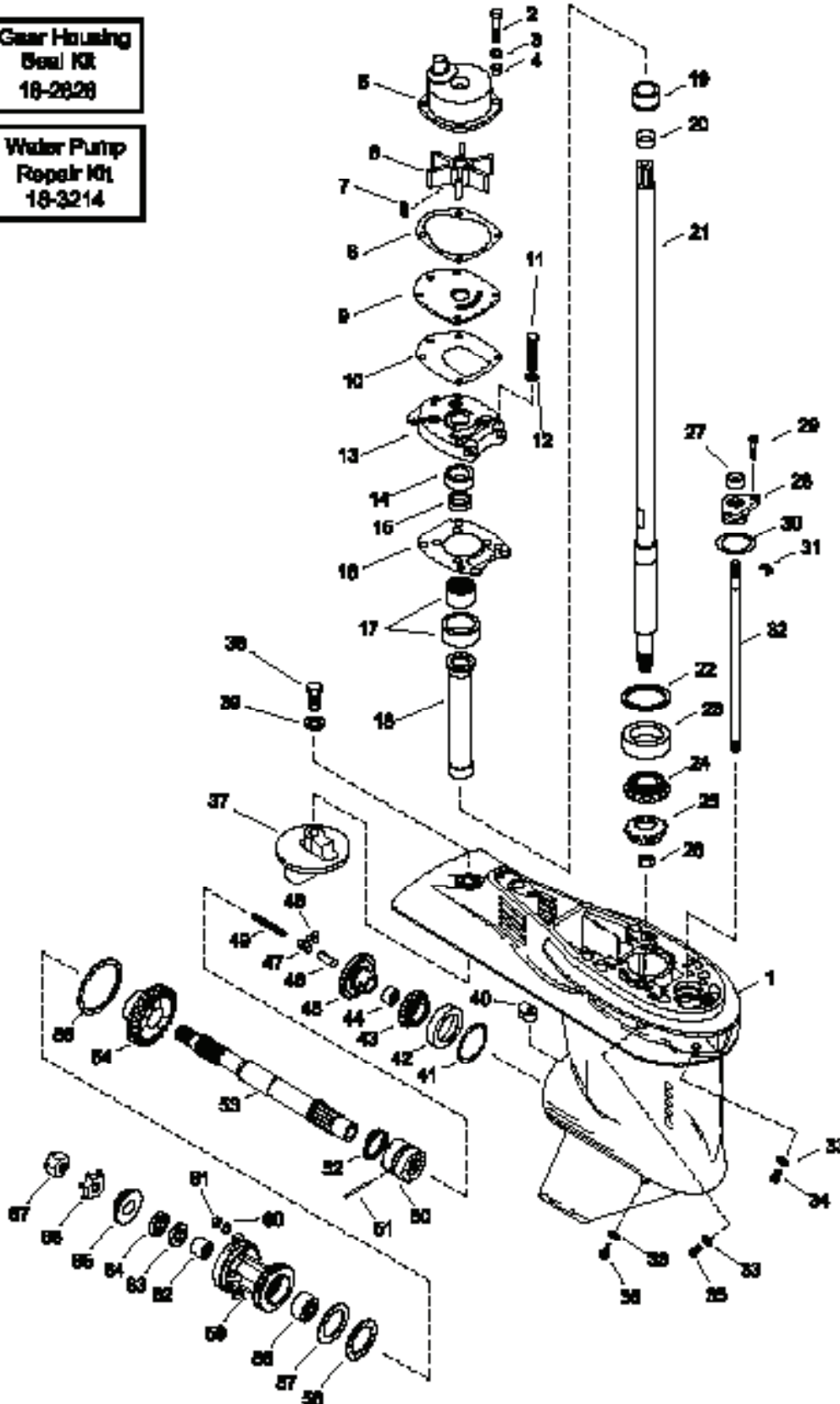

Figure #	Description	Part #	O.E.M. #	Qty.	Figure #	Description	Part #	O.E.M. #	Qty.
1	Gear Housing	—	1667-9011A73	1	49	Spring	—	24-30622	1
2	Screw	—	10-8248327	4	50	Clutch	18-2236	52-822539	1
3	Washer	18-4275	12-29245	4	51	Cross Pin	18-2357	17-30632	1
4	Insulator	18-0568	23-43045	4	52	Spring	18-2348	24-30893	1
5	Water Pump Housing	18-3572	817275A2	1	53	Prop Shaft	—	44-12238T	1
6	Impeller	18-3056	47-430262	1	54	Reverse Gear	—	43-12635	1
7	Impeller Key	18-3293	28-43037	1	55	O-Ring	18-7961	25-97386	1
8	Gasket	18-2566	27-817277	1	56	Thrust Bearing	18-1112	31-12576	1
9	Face Plate	18-3122	817276	1	57	Thrust Washer	18-1191	12-12577	1
10	Gasket	18-2564	27-430331	1	58	Roller Bearing	18-1113	31-12578	1
11	Screw	—	10-824832-6	6	59	Bearing Carrier	—	12596A2	1
12	Washer	18-4275	12-29245	6	60	Washer	—	12-70132	2
13	Pump Base	—	43055A4	1	61	Nut	—	11-401198	2
14	Seal	18-0583	26-43035	1	62	Roller Bearing	18-1158	31-30956	1
15	Seal	18-0522	26-43036	1	63	Seal	18-2002	26-76868	1
16	Gasket	18-2565	27-430472	1	64	Seal	18-2053	26-70081	1
17	Carrier w/Bearing	—	43040A1	1	65	Thrust Washer	18-4221	13191A1	1
18	Tube, Oiler	—	43046	1	66	Tab Washer	18-3200	14-31210	1
19	Sleeve	—	42461A1	1	67	Prop Nut	18-3700	11-52707	1
20	Ring	—	42461A1	1					
21	Drive Shaft	—	45-43031A1	1					
22	Shim Assembly	—	15-44492A1	AR					
23	Race (sold with #24)	18-1118	31-42677A1	1					
24	Bearing (sold with #23)	18-1118	31-42677A1	1					
25	Pinion Gear	—	43-44484	1					
26	Pinion Nut	18-3719	11-35921	1					
27	Seal	18-2054	26-8164641	1					
28	Bushing Assembly	—	23-43052A4	1					
29	Screw	—	10-824832-6	2					
30	O-Ring	18-7198	25-45710	1					
31	E-Ring	18-4295	53-29641	1					
32	Shift Shaft	—	43048A1	1					
33	Gasket	18-2945	12-19183	3					
34	Plug	—	10-28653	1					
35	Plug	18-2244	10-79953	1					
36	Plug	18-2375	22-67892A1	1					
37	Trim Tab	18-6011	31640A1	1					
38	Bolt, Anode Mounting	18-6245	10-15942	1					
39	Washer, Anode Mounting	18-4858-9	12-45176	1					
40	Shim Cam	—	76039	1					
41	Shim Assembly	—	15-44491A1	AR					
42 & 43	Bearing & Race	18-1156	13-30894A1	1					
44	Roller Bearing	18-1157	31-30895	1					
45	Forward Gear	—	43-12634A2	1					
46 & 47	Cam Follower Assembly	—	12239A1	1					
48	Ball Bearing	—	30-44530	3					
AR As required									

V-150

Serial # A904645 & earlier

V-175

Serial # 664875C

V-200

Serial # 662522C

**66 — Gear Housing Seal Kit
18-2053**

**67 — Water Pump Repair Kit
(with housing)
18-3217**

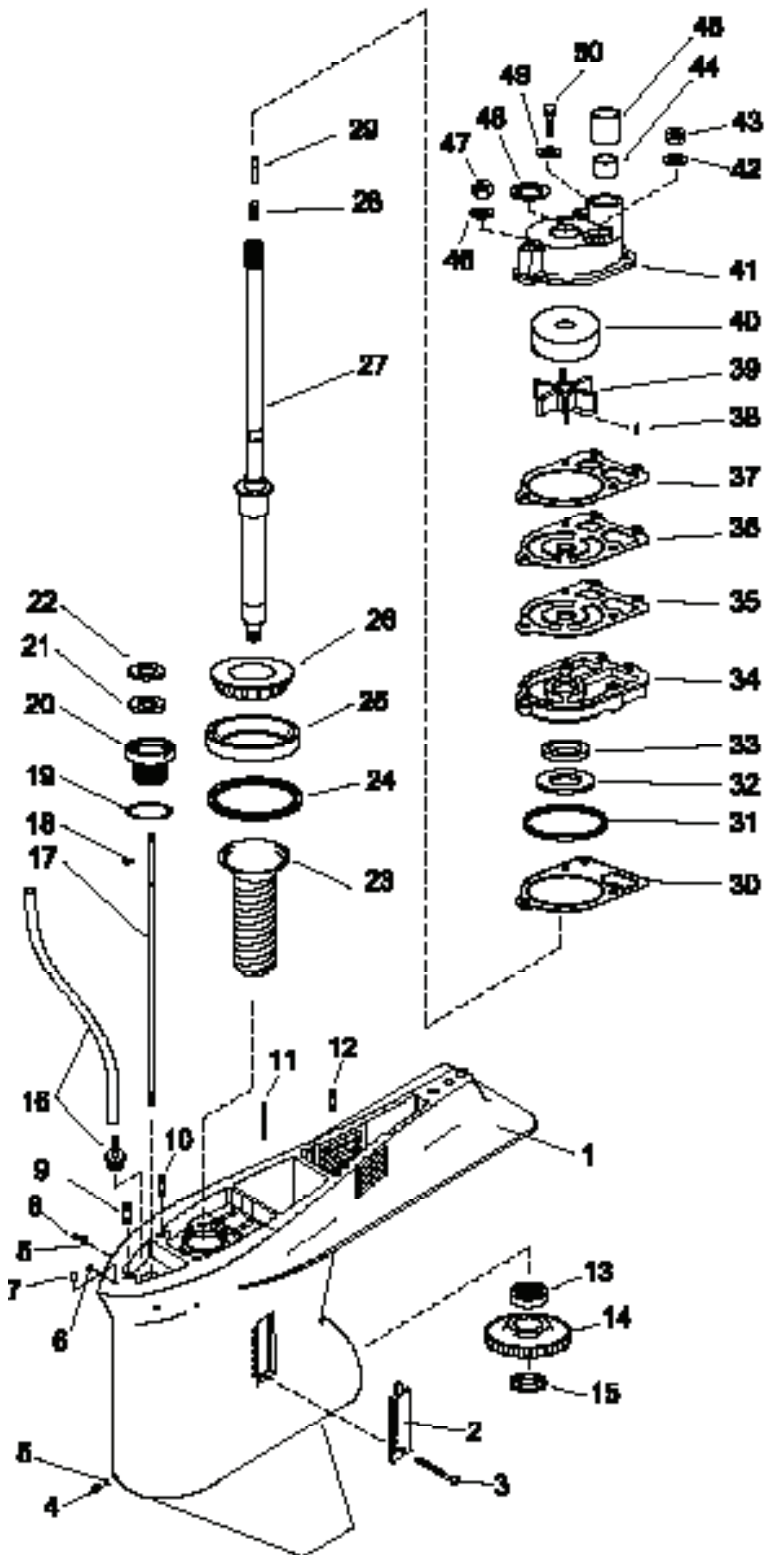

Complete Gear Housings Listed on Page 437

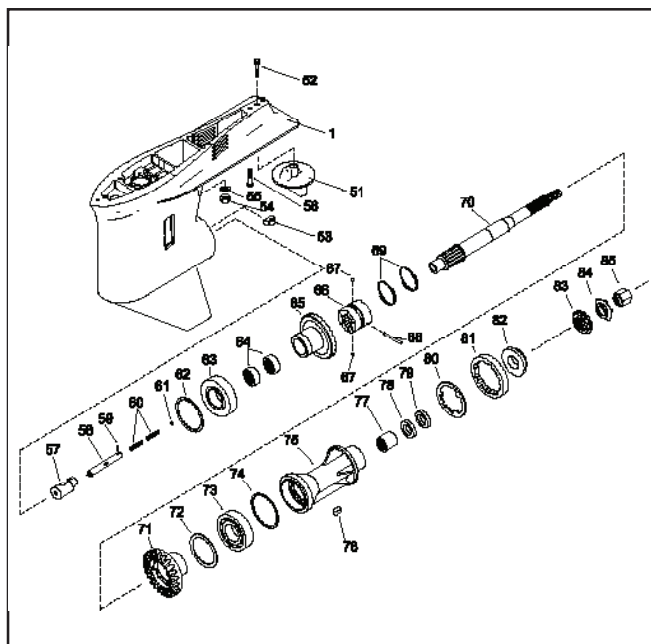

Figure #	Description	Part #	O.E.M. #	Qty.	Figure #	Description	Part #	O.E.M. #	Qty.
1	Gear Housing	~	1647-9148A65	1	34	Water Pump Base	18-3416	46-96146A6	1
2	Water Insert (Starboard)	~	66885	1	35	Gasket	18-2914	27-856081	1
	Water Insert (Port)	~	66884	1	36	Face Plate	18-3117	32435	1
3	Screw	18-3197	10-76156	1	37	Gasket	18-2915	27-856091	1
4	Drain Screw	18-2375	22-67892A1	1	38	Key	~	28-56654	1
5	Washer	18-2945	12-19183	2	39	Impeller	18-3017	47-899842	1
6	Nut	18-2344	11-45812	1	40	Insert	18-3114	48752	1
7	Dowel Pin	~	17-43044	2	41	Water Pump Body	18-3116	43-96148A1	1
8	Vent Screw	18-2244	10-79953	1	42	Washer	18-4275	12-29245	3
9	Stud	~	16-78638	1	43	Nut	18-3722	11-20361	2
10	Stud	~	16-56297	1	44	Seal	18-3110	26-38970	1
11	Stud	~	16-30667	2	45	Guide Sleeve	18-3109	23-29804	1
12	Stud	~	16-579201	2	46	Washer	18-4270	12-36001	1
13	Roller Bearing	~	31-35934A1	1	47	Nut	18-3722	11-45592	1
14	Pinion Gear	~	43-780811	1	48	Slinger	18-7426	25-30271	1
15	Pinion Nut	18-3719	11-35921	1	49	Washer	18-4275	12-29245	3
16	Speedometer Tube	~	22-85822A10	1	50	Screw	~	10-96411	1
17	Shift Shaft	~	78902 2	1	51	Trim Tab	18-6011	3164A1	1
18	E-Clip	18-4295	53-29641	1	52	Screw	~	10-66024	1
19	O-Ring	18-7153	25-25439	1	53	Shift Cam	~	78956	1
20	Shift Shaft Bushing	18-2155	23-77631A2	1	54	Nut	18-3721	11-34933	1
21	Seal	18-2054	26-816461	1	55	Washer	~	12-45176	2
22	Rubber Washer	18-2316	12-77674	1	56	Screw	~	10-65210	1
23	Sleeve	~	23-98621	1	57	Cam Follower	~	89594A1	1
24	Shim Assembly	18-2295	15-57007A1	AR	58	Actuator Rod	~	79911 1	1
25	Roller Bearing	~	31-53079A1	1	59	Locating Pin	~	17-78906	1
26	Roller Bearing	~	31-53079A1	1	60	Spring	~	24-749910	2
27	Drive Shaft Assembly	~	45-98682A1	1	61	Washer	~	12-78910	1
28	Spring	~	24-34576	1	62	Shim Assembly	18-2285	15-47397A1	AR
29	Pin	~	17-30545	1	63	Bearing	18-1166	31-78172A1	1
30	Gasket	18-2826	27-856101	1	64	Forward Gear	~	43-78082A3	1
31	O-Ring	18-7162	25-33145	1	65	Roller Bearing	18-1122	31-73363	2
32	Seal	18-2014	26-89238	1	66	Clutch	~	52-823174	1
33	Seal	18-2013	26-16977	1	67	Detent Pin	~	17-78909	2
					68	Cross Pin	~	17-78905	1
					69	Retaining Spring	~	24-78962	2
					70	Prop Shaft	18-2239	44-94148	1
					71	Reverse Gear	~	43-85462	1
					72	Thrust Ring	~	68100 1	1
					73	Ball Bearing	18-1155	30-88957	1
					74	O-Ring	18-7159	25-31534	1
					75	Bearing Carrier	18-1567	43567T1	1
					76	Key	~	28-30281	1
					77	Roller Bearing	18-1158	31-30956	1
					78	Seal (Inner)	18-2002	26-76868	1
					79	Seal (Outer)	18-2053	26-70081	1
					80	Tab Washer	18-2299	14-79447	1
					81	Cover Nut	18-3751	79448	1
					82	Thrust Hub	18-4220	13171	1
					83	Spline Washer	18-3714	12-31211A2	1
					84	Tab Washer	18-3200	14-31210	1
					85	Prop Nut	18-3700	11-52707	1

AR As required



18-1190
BALL BEARING
 Replaces: 30-20839T, 30-20839, 30-62699, FI000034
 Reverse gear for Force, Mercury, Mariner from 25-60HP (2, 3 cylinders, & 4-stroke) including 30Jet - 45Jet



18-1191
THRUST WASHER
 Replaces: 12-12577
 30-126HP



18-1111
REVERSE GEAR BEARING
 Replaces: 31-62799A1



18-1112
REVERSE GEAR THRUST BEARING
 Replaces: 31-12576



18-1113
REVERSE GEAR BEARING
 Replaces: 31-12578, 31-12578T



18-1115
PINION BEARING
 Replaces: 31-32898, 31-32898T, 31-29982



18-1117
PINION BEARING
 Replaces: 31-42647A1, 31-42647, 31-F694057



18-1118
DRIVE SHAFT BEARING
 Replaces: 31-42677A1



18-1122
INSIDE FORWARD GEAR BEARING
 Replaces: 31-73363, 31-73363T



18-1143
TAPERED ROLLER BEARING
 Replaces: 31-36387A1



18-1144
BEARING ASSEMBLY
 Replaces: 31-48939A2



18-1153
BALL BEARING
 Replaces: 30-63326, 30-63326T, 30-49313, 30-54215, 30-20464



18-1154
BALL BEARING
 Replaces: 30-63742, 30-63742T



18-1155
BALL BEARING
 Replaces: 30-88957A1, 30-88957T, 30-35914, 30-17927, 30-88957



18-1347
MAIN BEARING
 Replaces: 31-88269T
 For: 250/275/3.4L



18-1156
FORWARD GEAR BEARING
 Replaces: 31-30894A1



18-1197
TAPERED FORWARD GEAR BEARING
 Replaces: 31-828439A2
 For: Alpha One Gen II (1996-97) (s/n 0F680000-0K999999)



18-1157
FORWARD GEAR INNER BEARING
 Replaces: 31-30895, 31-30895T



18-1158
CARRIER BEARING
 Replaces: 31-30956, 31-30956T, 31-F523058



18-1159
TAPERED ROLLER BEARING
 Replaces: 31-35928A1, 31-35928T1

APPLICATION BEGINS ON NEXT PAGE



**18-1163
TAPERED ROLLER
BEARING**
Replaces: 31-48941A1

**18-1162
TAPERED ROLLER
BEARING**
Replaces: 31-38356A1, 31-F84901,
FA84901, F84903

**18-1166
TAPERED ROLLER
BEARING**
Replaces: 31-78172A1

**18-1126
TAPERED ROLLER
BEARING**
Replaces: 31-54036A1



**18-1170
LOWER PINION BEARING**
Replaces: 31-812767A1

**18-0557
SEAL CARRIER**
Replaces: 888909A1
For: All Verado's
135/150/175/200/225/250/275

**18-1567
CARRIER BEARING**
Replaces: 43567T1, 43567A1, 96184A1
Fits: V-115 DFI 2.5L (2000), V-135 (1986 & Up),
V-135 DFI 2.5L (1998 & Up), V-150 (1978 & Up),
V-150 EFI (1996-01), V-150 DFI 2.5L (1998 & Up),
V-175 (1976-99), V-175 EFI (1996-01), V-175 DFI 2.5L
(2001 & Up), V-200 (1978 & Up), V-200 EFI (1989-01),
V-200 EFI 2.5L (2002 & Up), XR-6 (1992-99)

**18-2370
CARRIER BEARING**
Replaces: 19291A3
(Force 40/50 HP 1995-99, 70 HP 1991-95,
75 HP 1996-98) (Mercury/Mariner 30/40
HP 2 cyl 9854537-P016999, 30/40 4-stroke
G760300-up, 40/50 HP/30Jet 3 cyl 9973100-
up, 60 HP 3 cyl D000750-up, 60 HP 4-stroke
9973100-up)

Model	Serial Number	Bearing (Drive Shaft)	Bearing Pinion	Inside Bearing Forward Gear	Outside Bearing Forward Gear	Bearing Reverse Gear	Thrust Bearing Reverse Gear	Bearing Model Carrier
30 (4-stroke, Bigfoot)	G760300 & Up	18-1118	—	18-1157	18-1156	18-1113	18-1112	18-1158
30 (4-stroke, non-Bigfoot)	G760300 & Up	—	—	—	18-1107	—	—	—
30 EFI (4-stroke, Bigfoot)	T409000 & Up	18-1118	—	18-1157	18-1156	18-1113	18-1112	18-1158
30 EFI (4-stroke, non-Bigfoot)	T409000 & Up	—	—	—	18-1107	—	—	—
35 (2 cyl.)	6445653 & Up	—	—	—	18-1162	—	N/A	—
350	1960827 - 2874703	—	—	18-1162	—	N/A	—	—
400 (2 cyl.)	2874704 - 3336257	—	—	—	18-1162	—	N/A	—
402	3336258 - 4117709	—	—	—	18-1162	—	N/A	—
402	4117710 - 4860102	—	—	—	18-1162	—	N/A	—
402/40 (2 cyl.)	4860103 - 5556229	—	—	—	18-1162	—	N/A	—
40 (2 cyl.)	5556230 - G053313	—	—	—	18-1162	—	N/A	—
40 (4 cyl.)	C159200 & Up	—	—	—	18-1162	—	N/A	—
40 (4-stroke, Bigfoot)	G231123 & Up	18-1118	—	18-1157	18-1156	18-1113	18-1112	18-1158
40 (4-stroke, non-Bigfoot)	G231123 & Up	—	—	—	18-1107	—	—	—
40 (4-stroke, 4 cyl. Bigfoot)	T228405 & Up	18-1118	—	18-1157	18-1156	18-1113	18-1112	18-1158
40 (4-stroke, 4 cyl. non-Bigfoot)	T228405 & Up	—	—	—	18-1170	—	—	—
40 EFI (4-stroke, 3 cyl. non-Bigfoot)	T409000 & Up	—	—	—	18-1103	18-1190	—	—
40 EFI (4-stroke, 3 cyl. Bigfoot)	T409000 & Up	18-1118	—	18-1157	18-1156	18-1113	18-1112	18-1158
40 EFI (4-stroke, 4 cyl. non-Bigfoot)	T409000 & Up	—	—	—	18-1170	—	—	—
45 (4 cyl.)	5531630 & Up	—	—	—	18-1162	—	N/A	—
45 (Bodensee 4-stroke, Bigfoot)	G231123 - T178499	18-1118	—	18-1157	18-1156	18-1113	18-1112	18-1158
45 (Bodensee 4-stroke, non-Bigfoot)	G231123 - T178499	—	—	—	18-1103	—	—	—
500	2305101 - 2858813	—	—	—	18-1162	—	N/A	—
500	2858814 - 4140999	—	—	—	18-1162	—	N/A	—
500	4141000 - 4357639	—	—	—	18-1162	—	N/A	—
500 / 50	4357640 - 4962055	—	—	—	18-1162	—	N/A	—
500 / 50	4962056 - 5531629	—	—	—	18-1162	—	N/A	—
50 (4 cyl.)	5531630 & Up	—	—	—	18-1162	—	N/A	—
50 (3 cyl.)	6428681 - D000749	—	—	—	18-1162	—	N/A	—
50 (3 cyl.)	D000750 - G589999	—	—	—	18-1170	—	N/A	—
50 (4-stroke, Bigfoot)	G231123 & Up	18-1118	—	18-1157	18-1156	18-1113	18-1112	18-1158
50 (4-stroke, non-Bigfoot)	G231123 & Up	—	—	—	18-1107	—	—	—

① Standard Rotation Only.

③ For Units With A Casting Number Of 1655-9572C Only.

④ For Units With A Casting Number Of 1674-814247C Only.

⑤ Two Bearings Required.

⑥ For 5/8 Dual Bearing Application.

⑦ Use 18-1155 For Counter Rotation Applications.

Model	Serial Number	Bearing (Drive Shaft)	Bearing Pinion	Inside Bearing Forward Gear	Outside Bearing Forward Gear	Bearing Reverse Gear	Thrust Bearing Reverse Gear	Bearing Model Carrier
30 (4-stroke, Bigfoot)	G760300 & Up	18-1118	—	18-1157	18-1156	18-1113	18-1112	18-1158
30 (4-stroke, non-Bigfoot)	G760300 & Up	—	—	—	18-1107	—	—	—
30 EFI (4-stroke, Bigfoot)	T409000 & Up	18-1118	—	18-1157	18-1156	18-1113	18-1112	18-1158
30 EFI (4-stroke, non-Bigfoot)	T409000 & Up	—	—	—	18-1107	—	—	—
35 (2 cyl.)	6445653 & Up	—	—	—	18-1162	—	N/A	—
350	1960827 - 2874703	—	—	18-1162	—	N/A	—	—
400 (2 cyl.)	2874704 - 3336257	—	—	—	18-1162	—	N/A	—
402	3336258 - 4117709	—	—	—	18-1162	—	N/A	—
402	4117710 - 4860102	—	—	—	18-1162	—	N/A	—
402/40 (2 cyl.)	4860103 - 5556229	—	—	—	18-1162	—	N/A	—
40 (2 cyl.)	5556230 - G053313	—	—	—	18-1162	—	N/A	—
40 (4 cyl.)	C159200 & Up	—	—	—	18-1162	—	N/A	—
40 (4-stroke, Bigfoot)	G231123 & Up	18-1118	—	18-1157	18-1156	18-1113	18-1112	18-1158
40 (4-stroke, non-Bigfoot)	G231123 & Up	—	—	—	18-1107	—	—	—
40 (4-stroke, 4 cyl. Bigfoot)	T228405 & Up	18-1118	—	18-1157	18-1156	18-1113	18-1112	18-1158
40 (4-stroke, 4 cyl. non-Bigfoot)	T228405 & Up	—	—	—	18-1170	—	—	—
40 EFI (4-stroke, 3 cyl. non-Bigfoot)	T409000 & Up	—	—	—	18-1103	18-1190	—	—
40 EFI (4-stroke, 3 cyl. Bigfoot)	T409000 & Up	18-1118	—	18-1157	18-1156	18-1113	18-1112	18-1158
40 EFI (4-stroke, 4 cyl. non-Bigfoot)	T409000 & Up	—	—	—	18-1170	—	—	—
45 (4 cyl.)	5531630 & Up	—	—	—	18-1162	—	N/A	—
45 (Bodensee 4-stroke, Bigfoot)	G231123 - T178499	18-1118	—	18-1157	18-1156	18-1113	18-1112	18-1158
45 (Bodensee 4-stroke, non-Bigfoot)	G231123 - T178499	—	—	—	18-1103	—	—	—
500	2305101 - 2858813	—	—	—	18-1162	—	N/A	—
500	2858814 - 4140999	—	—	—	18-1162	—	N/A	—
500	4141000 - 4357639	—	—	—	18-1162	—	N/A	—
500 / 50	4357640 - 4962055	—	—	—	18-1162	—	N/A	—
500 / 50	4962056 - 5531629	—	—	—	18-1162	—	N/A	—
50 (4 cyl.)	5531630 & Up	—	—	—	18-1162	—	N/A	—
50 (3 cyl.)	6428681 - D000749	—	—	—	18-1162	—	N/A	—
50 (3 cyl.)	D000750 - G589999	—	—	—	18-1170	—	N/A	—
50 (4-stroke, Bigfoot)	G231123 & Up	18-1118	—	18-1157	18-1156	18-1113	18-1112	18-1158
50 (4-stroke, non-Bigfoot)	G231123 & Up	—	—	—	18-1107	—	—	—
50 EFI (4-stroke, non-Bigfoot)	T409000 & Up	—	—	—	18-1107	—	—	—
50 EFI (4-stroke, Bigfoot)	T409000 & Up	18-1118	—	18-1157	18-1156	18-1113	18-1112	18-1158
55 (3 cyl.)	D000750 - G589999	—	—	—	18-1170	—	N/A	—
55 Seapro, Marathon, Pontoon	D000750 & Up	18-1118	—	18-1157	18-1156	18-1113	18-1112	18-1158
60 (3 cyl.)	6428681 - D000749	—	—	—	18-1162	—	N/A	—
60 (3 cyl.)	D000750 - G589999	—	—	—	18-1170	—	N/A	—
60 EFI (4-stroke, non-Bigfoot)	T409000 & Up	—	—	—	18-1103	—	—	—
60 EFI (4-stroke, Bigfoot)	T409000 & Up	18-1118	—	18-1157	18-1156	18-1113	18-1112	18-1158
650 (4 cyl.)	1542745 - 1765403	18-1153	—	18-1157	18-1156	—	N/A	18-1158
650 (4 cyl.)	2119749 - 2309310	18-1153	—	18-1157	18-1156	—	N/A	18-1158
650 (4 cyl.)	2309311 - 2452709	18-1153	—	18-1157	18-1156	—	N/A	18-1158
650 (4 cyl.)	2503991 - 2803561	18-1153	—	18-1157	18-1156	—	N/A	18-1158
650 (4 cyl.)	2803562 - 2874263	—	—	18-1157	18-1156	—	N/A	18-1158
650 (4 cyl.)	2997339 & Up	—	—	18-1157	18-1156	—	N/A	18-1158
650 (3 cyl.)	3293184 - 3525440	—	—	—	18-1162	—	N/A	—
650 (3 cyl.)	3547987 - 4571651	—	—	—	18-1162	—	N/A	—
70 (3 cyl.)	4571652 - 4977156	—	—	—	18-1162	—	N/A	—
70 (3 cyl.)	4977157 - 5579016	—	—	—	18-1162	—	N/A	—
70 (3 cyl.)	5579017 - 6428680	—	—	—	18-1162	—	N/A	—
70 (3 cyl.)	A996142 - & Up	18-1118	N/A	18-1157	18-1156	18-1113	18-1112	18-1158
75 (4 cyl.)	6432901 & Up	—	—	18-1157	18-1156	N/A	N/A	18-1158
75 (3 cyl.)	A996142 - & Up	18-1118	N/A	18-1157	18-1156	18-1113	18-1112	18-1158
800 (4 cyl.)	2559001 - 3144218	18-1153	—	18-1157	18-1156	—	N/A	18-1158
800 (4 cyl.)	3144219 - 3493912	—	—	18-1157	18-1156	—	N/A	18-1158
80 (4 cyl.)	4831999 - 6432900	—	—	18-1157	18-1156	N/A	N/A	18-1158
80 (3 cyl.)	A996142 & Up	18-1118	N/A	18-1157	18-1156	18-1113	18-1112	18-1158
850 (4 cyl.)	3493913 - 4831998	—	—	18-1157	18-1156	—	N/A	18-1158
900 (6 cyl.)	1766824 - 1869775	18-1153	—	18-1157	18-1156	—	N/A	18-1158
900/90 (6 cyl.)	4845301 - & Up	—	—	18-1157	18-1156	N/A	N/A	18-1158
90 (3 cyl.)	A996142 & Up	18-1118	N/A	18-1157	18-1156	18-1113	18-1112	18-1158

① Standard Rotation Only.

③ For Units With A Casting Number Of 1655-9572C Only.

④ For Units With A Casting Number Of 1674-814247C Only.

⑤ Two Bearings Required.

⑥ For 5/8 Dual Bearing Application.

⑦ Use 18-1155 For Counter Rotation Applications.

⑧ Using pinion stamped 43-19672.

Model	Serial Number	Bearing (Drive Shaft)	Bearing Pinion	Inside Bearing Forward Gear	Outside Bearing Forward Gear	Bearing Reverse Gear	Thrust Bearing Reverse Gear	Bearing Model Carrier
100 (4 cyl.)	B209468 - & Up	18-1118	N/A	18-1157	18-1156	18-1113	18-1112	18-1158
1150	2836019 - 2933900	18-1153	—	18-1157	18-1156	—	N/A	18-1158
1150	2933901 - 3525440	18-1153	—	18-1157	18-1156	—	N/A	18-1158
1150	3525441 - 4112634	18-1153	—	18-1157	18-1156	—	N/A	18-1158
1150	4112635 - 4855152	—	—	18-1157	18-1156	—	N/A	18-1158
1150 / 115	4855153 - 5314655	—	—	18-1157	18-1156	N/A	N/A	18-1158
115 (6 cyl.)	5314656 - 5600966	—	—	18-1157	18-1156	N/A	N/A	18-1158
115 (6 cyl.)	5600967 - 6436122	—	—	18-1157	18-1156	N/A	N/A	18-1158
115 (6 cyl.)	6436123 & Up	—	—	18-1157	18-1156	N/A	N/A	18-1158
115 (4 cyl.)	C100000 & Up	18-1118	N/A	18-1157	18-1156	18-1113	18-1112	18-1158
125 (4 cyl.)	0T627234 & Below ⑧	18-1118	N/A	18-1157	18-1156	18-1113	18-1112	18-1158
1250	2314956 - 2839368	18-1153	—	18-1157	18-1156	—	N/A	18-1158
1350	2839369 - 2940020	18-1153	—	18-1157	18-1156	—	N/A	18-1158
1350	2940021 - 3293233	18-1153	—	18-1157	18-1156	—	N/A	18-1158
1400	3293234 - 3502805	18-1153	—	18-1157	18-1156	—	N/A	18-1158
140	4865687 & Up	—	—	18-1157	18-1156	N/A	N/A	18-1158
1500	3502806 - 4121434	18-1153	—	18-1157	18-1156	—	N/A	18-1158
1500	4121435 - 4865677	—	—	18-1157	18-1156	—	N/A	18-1158
V-135	A904646 & Up	18-1143	18-1117	18-1122 ⑤	18-1166	18-1155	N/A	18-1158
V-135	C100861 & Up	18-1143	18-1117	18-1122 ⑤ ①	18-1166 ① ⑦	18-1155 ①	N/A	18-1158
V-135	C239553 & Up	18-1143	18-1117	18-1122 ⑥ ①	18-1166 ① ⑦	18-1155 ①	N/A	18-1158
V-135	D082000 & Up	18-1143	18-1117	18-1115 ①	18-1166 ① ⑦	18-1155 ①	N/A	18-1158
V-150	4868998 - 5432021	—	—	18-1122 ⑤	18-1166	18-1155	N/A	18-1158
V-150	5432022 - 6042945	—	—	18-1122 ⑤	18-1166	18-1155	N/A	18-1158
V-150	6042946 - 6443212	—	—	18-1122 ⑤	18-1166	18-1155	N/A	18-1158
V-150	6443213 - 6616990	—	—	18-1122 ⑤	18-1166	18-1155	N/A	18-1158
V-150	6616991 - A904645	—	—	18-1122 ⑤	18-1166	18-1155	N/A	18-1158
V-150	A904646 & Up	18-1143	18-1117	18-1122 ⑤	18-1166	18-1155	N/A	18-1158
V-150	C100861 & Up	18-1143	18-1117	18-1122 ⑤ ①	18-1166 ①	18-1155	N/A	18-1158
V-150	C239553 & Up	18-1143	18-1117	18-1122 ⑤ ①	18-1166 ① ⑦	18-1155 ①	N/A	18-1158
V-150	D082000 & Up	18-1143	18-1117	18-1115 ①	18-1166 ① ⑦	18-1155 ①	N/A	18-1158
V-150XRI (EFI)	D082000 & Up	18-1143	—	18-1157	18-1156 ①	N/A	N/A	18-1158
V-150XRI (EFI)	D082000 & Up	18-1143	18-1117	18-1115 ⑤ ①	18-1166 ① ⑦	18-1155 ①	N/A	18-1158
V-150XRI (EFI)	D082000 & Up	18-1143	18-1117	18-1115 ⑤ ①	18-1166 ① ⑦	18-1155 ①	N/A	18-1158
V-175	4301235 - 5393736	—	—	18-1122 ⑤	18-1166	18-1155	N/A	18-1158
V-175	5393737 - 6618750	—	—	18-1122 ⑤	18-1166	18-1155	N/A	18-1158
V-175	6618751 & Up	18-1143	18-1117	18-1122 ⑤	18-1166	18-1155	N/A	18-1158
V-175	C100861 & Up	18-1143	18-1117	18-1122 ⑤ ①	18-1166 ① ⑦	18-1155 ①	N/A	18-1158
V-175	C239553 & Up	18-1143	18-1117	18-1122 ⑥ ①	18-1166 ① ⑦	18-1155 ①	N/A	18-1158
V-175	D082000 & Up	18-1143	18-1117	18-1115 ①	18-1166 ① ⑦	18-1155 ①	N/A	18-1158
V-175XRI (EFI)	D000750 & Up	18-1143	18-1117	18-1122 ⑤ ⑥	18-1166	18-1155	N/A	18-1158
V-175XRI (EFI)	D000750 & Up	18-1143	18-1117	18-1122 ⑤ ⑥	18-1166	18-1155	N/A	18-1158
V-175XRI (EFI)	D082000 & Up	18-1143	—	18-1157	18-1156 ①	N/A	N/A	18-1158
V-175XRI (EFI)	D082000 & Up	18-1143	18-1117	18-1115 ⑤ ①	18-1166 ① ⑦	18-1155 ①	N/A	18-1158
V-175XRI (EFI)	D082000 & Up	18-1143	18-1117	18-1115 ⑤ ①	18-1166 ① ⑦	18-1155 ①	N/A	18-1158
V-200	4839034 - 5363917	—	—	18-1122 ⑤	18-1166	18-1155	N/A	18-1158
V-200	5363918 - 6073191	—	—	18-1122 ⑤	18-1166	18-1155	N/A	18-1158
V-200	6073192 - 6203990	—	—	18-1122 ⑤	18-1166	18-1155	N/A	18-1158
V-200	6203991 - 6435502	—	—	18-1122 ⑤	18-1166	18-1155	N/A	18-1158
V-200	6435503 - 6625220	—	—	18-1122 ⑤	18-1166	18-1155	N/A	18-1158
V-200	6625221 - C100860	18-1143	18-1117	18-1122 ⑤	18-1166	18-1155	N/A	18-1158
V-200/								
V-200 (EFI)	C100861 - C291519	18-1143	18-1117	18-1122 ⑤	18-1166	18-1155	N/A	18-1158
V-200 (2.5L)	C291520 - D081999	18-1143	18-1117	18-1122 ⑥ ①	18-1166 ① ⑦	18-1155 ①	N/A	18-1158
V-200	D082000 & Up	18-1143	18-1117	18-1115 ①	18-1166 ① ⑦	18-1155 ①	N/A	18-1158
V-200XRI (EFI)	C291520 & Up	18-1143	18-1117	18-1122 ⑤	18-1166	18-1155	N/A	18-1158
V-200XRI (EFI)	D082000 & Up	18-1143	—	18-1157	18-1156 ①	N/A	N/A	18-1158
V-200XRI (EFI)	D082000 & Up	18-1143	18-1117	18-1115 ⑤ ①	18-1166 ① ⑦	18-1155 ①	N/A	18-1158
V-200XRI (EFI)	D082000 & Up	18-1143	18-1117	18-1115 ⑤ ①	18-1166 ① ⑦	18-1155 ①	N/A	18-1158
V-220	B117316 & Up	18-1143	18-1117	18-1122 ⑤	18-1166	18-1155	N/A	18-1158
V-225	5628028 & Up	—	—	18-1122 ⑤	18-1166	18-1155	N/A	18-1158
225	D280813 & Up	18-1143	18-1117	18-1157 ①	18-1159 ①	18-1155 ①	N/A	18-1158
XR-4 ③	B242885 & Up	18-1143	—	18-1157	18-1156	N/A	N/A	18-1158
XR-4	B242885 & Up	18-1143	—	18-1157	18-1156	N/A	N/A	18-1158
XR-4 ③	C100861 & Up	18-1143	—	18-1157	18-1156	N/A	N/A	18-1158
XR-4 ④	C100861 & Up	18-1143	—	18-1157	18-1156	N/A	N/A	18-1158
XR-4	C239553 & Up	18-1143	—	18-1157	18-1156	N/A	N/A	18-1158
XR-6	D082000 & Up	18-1143	—	18-1157	18-1156	N/A	N/A	18-1158

- ① Standard Rotation Only.
- ② For Units With A Casting Number Of 1655-9572C Only.
- ③ For Units With A Casting Number Of 1674-814247C Only.
- ④ For Units With A Casting Number Of 1674-814247C Only.
- ⑤ Two Bearings Required.
- ⑥ For 5/8 Dual Bearing Application.
- ⑦ Use 18-1155 For Counter Rotation Applications.
- ⑧ Using pinion stamped 43-19672.

 <p>18-2244 18-22441-9① (PKG. OF 50 WITHOUT GASKET) DRAIN PLUG • 3/8" -16 thread Replaces: 10-20259, 10-28634, 10-28634A1, 10-79953A2, 10-79953Q2, 10-79953, 10-79953Q04, 816610A1, 816610A2, F40109, 10-F50109 Includes gasket 18-2945</p>	 <p>② 18-2375D  18-23751-9① (PKG. OF 50 WITHOUT GASKET) DRAIN PLUG • 3/8" -16 thread Replaces: 10-14834, 10-14834A1, 22-67892, 22-67892A1, 22-67892A05, 22-67892A06, 28-8M0058389 Includes gasket 18-2945</p>	 <p>18-2155 SHIFT SHAFT HOUSING BUSHING Replaces: 23-37428A1, 23-55419A1, 23-77631A2 35-200 HP</p>
① Priced per Package ② Items ending in "D" are Display Packaged - Regular number is Non-Display		



18-3719

PINION NUT

Replaces: 11-35921, 11-47411, 11-826375, 11-F694188
5/8" - 18 thread • 1 1/16" wrench



18-2359
DRIVE SHAFT NUT SET

— INCLUDES —

Sierra #	Description	Replaces:
18-3719	Pinion Nut	11-35921
18-2343	Pinion Nut Washer	12-92721
18-2343-9	Pinion Nut Washer	12-92721

② Priced per Package



18-1736

DRIVESHAFT ASSEMBLY

Replaces: 45-43031A1
Fits: 100 4 cyl (1988 & Up), 115 4 cyl (1989 & Up), 125 4 cyl (1994 & Up)



18-1737

DRIVESHAFT (32 1/4" long)

Replaces: 45-440001
Fits: V-115 DFI 2.5L (2000), V-135 (1986 & Up), V-135 DFI 2.5L (1998 & Up), V-150 (1978 & Up), V-150 EFI (1996-01), V-150 Mag/EFI (1993-95), V-150 DFI 2.5L (1998 & Up), V-150 Mag (1980-85), V-175 (1976-99), V-175 EFI (1996 & Up), V-175 Mag/EFI (1991-95), V-175 DFI 2.5L (2001 & Up), V-175 XRI EFI (1991-95), V-200 (1978 & Up), V-200 EFI (1989-01), V-200 Mag/EFI (1992-95), V-200 EFI 2.5L (2002 & Up), V-200 XRI/EFI (1991-95), XR-4 (1988-91), XR-6 (1992 & Up)



18-2239

PROP SHAFT

Replaces: 44-94148



18-2254

PROP SHAFT

Replaces: 44-850308



18-2260

PROP SHAFT

Replaces: 44-17915



18-2236

SLIDING CLUTCH

Replaces: 52-12777, 52-34239, 52-814756, 52-822539, 52-822539T



18-1550

COMPLETE GEAR SET

Replaces: 43-850036T, 43-881260A3, 52-850048T

Forward, Pinion, Reverse and Clutch for 4 cyl.: **Fits:** 100 4 cyl with 6 JAW reverse clutch(1988-98), 115 4 cyl with 6 JAW reverse clutch(1989-98), 125 4 cyl with 6 JAW reverse clutch(1994-98) (2.07:1 Ratio)



18-1551

COMPLETE GEAR SET

Replaces: 43-803615T2, 52-859340T, 43-828175A1
Forward, Pinion, Reverse and Clutch for V-6:

Fits: V-150 (XR6, Mag III)(1997 & Up), V-150 EFI (1997 & Up), V150 DFI (1998 & Up), V-175 (1997 & Up), V-175 EFI (1997 & Up), V-175 DFI (2001 & Up), V-200 (1997 & Up), V-200EFI 2.5L (1997 & Up) (1.87:1 Ratio)



18-1560

REVERSE GEAR

Replaces: 43-850036T, 43-850036

Fits: 75 4-Stroke (2000-02), 90 4-Stroke (2000-02), 100 4 cyl with 6 JAW Rev Clutch (1988 & Up), 115 4 cyl with 6 JAW Rev Clutch (1989 & Up), 115 4-Stroke EFI (2001 & Up), 125 4 cyl with 6 JAW Rev Clutch (1994 & Up) (2.07:1 Ratio)



18-1562

CLUTCH

Replaces: 52-850048T, 53-850048

Fits: 40 4-Stroke 4cyl Bigfoot(2001 & Up), 50 4-Stroke Bigfoot (1995 & Up), 60 3 cyl with 6 JAW Rev (1998 & Up), 60 4-Stroke Bigfoot (2001 & Up), 70 3 cyl with 6 JAW Rev Clutch (1987 & Up), 75 3 cyl with 6 JAW Clutch (1990-98), 75 3 cyl (1999 & Up), 75 4-Stroke 1596cc (2000-03), 80 3 cyl with 6 JAW Rev Clutch (1987 & Up), 90 3 cyl with 6 JAW Rev Clutch (1987-98), 90 3 cyl (1999 & Up), 90 4-Stroke 1596cc (2000-03), 100 4 cyl w 6 JAW Rev Clutch (1988-98), 100 4 cyl (1999 & Up), 115 4 cyl with 6 JAW Rev Clutch (1989-98), 115 4 cyl (1999 & Up), 115 4-Stroke 1741cc (2001-03), 125 4 cyl with 6 JAW Rev Clutch (1994-98), 125 4 cyl (1999 & Up)



18-1564

GEAR SET

Replaces: 43-803615T2, 43-803615T1

Fits: V-150 (1978 & Up), V-150 EFI (1996-01), V-150 DFI 2.5L (1998 & Up), V-150 EFI 2.5L (2002 & Up), V-175 EFI (1996-01), V-175 DFI 2.5L (2001 & Up), V-175 EFI 2.5L (2002-03), V-200 (1978 & Up), V-200 EFI (1989-01), V-200 EFI 2.5L (2002 & Up) (1.87:1 Ratio)

SHAFT APPLICATION BEGINS ON NEXT PAGE



**18-1565
CLUTCH**
Replaces: 52-859340T
Fits: V-115 DFI 2.5L (2000), V-135 (1986 & Up), V-135 DFI 2.5L (1998 & Up), V-150 (1978 & Up), V-150 EFI (1996-01), V-150 Mag/EFI (1993-95), V-150 DFI 2.5L (1998 & Up), V-150 Mag (1980-85), V-175 (1976-99), V-175 EFI (1996 & Up), V-175 Mag/EFI (1991-95), V-175



**18-1566
REVERSE GEAR**
Replaces: 43-828175A1
Fits: V-150 (1978 & Up), V-150 EFI (1996-01), V-150 DFI 2.5L (1998 & Up), V-175 (1976-99), V-175 EFI (1996-01), V-175 DFI 2.5L (2001 & Up), V-200 (1978 & Up), V-200 EFI (1989-01), V-200 EFI 2.5L (2002 & Up), XR-6 (1992-99) (1.87:1 Ratio)



**18-4830
GEAR HOUSING ASSEMBLY**
Replaces: 1667-9011G59
Fits: 100 4cyl (1988-99), 115 4cyl (1989 & Up), 115 3cyl DFI (2004 & Up), 115 EFI 4-Stroke(2001 & Up), 125 4cyl (1994 & Up), 30 4-Stroke (1999-01), 30 Carb 3cyl 4-Stroke (2002 & Up), 40 4-Stroke (1998-01), 40 4-Stroke 4cyl (2001-02), 40 Carb 3cyl 4-Stroke (2002 & Up), 40 EFI 4cyl 4-Stroke (2002 & Up), 40 Jet (2001 & Up), 45 Jet (1994-98), 50 4-Stroke (1995-00), 50 4cyl 4-Stroke (2001-02), 50 Bigfoot 4-Stroke(1995-00), 50 EFI 4cyl 4-Stroke (2002 & Up), 55 3cyl (1996 & Up), 60 3cyl (1984 & Up), 60 3cyl Bigfoot (1998), 60 4cyl 4-Stroke (2001-02), 60 EFI 4cyl 4-Stroke (2002 & Up), 65 Jet (1994 & Up), 75 3cyl (1987 & Up), 75 4-Stroke (2000 & Up), 75 3cyl 1.5L DFI (1995 & Up), 80 Jet (1994 & Up), 90 3cyl (1987 & Up), 90 4-Stroke (2000 & Up), 90 3cyl 1.5L DFI (2004 & Up) with 6 Jaw Clutch (Design II)

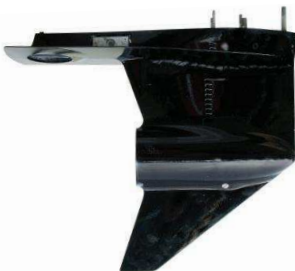

**18-4832
GEAR HOUSING ASSEMBLY**
Replaces: 1647-9148T93
Fits: 140 Jet (All), Magnum III (1992-99), V-115 DFI 2.5L (2000), V-135 (1986 & Up), V-135 DFI 2.5L (1998 & Up), V-150 (1978 & Up), V-150 EFI (1996-01), V-150 DFI 2.5L (1998 & Up), V-175 (1976-99), V-175 EFI (1996-01), V-175 DFI 2.5L (2001 & Up), V-200 (1978 & Up), V-200 EFI (1989-01), V-200 EFI 2.5L (2002 & Up), XR6 (1992 & Up)



**18-4850
COMPLETE GEARCASE**
Replaces: 1667-9011G77, 1667-9011G78, 1667-9011G10, 1667-9011G11, 1667-9011G51, 1667-9011J6, 1667-9011R6
Fits: 100/115/125 4-cyl with 6 Jaw Clutch (Design II) (2.07:1 Ratio)



**18-4851
COMPLETE GEARCASE**
Replaces: 1647-6693A3, 1647-7350A5, 1647-7350A26, 1647-8688A1, 1647-9148A69, 1647-9148A8, 1647-9148A84, 1647-9148T84, 1647-9148R84
Fits: 135/150/200/225 V6 (1.87:1 Ratio)

MERCURY OUTBOARD LOWER UNIT APPLICATIONS

Model	Serial Number	Drive Shaft	Pinion Nut	Propeller Shaft	Clutch
40 Four Stroke - BigFoot	0T178500 - 1B226999		18-3719	18-2254	18-1562
50 Four Stroke - BigFoot	0G231123 - 1B226999		18-3719	18-2254	18-1562
60 Sea Pro/Marathon/BigFoot	0G590000 & UP		18-3719	18-2254	18-1562 ④
60 Four Stroke - BigFoot	0T178500 - 1B226999		18-3719	18-2254	18-1562
650 (4 cyl.)	1542745 - 1765403	N.L.A.	—	—	18-2236
650 (4 cyl.)	2119749 - 2309310	—	—	—	18-2236
650 (4 cyl.)	2309311 - 2452709	—	18-3719	—	18-2236
650 (4 cyl.)	2503991 - 2803561	—	18-3719	—	18-2236
650 (4 cyl.)	2803562 - 2874263	—	18-3719	—	18-2236
650 (4 cyl.)	2997339 & Up	—	18-3719	—	18-2236
70 (3 cyl.)	A996142 - & Up	—	18-3719	—	18-2236 ⑤
70 (3 cyl.)	A996142 - & Up	—	18-3719	18-2254	18-1562
75 (4 cyl.)	6432901 & Up	—	18-3719	—	18-2236
75 (3 cyl.)	A996142 - & Up	—	18-3719	—	18-2236 ⑤
75 (3 cyl.)	A996142 - 0G760299	—	18-3719	18-2254	18-1562
75 (3 cyl.)	0G760300 & Up	—	18-3719	18-2254	18-1562
75 DFI	0T980000 & Up	—	18-3719	18-2254	18-1562
75 Four Stroke	0G960500 - 0T800999	—	18-3719	18-2254	18-1562
800 (4 cyl.)	2559001 - 3144218	—	18-3719	—	18-2236
800 (4 cyl.)	3144219 - 3493912	—	18-3719	—	18-2236
80 (4 cyl.)	4831999 - 6432900	—	18-3719	—	18-2236
80 (3 cyl.)	A996142 & Up	—	18-3719	—	18-2236 ⑤
80 (3 cyl.)	A996142 & Up	—	18-3719	18-2254	18-1562 ④
850 (4 cyl.)	3493913 - 4831998	—	18-3719	—	18-2236
900 (6 cyl.)	1766824 - 1869775	N.L.A.	—	—	18-2236
900/90 (6 cyl.)	4845301 - & Up	—	18-3719	—	18-2236
90 (3 cyl.)	A996142 - 0G760299	—	18-3719	—	18-2236 ⑤
90 (3 cyl.)	A996142 - 0G760299	—	18-3719	18-2254	18-1562 ④
90 (3 cyl.)	0G760300 & Up	—	18-3719	18-2254	18-1562
90 DFI	0T801000 & Up	—	18-3719	18-2254	18-1562
90 Four Stroke	0G960500 - 0T800999	—	18-3719	18-2254	18-1562

① Long shaft only ③ Offshore only ⑤ 3 Jaw reverse clutch N.L.A. No longer available
 ② Standard rotation only ④ 6 Jaw reverse clutch ⑥ Pre-load pin, w/o driveshaft nut

APPLICATION CONTINUED ON NEXT PAGE

MERCURY OUTBOARD LOWER UNIT APPLICATIONS

Model	Serial Number	Drive Shaft	Pinion Nut	Propeller Shaft	Clutch
100 (4 cyl.)	B209468 - 0G760299	—	18-3719	—	18-2236 ⑤
100 (4 cyl.)	B209468 - 0G760299	—	18-3719	18-2254	18-1562 ④
100 (4 cyl.)	0G760300 & Up	—	18-3719	18-2254	18-1562
1150	2836019 - 2933900	—	18-3719	—	18-2236
1150	2933901 - 3525440	—	18-3719	—	18-2236
1150	3525441 - 4112634	—	18-3719	—	18-2236
1150	4112635 - 4855152	—	18-3719	—	18-2236
1150 / 115	4855153 - 5314655	—	18-3719	—	18-2236
115 (6 cyl.)	5314656 - 5600966	—	18-3719	—	18-2236
115 (6 cyl.)	5600967 - 6436122	—	18-3719	—	18-2236
115 (6 cyl.)	6436123 & Up	—	18-3719	—	18-2236
115 (4 cyl.)	C100000 - 0G760299	—	18-3719	—	18-2236 ⑤
115 (4 cyl.)	C100000 - 0G760299	—	18-3719	18-2254	18-1562 ④
115 (4 cyl.)	0G760300 & Up	—	18-3719	18-2254	18-1562
115 DFI	0T801000 & Up	—	18-3719	18-2254	18-1562
115 Four Stroke	0T178500 - 0T800999	—	18-3719	18-2254	18-1562
1250	2314956 - 2839368	—	18-3719	—	18-2236
125 (4 cyl.)	0D283222 - 0G760299	—	18-3719	—	18-2236 ⑤
125 (4 cyl.)	0D283222 - 0G760299	—	18-3719	18-2254	18-1562 ④
125 (4 cyl.)	0G760300 & Up	—	18-3719	18-2254	18-1562
1350	2839369 - 2940020	—	18-3719	—	18-2236
1350	2940021 - 3293233	—	18-3719	—	18-2236
1400	3293234 - 3502805	—	18-3719	—	18-2236
140	4865687 & Up	—	18-3719	—	18-2236
1500	3502806 - 4121434	—	18-3719	—	18-2236
1500	4121435 - 4865677	—	18-3719	—	18-2236
V-135	0A904646 - 0G437999	18-1737	18-3719	18-2239	—
V-135	0G438000 - 0T178499	18-1737	18-3719	18-2239 ②	—
V135 DFI	G590000 - 1B417701	18-1737	18-3719	18-2239	18-1565
V140	T178500 & Up	—	18-3719	18-2239	—
V-150 (Casting # 1647-6670C)	4868998 - 0A904645	—	18-3719	—	—
V-150 (Casting #1647-8675C)	4868998 - 0A904645	—	18-3719	18-2239	—
V-150	4868998 - 0A904645	18-1737	18-3719	18-2239	—
V-150	0A904646 - 0G437999	18-1737	18-3719	18-2239	—
V-150	0G438000 & Up	18-1737	18-3719	18-2239	18-1565
V-150 XR-4 (Casting #1655-9572C)	B242885 - 0D081999	—	18-3719	—	18-2236
V-150 XR-4 (Casting #1674-814247C)	B242885 - 0D081999	—	18-3719	—	18-2236
V-150 XR-6	D082000 - 0G303045	18-1737	18-3719	18-2239	18-2236
V-150 XR-6	0G438000 & Up	18-1737	18-3719	18-2239	18-1565
V-150XRI (EFI)	D082000-0G437999	18-1737	18-3719	— ②	18-2236 ②
V-150XRI (EFI)	0G438000 & Up	18-1737	18-3719	18-2239 ②	18-1565
V150 DFI	G590000 & Up	18-1737	18-3719	18-2239	—
V-175	4301235 - 5393736	— ⑥	18-3719	—	—
V-175	5393737 - 6618750	— ⑥	18-3719	18-2239	—
V-175	6618751 - 0G437999	18-1737	18-3719	18-2239	—
V-175	0G438000 & Up	18-1737	18-3719	18-2239	18-1565
V-175XRI (EFI)	D000750 - 0G437999	18-1737	18-3719	18-2239	—
V-175XRI (EFI)	0G438000 & Up	18-1737	18-3719	18-2239	18-1565
V-200	4839034 - 6625220	— ⑥	18-3719	18-2239	—
V-200	6625221 - 0G437999	18-1737	18-3719	18-2239	—
V-200	0G438000 & Up	18-1737	18-3719	18-2239	18-1565
V-200 (EFI)	C100861 - 0G437999	18-1737	18-3719	18-2239	—
V-200 (EFI)	0G438000 & Up	18-1737	18-3719	18-2239	18-1565
V-200 (2.5L)	C291520 - D081999	—	18-3719	18-2239 ②	—
V-200 DFI	0G438000 & Up	—	18-3719	—	18-1565
V-220	B117316 & Up	—	18-3719	18-2239	—
V-225	5628028 & Up	— ①	18-3719	18-2239	—
225	D280813 & Up	—	18-3719	—	—
HIGH PERFORMANCE MODELS					
2.4 EFI	B290010 & Up	—	18-3719	18-2260 ② ③	—
XR-2	B290314 - C276429	—	18-3719	18-2260 ②	—
MOD-VP	B290066 - C276379	—	18-3719	18-2260	—

- ① Long shaft only ③ Offshore only ⑤ 3 Jaw reverse clutch N.L.A. No longer available
 ② Standard rotation only ④ 6 Jaw reverse clutch ⑥ Pre-load pin, w/o driveshaft nut

PKG. OF 10



18-0202-9®
INSERT
 Replaces: 8227731
 Fits: Mercury/Mariner
 25-125hp Outboards



18-3751
SPANNER NUT
 Replaces: 79448
 For: V-6



18-2298
TAB WASHER
 Replaces: 14-18323, 14-17460



18-2299
TAB WASHER
 Replaces: 14-79447, 14-52833



**STAINLESS STEEL
 LOCKNUTS**

Part #	O.E. #	Thread Size	Std. Pkg.
*18-3720 ⑦	11-34932	3/8" - 24	1
*18-3721 ⑦	11-34933, 11-95702, 11-82671015, 11-46355, 11-33962, 11-29241, 11-24648, 11-22178, 11-21298	7/16" - 20	6
*18-3722 ⑦	11-35888, 11-20361, 11-8267089	1/4" - 28	5
*18-3723 ⑦	11-45592	5/16" - 24	1

*To order locknuts in packages of 5, add -9 to end of part number

® Priced per package

POWER TRIM HOSE
For all power trim equipped, inline engines except models with power trim pump mounted between the engine clamp brackets.

**18-3701
PROP NUT KIT**
Replaces: 11-52707A1, 11-52707A2, 11-52707Q1
—CONTAINS—

Part #	O.E. #	Description
18-3200 (2)	14-31210, 14-816629	Tab Washer
18-3700	11-52707	Prop Nut

**18-3702
PROP NUT KIT**
Replaces: 11-69578A1, T1, Q1
—CONTAINS—

Part #	O.E. #	Description
18-3204 (2)	14-76281	Tab Washer
18-3704	11-69578	Prop Nut

Part #	Replaces:	Description
18-2110	32-45327, 32-88005, 32-97153A1	Small Diameter 2 required per engine
18-2111	32-88006, 32-45959, 32-97154A1	Large Diameter 2 required per engine

**18-3700
PROP NUT**
Replaces: 11-52707, 11-52707A1, 11-52707Q1, 11-52707A2, 11-827614 F7040

**18-3704
PROP NUT**
Replaces: 11-69578

**18-3703
PROP NUT**
Replaces: 11-88228
For: 9.9-25 HP 1986-Up

**18-3714
BRASS CASTLE WASHER**
Replaces: 12-31211A2, 12-31211, 12-31211A3, 12-31211Q03
For: 135-275 HP (V6 2 cycle)

TAB WASHER/PROP NUT/PROP NUT KIT APPLICATION

HP	Beg. S/N	End. S/N	Tab Washer	Prop Nut	Prop Nut Kit	HP	Beg. S/N	End. S/N	Tab Washer	Prop Nut	Prop Nut Kit
9.9 ④	G760300	& UP	—	18-3703	—	80	2559001	& UP	18-3200	18-3700	18-3701
15 ④	G590000	& UP	—	18-3703	—	85	1460999	3493912	18-3200	—	—
18	5837437	& UP	—	18-3703	—	85	3493913	4831998	18-3200	18-3700	18-3701
20	6443973	& UP	—	18-3703	—	90	1766824	4845300	18-3200	—	—
25	6416713	& UP	—	18-3703	—	90	4845301	& UP	18-3200	18-3700	18-3701
35	— ③	—	18-3204	18-3704	18-3702	95	1869776	2318585	18-3200	—	—
40	— ③	—	18-3204	18-3704	18-3702	100	1464949	2484632	18-3200	—	—
50	— ③	—	18-3204	18-3704	18-3702	100	2484633	2836018	18-3200	18-3700	18-3701
60	— ③	—	18-3204	18-3704	18-3702	100	B209468	& UP	18-3200	18-3700	18-3701
65	1542745	2503990	18-3200	—	—	110	1870204	2314955	18-3200	—	—
65	2503991	3293183	18-3200	18-3700	18-3701	115	2836019	& UP	18-3200	18-3700	18-3701
70	1482212	1566239	18-3200	—	—	125	2314956	2536209	18-3200	—	—
70	— ③	A996141	18-3204	18-3704	18-3702	125	2536210	2839368	18-3200	18-3700	18-3701
70	A996142	& UP	18-3200	18-3700	18-3701	135	2839369	3293233	18-3200	18-3700	18-3701
75	6432901	& UP	18-3200	18-3700	18-3701	140	3293234	& UP	18-3200	18-3700	18-3701
80	1405637	1566239	18-3200	—	—	150(Inline)	3502806	& UP	18-3200	18-3700	18-3701
③ Fits most applications	④ 4-Stroke Bigfoot					V-6	All	—	18-3200	18-3700	18-3701

**18-4444
PROP WRENCH**
Replaces: 91-95830A1, 91-95830, 91-38277A1

**18-4446
PROP WRENCH KIT**
— CONTAINS —

Part #	Desc.	O.E. #	Qty.
18-3200	Tab Washer	14-31210, 14-816629	2
18-3700	Prop Nut	11-52707	1
18-4444	Prop Wrench	91-95830A1	1

**18-4459
PROP WRENCH**
Replaces: 91-821887A1, 91-859046Q4, 91-859046T4

① Items ending in "D" are Display Packaged - Regular number is Non-Display
② Priced per Package

439



**18-9075
SPACER**
Replaces: 23-888690
For: 2-Stroke: 115hp. - 300hp. (1993-Current)
4-Stroke: 115hp. - 225hp. (2002-Current)



**18-9076
COLLAR**
Replaces: 23-888690-1
For: 2-Stroke: 115hp. - 300hp. (1993-Current)
4-Stroke: 115hp. - 225hp. (2002-Current)



**18-9077
WAVE WASHER**
Replaces: 13-888363-2
For: 2-Stroke: 115hp. - 300hp. (1993-Current) 4-Stroke: 115hp. - 225hp. (2002-Current)



**18-9079
WAVE WASHER KIT**
Replaces:
Fits: Yamaha 2-stroke 115-300hp (1993 & Up); Yamaha 4-stroke 115-225hp (2002 & Up); Mercury 4-stroke 225 EFI S/N OT653945 & Up



**18-9078
STAINLESS STEEL WASHER**
Replaces: 12-855682-2
For: 2-Stroke: 115hp. - 300hp. (1993-Current)
4-Stroke: 115hp. - 225hp. (2002-Current)



18-4220 Display Package
THRUST WASHER
Part # Replaces
18-4220 12-13171, 12-77987, 12-8354671, 12-77987A1, 12-835467, 12-835467Q01
V-6 Outboards & Mercuriur Sterndrives
18-4221 13191A1,75282A1
4 & 6 Inline - 75-150 HP



**18-4233
THRUST WASHER**
Replaces: 73345, 73345A1, 12-92647M
35-70 HP



**18-9010
MOTOR FLUSHER**
Heavy Duty



**18-3607
RETAINER BRACKET**
Replaces: 893409
For: 200/225 4-Stroke Verado (S/N OT980000 & Up), 250/275 4-Stroke Verado (S/N OT801000 & Up)



**18-2700
STEERING CYLINDER SEAL KIT**
Replaces: 896173A01, 8M0045604
For: 200/225 4-Stroke Verado (S/N OT980000 & Up), 250/275 4-Stroke Verado (S/N OT801000 & Up)



**18-79989
TRAILERING STICKS**
Fits: Most outboards over 150hp with three ram intrigrel tilt/trim.

Zinc is for saltwater only applications.
Magnesium is for fresh water only applications.
Aluminum is for brackish water or salt water environments.



**18-6156A
18-6156M
ANODE KIT**
Verado 4 cyl. All Models



**18-6157A
18-6157M
ANODE KIT**
Replaces: 8M0058677
Verado 6 cyl. All Models



② **18-6241**
③ **18-6011**
① **18-6011A**
ANODE

Replaces:
31640, 31640A1, 97-31640Q4,
97-31640B4, 31640A4, 31640A2,
316404, 316403, 72436A1
Use on inline 3, 4 & 6 Cyl. V6



③ **18-6014**
① **18-6014A**
ANODE

Replaces:
46399A1, 822777A1, 822777Q1,
822777A4, 822777A3, 8227772,
822777, 46399A2
For use with 225 (3.0L Carb.) models



③ **18-6016**
③④ **18-60161**
③⑤ **18-60161-9**
① **18-6016A**
② **18-6244**
ANODE

Replaces:
76214, 97-76214Q5, 97-762145,
76214A5, 786214A2, 762142,
762142A1
200, 225, 250HP, V-155-V-200, & All Bravos



③ **18-6068**
ANODE
Replaces: 826134, 826134A1,
97-826134Q

① Aluminum ② Magnesium ③ Zinc
④ Standard package of 10 priced per piece ⑤ Standard package of 10 priced per package



③ **18-6249**
① **18-6249A**
ANODE
Replaces: 43396A2, 818298A1, Q1
For use on transom mount bracket:
175HP/150EFI/200EFI
(S/N OG303046 & Up)

① **18-6245D** 



18-6245
ANODE
MOUNTING BOLT
Replaces: 10-32470
For use with: 18-6011, 18-6014, 18-6016
7/16" X 1 3/4" Allen Head Cap Screw



18-2599
FACE SEAL
AND TOOL
Replaces: 26-816575A2



18-2742
SHIFT SHAFT BOOT
Replaces: 85552

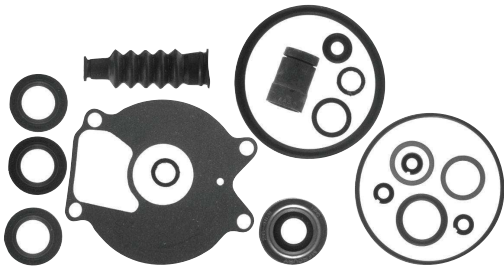

18-2624
LOWER UNIT SEAL KIT
Replaces: 26-85090A2

— CONTAINS —

Part #	Desc.	O.E.#	Qty.
18-0579	Oil Seal	26-41131	1
18-0580	Oil Seal	26-41132	1
18-0586	Seal	26-99325	2
18-7419	O-Ring	25-69202	1
18-2562	Gear Hsg to Face Plate Gasket	27-99326-1	1
18-2945	Washer	12-20260	2
18-2742	Boot	85552	1
18-2560	Washer	12-86645	2
18-7135	O-Ring	25-35276	1
18-7188	O-Ring	25-805726	2
18-7956	O-Ring	25-85549	1
18-7100	O-Ring	25-85594	1

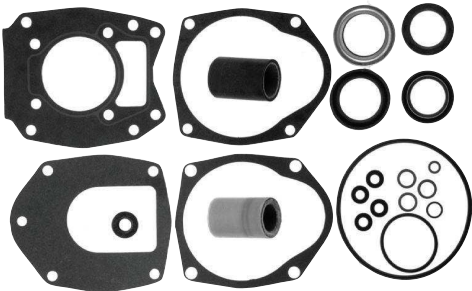

18-2626
LOWER UNIT SEAL KIT
Replaces: 26-43035A4, 26-43034A1, 26-43034A2, 26-43034A3

— CONTAINS —

Part #	Desc.	O.E.#	Qty.
18-0522	Oil Seal	26-43036	1
18-0583	Oil Seal	26-43035	1
18-2002	Oil Seal	26-30550, 26-76868	1
18-2053	Oil Seal	26-70081	1
18-2054	Oil Seal	26-8164641	1
18-2563	Face Plate to Water Pump Cover Gasket	27-43034-1	1
18-2564	Water Pump Base to Face Plate Gasket	27-43033-1	1
18-2565	Water Pump Base to Gear Housing Gasket	27-43047-2	1
18-2566	Face Plate to Water Pump Cover Gasket	27-817277	1
18-2945	Washer	12-19183	3
18-4261	Washer	19643	1
18-7188	O-Ring	25-805726	1
18-7198	O-Ring	25-45710	1

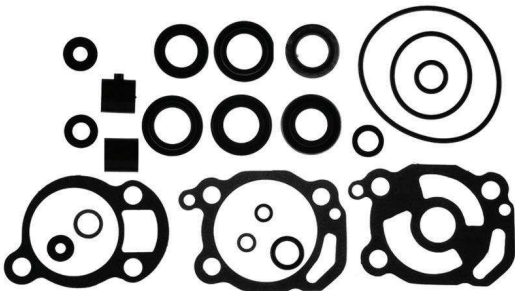

18-2627
LOWER UNIT SEAL KIT
Replaces: 26-66303A1

— CONTAINS —

Part #	Desc.	O.E.#	Qty.
18-0595	Seal	26-66303	2
18-2004	Seal, Water Pump Base	26-20070	2
18-2006	Seal, Water Pump Base	26-897154	1
18-2019	Seal	26-26805	1
18-2827	Upper Face Plate to Water Pump Gasket	27-39623	1
18-2828	Lower Water Pump Base to Face Gasket	27-39625	1
18-2945	Washer	12-20260	1
18-4261	Washer	12-20262	1
18-7120	O-Ring	25-38933	1
18-7163	O-Ring	25-33465	1
18-7164	O-Ring	25-33466	1
18-7180	O-Ring	25-26802	2

① Aluminum

③ Zinc

— CONTAINS —

Part #	Desc.	O.E.#	Qty.
18-0584	Oil Seal, Prop Shaft	26-66022	1
18-2010	Seal, Wtr Pump Base	26-897153	1
18-2945	Washer, Fill Screw	12-20260	1
18-4261	Washer, Fill Screw	12-20262	1
18-7116	O-Ring	25-62704	1
18-7120	O-Ring	25-38933	1
18-7156	O-Ring	25-29439	1
18-7168	O-Ring	25-48171	1
18-7171	O-Ring	25-30529	1
18-7180	O-Ring	25-26802	1
18-8308	Seal, Shift Shaft	26-30696	1
18-8310	Seal, Water Pump Base	26-30900T	1

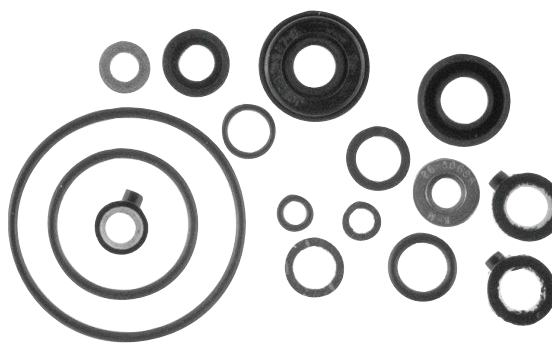

18-2628
LOWER UNIT SEAL KIT
 Replaces: 26-77066A1

— CONTAINS —

Part #	Desc.	O.E.#	Qty.
18-2006	Seal	26-897154	2
18-2560	Washer	12-86645	2
18-2562	Gear Housing to Face Plate Gasket	27-99326-1	1
18-2742	Boot	85552	1
18-2945	Washer	12-20260	2
18-7135	O-Ring	25-35276	1
18-7419	O-Ring	25-69202	1
18-7956	O-Ring	25-85549	1
18-7100	O-Ring	25-85594	1
18-8348	Slinger	25-86203	1



18-2629
LOWER UNIT SEAL KIT
 Replaces: 26-85090A1

— CONTAINS —

Part #	Desc.	O.E.#	Qty.
18-0500	Seal	26-817472	1
18-0622	Gasket, Lower Wear Plate	27-19701	1
18-2051	Seal	26-69188	1
18-2052	Seal	26-69189	1
18-2945	Washer	12-19183	3
18-7168	O-Ring	25-48171	2
18-7173	O-Ring	25-30224	1
18-7950	O-Ring	25-45258	1

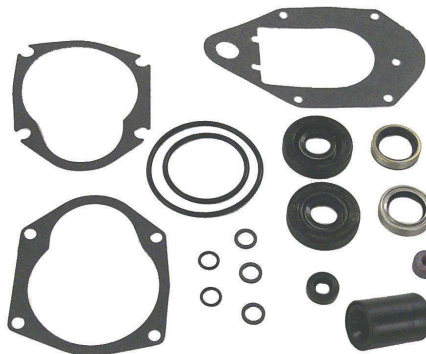

18-2635
LOWER UNIT SEAL KIT
 Replaces: 26-814669A2

— CONTAINS —

Part #	Desc.	O.E.#	Qty.
18-2563	Face Plate to Water Pump Gasket	27-43034-1	1
18-2564	Water Pump Base to Face Plate Gasket	22-43033-1	1
18-2945	Drain Screw Gasket	12-19183,12-20260	2
18-2599	Face Seal & Tool	26-816575A2	1
18-2014	Oil Seal	26-89238	1
18-2013	Oil Seal	26-16977	1
18-2054	Oil Seal	26-8164641	1
18-7159	O-Ring	25-31534	1
18-7176	O-Ring	25-90011	1
18-7420	O-Ring	25-21836	2
18-7440-1	O-Ring	25-36318	2

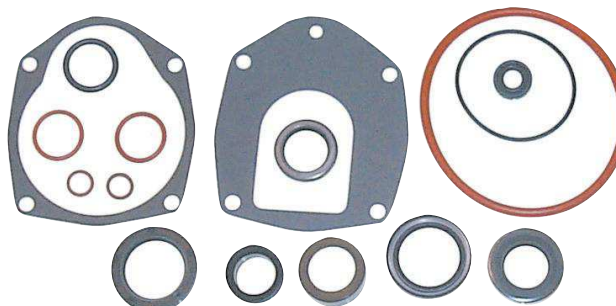

18-2642
LOWER UNIT SEAL KIT
 Replaces: 26-816575A5

APPLICATION BEGINS ON PAGE 445



18-2646-1
LOWER UNIT SEAL KIT
 Replaces: 26-816575A3, 26-816575A1

--- CONTAINS ---			
Part #	Desc.	O.E.#	Qty.
18-2599	Face Seal and Tool	26-818575A2	1
18-2564	Water Pump Base To Face Plate Gasket	27-43033-1	1
18-2566	Face Plate to Water Pump Cover Gasket	27-817277	1
18-2945	Sealing Washer	12-19183	1
18-2944	Seal	26-45577	1
18-2002	Oil Seal	26-30550, 26-76868	1
18-2009	Oil Seal	26-892361	1
18-2013	Oil Seal	26-16977	1
18-2014	Oil Seal	26-89238	1
18-2056	Oil Seal	26-965031	2
18-2076	Oil Seal	26-12224	1
18-2077	Oil Seal	26-14077	1
18-7159	O-Ring	25-31534	1
18-7168	O-Ring	25-48171	2
18-7176	O-Ring	25-90011	1
18-7420	O-Ring	25-21836	2
18-7440-1	O-Ring	25-36318	2
18-2056	Oil Seal	26-66302	2
18-7413	O-Ring	25-62702	2
18-2009	Oil Seal	26-892361	1
18-2430	Drain Screw Casket	26-830749	1



18-2653
LOWER UNIT SEAL KIT
 Replaces: 26-55682A1

--- CONTAINS ---			
Part #	Desc.	O.E.#	Qty.
18-3110	Grommet	26-38970	1
18-2002	Oil Seal	26-30550, 26-76868	2
18-2007	Oil Seal	26-94038	1
18-2009	Oil Seal	26-892361	1
18-2013	Oil Seal	26-16977	1
18-2014	Oil Seal	26-89238	1
18-2048	Oil Seal	26-24590	1
18-2050	Oil Seal	26-55682	1
18-2053	Oil Seal	26-70081	1
18-2826	Water Pump Base to Gear Housing Gasket	27-85610-1	1
18-2914	Water Pump Gasket	27-85608-1	1
18-2915	Water Pump Gasket	27-85609-1	1
18-2948	Rubber Washer	12-49221-1	1
18-7153	O-Ring	25-25439	1
18-7157	O-Ring	25-29976	1
18-7158	O-Ring	25-30613	1
18-7159	O-Ring	25-31534	1
18-7161	O-Ring	25-32546	1
18-7162	O-Ring	25-33145	1
18-7173	O-Ring	25-30224	1
18-2801	Water Pump Gasket	27-32438	1
18-7426	O-Ring	25-30271	1
18-2945	Drain Screw Gasket	12-20260, 12-19183	2

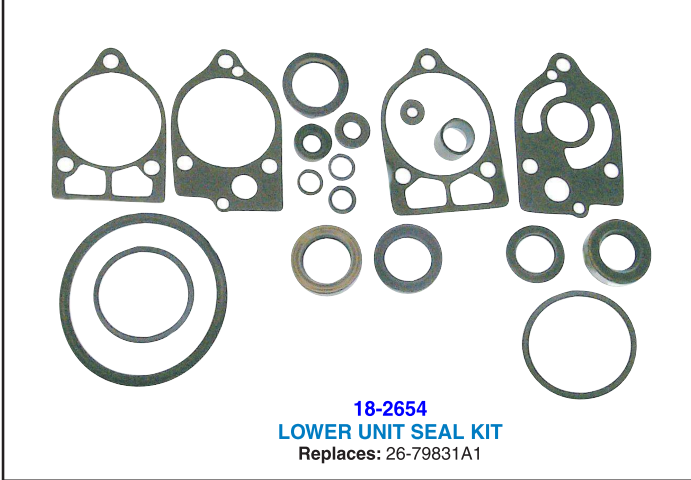

18-2654
LOWER UNIT SEAL KIT
 Replaces: 26-79831A1

--- CONTAINS ---			
Part #	Desc.	O.E.#	Qty.
18-2008	Oil Seal	26-56788	1
18-2011	Oil Seal	26-90562	1
18-2048	Oil Seal	26-24590	1
18-2051	Oil Seal	26-69188	1
18-2052	Oil Seal	26-69189	1
18-2054	Oil Seal	26-816464	1
18-2055	Oil Seal	26-79831	1
18-2823	Lower Water Pump Base to Face Plate Gasket	27-32769	1
18-2824	Upper Face Plate to Pump Body Gasket	27-19551	1
18-2825	Water Pump Base Gasket	27-32770	1
18-2841	Water Pump Base Gasket	27-19552, 27-77417	1
18-2948	Rubber Washer	12-49221-1	1
18-7153	O-Ring	25-25439	1
18-7155	O-Ring	25-26855	1
18-7160	O-Ring	25-31986	1
18-7115	O-Ring	25-26722	1
18-2945	Drain Screw Gasket	12-20260, 12-19183	2

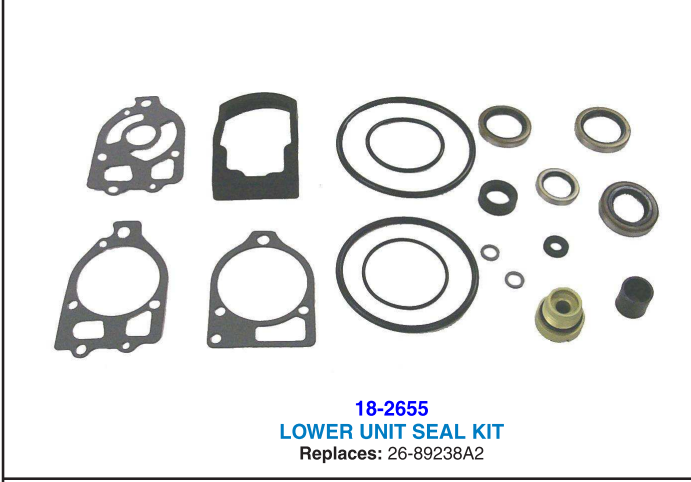

18-2655
LOWER UNIT SEAL KIT
 Replaces: 26-89238A2

--- CONTAINS ---			
Part #	Desc.	O.E.#	Qty.
18-2155	Bushing Gasket	23-77631A2	1
18-2919	Gasket	27-42631-1	1
18-2002	Oil Seal	26-30550, 26-76868	2
18-2013	Oil Seal	26-16977	1
18-2014	Oil Seal	26-89238	1
18-2914	Water Pump Gasket	27-85608-1	1
18-2915	Water Pump Gasket	27-85609-1	1
18-3110	Bushing	26-38970	1
18-7159	O-Ring	25-31534	1
18-7176	O-Ring	25-90011	1
18-7157	O-Ring	25-29976	1
18-7153	O-Ring	25-25439	1
18-2009	Oil Seal	26-89236	1
18-7426	O-Ring	25-30271	1
18-2945	Drain Screw Gasket	12-20260, 12-19183	2

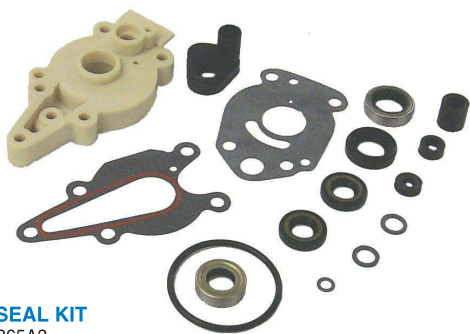

18-2697-1
LOWER UNIT SEAL KIT
 Replaces: 26-41365A3

— CONTAINS —

Part #	Desc.	O.E.#	Qty.
18-0581	Oil Seal	26-413651	2
18-0584	Oil Seal	26-66022	1
18-0585	Oil Seal	26-821928	1
18-0586	Oil Seal	26-99325	1
18-2728	Water Tube Seal	26-42102-1	1
18-2945	Washer	12-19183	2
18-3149-2	Water Pump Base	46-42040A5	1
18-4261	Washer	19643	1
18-7162	O-Ring	25-33145	1



18-74501
GEAR HOUSING SEAL KIT

Replaces: 27-99049M
 Fits: Mariner 9.9C & 15C models

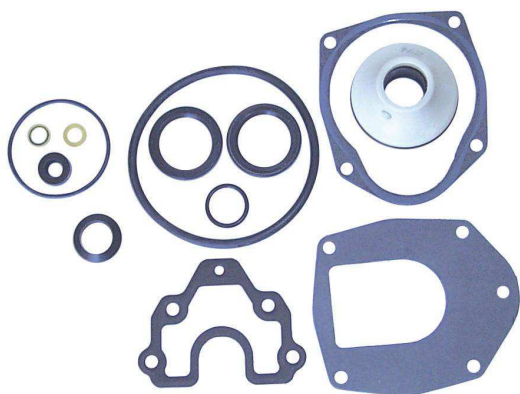

18-2725
LOWER UNIT SEAL KIT
 Replaces: 26-830749A01

For: 135/150/175 4-Stroke Verado (S/N 1B227000 & Up), 200/225 4-Stroke Verado (S/N OT980000 & Up), 250/275 4-Stroke Verado (S/N OT801000 & Up)

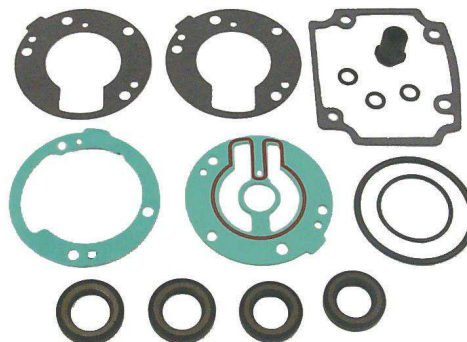

18-2785
LOWER UNIT SEAL KIT
 Replaces: 27-41899M

— CONTAINS —

Part #	Desc.	O.E.#	Qty.
18-4698	Drain or Fill Washer Gasket	27-81987M	3
18-0554	Oil Seal	26-84813M	1
18-0296	Oil Seal	26-854017M	2

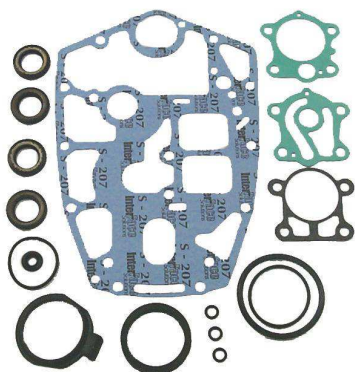

18-2787
LOWER UNIT SEAL KIT
 Replaces: 27-92648M

— CONTAINS —

Part #	Desc.	O.E.#	Qty.
18-4698	Drain or Fill Washer Gasket	27-81987M	3
18-0296	Oil Seal	26-854017M	2
18-0297	Oil Seal	26-82234M	2
18-0298	O-Ring	25-82275M	1
18-0299	O-Ring	25-82289M	1
18-0292	Wear Plate to Pump Housing Gasket	27-81417M	1
18-0267	Oil Seal	26-82257M	1
18-0294	Wear Plate to Pump Base Gasket	27-81421M	1



18-8382
LOWER UNIT SEAL KIT

Replaces: 26-816575A4
 For: 200 HP (T801000 & UP), 200 HP OPTIMAX DFI (G438000 & UP), 225 HP EFI (G438000 & UP), 225 HP OPTIMAX DFI (G590000-G960499), 250 HP EFI (G438000 & UP), MODELS WITH "C-3 CASTING": 200 HP OPTIMAX DFI (G386496-G437999), 225 HP (D280813-G437999), 225 HP EFI (G129222-G437999), 250 HP EFI (G129222-G437999)

APPLICATION ON NEXT PAGE

GEAR HOUSING SEAL KIT APPLICATION

HP	Beg. Serial #	End. Serial #	Part #	HP	Beg. Serial #	End. Serial #	Part #
4 (1cyl)	5595532	A809600	18-2628	60 (3 cyl)	6428681	D000749	18-2654
4.5 (1 cyl)	4107220	& UP	18-2628	60 (3 cyl)			
6	A197112	& UP	18-2697-1	non-Bigfoot	D000750	& UP	18-2635
7.5	4851693	& UP	18-2628	60 (3 cyl)			
8	A197112	& UP	18-2697-1	Bigfoot	D000750	& UP	18-2626
8 Bodensee (4-stroke)	G760300	T178499	18-2697-1	60 (4-stroke)			
9.8	4839254	& UP	18-2628	Bigfoot	T178500	& UP	18-2626
9.9	A197112	& UP	18-2697-1	60 (4-stroke)			
9.9 (4-stroke) non-Bigfoot	G760300	& UP	18-2697-1	non-Bigfoot	T178500	& UP	18-2635
9.9 (4-stroke) Bigfoot	G760300	& UP	18-2624	60 Seapro/ Marathon/ Big Foot (3 cyl)	D000750	& UP	18-2626
Seapro/XR10	D038000	& UP	18-2697-1	70	4571652	A996141	18-2654
15	A197112	& UP	18-2697-1	70	A996142	& UP	18-2626
15 (4-stroke) non-Bigfoot	G760300	& UP	18-2697-1	75 (4 cyl)	6432901	& UP	18-2653
15 (4-stroke) Bigfoot	G760300	& UP	18-2624	75 (3 cyl)	A996142	& UP	18-2626
Magnum/ Marathon 15XD/ Super 15	ALL		18-2624	75 (4-stroke)	G960500	& UP	18-2626
18	5837437	6443972	18-2629	80 (4 cyl)	4831999	6432900	18-2653
18	6443973	& UP	18-2624	80 (3 cyl)	A966142	& UP	18-2626
20	4709593	6443972	18-2627	90 (6 cyl)	4845301	& UP	18-2653
20	6443973	& UP	18-2624	90 (3 cyl)	A996142	& UP	18-2626
25	5705532	6443972	18-2629	90 (4-stroke)	G960500	& UP	18-2626
25	6443973	& UP	18-2624	100 (4 cyl)	B209468	& UP	18-2626
25 Lightning (3 cyl)	E268781	& UP	18-2624	115 (6 cyl)	4855153	B209467	18-2653
30 (4-stroke) (3 cyl) Bigfoot	G760300	& UP	18-2626	115 (4 cyl)	C100000	& UP	18-2626
35	6445653	& UP	18-2654	115EFI (4-stroke)	T178500	& UP	18-2626
40 (2 cyl)	4860103	G053313	18-2654	125 (4 cyl)	D283222	& UP	18-2626
40 (4 cyl)	C159200	& UP	18-2654	V-135	A904646	& UP	18-2655
40 (4-stroke) (3 cyl) Bigfoot	G760300	& UP	18-2626	V-135 DFI	G590000	& UP	18-2655
45	5531630	& UP	18-2654	140 (6 cyl)	4865678	& UP	18-2653
50 (4 cyl)	4357640	& UP	18-2654	V-150	4868648	A904645	18-2653
50 (3 cyl)	6428681	D000749	18-2654	V-150 (carb)	A904646	& UP	18-2655
50 (3 cyl)	D000750	G589999	18-2635	V-150 XR4, XR6, MAGII, III	B242885	& UP	18-2655
50 (4-stroke) (4 cyl) Bigfoot	G760300	& UP	18-2626	V-150 EFI	D820000	& UP	18-2655
50 (4-stroke) Bigfoot	G231123	& UP	18-2626	V-150 DFI	G590000	& UP	18-2655
50 (4-stroke) non-Bigfoot	T178500	& UP	18-2635	V-175	4301235	6618750	18-2653
55 (3 cyl)	D000750	& UP	18-2635	V-175 (carb)	6618751	& UP	18-2655
				V-175 XRI(EFI)	D000750	& UP	18-2655
				V-200	4839034	6625220	18-2653
				V-200 (carb)	6625221	& UP	18-2655
				V-200 XRI(EFI)	C100861	& UP	18-2655
				V-200 DFI (3.0L)	G386496	G960499	18-2642
				V-220	B117316	& UP	18-2655
				V-225	5628028	& UP	18-2653
				V-225	D280813	& UP	18-2646-1
				V-225/225 DFI	G386496	& UP	18-2642
				V-250	G386496	& UP	18-2642

MARINER LOWER UNIT SEAL KITS (Japanese Models)

Model	Serial #	O.E. Kit #	Part #
20C	(6A9-) ALL	27-41899M/27-95660M	18-2785
25C	(695-) ALL	27-41899M/27-95660M	18-2785
30A	(689-) ALL	27-41899M/27-95660M	18-2785
W48	(670-) ALL	27-92648M	18-2787
55/W55	(663-) ALL	27-92648M	18-2787
60	(675-) ALL (6F0-) ALL	27-92648M	18-2787

OIL SEALS



Part #	O.E. #	Shaft Size (in.)	Dimensions (in.)	
			O.D.	Width
18-0531	26-72785	0.790	1.880	0.248
18-0537	26-85107	1.020	1.507	0.251
18-0554	26-84813M	0.787	1.339	0.260
18-0560 ③	26-888483	1.250	1.690	0.256
18-0564 ④	26-888483	1.250	1.690	0.256
18-0579	26-41131	1.141	1.313	0.344
18-0580	26-41132	0.750	1.250	0.312
18-0581	26-413651	0.500	0.984	0.200
18-0583	26-43035	1.063	1.496	0.197
18-0584	26-66022	0.056	1.000	0.312
18-0585	26-821928	0.687	1.125	0.312
18-0586	26-99325	0.675	1.125	0.250
18-0595	26-66303	0.688	1.125	0.250
18-2002	26-76868, 26-30550	1.188	1.692	0.250
18-2004	26-20070	0.625	1.000	0.250
18-2006	26-897154	0.625	1.125	0.312
18-2008	26-56788	0.875	1.250	0.375
18-2010	26-897153	0.437	0.875	0.250
18-2053	26-70081	1.185	1.754	0.360
18-8308	26-30696	0.297	0.625	0.156
18-8310	26-30900T	0.453	0.828	0.172
18-8347	26-8164641	0.375	0.750	0.243

Part #	O.E. #	Shaft Size (in.)	Dimensions (in.)	
			O.D.	Width
18-0172	26-97530	0.845	1.500	0.315
18-0267	26-82257M	0.354	0.748	0.197
18-0296	26-854017M	0.866	1.417	0.236
18-0297	26-82234M	0.906	1.457	0.236
18-0515	26-30530	0.540	1.004	0.303
18-0516	26-30913	0.500	0.839	0.187
18-0517	26-32911	1.100	1.260	0.127
18-0518 ②	26-34217	0.282	0.394	0.083
18-0519	26-14240	3.792	4.536	0.482
18-0522	26-43036	1.045	1.474	0.187
18-0523	26-43993	1.640	2.132	0.282
18-0525	26-45587	0.390	0.628	0.124
18-0526	26-48443	0.750	1.379	0.256
18-0527	26-56397	0.750	1.127	0.343
18-0529	26-62818	1.640	2.256	0.319

① Line Cutter Seal ② Pkg. of 4 ③ Metal ④ Rubber

POWERHEAD SEALS APPLICATION

HP	Cyl.	Beginning Serial No.	Ending Serial No.	Upper Crankshaft	Qty.	Lower Crankshaft	Qty.
3.5	1	6202173	UP	—	—	18-0527	1
3.6	1	5404657	UP	—	—	18-0527	1
4	1	2771622	4107219	—	—	18-0527	1
4	1	5589202	UP	18-0515	1	—	—
4.5	1	4107220	UP	—	—	18-0527	1
7.5/9.8/110	2	2810637	3274633	—	—	18-0527	1
10/15/20/25	2	1290910	1499331	—	—	18-2013	1
20	2	1558310	2031773	—	—	18-2013	2
20	2	2031774	2827677	—	—	18-2013	2
18,20,25XD	2	6443973	UP	—	1	18-0537	1
20 JET	2	G053314	UP	—	1	18-0537	1
30	2	1271885	1356947	18-2016	1	18-2016	1
30JET	2	C159200	UP	18-2016	1	18-2016 ①	2
MK 35 A	2	1217222	1271884	18-2016	1	18-2016	1
35	2	1356948	1571113	18-2016	1	18-2016	1
35	2	1571114	2874703	—	—	18-2016 (lower)	1
35	2	6445653	UP	18-2016	1	18-2016	2
40	4	1279685	2874703	18-2016	1	18-2016	1
40	2	2874704	3336257	18-2016	1	18-2016	2
40	2	3336258	4117709	18-2016	1	18-2016	1
40	2	4117710	5556229	18-2016	1	18-2016	1
40	2	5556230	6445653	18-2016	1	18-2016	2
40	4	C159200	UP	18-2016	1	18-2016 ①	2
45	4	1476510	1531568	18-2016	1	18-2016	1
45	4	5531630	UP	18-2016	1	18-2016	2
45 JET	3	ALL	—	—	—	18-2016 (inner)	1
50	4	1421113	2858813	18-2016	1	18-2016 (inner)	1
50	4	2855514	UP	18-2016	1	18-2016	2
50/60	3	6428681	D000750	18-2016	1	18-2016	2
50/55/60	3	D000750	UP	—	—	18-2016 (inner)	1
60	6	1303411	1542744	18-2016	1	18-2016	1
65	4	1542745	2803561	18-2016	1	18-2016 (inner)	1
65	4	2803562	3293183	18-2016	1	18-2016	2
65	3	3293184	3547986	18-2016	1	18-2016	2
65	3	3547987	4571651	18-2016	1	18-2016	2
65 JET	3	D283222	UP	18-0523	1	18-2016	1

① Fits most models

POWERHEAD SEALS APPLICATION

HP	Cyl.	Beginning Serial No.	Ending Serial No.	Upper Crankshaft	Qty.	Lower Crankshaft	Qty.
70	6	1296411	1566239	18-2016	1	18-2016 (inner)	1
70	3	4571652	6428680	18-2016	1	18-2016	2
70	3	A996142	UP	18-0523	1	18-2016	1
75	4	6432901	A996141	18-2016	1	18-2016	2
75	3	A996142	D283221	18-0523	1	18-2016	1
75	3	D283222	UP	18-0523	1	18-2016	1
80	6	1335465	1566239	18-2016	1	18-2016	1
80	4	2559001	4831998	18-2016	1	18-2016	2
80	4	4831999	UP	18-2016	1	18-2016	2
80	3	A996142	UP	18-0523	1	18-2016	1
80 JET	4	D283222	UP	18-0523	1	18-2016	1
85	6	1460999	1766823	18-2016	1	18-2016	1
85	4	3493913	4831998	18-2016	1	18-2016	2
90	6	1766824	1869775	18-2016	1	18-2016 (outer)	1
90	6	4845301	A996141	18-2016	1	18-2016	2
90	3	A996142	D283221	18-0523	1	18-2016	1
90	3	D283221	UP	18-0523	1	18-2016	1
95	6	1869776	2318585	18-2016	1	18-2016 (inner)	1
100	6	1464949	2836018	18-2016	1	18-2016	1
100BP	6	2641855	3253111	18-2016	1	18-2016	2
100	4	B209468	D283221	18-0523	1	18-2016	1
100	4	D283222	UP	18-0523	1	18-2016	1
105JET	V-6	D082000	UP	18-2016	1	18-2016	2
110	6	1870204	2314955	18-2016	1	18-2016	1
115	6	2836019	3525440	18-2016	1	18-2016	2
115	6	3525441	C100000	18-2016	1	18-2016	2
125	6	2314956	3253111	18-2016	1	18-2016 (inner)	1
135	6	2839369	3293233	18-2016	1	18-2016	2
135	V-6	A904646	UP	18-2016	1	18-2016	2
140	6	3293234	UP	18-2016	1	18-2016	2
140JET	V-6	D082000	UP	18-2016	1	18-2016	2
150	6	3502806	5327662	18-2016	1	18-2016	2
150	V-6	4868998	6042945	18-2016	1	18-2016	2
150	V-6	6042946	UP	18-2016	1	18-2016	2
175	V-6	4301235	5875203	18-2016	1	18-2016	2
175	V-6	5875204	6618751	18-2016	1	18-2016	2
175	V-6	6618751	UP	18-2016	1	18-2016	2
200	V-6	4839034	5875303	18-2016	1	18-2016	2
200	V-6	5875303	6073191	18-2016	1	18-2016	2
200	V-6	6073192	UP	18-2016	1	18-2016	2
220	V-6	B117316	UP	18-2016	1	18-2016	2
225	V-6	5628028	UP	18-2016	1	18-2016	2

① Fits most models

LOWER UNIT SEALS APPLICATION

HP	Beginning Serial No.	Ending Serial No.	Prop Shaft Inner/Outer	Water Pump Base Upper/Lower	Water Pump Housing	Shift Shaft
3.5/3.6	5404657	UP	-	18-2010	18-0516	-
3.9	1655013	2498135	18-0515	-	18-0516	-
4	2498136	5589201	18-0515	-	18-0516	-
4	5589202	5595531	-	18-2010	18-0516	-
4/4.5	5589203	A809601	-	18-2010	18-0516	-
6	1408611	2529894	18-0515	-	18-0516	-
7.5	2529895	3801457	18-0515	-	18-0516	-
7.5	3801458	5206549	-	-	18-0516	-
7.5	5206550	UP	-	18-2010	18-0516	-
9.8	1470349	3795657	18-0515	-	18-0516	-
9.8	3795658	5206549	-	-	18-0516	-
9.8	5206550	UP	-	18-2010	18-0516	-
18	5837437	6443972	-	18-2006/18-2006	-	-
20	1558310	1866494	18-2019/18-2019	18-2006	18-2004	-
20	1866495	6443972	18-2019/18-2019	18-2004/18-2006	18-2004	-
25	5705532	6443972	-	18-2006/18-2006	-	-
30	1271885	1356947	18-2011	18-2011	18-2015	18-2009
30	G055314	UP	18-2051/18-2052	-	-	-
MK 35A	1217222	1271884	18-2011	18-2011	18-2015	18-2009
35	1356948	1448139	18-2011	18-2011	18-2015	18-2009
35	1571114	1960826	18-2011	18-2011	18-2017	18-2009
35	1960827	2874703	18-2011/18-2015	18-2011/18-2055	18-2017	18-2009
35	6445653	UP	18-2051/18-2052	18-2011/18-2055	-	18-2054
40	1279685	2874703	18-2011	18-2011	18-2015	18-2009
40	2874704	3336257	18-2008	18-2011/18-2055	18-2017	18-2009
40	3336258	4117709	18-2008	18-2011/18-2055	18-2017	18-2048
40	4117710	4860102	18-2051/18-2052	18-2011/18-2055	-	18-2009/18-2048

② .438 ID ONLY

LOWER UNIT SEALS APPLICATION (Cont.)

HP	Beginning Serial No.	Ending Serial No.	Prop Shaft Inner/Outer	Water Pump Base Upper/Lower	Water Pump Housing	Shift Shaft
40	4860103	6445652	18-2051/18-2052	18-2011/18-2055	-	18-2054
40 4cyl	C159200	G053313	18-2051/18-2052	18-2011/18-2055	-	18-2054
40 2cyl	G055314	UP	18-2051/18-2052	-	-	-
45	1476510	1531568	18-2011	18-2011	18-2017	18-2009
45 4cyl	5531630	UP	18-2051/18-2052	18-2011/18-2055	-	18-2054
50	1421113	1639472	18-2011	18-2011	18-2017	18-2009
50	1639473	1770178	18-2011	18-2011	18-2017	18-2009
50	1770179	2305100	18-2011/18-2015	18-2011/18-2055	18-2017	18-2009
50	2305101	2858813	18-2011/18-2015	18-2011/18-2055	18-2017	18-2048
50	2858814	4140999	18-2008	18-2011/18-2055	18-2017	18-2009/18-2048
50	4141000	4962055	18-2051/18-2052	18-2011/18-2055	-	18-2009/18-2048
50	4962056	5531630	18-2051/18-2052	18-2011/18-2055	-	18-2054
50 3cyl	6428681	D000750	18-2051/18-2052	18-2011/18-2055	-	18-2054
50/55/60 3 cyl	D000751	UP	18-2051/18-2052	-	-	18-2054
60	1303411	1542744	-	18-2011	18-2015	-
60	6428681	D000750	18-2051/18-2052	18-2011/18-2055	-	18-2054
65	1542745	2874263	18-2002/18-2002	18-2007	18-2013	18-2009
65	2874263	3293183	18-2002/18-2002	18-2007/18-2050	18-2013	18-2009/18-2048
65 3cyl	3293184	4136684	18-2008	18-2011/18-2055	18-2017	18-2009/18-2048
65 3cyl	4136685	4571651	18-2051/18-2052	18-2011/18-2055	18-2017	18-2009/18-2048
70	1296411	1413610	18-2011	-	18-2015	-
70	1413611	1566239	18-2002/18-2002	18-2007	18-2013	18-2009
70 3cyl	4571652	4977156	18-2051/18-2052	18-2011/18-2055	-	18-2009/18-2048
70 3cyl	4977157	5579016	18-2051/18-2052	18-2011/18-2055	-	18-2054
70 3cyl	5579017	A996142	18-2051/18-2052	18-2011/18-2055	-	18-2009
70/75 3cyl	A996142	UP	18-2002/18-2053	18-0522 (lower)	-	-
75 4cyl	6432901	A996142	18-2002/18-2053	18-2013/18-2007	-	18-2054
80	1335465	1398629	18-2002/18-2002	18-2007	18-2013	18-2009
80	1398630	1566239	18-2002/18-2002	18-2007	18-2013	18-2009
80 4cyl	2559001	3144218	18-2002/18-2002	18-2013/18-2007	18-2013	18-2009/18-2048
80 4cyl	3144219	4831998	18-2002/18-2002	18-2050/18-2007	18-2013	18-2009/18-2048
80 4cyl	4831999	5582561	18-2002/18-2002	18-2013/18-2007	-	18-2054
80 4cyl	5582562	A996142	18-2002/18-2053	18-2013/18-2007	-	18-2054
80 3cyl	A996142	UP	18-2002/18-2053	18-0522 (lower)	-	-
85	1460999	1766823	18-2002/18-2002	18-2007	18-2013	18-2009
85 4cyl	3493913	4590511	18-2002/18-2002	18-2050/18-2007	-	18-2009/18-2048
85 4cyl	4590512	4831998	18-2002/18-2002	18-2013/18-2007	-	18-2009/18-2048
90	1766824	1869775	18-2002/18-2002	18-2013/18-2007	18-2013	18-2009
90	4845301	5594656	18-2002/18-2002	18-2013/18-2007	-	18-2054
90	5594657	A996142	18-2002/18-2053	18-2013/18-2007	-	18-2054
90 3cyl	A996142	UP	18-2002/18-2053	18-0522 (lower)	-	-
95	1869776	2318585	18-2002/18-2002	18-2013/18-2007	18-2013	18-2009/18-2048
100,100SS	1464949	2836018	18-2002/18-2002	18-2013/18-2007	18-2013	18-2009
100BP	2399698	2641854	18-2002/18-2002	18-2013/18-2007	18-2013	18-2009/18-2048
100 4cyl	B209468	UP	18-2002/18-2053	18-0522 (lower)	-	-
110	1870204	2314955	18-2002/18-2002	18-2013/18-2007	18-2013	18-2009/18-2048
115	2836019	3525440	18-2002/18-2002	18-2013/18-2007	18-2013	18-2009/18-2048
115	3525440	4112634	18-2002/18-2002	18-2013/18-2007	-	18-2009/18-2048
115	4112635	4855152	18-2002/18-2002	18-2013/18-2007	-	18-2009/18-2048
115	4855153	5600966	18-2002/18-2002	18-2013/18-2007	-	18-2054
115	5600967	C100000	18-2002/18-2053	18-2013/18-2007	-	18-2054
115 4cyl	C100000	UP	18-2002/18-2053	18-0522 (lower)	-	-
125	2314956	2839368	18-2002/18-2002	18-2013/18-2007	18-2013	18-2009
135	2839369	3293233	18-2002/18-2002	18-2013/18-2007	18-2013	18-2009
140	3293234	3502805	18-2002/18-2002	18-2013/18-2007	18-2013	18-2009/18-2048
140	4865678	UP	18-2002/18-2002	18-2013/18-2007	-	18-2054
150	3502806	4121434	18-2002/18-2002	18-2013/18-2007	-	18-2009/18-2048
150	4121434	5327662	18-2002/18-2002	18-2013/18-2007	-	18-2009/18-2048

V-6'S

150/150XR2	4868998	5432021	18-2002/18-2002	18-2013/18-2014	-	18-2054
150/150XRS	5432021	A904646	18-2002/18-2002	18-2013/18-2014	-	18-2054
135/150/XR2	A904646	UP	18-2002/18-2002	18-2013/18-2014	-	18-2054
175	4301235	6618750	18-2002/18-2002	18-2013/18-2014	-	18-2054
175	6618751	UP	18-2002/18-2002	18-2013/18-2014	-	18-2054
200	4839034	6073191	18-2002/18-2002	18-2013/18-2014	-	18-2054
200	6073192	UP	18-2002/18-2002	18-2013/18-2014	-	18-2054
220	B117316	UP	18-2002/18-2002	18-2013/18-2014	-	18-2054
225	5628028	D280813	18-2002/18-2002	18-2013/18-2014	-	18-2054
250/275	C101891	UP	18-2002/18-2002	-	-	18-2054
3.4	5611648	UP	18-2002/18-2002	-	-	18-2054

POWER TRIM OIL SEAL

H.P.	Beginning S/N	Ending S/N	Oil Seals	Qty.	Desc.
115	2836019	3525440	18-2048	1	Starboard Mounting Bracket
140	3293234	UP	18-2048	1	Starboard Mounting Bracket
150	3502806	4865677	18-2048	1	Starboard Mounting Bracket
150 XS	4868648	5327662	18-2048	1	Starboard Mounting Bracket

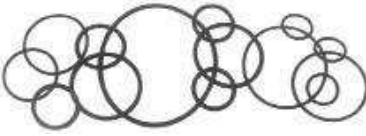
		Part #	O.E. #	DIMENSIONS (in.)	
				O.D.	Width
		18-7165 ②④	25-32509	0.5	0.065
		18-7166 ②④	25-45254	0.615	0.065
		18-7167 ②④	25-861844	3.609	0.139
		18-7168 ②④	25-20587, 25-21720, 25-26834, 25-48171, 25-801334436	0.37	0.065
		18-7169 ②④	25-35984, 25-70937	3.5	0.135
		18-7170 ②④	25-33504	1.365	0.135
		18-7171 ②④	25-30529	1.92	0.1
		18-7172 ②④	25-31305	3.25	0.135
		18-7173 ②④	25-27018, 25-30224Q	1.875	0.135
		18-7174 ②④	25-45711	0.62	0.1
		18-7175 ②④	25-62817	3.75	0.27
		18-7176 ②④	25-896523, 25-F74305, F74305-1, F74305, F694555	2.16	0.1
		18-7177 ②④	25-53421, 25-59712	2.625	0.065
		18-7180 ②④	12-31060, 25-26802, 25-8M2000926	0.445	0.09
		18-7188 ②	25-805726	0.361	0.0635
		18-7195 ②	25-8M0027717	2.75	0.07
		18-7198 ②④	25-45710	1.43	0.1
		18-7410 ②④	25-36390	0.676	0.07
		18-7411 ②④	25-35480, 25-47386, 25-8M2000816	1.25	0.1
		18-7413 ②④	22-22175, 25-62702, 25-F50342-1, F50342, F17510	0.301	0.07
		18-7414 ②④	25-62384, 25-823683	1.989	0.07
		18-7415 ②④	25-64966	3.739	0.07
		18-7419 ②④	25-69202	2.675	0.103
		18-7420 ②④	25-21836	0.796	0.139
		18-7421 ②④	25-16524	0.15	0.065
		18-7426 ③④	25-30271	0.74	0.31
		18-7440-1 ③	25-36318	0.799	0.103
		18-7445 ③④	25-55801	0.801	0.07
		18-7449 ①	25-97387	4.487	0.103
		18-7459 ①	20311, 25-20826	2.234	0.139
		18-7464 ①	25-39695, 25-846361	4.234	0.139
		18-7467 ②④	25-54030, 25-F523555, F532555	2.987	0.103
		18-7474 ①	25-94288	1.239	0.07
		18-7956 ③④	25-85549	2.48	0.1969
		18-7100 ②④	25-85594	0.2362	0.1575
		18-7961	25-47254	3.65	0.135
		18-76695	25-803513007	1.220	.095

① Pkg. of 1 ② Pkg. of 5 ③ Pkg. of 2

MARINER O-RINGS (Japanese Models)

Part No.	O.E. No.	Dimensions		Part No.	O.E. No.	Dimensions	
		I. D.	Width (mm)			I. D.	Width (mm)
18-0298	25-82275M	41.50	3.0	18-0299	25-82289M	66.04	5.33

POWERHEAD SEALS & O-RING APPLICATION

Model	Beginning Serial #	Ending Serial #	Lower O-Ring	Lower Oil Seal	Upper O-Ring	Upper Oil Seal
3.5 (1cyl)	6202173	& UP	N/A	N.L.A	18-7152	N/A
3.9 (39) (1cyl)	1655013	2498135	N/A	N.L.A	18-7152	N.L.A
4 (1cyl)	1655013	2498135	N/A	N/A	18-7152	N/A
4 (40) (1cyl)	2498136	2693114	N/A	N.L.A	18-7152	N.L.A
4 (1cyl)	2771622	4107219	N.L.A.	N/A	18-7152	N.L.A
4 (40) (2cyl)	5589202	& UP	18-7102	N/A	N/A	18-0515
4.5 (4.5, 45) (1cyl)	4107220	4597261	N/A	N/A	18-7152	N.L.A
4.5 (4.5, 45) (1cyl)	4597262	5595531	N/A	N.L.A	18-7152	N/A
4.5 (4.5, 45) (1cyl)	5595532	& UP	N/A	N.L.A	18-7152	N/A
6 (60)	1916139	2529894	N/A	N.L.A	18-7459	N.L.A
6 (2cyl)	1408611	2529894	N/A	N/A	18-7152	N/A
7.5 (75)	2529895	2721150	N/A	N.L.A	18-7152	N.L.A

④ This product is priced per piece. To order priced per package, please add -9 to the part number.

POWERHEAD SEALS & O-RING APPLICATION

Model	Beginning Serial #	Ending Serial #	Lower O-Ring	Lower Oil Seal	Upper O-Ring	Upper Oil Seal
7.5 (2cyl)	2810637	3801457	N/A	N.L.A	18-7152	N/A
7.5 (75) (2cyl)	3274633	& UP	N/A	N/A	18-7152	N/A
7.5 (7.5, 75)	3801458	& UP	N/A	N/A	18-7152	N/A
9.8 (110)	1865779	2798056	N/A	N.L.A	18-7152	N.L.A
9.8 (110)	2798057	3795657	N/A	N.L.A	18-7152	N/A
9.8 (2cyl)	2810637	3274633	N/A	N/A	18-7152	N/A
9.8 (9.8, 110)	3795658	& UP	N/A	N/A	18-7152	N/A
9.8 (2cyl)	3274633	& UP	N/A	N/A	18-7152	N/A
10 (100)	1290910	1499331	N/A	18-2026	N.L.A.	N.L.A
110 (2cyl)	2810637	3274633	N/A	N/A	18-7152	N/A
110 (2cyl)	3274633	& UP	N/A	N/A	18-7152	N/A
15 (150)	1290910	1499331	N/A	18-2026	N.L.A.	N.L.A
15 (SEA PRO)	G044365	G437999	N/A	18-0537	N/A	N/A
15 (SEA PRO)	G438000	& UP	N/A	26-12566 1	N/A	N/A
15 (SUPER)	B238464	& UP	N/A	18-0537	N/A	N/A
15 (18, 18XD)	5837437	& UP	N/A	18-0537	N/A	N/A
20 (200)	1290910	1499331	N/A	18-2026	N.L.A.	N.L.A
20 (200)	1558310	2031773	N/A	18-2026	N.L.A.	N/A
20 (2cyl)	2031774	2827677	N/A	N/A	18-7151	N/A
20 (20, 200)	2827677	6443972	N/A	18-2056	18-7151	N/A
20 (20, 20XD)	6443973	T800749	N/A	18-0537	N/A	N/A
20 JET	G044027	& UP	N/A	18-0537	N/A	N/A
25 (250)	1290910	1499331	N/A	18-2026	N.L.A.	N.L.A
25 (25, 25XD) (2cyl)	5705532	& UP	N/A	18-0537	N/A	N/A
30 (2cyl)	1271885	1448139	18-7151	N.L.A	18-7151	18-2016
30 (2cyl) 644cc	G053314	& UP	18-7176	18-2016	N/A	N/A
30 (2cyl) 430cc	G575500	& UP	N/A	18-2016	N/A	N/A
30 JET (4cyl)	C159200	D279349	18-7161	18-2016	18-7151	18-2016
30 JET (4cyl)	D279350	& UP	18-7161	18-2016	18-7151	18-2016
30 JET (3cyl)	G531301	& UP	18-7176	18-2016	N/A	N/A
MK 35A (2cyl)	1217222	1271884	18-7151	N/A	18-7151	N/A
35 (350)	1271884	1448139	18-7151	N.L.A	18-7151	18-2016
35 (2cyl)	1356948	1571113	18-7151	N/A	18-7151	N/A
35 (2cyl)	1571114	2874703	18-7151	N/A	18-7172	N.L.A
35 (2cyl)	6445653	& UP	18-7414	18-2016	18-7167	18-2016
40 (402) (2cyl)	1279685	1476509	18-7151	N/A	18-7151	18-2016
40 (4cyl)	1279685	2874703	18-7151	N/A	18-7151	N/A
40 (2cyl)	2874704	3336257	N/A	18-2016	18-7167	18-2016
40 (2cyl)	3336258	3346479	N/A	18-2016	18-7961	18-2016
40 (2cyl)	3336258	4117709	N/A	N/A	18-7167	N/A
40 (2cyl)	4117710	& UP	18-7414	18-2016	18-7167	18-2016
40 (2cyl)	5556230	6445653	18-7414	N/A	18-7167	N/A
40 (4cyl)	C159200	D279349	18-7161	18-2016	18-7151	18-2016
40 (402) (2cyl)	3477010	4117709	N/A	18-2016	N/A	18-2016
40 (2cyl) 644cc	G053314	& UP	18-7176	18-2016	N/A	N/A
40 (4cyl)	D279350	& UP	18-7161	18-2016	18-7151	18-2016
40 (3cyl)	G531301	& UP	18-7176	18-2016	N/A	N/A
45 (450) (4cyl)	1476510	1531568	18-7151	N.L.A	18-7151	18-2016
45 (4cyl)	5531630	& UP	18-7151	18-7151	18-7151	18-2016
45 JET	D000750	G589999	18-7176	18-2016	18-7176	N/A
45 JET	G590000	& UP	18-7176	18-2016	N/A	N/A
50 (500) (4cyl)	1421113	1639472	18-7151	18-7151	18-7151	18-2016
50 (500) (4cyl)	1639473	2858813	18-7151	N/A	18-7151	18-2016
50 (50, 500) (4cyl)	2855514	& UP	18-7151	18-2016	18-7151	18-2016
50 (3cyl)	D000750	G589999	18-7176	18-2016	N/A	N/A
50 (3cyl)	6428681	D000750	18-7161	18-2016	18-7415	18-2016
50 (3cyl)	D000750	& UP	18-7176	N/A	N/A	N/A
50 (3cyl)	G590000	& UP	18-7176	18-2016	N/A	N/A
55 (3cyl)	D000750	G589999	18-7176	18-2016	N/A	N/A
55 (3cyl)	G590000	& UP	18-7176	18-2016	N/A	N/A
60 (3cyl)	6428681	D000749	18-7161	18-2016	18-7415	18-2016
60 (3cyl)	D000750	& UP	18-7176	N/A	N/A	N/A
60 (600) (4cyl)	1303411	1542744	18-7151	N/A	18-7151	18-2016
60 (3cyl)	D000750	G589999	18-7176	18-2016	N/A	N/A
65 (650) (4cyl)	1542745	2803561	18-7151	N/A	18-7172	18-2016
65 (650) (4cyl)	2803562	3203183	18-7151	18-2016	18-7172	18-2016
65 (650) (3cyl)	3293184	4571651	18-7161	18-2016	18-7167	18-2016
65 (3cyl)	3547987	4571651	18-7161	N/A	18-7415	N/A
65 JET	D283222	& UP	N/A	18-2016	18-7414	18-0523
70 (700) (6cyl)	1296411	1566239	18-7151	N/A	18-7151	18-2016
70 (3cyl)	4571652	6428680	18-7161	18-2016	18-7415	18-2016
70 (3cyl)	A996142	B240450	N/A	18-2016	18-7414	18-0523

APPLICATION CHART CONTINUES ON NEXT PAGE

POWERHEAD SEALS & O-RING APPLICATION (Cont.)

Model	Beginning Serial #	Ending Serial #	Lower O-Ring	Lower Oil Seal	Upper O-Ring	Upper Oil Seal
70 (3cyl)	B240451	& UP	18-0858	18-2016	18-7414	18-0523
75 (4cyl)	6432901	& UP	18-7161	18-2016	18-7961	18-2016
75 (3cyl)	C222000	& UP	N/A	18-2016	18-7414	18-0523
80 (800) (6cyl)	1335465	1566239	18-7151	N/A	18-7151	18-2016
80 (800) (4cyl)	2559001	3493912	18-7151	18-2016	18-7961	18-2016
80 (80, 800) (4cyl)	4831999	6432900	18-7161	18-2016	18-7961	18-2016
80 (3cyl)	A996142	B240450	N/A	18-2016	18-7414	18-0523
80 (3cyl)	B240451	& UP	18-0858	18-2016	18-7414	18-0523
80 JET	D283222	G760299	N/A	18-2016	18-7414	18-0523
80 JET w/ROUND UPPER O-RING	G760300	& UP	N/A	18-2016	18-7414	18-0523
80 JET w/SQUARE UPPER O-RING	G760300	& UP	N/A	18-2016	N/A	18-0523
85 (850) (6cyl)	1460999	1464848	18-7151	N/A	18-7151	18-2016
85 (850) (6cyl)	1566240	1766823	18-7151	N/A	N.L.A.	18-2016
85 (850) (4cyl)	3493913	4831998	18-7161	18-2016	18-7961	18-2016
90 (900) (6cyl)	1766824	1869775	18-7151	N/A	N.L.A.	18-2016
90 (90, 900) (6cyl)	4845301	& UP	18-7161	18-2016	18-7961	18-2016
90 (3cyl)	A996142	B240450	N/A	18-2016	18-7414	18-0523
90 (3cyl)	B240451	C221999	18-0858	18-2016	18-7414	18-0523
90 (3cyl)	C222000	& UP	N/A	18-2016	18-7414	18-0523
95 (950) (6cyl)	1869776	2318585	18-7151	N/A	N.L.A.	18-2016
100 (1000) (6cyl)	1464949	2318585	18-7151	N/A	N.L.A.	18-2016
100 (1000SS) (6cyl)	2318586	2413847	18-7151	N/A	N.L.A.	18-2016
100 (1000SS) (6cyl)	2484633	2836018	18-7151	18-2016	N.L.A.	18-2016
100 (1000BP) (6cyl)	2399698	2641854	18-7151	18-2016	N.L.A.	18-2016
100 (1000BP) (6cyl)	2641855	3253111	18-7151	18-2016	18-7961	18-2016
100 (4cyl)	B209468	G760299	N/A	18-2016	18-7414	18-0523
100 w/ROUND UPPER O-RING (4cyl)	G760300	& UP	N/A	18-2016	18-7414	18-0523
100 w/SQUARE UPPER O-RING (4cyl)	G760300	& UP	N/A	18-2016	25-858225	18-0523
110 (1100)	1870201	2314955	18-7151	N/A	N.L.A.	18-2016
115 (1150) (6cyl)	2836019	3525440	18-7151	18-2016	18-7961	18-2016
115 (115, 1150) (6cyl)	3525441	& UP	18-7161	18-2016	18-7961	18-2016
115 (4cyl)	C100000	G760299	N/A	18-2016	18-7414	18-0523
115 w/ROUND UPPER O-RING (4cyl)	G760300	& UP	N/A	18-2016	18-7414	18-0523
115 w/SQUARE UPPER O-RING (4cyl)	G760300	& UP	N/A	18-2016	N/A	18-0523
115 DFI (1.5L)	T801000	& UP	N/A	18-2016	N/A	N/A
115 PRO XS	B751825	& UP	N/A	18-2016	N/A	N/A
125 (1250) (6cyl)	2314956	2839368	18-7151	N/A	18-7961	18-2016
125 (4cyl)	D283222	G760299	N/A	18-2016	18-7414	18-0523
125 w/ROUND UPPER O-RING (4cyl)	G760300	& UP	N/A	18-2016	18-7414	18-0523
125 w/SQUARE UPPER O-RING (4cyl)	G760300	& UP	N/A	18-2016	N/A	18-0523
135 (1350) (6cyl)	2839369	3293233	18-7151	18-2016	18-7961	18-2016
140 (140, 1400) (6cyl)	3293234	& UP	18-7161	18-2016	18-7961	18-2016
150 (1500) (6cyl)	3502806	4865677	18-7161	18-2016	18-7961	18-2016
150 (1500XS) (6cyl)	4868648	5327662	18-7161	18-2016	18-7961	18-2016
V-105 JET	D082000	& UP	18-0860	18-2016	18-0858	18-2016
V-135 CARB w/1.50 ID UPPER BRG	A904646	C100860	18-0860	18-2016	18-0858	18-2016
V-135 CARB w/1.37 ID UPPER BRG	A904646	C100860	18-0860	18-2016	18-0858	18-2016
V-135 CARB	C100861	& UP	18-0860	18-2016	18-0858	18-2016
V-135 CARB	C239553	& UP	18-0860	18-2016	18-0858	18-2016
V-135 DFI	G590000	& UP	18-0860	18-2016	18-0858	18-2016
V-140 JET	D082000	& UP	18-0860	18-2016	18-0858	18-2016
V-150 (V-1500) CARB	4868998	A904645	N/A	18-2016	N/A	18-2016
V-150 w/1.50 ID UPPER BRG	A904646	C100860	18-0860	18-2016	18-0858	18-2016
V-150 w/1.37 ID UPPER BRG	A904646	C100860	18-0860	18-2016	18-0858	18-2016
V-150 CARB	C100861	C239552	18-0860	18-2016	18-0858	18-2016
V-150 XR4 / MAGNUM II	B242885	C239552	18-0860	18-2016	18-0858	18-2016
V-150 CARB	C239553	& UP	18-0860	18-2016	18-0858	18-2016
V-150 XR4 / 6 MAG II, III	C239553	& UP	18-0860	18-2016	18-0858	18-2016
V-150 EFI	D082000	& UP	18-0860	18-2016	18-0858	18-2016
V-150 DFI	G590000	& UP	18-0860	18-2016	18-0858	18-2016
V-175 (V-175, 1750) CARB	4301235	5393736	N/A	18-2016	N/A	18-2016
V-175 CARB	5393737	6618750	N/A	18-2016	N/A	18-2016
V-175 CARB	6618751	C239552	18-0860	18-2016	18-0858	18-2016
V-175 CARB	C239553	& UP	18-0860	18-2016	18-0858	18-2016
V-175 EFI	D000750	& UP	18-0860	18-2016	18-0858	18-2016
V-175 DFI	T178500	& UP	18-0860	18-2016	18-0858	18-2016
V-175 PRO XS	B516339	& UP	18-0860	18-2016	18-0858	18-2016
V-200 (V-200, 2000) CARB	4839034	5363917	25-67207	18-2016	N/A	18-2016
V-200 CARB	5363918	6073191	N/A	18-2016	N/A	18-2016
V-200 CARB	6073192	C291519	18-0860	18-2016	18-0858	18-2016
V-200 CARB	C291520	& UP	18-0860	18-2016	18-0858	18-2016
V-200 EFI	C100861	C291519	18-0860	18-2016	18-0858	18-2016

APPLICATION CHART CONTINUES ON NEXT PAGE

POWERHEAD SEALS & O-RING APPLICATION

Model	Beginning Serial #	Ending Serial #	Lower O-Ring	Lower Oil Seal	Upper O-Ring	Upper Oil Seal
V-200 EFI (2.5L)	C291520	& UP	18-0860	18-2016	18-0858	18-2016
V-200 DFI	G386496	& UP	18-0860	N/A	18-7414	N/A
V-200 PRO XS	B504989	& UP	18-0860	N/A	18-7414	N/A
V-200 LASER	B117316	& UP	18-0860	18-2016	18-0858	18-2016
V-225 (2.4L)	5628028	& UP	18-0860	18-2016	N/A	18-2016
V-225 (3.0L) SEA PRO / MARATHON CARB	G245605	G303045	18-0860	N/A	18-7414	N/A
V-225 (3.0L) SEA PRO / MARATHON CARB	G303046	& UP	18-0860	N/A	18-7414	N/A
V-225 DFI	G590000	& UP	18-0860	N/A	18-7414	N/A
V-225 PRO XS	B104549	& UP	18-0860	N/A	18-7414	N/A
V-225 EFI	G129222	G303045	18-0860	N/A	18-7414	N/A
V-225 EFI	G303046	& UP	18-0860	N/A	18-7414	N/A
V-250 w/o UPPER BEARING FITTING	C101891	& UP	N/A	N.L.A	18-7414	18-2016
V-250 w/UPPER BEARING FITTING	C101891	& UP	N/A	N.L.A	18-7414	18-2016
V-250 EFI	G129222	G303045	18-0860	N/A	18-7414	N/A
V-250 EFI	G303046	& UP	18-0860	N/A	18-7414	N/A
V-250 DFI	B528615	& UP	18-0860	N/A	18-7414	N/A
V-250 PRO XS	B426561	& UP	18-0860	N/A	18-7414	N/A
V-275 CARB w/o UPPER BEARING FITTING	C101891	& UP	N/A	N.L.A	18-7414	N/A
V-275 CARB w/UPPER BEARING FITTING	C101891	& UP	N/A	N.L.A	18-7414	N/A
V-300 (3.4L)	5611648	& UP	N/A	N.L.A	18-7414	N/A

① Requires 2 ② Shift Shaft Retainer ④ Fits most applications

LOWER UNIT O-RING APPLICATION

HP	Beg. S/N	End S/N	Bearing Carrier	Water Pump Base	Shift Shaft	Drive Shaft
3.9	1655013	2498135	18-7121	18-7156	18-7180	18-7168
4	2498136	5589201	18-7121	18-7156	18-7180	18-7168
4/4.5	5589203	A809601	18-7171	18-7156	18-7180	-
6	1408611	2529894	18-7171	18-7156	18-7180	18-7168
6	A197112	UP	18-7162	-	-	-
7.5	2529895	3801457	18-7171	18-7156	18-7180	18-7168
7.5	3801458	5206549	18-7171	18-7156	18-7180	-
7.5	5206550	UP	18-7171	18-7156	18-7180	18-7116
8	A197112	UP	18-7162	-	-	-
9.8	1470349	3795657	18-7171	18-7156	18-7180	18-7168
9.8	3795658	5206549	18-7171	18-7156	18-7180	-
9.8	5206550	UP	18-7171	18-7156	18-7180	18-7116
9.9/15	A197112	UP	18-7162	-	-	-
18	5837437	6443972	-	18-7419	-	-
20	1558310	1866494	18-7163	18-7164	18-7180	18-7180
20	1866495	6443972	18-7163	18-7164	18-7180	18-7180
25	5705532	6443972	-	18-7419	-	-
18/20/25XD	6443973	UP	-	18-7419	18-7135 ②	-
30	1271885	1356947	18-7152	18-7115	18-7153	-
30	G055314	UP	-	-	18-7155 ②	-
MK 35A	1217222	1271884	18-7152	18-7115	18-7153	-
35	1356948	1448139	18-7152	18-7115	18-7153	-
35	1571114	1960826	18-7160	18-7155	18-7153	-
35	1960827	2874703	18-7160	18-7155	18-7153	-
35	6445653	UP	18-7160	18-7115	18-7153	-
40	1279685	2874703	18-7152	18-7115	18-7153	-
40	2874704	3336257	18-7160	18-7155	18-7153	-
40	3336258	4117709	18-7160	18-7155	18-7153	-
40	4117710	4860102	18-7160	18-7155	18-7153	-
40	4860103	6445652	18-7160	18-7115	18-7153	-
40 4cyl	C159200	G053313	18-7160	18-7115	18-7153	-
40 2cyl	G055314	UP	-	-	18-7155 ②	-
45	1476510	1531568	18-7160	18-7155	18-7153	-
45 4cyl	5531630	UP	18-7160	18-7115	18-7153	-
50	1421113	1639472	18-7152	18-7155	18-7153	-
50	1639473	1770178	18-7160	18-7155	18-7153	-

① Requires 2 ② Shift Shaft Retainer ④ Fits most applications

LOWER UNIT O-RING APPLICATION

HP	Beg. S/N	End S/N	Bearing Carrier	Water Pump Base	Shift Shaft	Drive Shaft
50	1770179	2305100	18-7160	18-7155	18-7153	-
50	2305101	2858813	18-7160	18-7155	18-7153	-
50	2858814	4140999	18-7160	18-7155	18-7153	-
50	4141000	4962055	18-7160	18-7155	18-7153	-
50	4962056	5531630	18-7160	18-7155	18-7153	-
50 3cyl	6428681	D000750	18-7160	18-7155	18-7153	-
50/55/60 3 cyl	D000751	UP	-	18-7173	-	-
60	1303411	1542744	-	18-7115	-	-
60	6428681	D000750	18-7160	18-7155	18-7153	-
65	1542745	2874263	18-7157	18-7173	18-7153	18-7158
65	2874263	3293183	18-7157	18-7162	18-7153	18-7158
65 3cyl	3293184	4136684	18-7160	18-7155	18-7153	-
65 3cyl	4136685	4571651	18-7160	18-7155	18-7153	-
70	1296411	1413610	18-7114	18-7155 ①	-	-
70	1413611	1566239	18-7157	18-7173	18-7153	18-7158
70 3cyl	4571652	4977156	18-7160	18-7155	18-7153	-
70 3cyl	4977157	5579016	18-7160	18-7115	18-7153	-
70 3cyl	5579017	A996142	18-7160	18-7115	18-7153	-
70/75 3cyl	A996142	UP	-	-	18-7198	-
75 4cyl	6432901	A996142	18-7157	18-7162	18-7153	-
80	1335465	1398629	18-7157	18-7155	18-7153	18-7158
80	1398630	1566239	18-7157	18-7173	18-7153	18-7158
80 4cyl	2559001	3144218	18-7157	18-7173	18-7153	18-7158
80 4cyl	3144219	4831998	18-7157	18-7162	18-7153	-
80 4cyl	4831999	5582561	18-7157	18-7162	18-7153	-
80 4cyl	5582562	A996142	18-7157	18-7162	18-7153	-
80 3cyl	A996142	UP	-	-	18-7198	-
85	1460999	1766823	18-7157	18-7173	18-7153	18-7158
85 4cyl	3493913	4590511	18-7157	18-7162	18-7153	-
85 4cyl	4590512	4831998	18-7157	18-7162	18-7153	-
90	1766824	1869775	18-7157	18-7162	18-7153	18-7158
90	4845301	5594656	18-7157	18-7162	18-7153	-
90	5594657	A996142	18-7157	18-7162	18-7153	-
90 3cyl	A996142	UP	-	-	18-7198	-
95	1869776	2318585	18-7157	18-7173	18-7153	18-7158
100,100SS	1464949	2836018	18-7157	18-7173	18-7153	18-7158
100BP	2399698	2641854	18-7157	18-7173	18-7153	18-7158
100 4cyl	B209468		-	-	18-7198	-
110	1870204	2314955	18-7157	18-7173	18-7153	18-7158
115	2836019	3525440	18-7157	18-7173	18-7153	18-7158
115	3525440	41122634	18-7157	18-7173	18-7153	-
115	41122635	4855152	18-7157	18-7162	18-7153	-
115	4855153	5600966	18-7157	18-7162	18-7153	-
115	5600967	C100000	18-7157	18-7162	18-7153	-
115 4cyl	C100000	UP	-	-	18-7198	-
125	2314956	2839368	18-7157	18-7173	18-7153	18-7158
135	2839369	3293233	18-7157	18-7173	18-7153	18-7158
140	3293234	3502805	18-7157	18-7173	18-7153	-
140	4865678	UP	18-7157	18-7162	18-7153	-
150	3502806	4121434	18-7157	18-7173	18-7153	-
150	4121434	5327662	18-7157 ④	18-7162	18-7153	-

V-6

HP	Beg. S/N	End S/N	Bearing Carrier	Water Pump	Shift Shaft	Drive Shaft
150/150XR2	4868998	5432021	18-7159	18-7162	18-7153	-
150/150XRS	5432021	A904646	18-7159	18-7176	18-7153	-

① Requires 2 ② Shift Shaft Retainer ④ Fits most applications

V-6 (Cont.)

HP	Beg. S/N	End S/N	Bearing Carrier	Water Pump	Shift Shaft	Drive Shaft
135/150/XR2	A904646	UP	18-7159	18-7176	18-7153	-
175	4301235	6618750	18-7159	18-7162	18-7153	-
175	6618751	UP	18-7159	18-7176	18-7153	-
200	4839034	6073191	18-7159	18-7162	18-7153	-
200	6073192	UP	18-7159	18-7176	18-7153	-
220	B117316	UP	18-7159	18-7176	18-7153	-
225	5628028	D280813	18-7159	18-7162	18-7153	-
250/275	C101891	UP	18-7159	-	18-7153	-
3.4	5611648	UP	18-7159	-	18-7153	-

SWIVEL BRACKET ASSEMBLY O-RING APPLICATION

HP	Beg. S/N	End S/N	O-Ring	Qty	Desc	HP	Beg. S/N	End S/N	O-Ring	Qty	Desc
3.9	1655013	2498135	18-7153	2	SB	V 135	A904646	UP	18-7174	1	TT
4	2498136	3529445	18-7153	1	SB	V 150	4868998	UP	18-7164	1	SB
6	1436115	2529894	18-7153	2	SB	V 150	5432022	6606990	18-7168	2	TLL
7.5	2529895	3488152	18-7153	2	SB	V 150	6443213	UP	18-7174	1	TT
9.9	1470349	3482752	18-7153	2	SB	V 175	4301235	UP	18-7164	1	SB
35 ①	B110789	C159199	18-7164	1	SB,U	V 175	5488752	6618750	18-7168	2	TLL
35 ①	B110789	C159199	18-7174	1	TT	V 175	6618751	UP	18-7174	1	TT
45 4 Cyl ①	B110789	UP	18-7174	1	TT	V 200	4839034	UP	18-7164	1	SB
45 4 Cyl ①	B110789	UP	18-7164	1	SB,U	V 200	5464486	6625220	18-7168	2	TLL
50 3 Cyl ①	B122930	C160935	18-7164	1	SB,U	V 200	6625221	UP	18-7174	1	TT
50 3 Cyl ①	B122930	C160935	18-7174	1	TT	V 200 EFI	C100861	UP	18-7174	1	TT
60 3 Cyl ①	B122930	C160935	18-7174	1	TT	V 200 EFI	C100861	UP	18-7164	1	SB
60 3 Cyl ①	B122930	C160935	18-7164	1	SB,U	V 220	B117316	UP	18-7174	1	TT
70	A996142	UP	18-7174	2	TT	V 220	B117316	UP	18-7164	1	SB
70	A996142	UP	18-7164	1	SB	V 225	5628028	UP	18-7164	1	SB
75	6432901	UP	18-7174	2	TT	V 225	5628028	UP	18-7168	2	TLL
75	6432901	UP	18-7164	1	SB	V 250	C101891	UP	18-7168	2	TLL
80	A996142	UP	18-7164	1	SB	V 250	C101891	UP	18-7174	1	TT
80	A996142	UP	18-7174	2	TT	V 275	C101891	UP	18-7174	1	TT
90	6436123	UP	18-7164	1	SB	V 275	C101891	UP	18-7168	2	TLL
90	6436123	UP	18-7174	2	TT	3.4 LT	5611648	UP	18-7168	2	TLL
100	B209468	UP	18-7164	1	SB	3.4 LT	5611648	UP	18-7174	1	TT
100	B209468	UP	18-7174	1	TT	3.4 LT	5611648	UP	18-7164	1	SB
115	6436123	UP	18-7164	1	SB	XR-4/Magnum II	B242885	UP	18-7174	1	TT
115	6436123	UP	18-7174	2	TT	XR-4/Magnum II	B242885	UP	18-7164	1	SB
V 135	A904646	UP	18-7164	1	SB						

① Models with power trim only TLL Tilt Lock Lever
 SB,U Swivel Bracket, Upper TT Tilt Tube
 SB Swivel Bracket

