

SEA RAY		
MODEL NO.	S/N	YEAR
3.0L	B787205-B917529	1988
4.3L	B785483-B921276	1988
4.3LX	B785981-B922330	1988
5.7L	B784799-B917017	1988
SRX5.7L, 350 Mag	B785241-B919012	1988
SRX7.4L, 454 Mag Alpha	B785149-B924857	1988
SRX7.4L-H, 454 Mag Bravo	B721206-B919343	1988

STERN DRIVES		
MODEL NO.	S/N	YEAR
SRX7.4L, Alpha	B803866-C348032	1988
SRX7.4L-H, Bravo	B803872-B999972	1988

INBOARD ENGINES		
MODEL NO.	S/N	YEAR
5.7L	B788204-B919356	1988
7.4L	B788179-B913769	1988

RENAULT 4 CYLINDER (STERN DRIVE)		
MODEL	S/N	YEAR
60	1887079-2049044	1965-68
80	2049045-2851423	1966-69
90	2851424-3226957	1970-72

GM 4 CYLINDER (STERN DRIVE)		
MODEL	S/N	YEAR
110	1537370-2044033	1963-66
120	1666601-3377340	1964-72
120	3377341-3770649	1972-73
120	3770650-4952700	1974-77
120	4952701-5192048	1978
120	5192049-6229717	1979-82
120	6229718-6853913	1983-84
120	6853914-B531853	1985-86
120/2.5L	B531854-C853255	1987-89
140	2508261-6229717	1968-82
140/3.0L	6229718-C856558	1982-89
3.0L/LX	C856559-UP	1990-UP

MERCURY MARINE 4 CYLINDER (STERN DRIVE)		
MODEL	S/N	YEAR
470 (2bbl.)	4208730-5520114	1976-79
470 (2bbl.)	5520115-6218036	1980-82
470 (2bbl.)	6218037-6916778	1983-84
170 (2bbl.)	6916779-UP	1985-86
165/3.7L (2bbl.)	6916779-UP	1987-89
485 (2bbl.)	5685394-6218036	1980-82
488 (4bbl.)	6170297-6916778	1983-84
190 (4bbl.)	6916779-UP	1985-86
180/3.7LX (4bbl.)	6916779-UP	1987-89

GM INLINE 6 CYLINDER (STERN DRIVE)		
MODEL	S/N	YEAR
140	1538930-1725960	1963
150	1666495-2048046	1964-66
160	2048022-2770031	1967-69
165	2770032-5178958	1970-78
165	5178959-5813433	1979-81
200	2453769-2712072	1969

GM V6 (STERN DRIVE)		
MODEL	S/N	YEAR
185 (4bbl.)	6330183-6919655	1983-84
185 (2bbl.)	A331455-B527954	1985-87
175/4.3L (2bbl.)	B527955-D714106	1987-92
4.3L (GEN II)(2bbl.)	D714107-F000877	1992-93
4.3L (GEN II)(2bbl.)	F000878-F601126	1993-95
4.3L (GEN II)(2bbl.)	F601127-F000878	1996
4.3LX (GEN+)(2bbl.)	F803000-K999999	1996-97
4.3L (GEN+)(2bbl.)	L010044-UP	1998-UP
4.3L EFI (GEN+)(TBI)	L012009-UP	1998-UP
205 (4bbl.)	A331455-B527954	1985-87
205/4.3LX (4bbl.)	B527955-D714369	1987-91
4.3LX (GEN II)(4bbl.)	D714370-F001219	1992-93
4.3LX (GEN II)(4bbl.)	F001220-F601126	1993-95
4.3LX (GEN II)(4bbl.)	F601127-F802999	1996
4.3LXH (GEN+)(4bbl.)	F803114-UP	1996-97
4.3LH(GEN+)(4bbl.)	L010044-UP	1998
262 Mag. (TBI)(GEN+)	F803800-K999999	1996-97

FORD V8 (STERN DRIVE)		
MODEL	S/N	YEAR
888 (2bbl.)	3108723-4887829	1971-77
215 (4bbl.)	2781153-3385720	1970-72
225 (4bbl.)	3385721-4166999	1973-74

FORD V8 (STERN DRIVE) Cont.		
MODEL	S/N	YEAR
225-S (4bbl.)	3385721-4166999	1973-74
233	4173000-4902304	1975-77
255	3258728-4175499	1971-74

GM V8 283, 327, 305 & 350 CID		
MODEL	S/N	YEAR
190	1564539-1730903	1963-64
898 (2bbl.)	4762210-6218461	1977-82
898 (2bbl.)	6218462-B525981	1983-84
200/5.0L (2bbl.)	6218462-F600999	1985-95
5.0L (2bbl.)	L015751-UP	1998-UP
5.0L EFI	L012052-L340000	1998-99
228 (4bbl.)	4765100-5170008	1977-78
228 (4bbl.)	5170009-6218461	1979-82
228 (4bbl.)	6218462-B525981	1982-84
230 (4bbl.)	6218462-B525981	1985-86
230/5.0LX (4bbl.)	B525982-F600999	1987-95
225	1539620-2694014	1963-69
250	2314301-2639854	1968-69
255	4175500-4767999	1975-76
250	4768000-4908849	1977
260/5.7L	4908850-6218461	1978-82
260/5.7L	621462-B525981	1982-86
260/5.7L	B525982-F600999	1987-95
5.7L (2bbl.)	F601000-UP	1996-98
5.7L EFI	F225560-UP	1995-UP
5.7LX (4bbl.)	F601000-K999999	1996-97
5.7LX EFI	F752400-K999999	1996-97
5.7LX Bravo EFI	F800300-K999999	1996-97
350 Mag. Alpha	A635178-B525981	1986-87
350 Mag. Alpha	B525982-F600999	1987-95
350 Mag. Alpha	F601000-K001526	1996
350 Mag. Alpha	K001527-K999999	1997
350 Mag. Alpha EFI	F800300-K999999	1996-97
350 Mag. Bravo MPI	F415189-K999999	1995-97
350 Mag. Bravo MPI (GEN +)	F602000-K999999	1996-97
350 Mag. MPI (GEN+)	L010019-UP	1998-UP
270	2851074-3385720	1969-72
280TRS	4176250-4770199	1975-76
300 Tempest	6668677-B430367	1985-86
320 (EFI)	A543604-C622418	1987-89

GM V8 427, 454, 502, 540 & 572 (STERN DRIVE)		
MODEL	S/N	YEAR
325	2278747-3780449	1969-72
330	4623115-6083144	1977-81
330	6083145-B816450	1982-87
7.4L Bravo	B771113-D603117	1988-91
7.4L Bravo (Gen.V)	D603118-F800699	1992-96
7.4L Bravo (Gen.VI)	F800700-K999999	1996-97
7.4LX Bravo (MPI)(Gen.V)	F602010-F801999	1996
7.4LX Bravo (MPI)(Gen.VI)	F802000-K999999	1996-97
7.4L MPI (Gen.VI)	L010003-UP	1998
7.4LX Bravo (TBI)(Gen.VI)	F820000-K999999	1996-97
454 Mag. Alpha	A631894-UP	1986-88
454 Mag. Bravo (Gen.V)	D805069-F304999	1992-94
454 Mag. Bravo (Gen.V)	F305000-F801699	1995-96
454 Mag. Bravo (Gen.VI)	F801700-K999999	1996-97
454 EFI (Gen.V)	F115700-F802349	1994-96
454 Mag. MPI (Gen.VI)	F802350-K999999	1996-97
454 Mag. MPI (Gen.VI)	L010029-L085399	1998
454 Mag. MPI (Gen.VI)	L085400-UP	1999-UP
370 TRS	4179554-6721527	1978-85
370 TRS	6721528-B714586	1985-87
400 TRS	4179554-B457644	1980-86
420	A398941-D937011	1987-89
425	A398941-D937011	1990-93
440 TRS	4179554-B485220	1983-86
450 (Gen.V)	F347100-F347277	1995-96
525 SC	D456000-F348963	1991-92
525 SC (Gen.V)	D456000-F348963	1992-95
525 SC (Gen.V)	F615814-F745215	1996
525 SC (Gen.VI)	F745260-UP	1996-97
390	2781129-3042731	1969-70
460 TRS	4719554-6181046	1983-86
465	C849992-F213244	1990-92
465 (Gen.V)	C849992-F213244	1992-94
500 (Gen.V)	F213293-F745159	1994-96

GM V8 427, 454, 502, 540 & 572 (STERN DRIVE) Cont.			GM MIE V8 427, 454, 482 & 502 CID (INBOARD)		
MODEL	S/N	YEAR	MODEL	S/N	YEAR
500 (Gen.VI)	F745195-L001772	1997-98	8.2L MPI (LH) Gen VI	L002450-L0086012	1998
502 Mag. Bravo	C878221-D824588	1990-92	8.2L MPI (LH) Gen VI	L0086013-UP	1999
502 Mag. Bravo (Gen.V)	D824589-F114528	1992-93	MIE 5, 6 & V8 CYLINDER DIESEL INBOARD ENGINES		
502 EFI (Gen.V)	D840650-F802599	1993-96	MODEL	HP	S/N
502 Mag.MPI (Gen.VI)	F802600-K999999	1996-97	530 D-TA	150	B993002-C539258
500 EFI	L001477-UP	1999-UP	636 D-TA	180	B993750-C696011
502 Mag.MPI (Gen.VI)	L085433-UP	1998	D183	150	C539259-D725149
600 SC	D456489-F877642	1991-92	D219	180	C696012-D850124
600 SC (Gen.V)	D456489-F877642	1992-96	D254	210	C849461-D554729
600 SC (Gen.VI)	K000227-UP	1997	D3.0L	150	D725150-UP
500 Bulldog	C577254-F745405	1990-96	D3.6L	180	D850125-UP
500 Bulldog	K000248-UP	1997	D4.2L	210	D554730-UP
575	A677429-D763716	1986-92	D7.3L	262	F060000-UP
800 SC (Gen.V)	D763836-UP	1993-96	MC 60, 80 & 90 STERN DRIVES & TRANSOM PLATES		
MCM 4,5,6 & V8 CYLINDER DIESEL STERN DRIVE ENGINE			MODEL	S/N	YEAR
MODEL	HP	S/N	YEAR		
Rover	60	31400000F-UP	1965-67		
530 D-TA	150	B993000-B993492	1989		
636 D-TA	180	B993500-C696047	1989		
D183	140	B993493-D725149	1990-93		
D219	170	C696048-D850124	1990-93		
D254	200	C849484-D554729	1990-93		
D3.0L	140	D725150-UP	1994-UP		
D3.6L	170	D850125-UP	1994-UP		
D4.2L	200	D554730-UP	1994-UP		
D7.3L	238	F060000-UP	1994-UP		
MERCURY MARINE MIE 4 CYLINDER (INBOARD)			MC I, II & III		
MODEL	S/N	YEAR	MODEL	S/N	YEAR
470	5520115-6218036	1980-81	60 (O)	1830753-2063740	1965-66
FORD MIE V8 (INBOARD)			80	2063741-2898029	1966-69
MODEL	S/N	YEAR	90	2898020-3225967	1970-72
215	2781153-3563181	1970-72	MC I, II & III Cont.		
225	3385721-4176999	1970-72	MODEL	S/N	YEAR
233	4173000-4775784	1975-76	I	1534570-1684187	1963
255	3258728-4178299	1973-74	II (1.33:1)	1474909-2278488	1962-67
GM MIE V8 305,327,350 CID (INBOARD)			MC 1A, 1B & 1C		
MODEL	S/N	YEAR	MODEL	S/N	YEAR
198	4762210-6218461	1977	1A, 1B & 1C	1684188-1777798	1964
228	4765100-5170008	1977-78	1A, 1B & 1C (E-Z Shift)	1776349-2065189	1965-66
228	5170009-5907057	1979-80	MC 120, 140, 160 & 165		
230/5.0L (4bbl.)	5907058-B788151	1981-87	MODEL	S/N	YEAR
225	2278647-2694014	1968	120/140	2062141-378049	1967-73
250	2314301-2639854	1968-69	120/140	3780850-4893634	1974-77
255	4175500-5907057	1975-80	120/140	4893635-6225576	1978-82
260/5.7L	5907058-F024999	1981-93	160	2065190-2763441	1967-69
270	2851074-3077735	1969-72	165	2763442-3780849	1970-73
5.7L	F025000-K999999	1994-97	165	3780849-4890459	1974-77
5.7L (Gen+)	L002003-UP	1998	165	4890460-6268064	1978-82
5.7L MPI	K040300-K999999	1997	MC470 & 485		
350 Mag. MPI (Gen+)	L002008-L304499	1998	MODEL	S/N	YEAR
350 Mag. MPI (Gen+)	L304500-UP	1999	470	4208730-4893834	1976-77
350 Horizon	L304700-UP	1999-UP	470	4893835-6225576	1978-82
5.7L Ski	A338533-B514626	1985-87	485	5487437-6225576	1980-82
5.7L Competition Ski	B514627-F775199	1987-95	MC 888, 225S & 233		
5.7L Competition Ski	F775200-K040003	1996	MODEL	S/N	YEAR
5.7L Competition Ski	K040004-K999999	1997	888	3106717-3784374	1971-73
5.7L Competition Ski (Gen+)	L002005-UP	1998-UP	888	3784375-4782329	1974-77
350 Mag. Ski	D505450-K999999	1991-97	225S	3856268-4200499	1974
350 Mag. EFI Ski	F215561-K999999	1994-97	233	4200500-4782329	1975-77
350 Mag. MPI Ski	F350583-F799999	1995-98	MC 898, 228, 250 & 260		
Black Scorpion Ski	F800000-UP	1996-98	MODEL	S/N	YEAR
GM MIE V8 427, 454, 482 & 502 CID (INBOARD)			898/228	4782330-4898729	1977
MODEL	S/N	YEAR	898/228	4898730-6229157	1978-82
325	2278747-3780449	1968-74	250	4791300-4898729	1977
330	4623115-5889913	1977-80	260	4898730-6229157	1978-82
340/7.4L w/B/W MK4	5889914-UP	1981-92	MC R, MR, ALPHA ONE, ALPHA ONE SS & ALPHA ONE GEN II		
7.4L w/Hurth (LH) MK4	C391564-D715493	1989-92	MODEL	S/N	YEAR
7.4L (LH)	D715494-K999999	1992-97	R	6152230-6847029	1983-84
7.4L MPI (LH)	F563052-K999999	1995-97	MR	6810538-A479506	1985
7.4L MPI (L29) Gen VI	L002006-UP	1998	Alpha One	A470165-UP	1986-90
7.4L TBI (LH) Gen VI	F874815-K999999	1996-97	Alpha One SS	A545004-UP	1986-89
454 Mag. MPI Horizon	L002200-L086049	1998-99	Alpha One Gen II	D469859-UP	1991-UP
454 EFI (SKI) (Gen.V)	F215800-F820099	1995-96	MC BRAVO & BLACKHAWK		
454 Mag. MPI (SKI)(Gen.VI)	F820100-K999999	1996-97	MODEL	S/N	YEAR
350	9780450-4623109	1974-76	Bravo One	B664190-UP	1988-UP
390	2781129-2825059	1969-70	Bravo Two	C564952-UP	1989-UP
8.2L w/ Hurth	C878221-D857199	1990-92	Bravo Three	D763691-UP	1993-UP
8.2L (Gen.V)	D857200-F819619	1993-96	Blackhawk	F186717-UP	1994-UP
8.2L MPI (LH) Gen VI	F819620-K999999	1996-97	MC 215E & 215H		
			MODEL	S/N	YEAR
			215H	2782203-2909034	1970
			215E	2782203-2909034	1970-72
			MC TR & TRS		
			MODEL	S/N	YEAR
			TR	3377316-3787239	1973
			TR	3787240-4794899	1974-76
			TR	4794900-5009866	1977
			TR	5009867-UP	1978-UP
			TRS	3787240-4203749	1974-75
			TRS	4203750-4795399	1976
			TRS	4795400-UP	1977-UP



18-5291
TUNE-UP KIT

Replaces: 808483K2
GM V-8 engines w/Delco HEI-1998 and newer
(except MPI engines with 555 ECM)
Includes **18-5354** cap & **18-5402** rotor



18-5246
TUNE-UP KIT

Replaces: 898253T28
For: Late model V-6, 4.3L (Alpha/Bravo)



18-5247
TUNE-UP KIT

Replaces: 898253T29, 8M0061335, 8M0060495
For: Late model V-8 (Alpha/Bravo 350
Mag, 5.0L, & MX 6.2L)



① **18-5250D** Display Package

18-5250
TUNE-UP KIT

Replaces: 34235T1, 34235Q1

—CONTAINS—

Part #	O.E. #	Description
18-5311	34235	Contact Set
18-5345	33662	Condenser
18-5418	58217	Rotor

Delco 4 & 6 cyl.



① **18-5251D** Display Package

18-5251
TUNE-UP KIT

—CONTAINS—

Part #	O.E. #	Description
18-5314	391-5090	Contact Set
18-5338	391-5092	Condenser
18-5404-1	391-7057	Rotor

Mallory 8 cyl. Tall Cap



18-5252
TUNE-UP KIT

—CONTAINS—

Part #	Description
18-5310	Contact Set
18-5344	Condenser
-	Rotor

Delco 8 cyl.



18-5253
TUNE-UP KIT

—CONTAINS—

Part #	O.E. #	Description
18-5318	58033	Contact Set
18-5346	58034, 81-64851	Condenser
18-5420	65864	Rotor

Autolite 8 cyl.



① **18-5254D** Display Package

18-5254
TUNE-UP KIT

—CONTAINS—

Part #	O.E. #	Description
18-5317	64850, 87-71831	Contact Set
18-5346	58034, 81-64851	Condenser
18-5420	65864, 78016	Rotor

Mercury 8 cyl.



① **18-5258D** Display Package

18-5258
TUNE-UP KIT

—CONTAINS—

Part #	O.E. #	Description
18-5303	392-6325	Contact Set
18-5347	392-6324	Condenser
18-5407	392-6326	Rotor

Prestolite 8 cyl.



① **18-5260D** Display Package

18-5260
TUNE-UP KIT

—CONTAINS—

Part #	O.E. #	Description
18-5303	392-6325	Contact Set
18-5345	392-6324	Condenser
18-5403	392-9767	Rotor

Prestolite 8 cyl.



18-5266
TUNE-UP KIT

Fits: Flame Thrower Distributors **18-5481**, **18-5482**, **18-5483**, **18-5477**, **18-5478** and **18-5479**
Includes **18-5300** rotor



Display Package

18-5267
TUNE-UP KIT

—CONTAINS—

Part #	O.E. #	Description
18-5318	58033	Contact Set
18-5346	58034, 81-64851	Condenser
18-5420	65864, 78016	Rotor
18-5389	393-4988T	Distributor Cap

Autolite V-8 - Single Point



18-5268
TUNE-UP KIT

—CONTAINS—

Part #	O.E. #	Description
18-5311	34235	Contact Set
18-5345	33662	Condenser
18-5418	58217	Rotor
18-5385	393-9459	Distributor Cap

Delco In-Line 4 - Single Point



Display Package

18-5269
TUNE-UP KIT

—CONTAINS—

Part #	O.E. #	Description
18-5311	34235	Contact Set
18-5345	33662	Condenser
18-5418	58217	Rotor
18-5386	33765	Distributor Cap

Delco In-Line 6 - Single Point



Display Package



















18-5270
TUNE-UP KIT

—CONTAINS—

Part #	O.E. #	Description
18-5310	380543	Contact Set
18-5344	382125	Condenser
-	381711	Rotor
18-5384	383587	Distributor Cap

Delco V-8 - Single Point

① Items ending in "D" are Display Packaged - Regular number is Non-Display

 <p>18-5271 TUNE-UP KIT</p> <p>—CONTAINS—</p> <table border="1"> <thead> <tr> <th>Part #</th> <th>O.E. #</th> <th>Description</th> </tr> </thead> <tbody> <tr> <td>18-5314</td> <td>391-5090</td> <td>Contact Set</td> </tr> <tr> <td>18-5338</td> <td>391-5092</td> <td>Condenser</td> </tr> <tr> <td>18-5404-1</td> <td>391-7057, 391-5088</td> <td>Rotor</td> </tr> <tr> <td>18-5376</td> <td>391-5075</td> <td>Distributor Cap</td> </tr> </tbody> </table> <p>Mallory V-8 - Single Point - Top Terminal</p>	Part #	O.E. #	Description	18-5314	391-5090	Contact Set	18-5338	391-5092	Condenser	18-5404-1	391-7057, 391-5088	Rotor	18-5376	391-5075	Distributor Cap	 <p>18-5273 TUNE-UP KIT</p> <p>—CONTAINS—</p> <p>Replaces: 805759T3 / 805759Q3</p> <table border="1"> <thead> <tr> <th>Part #</th> <th>O.E. #</th> <th>Description</th> </tr> </thead> <tbody> <tr> <td>18-5431</td> <td>13524A5</td> <td>Rotor</td> </tr> <tr> <td>18-5395</td> <td>16457A4</td> <td>Distributor Cap</td> </tr> </tbody> </table> <p>Mercury Thunderbolt HEI - V-8</p>	Part #	O.E. #	Description	18-5431	13524A5	Rotor	18-5395	16457A4	Distributor Cap	 <p>18-5274 TUNE-UP KIT</p> <p>—CONTAINS—</p> <table border="1"> <thead> <tr> <th>Part #</th> <th>O.E. #</th> <th>Description</th> </tr> </thead> <tbody> <tr> <td>18-5432</td> <td>13524A6</td> <td>Rotor</td> </tr> <tr> <td>18-5396</td> <td>13753A2, 815407A2</td> <td>Distributor Cap</td> </tr> </tbody> </table> <p>Mercury Thunderbolt HEI - V-6</p>	Part #	O.E. #	Description	18-5432	13524A6	Rotor	18-5396	13753A2, 815407A2	Distributor Cap												
Part #	O.E. #	Description																																													
18-5314	391-5090	Contact Set																																													
18-5338	391-5092	Condenser																																													
18-5404-1	391-7057, 391-5088	Rotor																																													
18-5376	391-5075	Distributor Cap																																													
Part #	O.E. #	Description																																													
18-5431	13524A5	Rotor																																													
18-5395	16457A4	Distributor Cap																																													
Part #	O.E. #	Description																																													
18-5432	13524A6	Rotor																																													
18-5396	13753A2, 815407A2	Distributor Cap																																													
 <p>18-5275 TUNE-UP KIT</p> <p>—CONTAINS—</p> <table border="1"> <thead> <tr> <th>Part #</th> <th>O.E. #</th> <th>Description</th> </tr> </thead> <tbody> <tr> <td>18-5303</td> <td>392-6325</td> <td>Contact Set</td> </tr> <tr> <td>18-5347</td> <td>392-6324</td> <td>Condenser</td> </tr> <tr> <td>18-5403</td> <td>392-9089</td> <td>Rotor</td> </tr> <tr> <td>18-5352</td> <td>392-9766</td> <td>Distributor Cap</td> </tr> </tbody> </table> <p>Prestolite V-8 - Single Point - Screw Cap</p>	Part #	O.E. #	Description	18-5303	392-6325	Contact Set	18-5347	392-6324	Condenser	18-5403	392-9089	Rotor	18-5352	392-9766	Distributor Cap	 <p>18-5276 TUNE-UP KIT</p> <p>—CONTAINS—</p> <table border="1"> <thead> <tr> <th>Part #</th> <th>O.E. #</th> <th>Description</th> </tr> </thead> <tbody> <tr> <td>18-5303</td> <td>392-6325</td> <td>Contact Set</td> </tr> <tr> <td>18-5347</td> <td>392-6324</td> <td>Condenser</td> </tr> <tr> <td>18-5403</td> <td>392-9089</td> <td>Rotor</td> </tr> <tr> <td>18-5353</td> <td>392-9086</td> <td>Distributor Cap</td> </tr> </tbody> </table> <p>Prestolite V-6 - Single Point - Screw Cap</p>	Part #	O.E. #	Description	18-5303	392-6325	Contact Set	18-5347	392-6324	Condenser	18-5403	392-9089	Rotor	18-5353	392-9086	Distributor Cap	 <p>18-5277 TUNE-UP KIT</p> <p>—CONTAINS—</p> <table border="1"> <thead> <tr> <th>Part #</th> <th>O.E. #</th> <th>Description</th> </tr> </thead> <tbody> <tr> <td>18-5303</td> <td>392-6325</td> <td>Contact Set</td> </tr> <tr> <td>18-5347</td> <td>392-6324</td> <td>Condenser</td> </tr> <tr> <td>18-5407</td> <td>392-6326</td> <td>Rotor</td> </tr> <tr> <td>18-5369</td> <td>392-6318</td> <td>Distributor Cap</td> </tr> </tbody> </table> <p>Prestolite V-8 - Single Point - Clip Cap</p>	Part #	O.E. #	Description	18-5303	392-6325	Contact Set	18-5347	392-6324	Condenser	18-5407	392-6326	Rotor	18-5369	392-6318	Distributor Cap
Part #	O.E. #	Description																																													
18-5303	392-6325	Contact Set																																													
18-5347	392-6324	Condenser																																													
18-5403	392-9089	Rotor																																													
18-5352	392-9766	Distributor Cap																																													
Part #	O.E. #	Description																																													
18-5303	392-6325	Contact Set																																													
18-5347	392-6324	Condenser																																													
18-5403	392-9089	Rotor																																													
18-5353	392-9086	Distributor Cap																																													
Part #	O.E. #	Description																																													
18-5303	392-6325	Contact Set																																													
18-5347	392-6324	Condenser																																													
18-5407	392-6326	Rotor																																													
18-5369	392-6318	Distributor Cap																																													
 <p>18-5278 TUNE-UP KIT</p> <p>Replaces: 850484T3 Delco EST - V-6</p> <p>—CONTAINS—</p> <table border="1"> <thead> <tr> <th>Part #</th> <th>Description</th> <th>O.E. #</th> </tr> </thead> <tbody> <tr> <td>18-5362</td> <td>Distributor Cap</td> <td>850484</td> </tr> <tr> <td>18-5408</td> <td>Rotor</td> <td>850485</td> </tr> </tbody> </table>	Part #	Description	O.E. #	18-5362	Distributor Cap	850484	18-5408	Rotor	850485	 <p>18-5280 TUNE-UP KIT</p> <p>Replaces: 811635Q2 Delco EST - In-Line 4</p> <p>—CONTAINS—</p> <table border="1"> <thead> <tr> <th>Part #</th> <th>Description</th> <th>O.E. #</th> <th>Qty.</th> </tr> </thead> <tbody> <tr> <td>18-5361</td> <td>Distributor Cap</td> <td>811635, T3</td> <td>1</td> </tr> <tr> <td>18-5406</td> <td>Rotor</td> <td>811636, 1</td> <td>1</td> </tr> </tbody> </table>	Part #	Description	O.E. #	Qty.	18-5361	Distributor Cap	811635, T3	1	18-5406	Rotor	811636, 1	1	 <p>18-5281 TUNE-UP KIT</p> <p>Replaces: 808483Q2 Delco EST - V-8</p> <p>—CONTAINS—</p> <table border="1"> <thead> <tr> <th>Part #</th> <th>Description</th> <th>O.E. #</th> <th>Qty.</th> </tr> </thead> <tbody> <tr> <td>18-5354</td> <td>Distributor Cap</td> <td>808483</td> <td>1</td> </tr> <tr> <td>18-5405</td> <td>Rotor</td> <td>808484, 1, 898253010</td> <td>1</td> </tr> </tbody> </table>	Part #	Description	O.E. #	Qty.	18-5354	Distributor Cap	808483	1	18-5405	Rotor	808484, 1, 898253010	1												
Part #	Description	O.E. #																																													
18-5362	Distributor Cap	850484																																													
18-5408	Rotor	850485																																													
Part #	Description	O.E. #	Qty.																																												
18-5361	Distributor Cap	811635, T3	1																																												
18-5406	Rotor	811636, 1	1																																												
Part #	Description	O.E. #	Qty.																																												
18-5354	Distributor Cap	808483	1																																												
18-5405	Rotor	808484, 1, 898253010	1																																												
 <p>18-5282 TUNE-UP KIT</p> <p>Holley, Mercury Marine - Single Point V-8</p> <p>—CONTAINS—</p> <table border="1"> <thead> <tr> <th>Part #</th> <th>Description</th> <th>O.E. #</th> </tr> </thead> <tbody> <tr> <td>18-5389</td> <td>Dist. Cap</td> <td>393-4988T, 2</td> </tr> <tr> <td>18-5420</td> <td>Rotor</td> <td>65864, 78016</td> </tr> <tr> <td>18-5317</td> <td>Contact Set</td> <td>64850, 87-71831</td> </tr> <tr> <td>18-5346</td> <td>Condenser</td> <td>58034, 81-64851</td> </tr> </tbody> </table>	Part #	Description	O.E. #	18-5389	Dist. Cap	393-4988T, 2	18-5420	Rotor	65864, 78016	18-5317	Contact Set	64850, 87-71831	18-5346	Condenser	58034, 81-64851	 <p>18-5283 TUNE-UP KIT</p> <p>For: Mallory Single Point In-Line 4</p> <p>—CONTAINS—</p> <table border="1"> <thead> <tr> <th>Part #</th> <th>Description</th> <th>O.E. #</th> </tr> </thead> <tbody> <tr> <td>18-5397</td> <td>Distributor Cap</td> <td>-</td> </tr> <tr> <td>18-5404-1</td> <td>Rotor</td> <td>391-7057</td> </tr> <tr> <td>18-5314</td> <td>Contact Set</td> <td>391-5090</td> </tr> <tr> <td>18-5338</td> <td>Condenser</td> <td>391-5092</td> </tr> </tbody> </table>	Part #	Description	O.E. #	18-5397	Distributor Cap	-	18-5404-1	Rotor	391-7057	18-5314	Contact Set	391-5090	18-5338	Condenser	391-5092	 <p>18-5301 TUNE-UP KIT</p> <p>Fits: Male cap v-8 flamethrower distributors</p>	 <p>18-5302 TUNE-UP KIT</p> <p>Fits: Male cap v-8 flamethrower distributors</p>	 <p>18-5303 CONTACT SET</p> <p>Replaces: 392-898253005, 392-6325, 8M6001219, F16900031</p>													
Part #	Description	O.E. #																																													
18-5389	Dist. Cap	393-4988T, 2																																													
18-5420	Rotor	65864, 78016																																													
18-5317	Contact Set	64850, 87-71831																																													
18-5346	Condenser	58034, 81-64851																																													
Part #	Description	O.E. #																																													
18-5397	Distributor Cap	-																																													
18-5404-1	Rotor	391-7057																																													
18-5314	Contact Set	391-5090																																													
18-5338	Condenser	391-5092																																													
 <p>18-5310 CONTACT SET</p> <p>Replaces: 33700</p>	 <p>18-5311 CONTACT SET</p> <p>Replaces: 34235, 34235T</p>	 <p>18-5314 CONTACT SET</p> <p>Replaces: 391-5090, 391-898253004, 8M6001250</p>	 <p>18-5317 CONTACT SET</p> <p>Replaces: 64850, 87-71831</p>	 <p>18-5318 CONTACT SET</p> <p>Replaces: 58033, 898253007</p>																																											



18-5338
CONDENSER
Replaces: 391-5092, 391-898253001, 391-5093, 391-5092, 8M6001217, FI6900040



18-5344
CONDENSER
Replaces: 33706



18-5345
CONDENSER
Replaces: 33662, 898253003, 898253005, 33662Q, 6325, 8M6001218, FI6900031



18-5346
CONDENSER
Replaces: 58034, 81-64851



18-5347
CONDENSER
Replaces: 392-6324, 392-898253002, 8M6001249, FI6900023, FI6900032, FI6900083, FI6900189



18-5402
ROTOR
Replaces: 898253009
GM V-8 engines w/Delco HEI-1998 and newer (except MPI engines with 555 ECM)



18-5245
ROTOR
Replaces: 884790, 898253013
For: Late model V-6, V-8 (Alpha/Bravo 350 Mag, 5.0L, & MX 6.2L)



18-5403
ROTOR
Replaces: 392-9089, 392-9089T, 392-9767, 392-9089Q, FI6900186, FI6900190



18-5404-1
ROTOR
Replaces: 391-7057, 391-5088, 391-7057T, 391-898253029, 8M6001224, FI6901224



18-5405
ROTOR
Replaces: 808484, 808484 1, 898253010
Use with **18-5354** Distributor Cap
Fits new GM style "Module in Cap" distributors - V-8 application



18-5406
ROTOR
Replaces: 811636, 811636 1, 898253011
Use with **18-5361** Distributor Cap 3.0L LX



18-5407
ROTOR
Replaces: 392-6326, 392-6326T, FI6900044



18-5300
ROTOR
Replaces: 33707
Fits: Flamethrower Distributors



18-5408
ROTOR
Replaces: 850485, 8504851, 898253012, 8M0062084, 804424
Use with **18-5362** Distributor Cap
Fits new GM Style "Module in Cap" Distributors V6 Applications



18-5418
ROTOR
Replaces: 58217, 898253008, 58217Q



18-5420
ROTOR
Replaces: 65864, 78016



18-5431
ROTOR ASSEMBLY
Replaces: 13524A5, T1 V-8



18-5432
ROTOR ASSEMBLY
Replaces: 13524A6, 13524Q06, 13524A4, 19405A4, 90576A4 V-6



18-5243
DISTRIBUTOR CAP
Replaces: 888731, 898253T23
For: Late model V-6 (4.3L Alpha/Bravo)



18-5244
DISTRIBUTOR CAP
Replaces: 884792, 898253T22
For: Late model V-8 (Alpha/Bravo 350 Mag, 5.0L, & MX 6.2L)
Use wire set **18-8821-1**



18-5352
DISTRIBUTOR CAP
Replaces: 392-9766, 392-9766Q1, 392-9766T, FI6900185
Prestolite



18-5353
DISTRIBUTOR CAP
Replaces: 392-9086, 392-9086T



18-5354
DISTRIBUTOR CAP
Replaces: 808483, 808483T3, 804483T 804418
Fits new GM style "Module in Cap" Distributors-V-8 applications. Use **18-5405** Rotor



18-5361
DISTRIBUTOR CAP
Replaces: 811635, 811635T3
Use **18-5406** Rotor 3.0L LX



18-5362
DISTRIBUTOR CAP
Replaces: 850484, 850484T, 850484T2
Fits new GM Style "Module in Cap" Distributors - V6 Applications Use **18-5408** Rotor

 <p>18-5369 DISTRIBUTOR CAP Replaces: 392-6318, 392-6318T, FI6900184 Prestolite with gasket 18-5399</p>	 <p>18-5376 DISTRIBUTOR CAP Replaces: 391-5075, 391-5075Q1, FI6900148 Mallory</p>	 <p>18-5384 DISTRIBUTOR CAP Replaces: 33708</p>	 <p>18-5385 DISTRIBUTOR CAP Replaces: 393-9459, 393-9459Q1, 393-9459T, 33667, FI6900052</p>
 <p>18-5386 DISTRIBUTOR CAP Replaces: 33765, 33765T</p>	 <p>18-5389 DISTRIBUTOR CAP Replaces: 393-4988T, 393-4988T2, 393-4988, 393-3230</p>	 <p>18-5395 DISTRIBUTOR CAP Replaces: 16457A4, 805759T2, 805759T1, 805759A5, 805759A2, 805759A1, 90746A1, 43557A1, 43557 V-8</p>	 <p>18-5396 DISTRIBUTOR CAP Replaces: 13753A2, 815407A2 V-6</p>
 <p>18-5397 DISTRIBUTOR CAP Replaces: Mallory 9-29418 Fits: Ford 2.3L w/Mallory Distributor (87-90)</p>	 <p>18-5473 DISTRIBUTOR CAP Black Distributor Cap with Male Terminals for Flamethrower Distributors</p>	 <p>18-5474 DISTRIBUTOR CAP Red Distributor Cap with Male Terminals for Flamethrower Distributors</p>	<p>PKG OF 2</p>  <p>18-5399-9 DISTRIBUTOR CAP GASKET Replaces: 392-6329</p>

FEATURES













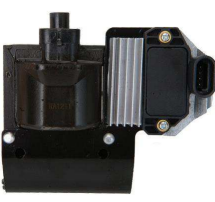





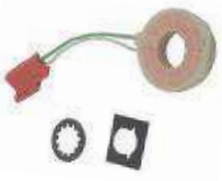

- Oil filled for better cooling and long life
- Low resistance and improved turn ratios produces the higher voltage needed to run larger spark plug gaps for added power and better fuel economy
- More windings maximize energy and reliability over the full RPM range
- Fits existing brackets for easy installation

 <p>18-5466 HI-PERFORMANCE IGNITION COIL 1.5 ohm (oil filled), black - 8 cylinder: Flame-Thrower 40,000 volt coil.</p> <ul style="list-style-type: none"> • Designed for use with the original Ignitor Electronic Conversion Kits • Can be used with other inductive ignition systems 	 <p>18-5469 HI-PERFORMANCE IGNITION COIL 3.0 ohm (oil filled), black - 4 & 6 cylinder: Flame-Thrower 40,000 volt coil.</p> <ul style="list-style-type: none"> • Designed for use with the original Ignitor Electronic Conversion Kits • Can be used with other inductive ignition systems 	 <p>18-5472 HI-PERFORMANCE IGNITION COIL 0.6 ohm (oil filled), black - 4, 6, & 8 cylinder: Flame-Thrower 45,000 volt coil.</p> <ul style="list-style-type: none"> • Super low 0.6 ohm resistance coil designed for use with the Ignitor II Hi Performance Electronic Conversion Kits • Compatible with capacitive discharge systems
--	---	--

Part No.	Description	Recommended Coil	Resistance Ohms	Part No.	Description	Recommended Coil	Resistance Ohms
18-5294	Electronic Conversion Kit	18-5469	3	18-5286	Hi Performance Electronic Conversion Kit	18-5472	0.6
18-5295	Electronic Conversion Kit	18-5469	3	18-5288	Hi Performance Electronic Conversion Kit	18-5472	0.6
18-5296-2	Electronic Conversion Kit	18-5466	1.5	18-5289	Hi Performance Electronic Conversion Kit	18-5472	0.6
18-5297	Electronic Conversion Kit	18-5469	3	18-5290	Hi Performance Electronic Conversion Kit	18-5472	0.6
18-5298	Electronic Conversion Kit	18-5466	1.5	18-5481	Flame-Thrower Distributor	18-5472	0.6
18-5299	Electronic Conversion Kit	18-5466	1.5	18-5482	Flame-Thrower Distributor	18-5472	0.6
18-5285	Hi Performance Electronic Conversion Kit	18-5472	0.6	18-5483	Flame-Thrower Distributor	18-5472	0.6

① Priced per Package

CAP APPLICATION BEGINS ON PAGE 686

 <p>18-5433 IGNITION COIL Replaces: 38547, 32193A2, 392-806529A1, 898253T24 DELCO 1115202 (Uses External Resistor)</p>	 <p>18-5438 IGNITION COIL Replaces: 392-7803A4, 392-805570A2 HEI Thunderbolt Ignition</p>	 <p>18-5465 IGNITION COIL Replaces: 392-863704T, 8M0054588 2001 and newer 4.3L, 5.0L, 5.7L & 6.2L with 555 ECM (OM300000 and up)</p>	 <p>18-7493 COIL Replaces: 392889925 For: 8.1L & 496 Mag OM315053 & UP</p>	 <p>18-7648 IGNITION COIL Replaces: 392-881732</p>
 <p>18-5442 IGNITION COIL Replaces: 806673T, T1</p>	 <p>18-5443 IGNITION COIL Replaces: 817378T, 817378, 898253T27</p>	 <p>18-5117 IGNITION MODULE Replaces: GM 10482803 Fits: MCM MIE 4.3L MPI, 5.0L MPI, 350 Mag MPI and MX 6.2L MPI engines with ECM555 (2001 & Up) S/N OM300000 & Up</p>	 <p>18-5107-1 IGNITION MODULE 4/6/8 cyl. Replaces: 811637001, 811637002, 811637T, 811637, 850487, 804412, 802464 Delco EST</p>	 <p>18-5464 IGNITION MODULE Fits: Sierra 18-5481, 18-5482 and 18-5483 Billet HI-PERFORMANCE ELECTRONIC DISTRIBUTORS (except HEI/EST)</p>
 <p>18-5488 IGNITION MODULE Replacement module for Mallory electronic distributors</p>	 <p>18-5108 PICK-UP COIL SENSOR Replaces: 811639, T V4/V6/V8 Delco EST</p>	 <p>18-5493 IGNITION PICKUP COIL ASSEMBLY Replacement pick-up coil for Accel Electronic Distributors</p>	 <p>18-5116-1 IGNITION SENSOR KIT Replaces: 87-861780A2, Q4, 87-892150A02 For: V-6 & V-8 with Thunderbolt ignition (1981-1997) nut connectors</p>	 <p>18-7556 CRANKSHAFT SENSOR Replaces: 864297001 Fits: Mercury 5.0L, 6.2L 1998-2010</p>
 <p>18-7642 PICK-UP ASSEMBLY Replaces: 898141 Fits: Engines equipped w/ Delco HVS distributor</p>	 <p>18-26810 GM HEI 4 TERMINAL PIGTAIL Fits: GM HEI Distributors w/4 terminals</p>	 <p>18-26811 GM HEI 2 TERMINAL PIGTAIL Fits: GM HEI Distributors w/2 terminals</p>	 <p>18-26812 HEI COIL GRAY CONNECTOR</p>	 <p>18-26813 HEI COIL BLACK CONNECTOR</p>
 <p>18-61051 SCREW KIT (4 PER PKG) Fits: Mercruiser V6 & V8 Thunderbolt Distributor Caps</p>	<div style="display: flex; justify-content: space-between;"> <div data-bbox="414 1780 646 1848"> <p>Ignitor® II ELECTRONIC IGNITION</p> </div> <div data-bbox="869 1780 1077 1825"> <p>FEATURES</p> </div> </div> <ul style="list-style-type: none"> • Senses current levels in the coil & adjusts the dwell to maintain peak energy throughout entire RPM range. • Develops, on average, 4 times more available energy between 3000 and 5000 RPM's and twice as much plug voltage as point-type systems. • Ignition energy is sustained and coil life is increased when peak current level is reached just prior to spark. • More stable timing. • Use with 18-5472 "Flame Thrower II" Coil for optimum performance 			



18-5285
HI-PERFORMANCE ELECTRONIC CONVERSION KIT
 Fits: 4 Cylinder Delco Distributors



18-5286
HI-PERFORMANCE ELECTRONIC CONVERSION KIT
 Fits: 6 Cylinder Delco Distributors



18-5288
HI-PERFORMANCE ELECTRONIC CONVERSION KIT
 Fits: Most Prestolite V-8 Distributors with snap down cap



18-5289
HI-PERFORMANCE ELECTRONIC CONVERSION KIT
 Fits: Most Prestolite Distributors with screw down cap



18-5290
HI-PERFORMANCE ELECTRONIC CONVERSION KIT
 Fits: Most Mallory YL or YD 8 cylinder Distributors with clockwise and counter clockwise rotation



FEATURES

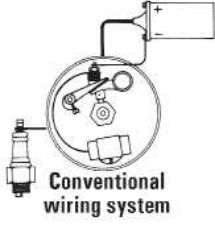

Conventional wiring system

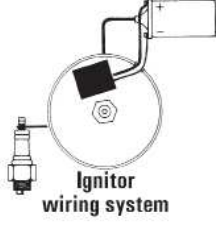

Ignitor wiring system

- Replaces point & condensers for true solid state ignition.
- Uses standard coil, cap and rotor.
- Easy to install, one-piece, 2-wire hook-up.
- Accurate to within 1/4° timing accuracy 0 to 6000 RPM range.
- Can be used with Flame Thrower [18-5466](#) & [18-5469](#).



18-5294
ELECTRONIC CONVERSION KIT
 Fits: 6 Cyl. Delco Distributors



18-5295
ELECTRONIC CONVERSION KIT
 Fits: Most 4 Cyl. Prestolite Distributors (Except IBM7026)
 For: Onan, Universal, Waukesha, Wisconsin



18-5296-2D Display Package
ELECTRONIC CONVERSION KIT
 Fits: Most Mallory YL or YD 8 cyl. Distributors with clockwise or counter clockwise rotation



18-5297D Display Package
ELECTRONIC CONVERSION KIT
 For: 4 Cyl. GM



18-5298
ELECTRONIC CONVERSION KIT
 (with snap down cap)
 For: Most Prestolite V-8 Distributors



18-5299D Display Package
ELECTRONIC CONVERSION KIT
 (with screw down cap)
 For: Most Prestolite V-8 Distributors
 Use with [18-5403](#) Style Rotor

APPLICATION BEGINS ON PAGE 686
 ① Items ending in "D" are Display Packaged - Regular number is Non-Display



FEATURES

- Distributors feature the Ignitor II ignition module with adaptive dwell control adjusts the spark timing over the entire RPM range to maximize performance
- Upper roller bearing and oil impregnated bronze sintered bottom bushing are installed and aligned bored for accuracy for maximum durability
- Machined heat treated gear with tight tolerances insures durability and consistent timing to maximize horsepower and performance. Complete with high dielectric strength cap and rotor for years of performance

Standard Rotation

CCW Rotation

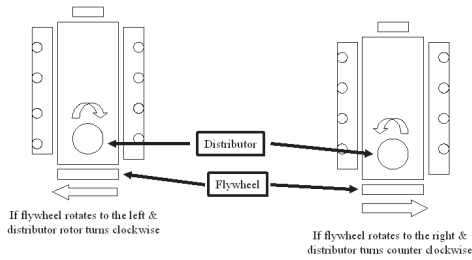

18-5481
HI-PERFORMANCE ELECTRONIC DISTRIBUTOR
 Fits: Ford V-8 351 Windsor
 Replacement cap/rotor kit: [18-5266](#)



18-5482
HI-PERFORMANCE ELECTRONIC DISTRIBUTOR
 Fits: Ford V-8 351 Cleveland, 351M, 400, 429 and 460 engines
 Replacement cap/rotor kit: [18-5266](#)



18-5483
HI-PERFORMANCE ELECTRONIC DISTRIBUTOR
 Fits: Chevrolet marine small and big block engines (standard deck height)
 Replacement cap/rotor kit: [18-5266](#)

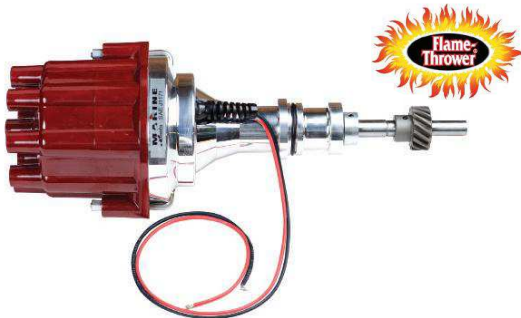

18-5477
ELECTRONIC DISTRIBUTOR
 Fits: Ford 302 V-8 engines
 Replacement Cap/Rotor Kit [18-5266](#)

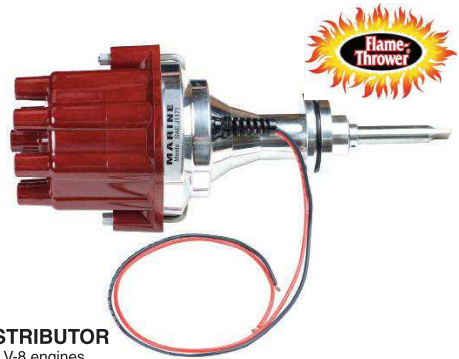

18-5478
ELECTRONIC DISTRIBUTOR
 Fits: Chrysler LA series V-8 engines
 Replacement Cap/Rotor Kit [18-5266](#)



18-5479
ELECTRONIC DISTRIBUTOR
 Fits: GM V-8 engines-reverse rotation
 Replacement Cap/Rotor Kit [18-5266](#)



18-5480
COMPLETE IGNITION CONVERSION KIT
 Fits: GM SB & BB with Standard Deck Height
 —CONTAINS—

Part #	Description
18-5472	Coil
18-8803-2	Wire Set
18-5483	Distributor

APPLICATION BEGINS ON PAGE 686



18-26002-1
IGNITION SYSTEM KIT
 Fits: GM 4.3L/262 CID Even Fire Engines

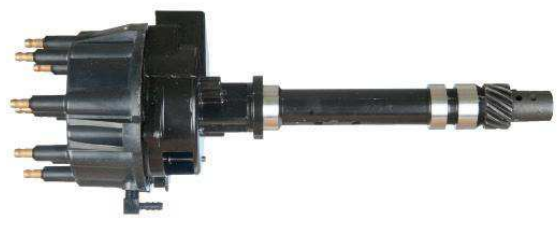

18-5470
THUNDERBOLT IV V-8 DISTRIBUTOR
 Replaces: 805185A36
 Fits: GM V-8 engines
 Tune-Up Kit **18-5273**



18-5471
THUNDERBOLT IV V-6 DISTRIBUTOR
 Replaces: 805185A37
 GM V-6 engines
 Tune-Up Kit **18-5274**



18-5350
DISTRIBUTOR
 Replaces: 888751A03, 888751A02, 888751A1
 Fits: Vortec V-6 4.3L MPI (2002-UP) (S/N OM300000 and UP)



18-5351
DISTRIBUTOR
 Replaces: 884794A02, 884794A1
 Fits: Vortec V-8 2001 and up 5.0L/ 5.7L/ 6.2L MPI engines (S/N OM300000 and up)



18-5475
DISTRIBUTOR
 Replaces: 817377, 817377T
 Fits: 4 Cyl. GM w/ Delco EST Ignition
 Tune-Up Kit **18-5280**



18-5476
DISTRIBUTOR
 Replaces: 807964A1, 907964A1
 Fits: GM V-6 engines with Delco EST ignition HEI
 Tune-Up Kit **18-5278**



18-5484-1
ELECTRONIC DISTRIBUTOR
 Conventional Rotation
 Replaces: 805222A1
 Late Model HEI
 For: V8 — 262-454 & 502 except 384/ 409 and tall block engines
 • Designed as a plug-in replacement for GM-style fuel injection system distributors

—CONTAINS—	
Description	Part #
Distributor Cap	18-5354
Rotor	18-5405

Tune-Up Kit **18-5281**



18-26111-1
DISTRIBUTOR
 Replaces: Mallory YL648AV
 Fits: Mercruiser 3.7L L4/LH



18-5486-2
ELECTRONIC DISTRIBUTOR
 Conventional Rotation
 For: Chevrolet L4, 153 & 181 CID

—CONTAINS—	
Part #	Description
18-5397	Distributor Cap
18-5488	Module
18-5404-1	Rotor

18-5487-2
ELECTRONIC DISTRIBUTOR

Conventional Rotation
Replaces: 9-26309, Mallory YLM676AV
For: GM L6, 194, 230, 250, 292 CID

—CONTAINS—

Part #	Description
18-5488	Module
18-5404-1	Rotor



18-5489-2
ELECTRONIC DISTRIBUTOR
Conventional Rotation

For: Ford V8 351W CID

—CONTAINS—

Part #	Description
18-5376	Distributor Cap
18-5488	Module
18-5404-1	Rotor



18-5494-2
ELECTRONIC DISTRIBUTOR
Conventional Rotation

For: Chevrolet all V8 includes 482, 502, 540 CID (Except 348,409 & Tall Deck Big Block)

—CONTAINS—

Part #	Description
18-5376	Distributor Cap
18-5488	Module
18-5404-1	Rotor



18-5495-2
ELECTRONIC DISTRIBUTOR
Conventional Rotation

For: Ford V8 302 CID

—CONTAINS—

Part #	Description
18-5376	Distributor Cap
18-5488	Module
18-5404-1	Rotor



18-5496-2
ELECTRONIC DISTRIBUTOR

Replaces: YLM567CV
Conventional Rotation
For: Ford V8 351C — 460 CID

—CONTAINS—

Part #	Description
18-5376	Distributor Cap
18-5488	Module
18-5404-1	Rotor



18-5497-2
ELECTRONIC DISTRIBUTOR

Replaces: YLM579AV
Conventional Rotation
For: Chrysler V8 273,318 (67 & UP) 340, 360 CID "LA" engines

—CONTAINS—

Part #	Description
18-5376	Distributor Cap
18-5488	Module
18-5404-1	Rotor



18-5309-1
DISTRIBUTOR
Contact Controlled (Standard Rotation)

Replaces: Mallory YL512CV
For: Most Ford 302 CID V-8 Eng.
Tune-Up Kit 18-5251

—CONTAINS—

Part #	Description
18-5314	Contact Set
18-5338	Condenser
18-5404-1	Rotor



18-5312-1
DISTRIBUTOR (Contact Controlled)

Replaces: Mallory YL554CV
For: Most Ford 351 CID V-8 Eng.
Tune-Up Kit 18-5251

—CONTAINS—

Part #	Description
18-5314	Contact Set
18-5338	Condenser
18-5404-1	Rotor



18-5313-1
DISTRIBUTOR
Contact Controlled (Standard Rotation)

Replaces: 17177A1, 91823A3, 816148A1, 74905A3, 68521A4, 68521A3, 13447A1
Mallory YL624AV
For: Most GM V-8 Engs. (small & large blocks) Mallory Tall Cap
Tune-Up Kit 18-5251

—CONTAINS—

Part #	Description
18-5314	Contact Set
18-5338	Condenser
18-5404-1	Rotor



18-5315-1
DISTRIBUTOR
Contact Controlled (Standard Rotation)

Replaces: 87581, 87581T, 62424, 58231, 52352, 33266, 195141
Mallory YL673AV
For: Most GM 4 Cyl. Engs. (120 & 140 HP)
Tune-Up Kit 18-5251

—CONTAINS—

Part #	Description
18-5314	Contact Set
18-5338	Condenser
18-5404-1	Rotor





18-5498-2
ELECTRONIC DISTRIBUTOR
Replaces: 9-26307; Mallory YLM624BV
For: GM V8, 482, 502, 540 CID (Except 348, 409 & Tall Deck Big Block) (Reverse Rotation)



18-5316-1
DISTRIBUTOR
Replaces: Mallory YL624BV
Fits: Most GM V8 (Reverse Rotation)



18-5339-1
DISTRIBUTOR
Replaces: 9-26103; Mallory YL566AV
For: GM V8 327



18-26110-1
DISTRIBUTOR
Replaces: 9-26110; Mallory YL579AV
For: Chrysler V8, 273, 318 (1967 & Up), 340 and 360 "LA" Engines



18-26104-1
DISTRIBUTOR
Replaces: 9-26104; Mallory YL567EV
For: Ford V8 351C



18-26112-1
DISTRIBUTOR
Replaces: 9-26112; Mallory YL676AV
Fits: GM L6, 194, 230, 250, 292 CID (Conventional Rotation)



18-5512
I/L 4 DELCO EST CONVERSION KIT
Description: Converts 4 Cylinder GM Engines to Electronic
Includes: Distributor, Coil, Ignition Wires, and Harnesses



18-5513
V-6 DELCO EST CONVERSION KIT
Description: Converts 6 Cylinder GM Engines to Electronic
Includes: Distributor, Coil, Ignition Wires, and Harnesses



18-5514
V-8 DELCO EST CONVERSION KIT
Description: Converts 8 Cylinder GM Engines to Electronic
Includes: Distributor, Coil, Ignition Wires, and Harnesses



18-5518
I/L 4 SIERRA ELECTRONIC DISTRIBUTOR CONVERSION KIT
Description: Converts 4 Cylinder GM Engines to Electronic
Includes: Distributor, Coil, Ignition Wires, and Harnesses



18-5519
I/L 6 SIERRA ELECTRONIC DISTRIBUTOR CONVERSION KIT
Description: Converts 6 Cylinder GM Engines to Electronic
Includes: Distributor, Coil, Ignition Wires, and Harnesses



18-5520
V-8 SIERRA ELECTRONIC DISTRIBUTOR CONVERSION KIT
Description: Converts 8 Cylinder GM Engines to Electronic
Includes: Distributor, Coil, Ignition Wires, and Harnesses

APPLICATION BEGINS ON NEXT PAGE

MODEL	Cyl.	Ignition Type	Year	Serial #	Tune-Up Kit	Contact Set	Rotor	Dist. Cap	Coil	Distributor	Spark Plug Wires
110	153/4	⊗	1963-1966	1537370-2044033	18-5250 ★	18-5311	18-5418	18-5385	18-5433	18-5315-1	18-8800-1
					18-5268 ☞						
120	153/L4	⊗	1964-1986	1666601 - B531853	18-5250 ★	18-5311	18-5418	18-5385	18-5433	18-5315-1	18-8800-1
					18-5268 ☞						
2.5L	153/L4	⊗	1987-1989	B531854 - C853255	18-5250	18-5311			18-5433		
PRESTOLITE REPLC IGN	4 CYL	⊗	1963-1989	1537370 - C853255		18-5303	18-5403				
140	181/L4	⊗	1968-1986	2508261 - B450800	18-5250 ★	18-5311	18-5418	18-5385	18-5433	18-5315-1	18-8800-1
					18-5268 ☞						
3.0L	181/L4	⊗	1987-1989	B450801 - C856558	18-5250	18-5311			18-5433		
3.0L	181/L4	⊗	1990-1991	C856559 - D504541		18-5303	18-5403		18-5433		
3.0L	181/L4	⊕	1990-1991	C856559 - D504541							18-8811-1
3.0L	181/L4	⊗	1991-1994	D504542 - F603999				18-5361	18-5443		18-8833-1
3.0L	181/L4	⊗	1998-2010	L010042 - & UP				18-5361	18-5443		18-8833-1
3.0L MPI	181/L4	⊗	2008-2010	A072812 - & UP				18-5361	18-5443		18-8833-1
3.0LX	181/L4	⊕	1990-1991	C856559 - D504541							18-8811-1
3.0LX	181/L4	⊗	1991-1997	D504542 - K999999				18-5361	18-5443		18-8833-1
3.0L/ LX	L4		1990-1995	C856559 - F603999	18-5262	18-5303	18-5403		18-5433	18-5315-1	18-8800-1
3.0L/ LX	L4		1990-1995	C856559 - F603999							18-8811-1
3.0L/LX	L4		1996 & UP	F604000 & Up	18-5280		18-5406	18-5361	18-5443		18-8833-1
PRESTOLITE REPLC IGN	4 CYL	⊗	1968-1991	2508261 - D504541		18-5303	18-5403				
165	224/L4	⊗	1987	B434941 - B774251	18-5250	18-5311			18-5433		
170	224/L4	⊗	1985-1986	6916779 - B434940	18-5250	18-5311			18-5433		
180	224/L4	⊗	1987	B436391 - B775248	18-5250	18-5311			18-5433		
180	224/L4	⊗	1987-1989	B436391 - B775248		18-5303	18-5403		18-5433		
190	224/L4	⊗	1985-1986	6916779 - B436390	18-5250	18-5311			18-5433		
3.7L	224/L4	⊗	1988-1989	B774252 - & UP	18-5250	18-5311			18-5433		
3.7LX	224/L4	⊗	1988-1989	B775249 - & UP	18-5250	18-5311			18-5433		
3.7LX	224/L4	⊗	1988-1989	B775249 - & UP		18-5303	18-5403		18-5433		
470	224/L4	⊗	1976-1984	4208730 - 6916778	18-5250 ★	18-5311	18-5418	18-5385	18-5433		18-8808-2
165, 170, 190 (224CID)	L4		1985-1989	6916779 & UP	18-5250 ★	18-5311	18-5418	18-5385	18-5433		18-8808-2
					18-5268 ☞						
180LX	L4		1987-1989	B436391 & UP	18-5250 ★	18-5311	18-5418	18-5385	18-5433		18-8808-2
					18-5268 ☞						
180LX	L4		1987-1989	B436391 & UP	18-5262	18-5303	18-5403		18-5433		18-8808-2
160, 165(250cid)	L6		1967-1981	2048022-5813433	18-5250 ★	18-5311	18-5418	18-5386	18-5433		18-8809-1
					18-5269 ☞						
485	224/L4	⊗	1980-1982	5685394 - 6218036	18-5250	18-5311			18-5433		
488	224/L4	⊗	1983-1984	6170297 - 6916778	18-5250	18-5311			18-5433		
PRESTOLITE REPLC IGN	4 CYL	⊗	2010			18-5303	18-5403				
140	194/L6	⊗	1963	1538930 - 1725960	18-5250 ★	18-5311	18-5418	18-5386		18-5312-1	18-8809-1
					18-5269 ☞						
150	230/L6	⊗	1964-1966	1666495 - 2048046	18-5250 ★	18-5311	18-5418	18-5386			18-8809-1
					18-5269 ☞						
160	250/L6	⊗	1967-1970	2048022 - 2771483	18-5250	18-5311		18-5386	18-5433		
165	250/L6	⊗	1971-1981	2771484 - 5813433	18-5250	18-5311		18-5386	18-5433		
200	292/L6	⊗	1969	2453769 - 2712072	18-5250 ★	18-5311	18-5418	18-5386	18-5433	18-5487-2	18-8809-1
					18-5269 ☞						
PRESTOLITE REPLC IGN	6 CYL	⊗	2010			18-5303	18-5403	18-5353	18-5433		
185 (4 bbl)	229/V-6	⊗	1983-1984	6330183 - 6919655	18-5262 ★	18-5303	18-5403	18-5353	18-5433		18-8801-1
					18-5276 ☞						
175	262/V-6	⊗	1987	B527955 - B773242			18-5432	18-5396	18-5438		
175, 185, 4.3	262/V-6		1985-1993	6919656 - F000877	18-5274		18-5432	18-5396	18-5438		18-8810-1
185 (2bbl)	262/V-6	⊗	1985-1987	6919656 - B527954			18-5432	18-5396	18-5438		

- ⊗ Mallory Ignition
- ⊗ Prestolite
- ⊗ Autolite
- ⊗ Mercury Ignition
- ⊗ Holley
- ⊗ Thunderbolt IV
- ⊗ With screw down cap
- ⊗ Delco
- ⊗ Electronic dist. (std rotation) excluding Thunderbolt ignition
- ⊗ Delco EST
- ⊕ Delco digital system
- ★ With out dist cap
- ☞ With dist cap
- ☛ Mercury HEI
- ☛ Delco HEI
- ♣ Thunderbolt V
- ♣ Prestolite with clip down dist cap
- ⊕ Contact controlled dist. (Std. Rotation) excl. Thunderbolt ign.

MODEL	Cyl.	Ignition Type	Year	Serial #	Tune-Up Kit	Contact Set	Rotor	Dist. Cap	Coil	Distributor	Spark Plug Wires
205	262/V-6	⊕	1985-1987	A331455 - B775129			18-5432	18-5396	18-5438		
205, 4.3LX 4bbl	262/V-6		1985-1996	A331455 - F802999	18-5274		18-5432	18-5396	18-5438		18-8810-1
262 TBI (GEN +)	262/V-6	⊕	1996-1997	F803800 - K999999					18-5443		18-8835-1
4.3L (2bbl)	262/V-6	⊕	1988-1996	B773243 - F802999			18-5432	18-5396	18-5438		
4.3L (2bbl) (GEN +)	262/V-6	⊕	1998-2010	L010044 & UP			18-5432	18-5396			
4.3L EFI (GEN +) (TBI)	262/V-6	⊕	1998	L012009 - L359999					18-5438		18-8835-1
4.3L EFI (GEN +) (TBI)	262/V-6	⊕	1999-2001	L360000 - M299999			18-5432	18-5396	18-5438		
4.3L MPI	262/V-6	⊕	2002-2010	M300000 & UP	18-5246		18-5245	18-5243	18-5465	18-5350	18-8829-1
4.3LH (GEN +) (4bbl)	262/V-6	⊕	1998-2002	L010044 - M614999			18-5432	18-5396	18-5438		
4.3LX (4bbl)	262/V-6	⊕	1988-1996	B775130 - F802999			18-5432	18-5396	18-5438		
4.3LX (GEN +) (2bbl)	262/V-6	⊕	1996-1997	F803000 - K999999			18-5432	18-5396	18-5438		
4.3L/LH/LX/LXH	V6		1996-2001	F803000 & UP	18-5274		18-5432	18-5396	18-5438		18-8810-1
Alpha(Gen+)											
4.3L/LH/LX/LXH	V6		1996-2001	F803000 & UP	18-5274		18-5432	18-5396	18-5438		18-8810-1
Bravo(Gen+)											
4.3L EFI,262	V6		1996-1998	F803000- L359999	18-5278		18-5408	18-5362	18-5443		18-8810-1
Mag(TBI)(Gen+)											
4.3L EFI(TBI)	V6		1996 & up	L012009 - L359999	18-5278		18-5408	18-5362	18-5443	18-5476	18-8835-1
(Gen+)				L360000 & UP	18-5274		18-5432	18-5396	18-5438		18-8835-1
4.3L EFI(TBI)	V6		1999-2001	L360000 & UP	18-5274		18-5432	18-5396	18-5438		18-8810-1
215 MCM & MIE (FORD)	302/V-8	⊕	1970-1972	2781153 - 3563181	18-5253 ★	18-5318	18-5402	18-5389	18-5433	18-5495-2 ⊕	18-8803-2
					18-5267 ☐					18-5309-1 ⊕	
215 MCM & MIE (FORD)	302/V-8	⊕	1970-1972	2781153 - 3563181	18-5251 ★	18-5314	18-5404-1	18-5376	18-5433	18-5495-2 ⊕	18-8803-2
					18-5271 ☐					18-5309-1 ⊕	
225 MCM & MIE (FORD)	302/V-8	⊕	1973-1974	3385721 - 4166999	18-5253 ★	18-5318	18-5420	18-5389	18-5433	18-5495-2 ⊕	18-8803-2
Ford(302cid)					18-5267 ☐					18-5309-1 ⊕	
225 MCM & MIE (FORD)	302/V-8	⊕	1973-1974	3385721 - 4166999	18-5251 ★	18-5314	18-5404-1	18-5376	18-5433	18-5495-2 ⊕	18-8803-2
					18-5271 ☐					18-5309-1 ⊕	
225 MCM & MIE (FORD)	302/V-8	⊕	1973-1974	3385721 - 4166999	18-5254 ★	18-5317	18-5420	18-5389	18-5433	18-5495-2 ⊕	18-8803-2
					18-5267 ☐					18-5309-1 ⊕	
888 (FORD)	302/V-8	⊕	1971-1977	3108723 - 4887829	18-5254	18-5317	18-5420	18-5389	18-5433	18-5495-2 ⊕	18-8803-2
										18-5309-1 ⊕	
888 (FORD)	302/V-8	⊕	1971-1977	3108723 - 4887829	18-5253	18-5318	18-5420	18-5389	18-5433	18-5495-2 ⊕	18-8803-2
888 (FORD)	302/V-8	⊕	1971-1977	3108723 - 4887829	18-5258 ★	18-5303	18-5407	18-5369	18-5433	18-5495-2 ⊕	
					18-5277 ☐					18-5309-1 ⊕	18-8803-2
888 (FORD)	302/V-8	⊕	1971-1977	3108723 - 4887829	18-5251 ★	18-5314	18-5404-1	18-5376	18-5433	18-5495-2 ⊕	
					18-5271 ☐					18-5309-1 ⊕	18-8803-2
190 (GM 283)	283/V-8	⊕	1963-1964	1564539 - 1730903	18-5252	18-5310	18-5417	18-5384	18-5438	18-5498-1 ⊕	
										18-5494-2 ⊕	
										18-5313-1 ⊕	
198 MIE	305/V-8	⊕	1977	4776402 - 4931099		18-5314	18-5404-1		18-5433		
200 (5.0L)	305/V-8	⊕	1985-1995	6899058 - F600999			18-5431	18-5395	18-5438		
228	305/V-8	⊕	1977-1982	4765100 - 6218461		18-5314	18-5401-1		18-5433		
228	305/V-8	⊕	1982-1984	6218462 - 6899268			18-5431	18-5395	18-5438		
228 MIE	305/V-8	⊕	1977-1980	4765100 - 5907057		18-5314	18-5401-1		18-5433		
228 MCM & MIE	305/V-8		1977-1984	4765100 - 6218461	18-5251 ★	18-5314	18-5404-1	18-5376	18-5433		18-8803-2
					18-5271 ☐					18-5498-1 ⊕	
228	305/V-8		1985-1986	6218462 - 6899268	18-5273		18-5431	18-5395	18-5438	18-5494-2 ⊕	18-8804-1
										18-5498-1 ⊕	
230, 5.0L/LX MIE	305/V-8		1981-1995	5907058 - F600999	18-5273		18-5431	18-5395	18-5438	18-5494-2 ⊕	18-8804-1
										18-5498-1 ⊕	
198, 898 MCM &	305/V-8		1977-1982	4776402 - 6218461	18-5251 ★	18-5314	18-5404-1	18-5376	18-5433	18-5494-2 ⊕	18-8803-2
					18-5271 ☐					18-5498-1 ⊕	
230	305/V-8	⊕	1985-1987	6899269 - MB773739			18-5431	18-5395	18-5438		

- ⊕ Mallory Ignition
- ⊕ Prestolite
- ⊕ Autolite
- ⊕ Mercury Ignition
- ⊕ Holley
- ⊕ Thunderbolt IV

- ⊕ With screw down cap
- ⊕ Delco
- ⊕ Electronic dist. (std rotation) excluding Thunderbolt ignition
- ⊕ Delco EST
- ⊕ Delco digital system
- ★ With out dist cap

- ☐ With dist cap
- ☐ Mercury HEI
- ☐ Delco HEI
- ⬆ Thunderbolt V
- ⬇ Prestolite with clip down dist cap
- ⊕ Contact controlled dist. (Std. Rotation) excl. Thunderbolt ign.

MODEL	Cyl.	Ignition Type	Year	Serial #	Tune-Up Kit	Contact Set	Rotor	Dist. Cap	Coil	Distributor	Spark Plug Wires
230 MIE	305/V-8	⊙	1981-1987	5907058 - B788151			18-5431	18-5395	18-5438		
5.0L (GEN +)	305/V-8	♣	1998-2010	L015751 & UP			18-5431	18-5395	18-5438		
5.0L EFI (Gen+)	305/V-8	⊙	1998	L012052 - L331630	18-5281		18-5405	18-5354	18-5442	18-5494-2 ⊙	18-8836-1
										18-5498-1 ⊙	
5.0L EFI (GEN +)	305/V-8	⊙	1998	L331651 - L339999					18-5442		
5.0L EFI (GEN +)	305/V-8	⊙	1999	L331631 - L331650			18-5431		18-5438		
5.0L MPI	305/V-8	⊙	2002-2010	M300000 & UP							18-8828-1
5.0L MIE	305/V-8	⊙	1988	B788152 - C396832			18-5431	18-5395	18-5438		
5.0LX	305/V-8	⊙	1988-1995	B773740 - F600999			18-5431	18-5395			
898	305/V-8	⊙	1977-1982	4762210 - 621461		18-5314	18-5404-1		18-5433		
898	305/V-8	⊙	1983-1984	6218462 - 6899057			18-5431	18-5395	18-5438		
350MAG MPI	V8		1998-2001	L302200 & UP	18-5273		18-5431	18-5395	18-5438	18-5494-2	
(Gen+) &										18-5498-1	
MIE(Gen+)											
350 MAG MPI	V8		2001-2004	M300000 & UP	18-5247		18-5245	18-5244	18-5465	18-5351	
350 MAG MPI					18-5247		18-5245	18-5244			
HORIZON											
350 MAG	V8		1999-2001	L304700 & UP	18-5273		18-5431	18-5395	18-5438	18-5494-2	
HORIZON MIE										18-5498-1	
350 MAG HORIZON	V8		2001-2004	M300000 & Up	18-5247		18-5245	18-5244	18-5465	18-5351	
MIE											
350MAG MPI	V8		1999-2001	L304600 & up	18-5273		18-5431	18-5395	18-5438	18-5494-2	
SKI(Gen+)										18-5498-1	
350MAG SKI	V8		1991-1996	D505450 - K040399	18-5273		18-5431	18-5395	18-5438	18-5494-2	
										18-5498-1	
350MAG SKI	V8		1991-1996	D505450 - K040399	18-5273		18-5431	18-5395	18-5438	18-5494-2	
										18-5498-1	
350MAG SKI	V8		1991-1997	D505450 - K999999	18-5273		18-5431	18-5395	18-5438	18-5494-2	
										18-5498-1	
225 (GM)	327/V-8	⊙	1963-1969	1539620 - 2694014	18-5252 ★	18-5310	18-5417	18-5384	18-5433	18-5494-2 ⊙	18-8803-2
					18-5270 ☞					18-5498-1 ⊙	
										18-5313-1 ⚡	
225 MIE (GM)	327/V-8	♣	1968	2278647 - 2694014	18-5282		18-5420	18-5389		18-5494-2 ⊙	18-8803-2
										18-5498-1 ⊙	
250 MCM & MIE	327/V-8	♣	1968-1969	2314301 - 2639854	18-5282		18-5420	18-5389		18-5494-2 ⊙	18-8803-2
										18-5498-1 ⊙	
250	350/V-8	⊙	1977	4768000 - 4908849	18-5251 ★	18-5314	18-5404-1	18-5376	18-5433	18-5494-2 ⊙	18-8803-2
					18-5271 ☞					18-5498-1 ⊙	
250 MCM & MIE (GM)	350/V-8	⊙	1975-1976	3258728 - 4521254		18-5317	18-5420	18-5389	18-5433		
255 MCM (GM)	350/V-8	⊙	1976	4498701 - 4767999		18-5314	18-5404-1		18-5433		
255 MIE	350/V-8	⊙	1976-1980	4498701 - 5907057		18-5314	18-5404-1				
260	350/V-8	⊙	1978-1982	4908850 - 6218461		18-5314	18-5404-1		18-5433		
270 MCM & MIE	350/V-8	♣	1969-1972	2851074 - 3385720	18-5282		18-5420	18-5389	332- 4895A 8	18-5494-2 ⊙	18-8803-2
										18-5498-1 ⊙	
280 TRS	350/V-8	⊙	1975	4176250 - 4499390		18-5317	18-5420	18-5389	18-5433		
280 TRS	350/V-8	⊙	1976	4499391 - 4770199	18-5251 ★	18-5314	18-5404-1	18-5376	18-5433	18-5494-2 ⊙	18-8803-2
					18-5271 ☞					18-5498-1 ⊙	
										18-5313-1 ⚡	
300	350/V-8	⊙	1985-1986	6668677 - B430367			18-5431	18-5395	18-5438		
320 EFI	350/V-8	⊙	1987-1989	A543604 - C622418			18-5431	18-5395	18-5438		
350 MAG ALPHA	350/V-8	⊙, ♣	1986-1997	A635178 - K999999			18-5431	18-5395	18-5438		
350 MAG ALPHA EFI (GEN +)	350/V-8	⊙	1996-1997	F800300 - K999999	18-5281		18-5405	18-5354	18-5442	18-5494-2 ⊙	18-8836-1
350 MAG BRAVO MPI	350/V-8	⊙	1995-1997	F415189 - K999999				18-5354	18-5443	18-5498-1 ⊙	18-8836-1
350 MAG EFI SKI	350/V-8	⊙	1994-1997	F215561 - K999999				18-5354	18-5443		18-8832-1

- ⊙ Mallory Ignition
- ⊙ Prestolite
- ⊙ Autolite
- ⊙ Mercury Ignition
- ⊙ Holley
- ⊙ Thunderbolt IV

- ⊙ With screw down cap
- ⊙ Delco
- ⊙ Electronic dist. (std rotation) excluding Thunderbolt ignition
- ⊙ Delco EST
- ♣ Delco digital system
- ★ With out dist cap

- ☞ With dist cap
- ♣ Mercury HEI
- ⊙ Delco HEI
- ♣ Thunderbolt V
- ♥ Prestolite with clip down dist cap
- ⚡ Contact controlled dist. (Std. Rotation) excl. Thunderbolt ign.

MODEL	Cyl.	Ignition Type	Year	Serial #	Tune-Up Kit	Contact Set	Rotor	Dist. Cap	Distributor	Spark Plug Wires	
350 MAG MPI (GEN +)	350/V-8	EST	1998	L010019 - L325962	18-5281		18-5405	18-5354	18-5442	18-5494-2 Ⓣ	18-8832-1
										18-5498-1 Ⓣ	
350 MAG MPI (GEN +)	350/V-8	☛	1999-2001	L325953 - M999999			18-5431	18-5395	18-5438		
350 MAG MPI	350/V-8	EST	2002-2010	M300000 & UP				18-5244			18-8828-1
350 MAG MPI HORIZON	350/V-8	EST	2002-2007	M300000 - A299999				18-5244			
350 MAG MPI HORIZON MIE	350/V-8	☛	1999-2001	L304700 - M299999			18-5431	18-5395	18-5438		
350 MAG MPI HORIZON MIE	350/V-8	EST	2002-2007	M300000 - A089999				18-5244			
350 MAG MPI MIE (GEN +)	350/V-8	EST	1998	L002008 - L302199	18-5281		18-5405	18-5354	18-5443	18-5494-2 Ⓣ	18-8832-1
										18-5498-1 Ⓣ	
350 MAG MPI MIE (GEN +)	350/V-8	☛	1998-2001	L302200 - M299999	18-5273		18-5431	18-5395	18-5438		18-8834-1
350 MAG MPI MIE	350/V-8	EST	2002-2007	M300000 - A089999				18-5244			18-8828-1
350 MAG MPI SKI	350/V-8	EST	1995-1998	F350583 - L304599	18-5281		18-5405	18-5354	18-5443	18-5494-2 Ⓣ	18-8836-1
										18-5498-1 Ⓣ	
350 MAG MPI SKI (GEN +)	350/V-8	☛	1999-2001	L304600 - M2999999			18-5431	18-5395	18-5438		
350 MAG MPI SKI	350/V-8	EST	2002-2007	M300000 - A089999				18-5244			18-8828-1
350 MAG SKI	350/V-8	Ⓣ, ♣	1991-1997	D505450 - K999999			18-5431	18-5395	392-805570A 2		
350MAG BRAVO	V8		1995-1998	F415189 - L325952	18-5281		18-5405	18-5354	18-5443	18-5494-2 Ⓣ	18-8836-1
MPI &(Gen+)										18-5498-1 Ⓣ	
350MAG EFI SKI	V8		1996-1997	F820707 - K999999	18-5281		18-5405	18-5354	18-5443	18-5494-2 Ⓣ	18-8832-1
&(Gen+)										18-5498-1 Ⓣ	
5.0L Alpha &	V8		1998-2001	L015751 & up	18-5273		18-5431	18-5395	18-5438	18-5494-2 Ⓣ	18-8821-1
Bravo(Gen+)										18-5498-1 Ⓣ	
5.0L EFI (Gen +)	V8		1999-2001	L331631 & up	18-5273		18-5431	18-5395	18-5438	18-5494-2 Ⓣ	18-8834-1
										18-5498-1 Ⓣ	
5.0L MCM/MIE MPI,	V8		2001 & up	M300000 & UP	18-5247		18-5245	18-5244	18-5465	18-5351	18-8828-1
198, 898, 5.0L GM	V8		1983-1984	6218462 - 6899057	18-5273		18-5431	18-5395	18-5438	18-5494-2	18-8804-1
(305cid)										18-5498-1	
200, 5.0L GM	V8		1985-1995	6218462 - F600999	18-5273		18-5431	18-5395	18-5438	18-5494-2	18-8804-1
(305cid)										18-5498-1	18-8834-1
200, 5.0L GM	V8		1987-1995	B525982 - F600999	18-5273		18-5431	18-5395	18-5438	18-5494-2	
(305cid)										18-5498-1	
5.7L	350/V-8	Ⓣ, ♣	1988-2010	6218462 & UP			18-5431	18-5395			18-8828-1
5.7L EFI	350/V-8	EST	1995-1997	F225560 - K999999				18-5354			18-8828-1
5.7L EFI (GEN +)	350/V-8	EST	1998	L010035 - L325976				18-5354	18-5442		
5.7L EFI (GEN +)	350/V-8	EST	1998	L326000 - L331598				18-5354	18-5442		
5.7L EFI (GEN +)	350/V-8	EST	1998	L336000 - L339999				18-5354	18-5442		
5.7L EFI (GEN +)	350/V-8	☛	1999	L325977 - L325999			18-5431	18-5395	18-5438		
5.7L EFI (GEN +)	350/V-8	☛	1999	L331599 - L331991			18-5431	18-5395	18-5438		
5.7L EFI (GEN +)	350/V-8	☛	1999	L335716 - L335999			18-5431	18-5395	18-5438		
5.7L EFI (GEN +)	350/V-8	☛	1999-2001	L340000 - M299999			18-5431	18-5395	18-5438		
5.7L EFI MIE (GEN +)	350/V-8	☛	1997	K040300 - K999999					18-5442		
5.7L MIE	350/V-8	Ⓣ, ♣	1988-2010	B788152 & UP			18-5431	18-5395			
5.7L MPI HORIZON MIE	350/V-8	EST	2008-2010	A090000 & UP				18-5244			18-8821-1
5.7L MPI MIE	350/V-8	EST	2008-2010	A090000 & UP				18-5244			
5.7L MPI SKI	350/V-8	EST	2008-2010	A090000 & UP				18-5244	18-5433		18-8821-1
5.7L SKI	350/V-8	Ⓣ	1985-1995	A338553 - F775199	18-5251 ★	18-5314	18-5404-1	18-5376	18-5433	18-5494-2 Ⓣ	18-8802-1
					18-5271 ☞					18-5498-1 Ⓣ	
5.7L SKI	350/V-8	Ⓣ	1985-1996	A338553 - F775199	18-5262 ★	18-5303	18-5403	18-5352	18-5433	18-5494-2 Ⓣ	18-8802-1
					18-5275 ☞					18-5498-1 Ⓣ	
5.7L SKI	350/V-8	Ⓣ, ♣	1987-2010	B514627 & UP			18-5431	18-5395			
5.7LX	350/V-8	♣	1995-1997	F601000 - K999999			18-5431	18-5395	18-5438		
5.7LX BRAVO EFI (GEN +)	350/V-8	EST	1996-1997	F800300 - K999999				18-5354			
5.7LX EFI	350/V-8	EST	1996-1997	F752400 - K999999	18-5281		18-5405	18-5354	18-5442	18-5494-2 Ⓣ	18-8836-1
										18-5498-1 Ⓣ	

Ⓣ Mallory Ignition
 Ⓣ Prestolite
 Ⓣ Autolite
 Ⓣ Mercury Ignition
 Ⓣ Holley
 Ⓣ Thunderbolt IV

☛ With screw down cap
 Ⓣ Delco
 Ⓣ Electronic dist. (std rotation) excluding Thunderbolt ignition
 Ⓣ Delco EST
 ♣ Delco digital system
 ★ With out dist cap

☞ With dist cap
 ☛ Mercury HEI
 EST Delco HEI
 ♣ Thunderbolt V
 ♥ Prestolite with clip down dist cap
 ☞ Contact controlled dist. (Std. Rotation) excl. Thunderbolt ign.

MODEL	Cyl.	Ignition Type	Year	Serial #	Tune-Up Kit	Contact Set	Rotor	Dist. Cap	Coil	Distributor	Spark Plug Wires
5.7L MIE & SKI	V8		1998 & up	L002003 & up	18-5273 ★		18-5431	18-5395	18-5438		18-8830-1
5.7L EFI & (Gen+)	V8		1995-1998	F225560-L339999	18-5281 ☞		18-5405	18-5354	18-5442	18-5494-2 Ⓣ	18-8836-1
										18-5498-1 Ⓣ	
5.7L EFI & (Gen+)	V8		1999-2001	L325977 & UP	18-5273		18-5431	18-5395	18-5438	18-5494-2 Ⓣ	18-8834-1
										18-5498-1 Ⓣ	
5.7L SKI	V8		1987-1997	B514627 - K999999	18-5273		18-5431	18-5395	18-5438	18-5494-2 Ⓣ	18-8821-1
										18-5498-1 Ⓣ	
5.7L SKI	V8		1987-1995	B514627 - F775199	18-5273		18-5431	18-5395	18-5433	18-5494-2 Ⓣ	18-8821-1
										18-5498-1 Ⓣ	
5.7L SKI	V8		1998-2001	L002005 & up	18-5273		18-5431	18-5395	18-5438	18-5494-2 Ⓣ	18-8821-1
										18-5498-1 Ⓣ	
260, 350MAG	V8		1987-1995	B525982 - F600999	18-5273		18-5431	18-5395	18-5438	18-5494-2	18-8804-1
5.7L SKI/ ALPHA/ BRAVO(350cid)										18-5498-1	
260, 350MAG, 5.7L ALPHA/ BRAVO(350cid)	V8		1987-1995	B525982 - F600999	18-5273		18-5431	18-5395	18-5438	18-5494-2	18-8821-1
										18-5498-1	
350MAG, 5.7L/ LX ALPHA &	V8		1994-2001	F353525 & UP	18-5273		18-5431	18-5395	18-5438	18-5494-2	18-8821-1
										18-5498-1	
BLACK SCORPION SKI (GEN+)	350/V-8	☞	1996-2003	F800000 - M391599				18-5354	18-5443		18-8832-1
BLACK SCORPION SKI (GEN+)	350/V-8	☞	2003-2007	M391600 - W698432				18-5395			
SCORPION 350	350/V-8	☞	2008-2010	W698433 & UP				18-5395			
BLACK SCORPION SKI(Gen+) (350cid)	V8		1996	F800000 - K040000	18-5281		18-5405	18-5354	18-5443	18-5494-2	18-8832-1
										18-5498-1	
BLACK SCORPION SKI(Gen+) (350cid)	V8		1997-1998	K040001 - L005600	18-5281		18-5405	18-5354	18-5443	18-5494-2	18-8824-1
										18-5498-1	
BLACK SCORPION SKI(Gen+) (350cid)	V8		1998-2002	L005601 - M391599	18-5281		18-5405	18-5354	18-5443	18-5494-2	18-8822-1
										18-5498-1	
233 MCM & MIE (FORD)	351/V-8	Ⓣ	1975-1977	4173000 - 4902304	18-5260 ★ 18-5275 ☞	18-5303	18-5409	18-5352	18-5433	18-5489-2 Ⓣ 18-5312-1 Ⓢ	18-8803-2
233 MCM & MIE (FORD)	351/V-8	▼	1975-1977	4173000 - 4902304	18-5258 ★ 18-5277 ☞	18-5303	18-5407	18-5369	18-5433	18-5489-2 Ⓣ 18-5312-1 Ⓢ	18-8803-2
233 MCM & MIE (FORD)	351/V-8	Ⓣ	1975-1977	4173000 - 4902304	18-5254	18-5317	18-5420	18-5389	18-5433	18-5489-2 Ⓣ 18-5312-1 Ⓢ	18-8803-2
255 MCM & MIE	351/V-8		1973-1974	3385721 - 4166999	18-5254	18-5317	18-5420	18-5389	18-5433	18-5489-2 18-5312-1	18-8803-2
255 MCM & MIE	351/V-8		1973-1974	3385721 - 4166999	18-5251 18-5271	18-5314	18-5404-1	18-5376	18-5433	18-5489-2 18-5312-1	18-8803-2
255 MIE & MCM (FORD)	351/V-8	Ⓣ	1973-1980	3258728 - 5907057		18-5314	18-5404-1		18-5433		
255 MIE & MCM (FORD)	351/V-8	Ⓣ	1973-1980	3258728 - 5907057			18-5420	18-5389	18-5433		
255, 260MCM & MIE(350cid)	V8		1975-1982	3258728 - 6218461	18-5251 18-5271	18-5314	18-5404-1	18-5376	18-5433	18-5494-2 Ⓣ 18-5498-1 Ⓣ 18-5313-1 Ⓢ	18-8803-2
255MCM & MIE (350cid)	V8		1975-1980	4498701 - 5907057	18-5254	18-5317	18-5420	18-5389	18-5433	18-5494-2 Ⓣ 18-5498-1 Ⓣ 18-5313-1 Ⓢ	18-8803-2
260,350MAG,	V8		1982-1994	6218462 - F600999	18-5273		18-5431	18-5395	18-5438	18-5494-2 Ⓣ 18-5498-1 Ⓣ 18-5313-1 Ⓢ	18-8804-1
300, 320EFI	350/V-8		1985-1989	A543604 - C622418	18-5273		18-5431	18-5395	18-5438	18-5494-2 Ⓣ 18-5498-1 Ⓣ	18-8804-1
377 MAG	377/V-8	☞	2008-2010	A300000 & UP				18-5244			
377 SCORPION MCM	377/V-8	☞	1999-2005	L416146 - M907201	18-5281		18-5405	18-5354	18-5443	18-5494-2 Ⓣ	
										18-5498-1 Ⓣ	

- Ⓣ Mallory Ignition
- Ⓣ Prestolite
- Ⓣ Autolite
- Ⓣ Mercury Ignition
- Ⓣ Holley
- Ⓣ Thunderbolt IV

- ☞ With screw down cap
- Ⓣ Delco
- Ⓣ Electronic dist. (std rotation) excluding Thunderbolt ignition
- Ⓣ Delco EST
- Ⓢ Delco digital system
- ★ With out dist cap

- ☞ With dist cap
- ☞ Mercury HEI
- ☞ Delco HEI
- Ⓢ Thunderbolt V
- ▼ Prestolite with clip down dist cap
- Ⓢ Contact controlled dist. (Std. Rotation) excl. Thunderbolt ign.

MODEL	Cyl.	Ignition Type	Year	Serial #	Tune-Up Kit	Contact Set	Rotor	Dist. Cap	Coil	Distributor	Spark Plug Wires
377 SCORPION SKI	377/V-8		1997-1998	K000656 - L00314	18-5281		18-5405	18-5354	18-5443	18-5494-2 ⓐ	
										18-5498-1 ⓑ	
MX 6.2L MPI	377/V-8	⬅	2000-2001	L680003 - M299999	18-5273		18-5431	18-5395	18-5438	18-5494-2 ⓐ	18-8834-1
										18-5498-1 ⓑ	
MX 6.2L MPI (377CID)	377/V-8	EST	2002-2007	M300000 - A299999	18-5247		18-5245	18-5244			18-8828-1
MX 6.2L MPI	377/V-8		2001-2004	M300000 & UP	18-5247		18-5245	18-5244	18-5465	18-5351	18-8828-1
MX 6.2L MPI HORIZON	377/V-8	EST	2002-2007	M300000 - A299999	18-5247		18-5245	18-5244	18-5465	18-5351	18-8828-1
MX 6.2L MPI HORIZON MIE	377/V-8	EST	2002-2010	M300000 & UP	18-5247		18-5245	18-5244	18-5465	18-5351	18-8828-1
MX 6.2L MPI MIE	377/V-8	⬅	2000-2001	L670000 - M299999			18-5431	18-5395	18-5438		
MX 6.2L MPI MIE	377/V-8	EST	2002-2010	M300000 - & UP				18-5244			18-8828-1
MX 6.2L MPI SKI	377/V-8	EST	2002-2007	M317000 - A089999	18-5247		18-5245	18-5244			18-8828-1
MX 6.2L BLACK SCORPION SKI	377/V-8	EST	2001-2003	F800000 - M391599				18-5354			N/A
MX 6.2L BLACK SCORPION SKI	377/V-8	⬅	2003-2007	M391600 - W698432				18-5395			
SCORPION 377	377/V-8	⬅	2008-2010	W698433 & UP				18-5395			
325 MCM & MIE	427/V-8	♣	1969-1974	2278747 & UP	18-5282		18-5420	18-5389		18-5494-2 ⓐ	18-8803-2
										18-5498-1 ⓑ	
330 MCM & MIE	454/V-8	ⓐ	1977-1981	4623115-6083144	18-5251 ★	18-5314	18-5404-1	18-5376	18-5433	18-5494-2 ⓐ	18-8803-2
					18-5271 ☞					18-5498-1 ⓑ	
										18-5313-1 ⓐ	
330 MCM & MIE	454/V-8	♣	1977-1981	4623115-6083144	18-5282		18-5420	18-5389		18-5494-2 ⓐ	18-8803-2
										18-5498-1 ⓑ	
										18-5313-1 ⓐ	
330	454/V-8	ⓐ	1982-1987	6083145 - B816540			18-5431	18-5395	18-5438		
330, 340, 7.4L	454/V-8		1981-1992	5889914 - D715493	18-5273		18-5431	18-5395	18-5438	18-5494-2 ⓐ	18-8804-1
MCM & MIE(454cid)										18-5498-1 ⓑ	
340 MIE	454/V-8	ⓐ	1981-1987	5889914 - B788365			18-5431	18-5395	18-5438		
350 MIE	454/V-8	♣	1974-1976	3780450 - 4623109	18-5282		18-5420	18-5389		18-5494-2 ⓐ	18-8803-2
										18-5498-1 ⓑ	
370 TRS	454/V-8	ⓐ	1978-1985	4179554 - 6721527	18-5251 ★	18-5314	18-5404-1	18-5376	18-5433	18-5494-2 ⓐ	18-8803-2
					18-5271 ☞					18-5498-1 ⓑ	
										18-5313-1 ⓐ	
370 TRS	454/V-8	ⓐ	1978-1985	4883520 - 6721527	18-5254	18-5317	18-5420	18-5389	18-5433	18-5494-2 ⓐ	18-8803-2
										18-5498-1 ⓑ	
										18-5313-1 ⓐ	
370 TRS	454/V-8	ⓐ	1985-1987	6721528 - B714586	18-5273		18-5431	18-5395	18-5433	18-5494-2 ⓐ	18-8804-1
										18-5498-1 ⓑ	
400 TRS	454/V-8	ⓐ	1980-1986	5668232 - B457644		18-5314	18-5404-1		18-5433		
400 TRS	454/V-8	ⓐ	1980-1986	5668232 - B457644		18-5317		18-5389	18-5433		
420	454/V-8	ⓐ	1987-1989	A398941 - B622418	18-5273		18-5431	18-5395	18-5438	18-5494-2 ⓐ	18-8837-1
										18-5498-1 ⓑ	
425	454/V-8	ⓐ	1990-1993	B622419 - D937011			18-5431	18-5395	18-5438		18-1837-1
440 TRS	454/V-8	ⓐ	1983-1986	6181070 - B485220		18-5314	18-5404-1		18-5433		
450	454/V-8	ⓐ	1995-1996	F347100 - F347277	18-5273		18-5431	18-5395	18-5438	18-5494-2 ⓐ	
										18-5498-1 ⓑ	
454 MAG ALPHA	454/V-8	ⓐ	1986-1997	A631894 - B785148	18-5273		18-5431	18-5395	18-5438	18-5494-2 ⓐ	18-8804-1
										18-5498-1 ⓑ	
454 MAG BRAVO	454/V-8	ⓐ, ♣	1988-1997	B721206 - K999999			18-5431	18-5395	18-5438		
454 MAG EFI	454/V-8	EST	1994-1996	F115700 - F802349				18-5354	18-5443		18-8832-1
454 MAG MPI	454/V-8	EST	1996-1998	F802350 - L085009				18-5354	18-5443		18-8832-1
454 MAG MPI	454/V-8	EST	1998-2001	L085010 - M024999				18-5354	18-5443		18-8832-1
454 MAG MPI HORIZON MIE	454/V-8	EST	1998-2001	L002200 - L674000	18-5281		18-5405	18-5354	18-5443	18-5494-2 ⓐ	
										18-5498-1 ⓑ	
454-EFI,MAG MPI	454/V-8		1994-2001	F115700 & UP	18-5281		18-5405	18-5354	18-5443	18-5494-2 ⓐ	18-8832-1
HORIZON MIE										18-5498-1 ⓑ	

- ⓐ Mallory Ignition
- ⓑ Prestolite
- ⓐ Autolite
- ⓐ Mercury Ignition
- ⓐ Holley
- ⓐ Thunderbolt IV

- ⓐ With screw down cap
- ⓐ Delco
- ⓐ Electronic dist. (std rotation) excluding Thunderbolt ignition
- ⓐ Delco EST
- ♣ Delco digital system
- ★ With out dist cap

- ☞ With dist cap
- ⬅ Mercury HEI
- EST Delco HEI
- ♣ Thunderbolt V
- ♥ Prestolite with clip down dist cap
- ♣ Contact controlled dist. (Std. Rotation) excl. Thunderbolt ign.

MODEL	Cyl.	Ignition Type	Year	Serial #	Tune-Up Kit	Contact Set	Rotor	Dist. Cap	Coil	Distributor	Spark Plug Wires
454 MAG MPI	454/V-8		1999-2001	L086001 - L674000	18-5281		18-5405	18-5354	18-5443	18-5494-2 ⑥	18-8832-1
HORIZON MIE										18-5498-1 ⑥	
454 MAG MPI SKI	454/V-8	EST	1995-1997	F215800 - K999999				18-5354	18-5443		18-8832-1
525 SC	454/V-8	⑥, ♣	1991-1999	D456000 - L415623			18-5431	18-5395			
7.4L BRAVO	454/V-8	⑥, ♣	1988-1997	B771113 - K999999			18-5431	18-5395			
7.4L MIE	454/V-8	⑥, ♣	1988-1997	B788366 - K999999			18-5431	18-5395			
7.4L MPI (L29)	454/V-8	EST	1998-2001	L010003 - M024330				18-5354	18-5443		18-8832-1
7.4L MPI MIE	454/V-8	EST	1995-1997	F563052 - K999999				18-5354	18-5443		18-8832-1
7.4L MPI MIE (L29)	454/V-8	EST	1998-2001	L002006 - L674613				18-5354	18-5443		18-8832-1
7.4L TBI MIE	454/V-8	EST	1996-1997	F874815 - K999999				18-5354			N/A
7.4LX BRAVO EFI	454/V-8	EST	1996-1997	F820000 - K999999				18-5354	18-5443		18-8832-1
7.4LX BRAVO MPI	454/V-8	EST	1996-1997	F602010 - K999999				18-5354	18-5443		18-8832-1
390	482/V-8	♣	1969-197070	2781129 - 2825059	18-5282		18-5420	18-5389			18-8803-2
460 TRS	482/V-8	⑥	1983-198686	6180970 - 6181046	18-5251	18-5314	18-5404-1	18-5376	18-5433	18-5494-2 ⑥	18-8803-2
										18-5498-1 ⑥	
										18-5313-1 ⚡	
460 TRS	482/V-8	⑥	1983-1986	6180970 - 6181046	18-5254	18-5317	18-5420	18-5389	18-5433	18-5494-2 ⑥	18-8803-2
										18-5498-1 ⑥	
										18-5313-1 ⚡	
465	V8		1992-1994	D763732 - F213244	18-5273		18-5431	18-5395	18-5438		18-8837-1
496 / 8.1L	V8		2000 & Up	M025000 & UP			N/A				18-8838-1
500	502/V-8	⑥, ♣	1994-1999	F213293 - L601036	18-5273		18-5431	18-5395	18-5438		18-8837-1
500 EFI	502/V-8	EST	1998-2005	L001477 - M907127				18-5354	18-5443		
502 MAG	502/V-8	⑥	1990-1993	C878221 - F114528	18-5273		18-5431	18-5395	18-5438		18-8804-1
502 MAG EFI	502/V-8	EST	1993-1996	D840650 - F802599				18-5354	18-5443		18-8832-1
502 MAG MPI	502/V-8	EST	1996-1998	F802600 - L085000				18-5354	18-5443		18-8832-1
500(Gen+)	502/V-8		1999	L414639 - L601036	18-5273		18-5431	18-5395	18-5438		18-8837-1
500GM EFI	502/V-8		1998-2000	0L001477 & up	18-5281		18-5405	18-5354	18-5443		
502 MAG MPI	502/V-8		1993-1998	D840650 - L085000	18-5281		18-5405	18-5354	18-5443		18-8832-1
502GM MAG	502/V-8		1998-2001	L085001 & up	18-5281		18-5405	18-5354	18-5443		18-8832-1
8.2L GM MPI MIE	502/V-8		1996-2001	F819620 & up	18-5281		18-5405	18-5354	18-5443		18-8832-1
8.2L GM MPI MIE	502/V-8		1990-1996	C878221 - F819619	18-5273		18-5431	18-5395	18-5438		18-8804-1
525 SC	502/V-8		1991-1995	0D456000-0F877734	18-5273		18-5431	18-5395	18-5438		18-8804-1
525 SC	502/V-8		1996-1999	0K000012 & up	18-5273		18-5431	18-5395	18-5438		18-8837-1
575 SCi	502/V-8	EST	2000-2005	L306696 - M950526				18-5354	18-5443		
575 SCi	502/V-8		2000-2005	L306696 & UP	18-5281		18-5405	18-5354	18-5443		
600 SC	502/V-8	⑥, ♣	1991-2000	D456489 - L301186			18-5431	18-5395	18-5438		
600 SC	502/V-8		1991-1993	D456489 - D763875	18-5273		18-5431	18-5395	18-5438		18-8837-1
600 SC	502/V-8		1993-2001	D763876 & UP	18-5273		18-5431	18-5395	18-5438		18-8837-1
8.2L MIE	502/V-8	⑥, ♣	1990-1996	C878221 - F819619			13524T 1	18-5395	18-5438		
8.2L MPI MIE	502/V-8	EST	1996-1998	F819620 - L086012				18-5354	18-5443		
8.2L MPI MIE	502/V-8	EST	1998-2001	L086013 - L674200				18-5354	18-5443		
500 BULLDOG	540/V-8	⑥, ♣	1990-2001	C577003 - M050281	18-5273		18-5431	18-5395	18-5438		18-8837-1
575	540/V-8	⑥	1986-1992	A677429 - D763716			18-5431	18-5395	18-5438		
800 SC	572/V-8	⑥, ♣	1993-1998	D763836 & UP	18-5273		18-5431	18-5395	18-5438		18-8837-1

- ① Mallory Ignition
- ② Prestolite
- ③ Autolite
- ④ Mercury Ignition
- ⑤ Holley
- ⑥ Thunderbolt IV
- ⑦ With screw down cap
- ⑧ Delco
- ⑨ Electronic dist. (std rotation) excluding Thunderbolt ignition
- ⑩ Delco EST
- ♣ Delco digital system
- ★ With out dist cap
- ⊞ With dist cap
- ♣ Mercury HEI
- EST Delco HEI
- ♣ Thunderbolt V
- ♥ Prestolite with clip down dist cap
- ⚡ Contact controlled dist. (Std. Rotation) excl. Thunderbolt ign.

PREMIUM MARINE IGNITION WIRES

Sierra's MAGFORCE Ignition Wires are "Electronics Friendly" protecting all of your electronic devices and electronic engine controls from RFI and EMI while delivering the maximum amount of voltage. Exact fit design ensures easy installation and years of trouble - free service.

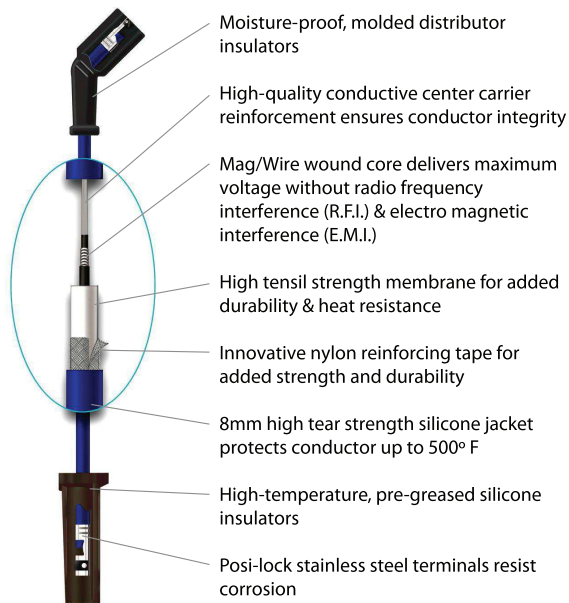

MERCURUISER MARINE IGNITION WIRES APPLICATION

Model	Cyl.	Distributor	Year Start	Year Stop	Serial # Start	Serial # End	Plug Wire Set
110	4	Delco	1963	1966	1537370	2044033	18-8800-1
120	4	Delco	1964	1986	1666601	0B531853	18-8800-1
2.5L	4	Delco	1987	1989	0B531854	0C853255	18-8800-1
140	4	Delco	1968	1986	2508261	0B450800	18-8800-1
3.0L	4	Delco	1987	1989	0B450801	0C856558	18-8800-1
3.0L, LX	4	Prestolite	1990	1991	0C856559	0D504541	18-8800-1
3.0L, LX	4	Delco Digital	1990	1991	0C856559	0D504541	18-8811-1
3.0L	4	Delco EST	1991	& Up	0D504542	& Up	18-8833-1
3.0LX	4	Delco EST	1991	1997	0D504542	0K999999	18-8833-1
3.0L MPI	4	Delco EST	2012	& Up	1A072812	& Up	18-8833-1
165	4	Delco	1987	1987	0B434940	0B774251	18-8808-2
170	4	Delco	1985	1986	6916779	0B434940	18-8808-2
180	4	Prestolite	1987	1987	0B436391	0B775248	18-8800-1
190	4	Delco	1985	1986	6916779	0B436390	18-8808-2
3.7L	4	Delco	1988	1989	0B774252	& Up	18-8808-2
3.7LX	4	Delco	1988	1989	0B775249	& Up	18-8808-2
3.7LX	4	Prestolite	1988	1989	0B775249	& Up	18-8800-1
470	4	Delco	1976	1984	4208370	6916778	18-8808-2
485	4	Delco	1980	1982	5685394	6218036	18-8808-2
488	4	Delco	1981	1984	6170297	6916778	18-8808-2
140	L6	Delco	1963	1963	1538930	1725960	18-8809-1
150	L6	Delco	1964	1966	1666495	2048046	18-8809-1
160	L6	Delco	1967	1969	2048022	2770031	18-8809-1
165	L6	Delco	1970	1981	2770032	5813433	18-8809-1
200	L6	Delco	1969	1969	2453769	2712072	18-8809-1
185	6	Prestolite	1983	1984	6330183	6919655	18-8801-1
175	6	Thunderbolt IV	1987	1987	0B527955	0B773242	18-8810-1

APPLICATION CONTINUED ON NEXT PAGE

MERCUISER MARINE IGNITION WIRES APPLICATION

Model	Cyl.	Distributor	Year Start	Year Stop	Serial # Start	Serial # End	Plug Wire Set
185	6	Thunderbolt IV	1985	1987	6919656	0B527954	18-8810-1
205	6	Thunderbolt IV	1985	1987	0A331445	0B775129	18-8810-1
262 Mag	6	Delco EST	1996	1997	0F803800	0K999999	18-8835-1
4.3L	6	Thunderbolt IV	1988	1996	0B773243	0F802999	18-8810-1
4.3L Alpha	6	Thunderbolt V	1998	& Up	0L010044	& Up	18-8810-1
4.3L Bravo	6	Thunderbolt V	1998	& Up	0L010044	& Up	18-8810-1
4.3L EFI	6	Delco EST	1998	1998	0L012009	0L359999	18-8835-1
4.3L EFI	6	Thunderbolt V	1999	2004	0L360000	& Up	18-8810-1
4.3L MPI	6	Delco HVS	2001	& Up	0M300000	& Up	18-8829-1
4.3LH Alpha	6	Thunderbolt V	1998	2004	0L010044	& Up	18-8810-1
4.3LH Bravo	6	Thunderbolt V	1998	2004	0L010044	& Up	18-8810-1
4.3LX, LXH	6	Thunderbolt IV	1988	1997	0B775130	0K999999	18-8810-1
215 MCM & MIE (Ford)	8	Autolite/Mallory	1970	1972	2781153	3563181	18-8803-2
225 MCM & MIE (Ford)	8	Autolite/Mallory/Mercury	1973	1974	3385721	4166999	18-8803-2
888 (Ford)	8	Autolite/Mallory	1971	1977	3108723	4887829	18-8803-2
190 (GM)	8	Delco	1963	1964	1564539	1730903	18-8803-2
198 MIE	8	Mallory	1977	1977	4776402	4931099	18-8803-2
200	8	Thunderbolt IV	1985	1987	6899058	8774444	18-8821-1
228	8	Mallory	1977	1982	4765100	6218461	18-8803-2
228	8	Thunderbolt IV	1983	1984	6218462	6899268	18-8821-1
228 MIE	8	Mallory	1977	1980	4765100	5907057	18-8803-2
230	8	Thunderbolt IV	1985	1987	6899269	0B773739	18-8821-1
230 MIE (LH)	8	Thunderbolt IV	1981	1987	5907058	0B788151	18-8821-1
230 MIE (RH)	8	Thunderbolt IV	1981	1987	5907058	0B788151	18-8821-1
5.0L	8	Thunderbolt IV	1988	1995	0B774445	0F600999	18-8821-1
5.0L Alpha	8	Thunderbolt V	1998	& Up	0L015751	& Up	18-8821-1
5.0L Bravo	8	Thunderbolt V	1998	& Up	0L015751	& Up	18-8821-1
5.0L EFI	8	Delco EST	1998	1998	0L012052	0L339999	18-8822-1
5.0L MIE (LH)	8	Thunderbolt IV	1988	1988	0B788152	0C396832	18-8821-1
5.0L MIE (RH)	8	Thunderbolt IV	1988	1988	0B788152	0C396832	18-8821-1
5.0L MPI Alpha	8	Delco HVS	2001	& Up	0M300000	& Up	18-8828-1
5.0LX	8	Thunderbolt IV	1988	1995	0B773740	0F600999	18-8821-1
898	8	Mallory	1977	1982	4762210	6218461	18-8803-2
898	8	Thunderbolt IV	1983	1984	6218462	6899057	18-8821-1
225 (GM)	8	Delco	1963	1969	1539620	2694014	18-8803-2
225 MIE (GM)	8	Thunderbolt	1968	1968	2278647	2694014	18-8803-2
250 MCM & MIE	8	Thunderbolt	1968	1969	2314301	2639854	18-8803-2
250	8	Mallory	1977	1977	4768000	4908849	18-8803-2
255 MCM & MIE	8	Mallory	1975	1976	3258728	4501254	18-8803-2
255 MCM & MIE	8	Mercury	1976	1976	4498701	4767999	18-8803-2
255 MIE	8	Mercury	1977	1980	4768000	5907057	18-8803-2
260	8	Mallory	1978	1982	4908850	6218461	18-8803-2
260	8	Thunderbolt IV	1982	1987	6218462	0B773304	18-8821-1
260 MIE (LH)	8	Thunderbolt IV	1981	1986	5907058	0B788151	18-8821-1
260 MIE (RH)	8	Thunderbolt IV	1981	1986	5907058	0B788151	18-8821-1
270 MCM & MIE	8	Thunderbolt	1969	1972	2851074	3385720	18-8803-2
280 TRS	8	Mercury/Mallory	1975	1975	4176250	4499390	18-8803-2
300	8	Thunderbolt IV	1985	1986	6668677	0B430367	18-8821-1
320 EFI	8	Thunderbolt IV	1987	1989	0A543604	0C622418	18-8821-1
350 Mag Alpha	8	Thunderbolt IV	1986	1994	0A635178	0F353690	18-8821-1
350 Mag Alpha	8	Thunderbolt V	1995	1997	0F353691	0K999999	18-8821-1
350 Mag Alpha EFI	8	Delco EST	1996	1997	0F800300	0K999999	18-8822-1

APPLICATION CONTINUED ON NEXT PAGE

MERCURUISER MARINE IGNITION WIRES APPLICATION							
Model	Cyl.	Distributor	Year Start	Year Stop	Serial # Start	Serial # End	Plug Wire Set
350 Mag Bravo MPI	8	Delco EST	1995	1996	0F415189	0K999999	18-8822-1
350 Mag EFI Ski	8	Delco EST	1994	1997	0F215561	0K999999	18-8822-1
350 Mag MPI	8	Delco EST	1998	1998	0L010019	0L325952	18-8822-1
350 Mag MPI Alpha	8	Delco HVS	2001	& Up	0M300000	& Up	18-8828-1
350 Mag MPI Bravo	8	Delco HVS	2001	& Up	0M300000	& Up	18-8828-1
350 Mag MPI Horizon	8	Delco HVS	2001	& Up	0M300000	& Up	18-8828-1
350 Mag MPI Horizon MIE	8	Delco HVS	2001	& Up	0M300000	& Up	18-8828-1
350 Mag MPI MIE	8	Delco HVS	2001	& Up	0M300000	& Up	18-8828-1
350 Mag MPI Ski	8	Thunderbolt IV	1991	1996	0D505450	0K40399	18-8821-1
350 Mag MPI Ski	8	Thunderbolt V	1991	1997	0D505450	0K999999	18-8821-1
5.7L Alpha	8	Thunderbolt IV	1988	1995	0B773305	0F600999	18-8821-1
5.7L Alpha	8	Thunderbolt V	1996	1997	0F601000	& Up	18-8821-1
5.7L Bravo	8	Thunderbolt IV	1988	1993	0B773305	0F353524	18-8821-1
5.7L Bravo	8	Thunderbolt V	1994	& Up	0F353525	& Up	18-8821-1
5.7L EFI	8	Delco EST	1995	1998	0F225560	0L339999	18-8822-1
5.7L EFI MIE	8	Delco EST	1997	1997	0K040300	0K999999	18-8822-1
5.7L MIE	8	Thunderbolt IV	1988	1995	0B788152	0F746099	18-8821-1
5.7L MIE	8	Thunderbolt V	1996	1997	0F622100	0K999999	18-8821-1
5.7L MIE	8	Thunderbolt V	1998	& Up	0L002003	& Up	18-8821-1
5.7L Ski	8	Mallory/Prestolite	1985	1995	0A338553	0F775199	18-8802-1
5.7L Ski	8	Thunderbolt IV	1987	1995	0B514627	0F775199	18-8821-1
5.7L Ski	8	Thunderbolt V	1996	1997	0F775200	0K999999	18-8821-1
5.7L Ski	8	Thunderbolt V	1998	& Up	0L002005	& Up	18-8821-1
5.7LX Alpha & Bravo	8	Thunderbolt V	1996	1997	0F601000	0K999999	18-8821-1
5.7LX Bravo & EFI	8	Delco EST	1996	1997	0F752400	0K999999	18-8822-1
233 MCM & MIE (Ford)	8	Mercury/Prestolite	1975	1977	4173000	4902304	18-8803-2
255 MCM & MIE (Ford)	8	Mercury/Mallory	1973	1980	3258728	5907057	18-8803-2
MX 6.2L MPI	8	Delco HVS	2001	& Up	0M300000	& Up	18-8828-1
MX 6.2L MPI Horizon	8	Delco HVS	2001	& Up	0M300000	& Up	18-8828-1
MX 6.2L MPI Horizon MIE	8	Delco HVS	2001	& Up	0M300000	& Up	18-8828-1
MX 6.2L MPI MIE	8	Delco HVS	2001	& Up	0M300000	& Up	18-8828-1
377 MAG MPI BRAVO	8	Delco HVS	ALL	ALL	1A300000	& Up	18-8828-1
325 MCM & MIE	8	Thunderbolt	1969	1974	2278747	& Up	18-8803-2
325 MCM & MIE	8	Mallory	1969	1972	2278747	& Up	18-8803-2
390	8	Mallory	1968	1970	ALL		18-8803-2
330	8	Mallory	1977	1981	4623115	6083144	18-8803-2
330	8	Thunderbolt	1977	1981	4623115	6083144	18-8803-2
330	8	Thunderbolt IV	1982	1987	6083145	0B816540	18-8821-1
340 MIE	8	Thunderbolt IV	1981	1987	5889914	0B788365	18-8821-1
350 MIE	8	Thunderbolt	1974	1976	3780450	4623109	18-8803-2
370 TRS	8	Mallory/Holley	1978	1985	4179554	6721527	18-8803-2
370 TRS	8	Thunderbolt IV	1985	1987	6721528	0B714586	18-8821-1
400 TRS	8	Mallory/Holley	1980	1986	5668232	0B457644	18-8803-2
440 TRS	8	Mallory/Holley	1983	1986	6181070	0B485220	18-8803-2
450	8	Thunderbolt IV	1995	1996	0F347100	0F347277	18-8821-1
454 Mag Alpha	8	Thunderbolt IV	1986	1988	0A631894	0B785148	18-8821-1
454 Mag Bravo	8	Thunderbolt IV	1988	1997	0B721206	0K999999	18-8821-1
454 Mag EFI	8	Delco EST	1994	1996	0F115700	0F802349	18-8822-1
454 Mag MPI	8	Delco EST	1996	2001	0F802350	M024999	18-8822-1
454 Mag MPI Horizon MIE	8	Delco EST	1999	2001	0L002200	0L674000	18-8822-1

APPLICATION CONTINUED ON NEXT PAGE

MERCURUISER MARINE IGNITION WIRES APPLICATION

Model	Cyl.	Distributor	Year Start	Year Stop	Serial # Start	Serial # End	Plug Wire Set
454 Mag MPI Ski	8	Delco EST	1995	1997	0F215800	0K999999	18-8822-1
7.4L Bravo I, II, III	8	Thunderbolt IV	1988	1997	0B771113	0K999999	18-8821-1
7.4L Bravo III	8	Thunderbolt V	1992	1997	603118	0K999999	18-8821-1
7.4L EFI MIE	8	Thunderbolt IV	1988	1996	0B788366	0F820141	18-8821-1
7.4L MIE	8	Thunderbolt IV	1988	1996	0B788366	0F820141	18-8821-1
7.4L MIE	8	Thunderbolt V	1992	1997	0D715494	0K999999	18-8821-1
7.4L MPI (L29)	8	Delco EST	1998	2001	0L010003	0M024330	18-8822-1
7.4L MPI MIE	8	Delco EST	1995	2001	0F563052	0M025999	18-8822-1
7.4LX Bravo EFI & MPI	8	Delco EST	1996	1997	0F602010	0K999999	18-8822-1
390	8	Thunderbolt	1969	1970	2781129	2825059	18-8803-2
460 TRS	8	Mallory/Holley	1983	1986	6180970	6181046	18-8803-2
460 Cyclone	8	ALL	1983	1985	ALL		18-8803-2
496 Mag & Mag HO	8	Delco (coil over plug)	2000	& Up	0M025000	& Up	18-8838-1
8.1 MIE & HO MIE	8	Delco (coil over plug)	2000	& Up	0M025000	& Up	18-8838-1
502 Mag Bravo	8	Thunderbolt IV	1990	1993	0G878221	0F114528	18-8821-1
502 Mag EFI	8	Delco EST	1993	1996	0B40650	0F802599	18-8822-1
502 Mag MPI	8	Delco EST	1996	2001	0F802600	0M024999	18-8822-1
525 SC	8	Thunderbolt IV	1991	1995	0D456000	0F877734	18-8821-1
8.2L MIE	8	Thunderbolt IV	1990	1996	0C878221	0F819619	18-8821-1
8.2L MPI MIE	8	Delco EST	1996	2001	0F819620	0L674200	18-8822-1



18-5225
SPARK PLUG WIRE KIT
 Replaces: Mercury 84-99215A26, 84-813706A26, 84-93475A26, 84-93212A1, 84-90816A26
 Kit includes 25 ft. roll of 7 MM hypalon ignition wire with a metallic core and a large assortment of three different end fittings.



18-5226
IGNITION WIRE
 Metallic Core
 100' Spool
 7mm Hypalon



BATTERY CABLES

Part No.	Size	Color	Gauge	Part No.	Size	Color	Gauge
BC88523	2'	red	4	BC88563	6'	red	2
BC88533	2'	black	4	BC88573	6'	black	2
BC88543	4'	red	2	BC88583	8'	red	1
BC88553	4'	black	2	BC88593	8'	black	1

Gauge cable with soldered lug terminals on each end to accept a 3/8" stud

PKG. OF 10

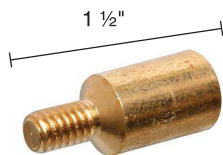

18-5224
18-5224-9^①
SPARK PLUG WIRE TERMINAL
 Replaces: 20121, 8M0084600

PKG. OF 10



18-5750
18-5750-9^①
UNIVERSAL SPARK PLUG BOOTS
 Supplied complete w/Terminal Connector



18-5752
UNIVERSAL SPARK PLUG BOOT
 8mm

Standard Rotation

CCW Rotation

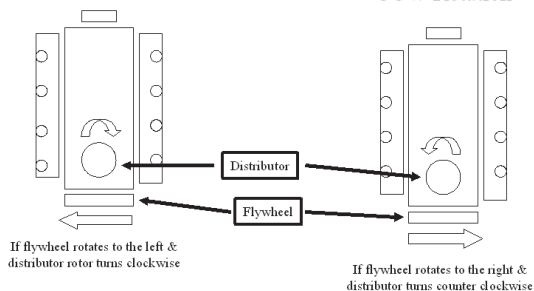

18-5603
STARTER
 Replaces: 50-808011A4
 Noseless:CCW Top mount rear entry starter for standard rotation GM & Ford engines. Can be used in place of 18-5908.



18-6275

STARTER

Replaces:

50-807904A1, 50-863007A1, 50-864340A2, 50-806964A4,
50-806964A3, 50-806964A2, 50-812604A2, 50-812428A3,
50-812428A3, 50-12177A2, 50-12121A2, 50-822330A2, 814472, 50-99418A2,
50-77328A3, 50-77328A1

- Permanent Magnet Gear Reduction Starter
- Inboard
- 2 Long Bolt Offset Pattern
- CW Rotation • SAE J1171
- Use w/ Late Model 3.0L Engines with 14" Flywheel

Fits: Volvo Penta, Mercruiser, Marine Power
Uses Solenoid **18-5811**



18-5923

STARTER

PMGR Replacement for **18-5903**;
302CID, 351CID Ford Engines



18-5911

STARTER

(Heavy-Duty) (No Core) (Clockwise) (9 tooth) For GM engines, bottom
mount straight across bolt pattern. Standard rotation.

Replaces: 50-76965A4, 50-99417A2, 50-99419A3, 50-17251A3

Replacement Solenoid: **18-5837**
SAEJ1171



18-5907

STARTER

(Heavy-Duty) (No Core) (Clockwise) (9 tooth) Top mount rear entry starter for opposite rotation GM & Ford engines.
Will also replace bottom mount standard rotation. Will not replace non-starter mounted solenoids.
Mercruiser built 4 cyl. 165/170/180/190/470/485/488

Replaces: 50-72550A2, 50-79604A3, 50-97499A2, 50-97499R4, 50-72550R2, 50-97499R3

Replacement Solenoid: **18-5837**
SAEJ1171



APPLICATION BEGINS ON PAGE 704

18-5913
STARTER
(Clockwise)

Delco permanent magnet gear reduction 2 bolt starter
12V - 11 Tooth - Offset Bolt Pattern
For: Late model GM - 14" Flywheel
Replaces: 50-812428A3, 50-812604A2,
50-822330A2, 50-864340A2
Includes 18-8402 (2) bolts
SAEJ1171
For: 4.3L (1996 & UP); 5.0 & 5.7L (1998 & UP)



18-5919
STARTER

Permanent magnet I/O starter, 11 Tooth
Replaces: 50-806963A4, 50-806965A2, 50-806965A4
Includes one 18-8402 bolt and one 18-8404 bolt
Fits: Chevy Engines with 12 3/4" flywheels
Straight across bolt pattern
SN-OF803000AN/OF803114AN 4.3LX/LXH Alpha/Bravo 262 CID
SN-355305AN/22560AN 5.7L Alpha (EFI)/5.7L Bravo (EFI)
SAEJ1171



18-5910
STARTER

(Heavy-Duty) (No Core) (Clockwise) (9 tooth) Small block V-6 & V-8 GM engine with 14 1/4" flywheel and bottom mount, offset bolt pattern. For standard rotation engines.
Replaces: 50-12177A2, 50-99418A2



18-5908
STARTER

(Heavy-Duty) (No Core) (Counter-Clockwise) (9 tooth)
Top mount rear entry starter for standard rotation GM & Ford engines. Front mount reverse rotation.
Replaces: 50-76965A3, 50-808011A1, 50-808011A05, 50-808011A4, 50-808011A3, 50-99419A3, 50-76967A4, 50-76967A1
50-65784A1, 50-47455, 50-17251A3, 50-17251A2
Replacement Solenoid: 18-5837
SEAJ1171





18-5903
STARTER
 (No Core) (Clockwise) Bottom mount, two bolt pattern for standard rotation Ford engines.
 Replaces: 50-69865A1, 50-12872, 50-56886
 Replacement Solenoid: **18-5801**
 *For PMGR style order **18-5923**

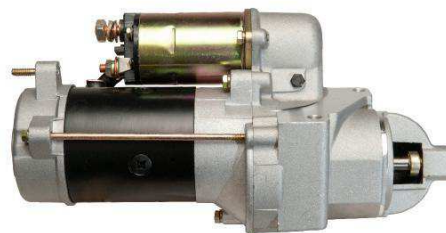

18-6870
STARTER
 Replaces: Mercury 50-805833, T
 Fits: D7.3L D-tronic 260 LD, 300 1999 year



18-6946
STARTER
 Replaces: 50-8m8021116
 Fits: High Performance 11 Tooth Starter for 6.2L & 8.9L Scorpion HO applications



18-6947
STARTER
 Replaces: Mercruiser 50-805991
 Fits: 7.3L (BRAVO & MIE) DIESEL NAV 444 V-8 1994-1996

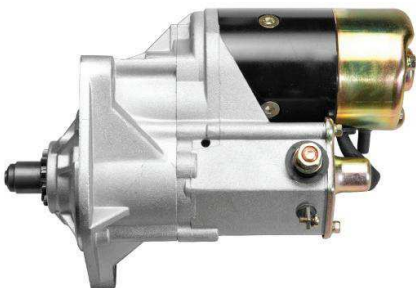

18-6949
STARTER
 Replaces: Mercruiser 50-831001562, 50-831001961
 Fits: WO4CTA (150 HP) HINO 234 I/L4, WO4CTI (210 HP) HINO 234 I/L4



18-6957
STARTER
 Replaces: Mercruiser 50-801333980, 50-854178, 50-855507



18-8412
STARTER STUD EXTENDER
 Extends the solenoid stud on PMGR starters for applications that require more accessory wire connections.
 Threads: Female M8x1.25, Male 3/8"x16 UNC



18-2434
FLYWHEEL BELL HOUSING
 Replaces: 814309A1
 For: GM V-8's Big & Small Blocks Inboard/Ski Models

STARTER BOLTS



Description	Mercruiser #	Part #
Starter Bolt 3/8 - 16 - 4 3/8 Long	10-8053432	18-8402
Starter Bolt 3/8 - 16 - 1 11/16 Long	10-8083434	18-8404-1



18-5717
STARTER
BRUSH SET
 Replaces: 33270

18-5804
SOLENOID
 Replaces: 13037
 Delco



18-5837
SOLENOID
 Replaces: 89-18080
 Delco



18-5838
SOLENOID
 Replaces: 33261, 33316,
 60687, 89902, 89-99253
 Delco



18-5840
SOLENOID
 Prestolite 15-79,
 SAW 4201, SAW4207, SAW4210



BRUSH SET/STARTER SWITCH APPLICATION

Years	Volt.	Starter No.	Brush Set	Starter Switch	Years	Volt.	Starter No.	Brush Set	Starter Switch
1977-82	12	1108755	18-5717	18-5838	1971-78	12	ALL	18-5717	18-5838
1977-82	12	1108756	18-5717	—	1969-78	12	MEO-7003	—	18-5840
1977-82	12	1109484,5,6	18-5717	18-5838					

① **18-5801D** Display Package

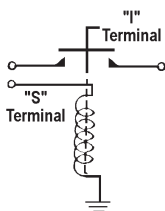

18-5801
SOLENOID
 Replaces: 89-76416A1

① **18-5802D** Display Package

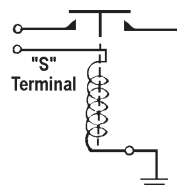

18-5802
SOLENOID
 Grounded base
 Replaces: 65057A1, 65057T1, 65057, 54981

① Items ending in "D" are Display Packaged - Regular number is Non-Display
APPLICATION BEGINS ON PAGE 704

① 18-5810D 



18-5810
SOLENOID



18-5811
STARTER SOLENOID
Replaces: 809463A1, 8094631, 809463, 8094621, 809462
For: PG 260 Series Starters, GM V6 & V8 (1983-Up)

① 18-5815D 





18-5815
SOLENOID
Replaces: 89-68258A4, 89-853654A1, 89-76545, 89-76545T, 89-65258, 89-61053, 89-15857

① 18-5816D 



18-5816
SOLENOID
Replaces: 89-96054, T, 89-91975
(Flat Bracket)

① 18-5817D 





18-5817
SOLENOID
Replaces: 89-96158, 89-96158T, 94318, 846070
(Curved Bracket)



18-5820
SOLENOID
Replaces: 89-818999A2, 89-825842A1, 89-850188T1

① 18-5836D 



18-5836
SOLENOID
Replaces: 25661, 256611, 25661T1



18-9802
TIMING LIGHT
Self-powered accurate up to 10,000 RPM's



18-6749
TRIM BRACKET
Metal Bracket
Replaces: 862548A1, 42419A1, 88893A4, 88553A1, 862548A1, 58397A3, 58397A2, 42419A1
For: MerCruiser Floor Mount Bracket



18-6750
TRIM BRACKET
Stainless Steel
Replaces: 862548A1, 42419A1
For: MerCruiser Floor Mount Bracket



18-6747
TILT/TRIM ASSEMBLY
Replaces: 865380A25, 865380A15, 865380A05, 865380A02, 14336A28, 14336A22, 14336A17, 14336A15, 14336A9, 14336A6, 88183A12, 88183A3
For late model sterndrive applications



18-6752
HYDRAULIC TRIM PUMP ASSEMBLY
Low Pressure - High Flow
Metal Bracket
Replaces: 14336A9, 88183A12, 96477A3, 88183A11, 88183A6, 14336A28, 14336A22, 14336A17, 14336A15, 14336A6
Fits: 1983 and Later without "quick connect"
Replacement Motor: 18-6772
20 amp fuse



18-6753
HYDRAULIC TRIM PUMP ASSEMBLY
Low Pressure - High Flow
Stainless Steel Bracket
Replaces: 14336A9, 88183A12
Fits: 1983 and Later without "quick connect"
Replacement Motor: 18-6772
20 amp fuse

① Items ending in "D" are Display Packaged - Regular number is Non-Display

APPLICATION BEGINS ON PAGE 704



18-6768
COMPLETE POWER TRIM PUMP ASSEMBLY
Steel Bracket
Replaces: 93247A7, 93247A4, 392-8261A1, 392-8263, 88475A4, 79271A4, 74436A9
 Replacement pump for Prestolite high pressure/low flow system. Primarily used 1982 and earlier. 20 amp fuse.



18-6799
COMPLETE POWER TRIM PUMP ASSEMBLY
Stainless Steel Bracket
Replaces: 93247A7, 93247A4, 392-8261A1, 392-8263, 88475A4, 79271A4, 74436A9
 Replacement pump for Prestolite high pressure/low flow system. Salt water series. Stainless steel bracket. Primarily used 1982 and earlier. 20 amp fuse.

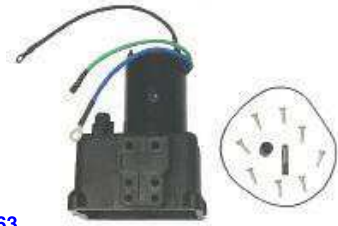

18-6763
TILT/TRIM MOTOR
Replaces: 92975A6, 79271A4, 67914A2, 92975A32, 93247A7
 To 1984. Fits most Mercruiser Sterndrives (Motor and Reservoir Only)
 For Repair Kit use: **18-6253**



18-6769-1
TILT/TRIM PUMP
Low Pressure - High Flow
Replaces: 14336A8, 88183A5 From 1984
Fits: Most Mercruiser Sterndrives



18-6772
TILT PUMP MOTOR
Replaces: 17649, 17649T, 891736T
 For late style Alpha I, Generation II, and Bravo drives; early style square motors.
 Mercruiser Sterndrive replacement for Oildyne units



18-6813
TRIM MOTOR
Low pressure/high flow
Replaces: 14336A6, A8, A9, A15, A20, 88183A5, A8, A12, 865380A13
 Same as **18-6769-1**, plus wiring
 Replacement Solenoid: **18-5817**



18-6746
TILT/TRIM ASSEMBLY
Replaces: 14336A20, 14336A25, 14336A31, 14336A8 865380A03, 865380A13, 88183A5



18-6771
TILT/TRIM RESERVOIR
Replaces: 18525, 18525A1, 17646



18-6778
TILT/TRIM RESERVOIR
Replaces: 883166A1, 883166A2
For: Tilt Motors with 4 Screw Attachments



18-6823
WIRING HARNESS
Replaces: Universal
 Converts 3-wire Tilt and Trim motors to 2-Wire design



18-6254
COMMUTATOR END PLATE
Replaces: 392-2940
For: Use with Prestolite Pumps (Mercury #'s 79271A4 and 88475A5)



18-6253
COMMUTATOR END PLATE
For: Use with **18-6763**



18-15501
CIRCUIT BREAKER
Replaces: 88-93582
60 AMP



18-6256
POWER TRIM SPRING SET
Replaces: 392-2529
For: Use with Prestolite Pumps (Mercury #'s 74436A9, 79271A4, 88475A5 and 93247A4)



18-6255
POWER TRIM BRUSH
Replaces: 392-8989
For: Use with Prestolite Pumps (Mercury #'s 93247A4)



18-5945
ALTERNATOR
 (3-Wire) (No Core) (68 AMP) • SAE J1171
Replaces Mando, Motorola and original equipment Delco. Uses same electrical connections and mounting method. Equipped with fan and serpentine drive pulley.



18-5946
ALTERNATOR
 (1-Wire) (No Core) (68 AMP)
 Single wire connection fits Mercruiser and many other applications. Equipped with fan and serpentine drive pulley.
 SAE J1171



18-5956
ALTERNATOR
(1-Wire) (No Core) (68 AMP)
Single wire connection fits Mercruiser and many other applications. Equipped with fan and drive pulley.
Replaces: 69729, 90794, 78403A2, 78403A1, 78477, 59755, 56045
SAE J1171



18-5957
ALTERNATOR
(3-Wire) (68 AMP)
Replaces Mando, Motorola and original equipment Delco. Uses same electrical connections and mounting method. Equipped with fan and drive pulley.
Replaces: 78477, 78403A2, 92497A3, 78403A1, 90794, 69729, 59755, 56045, 817119A4, 817119A1, 98555A1, 92497, 12449A1, 12449
SAE J1171



18-5960
ALTERNATOR
Serpentine Pulley • 65 Amp
Replaces: 807653T • SAE J1171



18-5965
ALTERNATOR
65 Amp
Replaces: 817119A1, 817119A4, 805884T, 98555A1, 92497A3, 92497, 12449A1, 12449
SAE J1171



18-5967
ALTERNATOR
Serpentine Pulley • 55 Amp
Replaces: 807652T
SAE J1171



18-5966
ALTERNATOR
Single Groove Pulley • 55 Amp
Replaces: 817119A4, 12449A1, 98555A1, 92497, 817119A1, 12449A1, 12449
SAE J1171



18-5983
ALTERNATOR
Replaces: 862030T • SAE J1171
75I/70 amp, Hinge Mount, Single Groove Pulley



18-6293
ALTERNATOR
Replaces: 862031T, 862031T1 • SAE J1171
75I/70 amp, Hinge Mount,
Serpentine Pulley 2.44" Diameter



18-6298
ALTERNATOR
Replaces: 863077T • SAE J1171
75I/70 amp, Hinge Mount,
Serpentine Pulley 1.97" Diameter



18-6841
ALTERNATOR
Replaces: 56045, 59755, 69729, 78403A2, 78403A1, 78477, 90794
For: 37-63A Marine Applications



18-6842
ALTERNATOR
Replaces: 56045, 59755, 69729, 78403A2, 78403A1, 78477, 90794
For: 37-63A Marine Applications



18-6844
ALTERNATOR
Replaces: Mercruiser 834832, T2, 857006A3, Denso 101211-3460



18-6948
ALTERNATOR
Replaces: 882571, 8M0084523
Fits: CMD 1.7 MI 120 I/L4, CMD 1.7 MS 120 I/L4, D1.7L DTI



18-6960
ALTERNATOR
Replaces: Mercruiser 821663, 8216631, 821663A1
Denso 101211-3020, 3021



18-6975
ALTERNATOR (Universal)
Fits: High amp 160A alternator, universal mounting pattern based on Delco CS1300 design, v-belt and 6 groove serpentine pulley included

APPLICATION BEGINS ON NEXT PAGE



18-5953-1

ALTERNATOR CONVERSION KIT

Includes new 18-5956 68 AMP alternator, mounting brackets 18-5968, pulley (8.0" O.D. x 2.75" H), wiring, hardware and instructions. Converts model 470 aluminum block Mercuriser engines serial number 4625580 & up with stator charging system and water cooled voltage regulator to alternator system. **NOTE: Fuse kit 18-8220 (sold separately) is required on engines with a Delco starter (round solenoid mounted to starter); Prestolite starters with remote solenoid DO NOT require fuse kit. Visually inspect starter prior to ordering conversion kit. For: Mercuriser 224 / 3.7L.**



18-5949

CONVERSION KIT DRIVE BELT

3/8" x 33 1/2"
Replacement belt for alternator conversion kit used on 470 Series Mercurisers. Included in 18-5953-1 kit.



18-5968

ALTERNATOR BRACKET

Replacement bracket for alternator conversion kit used on 470 Series Mercuriser included in 18-5953-1 kit.



18-5978

ALTERNATOR BRACKET

Replaces: 47487T

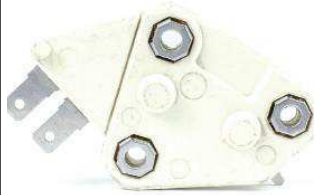

18-5724

VOLTAGE REGULATOR

Replaces: 78385



18-5740

VOLTAGE REGULATOR

Replaces: 42785



18-8220

FUSE KIT

Replaces: 88-79023A91
For use with 18-5953-1 alternator conversion kits installed on Mercuriser (Model 470) 3.7 liter aluminum block engines serial number 6902288 & Up. 90 AMP

Model	Cyl.	Years	Eng Serial #	End Serial #	Slave Solenoid	Reman Starter	New Starter	Reman Alternator	New Alternator
110	GM 4	1963-1966	1538370	2044033	18-5836	18-5911	18-5911	—	—
120	GM 4	1964-1975	1666601	4469865	18-5836	18-5911	18-5911	18-5957	18-5957
120	GM 4	1976-1982	4469866	6229717	18-5815	18-5911	18-5911	18-5957	18-5957
120 / 2.5L	GM 4	1983-1989	6229718	C853255	18-5817	18-5911	18-5911	—	18-5966 ④
140	GM 4	1968-1975	2508261	4460664	18-5836	18-5911	18-5911	18-5957	18-5957
140	GM 4	1976-1981	4460665	6229717	18-5815	18-5911	18-5911	18-5957	18-5957
140/3.0L	GM 4	1982-1989	6229718	C856558	18-5817	18-5911	18-5911	18-5957	18-5957
140/3.0L	GM 4	1999-2001	0L382122	0M326292	18-5817	—	18-6275	—	18-5983 **
140/3.0L/3.0LX	GM 4	1990-92	C856559	D831100	18-5817	18-5911	18-5911	18-5957	18-5957
140/3.0LX	GM 4	1992-97	D831101	OK999999	18-5817	N/A	18-6275	—	18-5966 ④
165/3.7L	Merc 4	1987-1989	B434941	C762299	18-5802	18-5907	18-5907	N/A	N/A
170	Merc 4	1985-1986	6916779	B434940	18-5802	18-5907	18-5907	N/A	N/A
180/3.7LX	Merc 4	1987-1989	B436391	C762299	18-5802	18-5907	18-5907	N/A	N/A
190	Merc 4	1985-1986	6916779	B436390	18-5802	18-5907	18-5907	N/A	N/A
470	Merc 4	1976-1984	4208730	6916778	18-5802	18-5907	18-5907	N/A	N/A
470MIE	Merc 4	1980-1981	5520115	6218036	18-5802	18-5907	18-5907	N/A	N/A
485	Merc 4	1980-1984	5685394	6916778	18-5802	18-5907	18-5907	N/A	N/A
140	GM 6	1963	1538930	1725960	18-5836	18-5911	18-5911	—	—
150	GM 6	1964-66	1666495	2048046	18-5836	18-5911	18-5911	—	—
160	GM 6	1967-69	2048022	2768031	18-5836	18-5911	18-5911	—	—
160	GM 6	1969	2768032	2770031	18-5836	18-5911	18-5911	18-5957	18-5957
165	GM 6	1970-1975	2770032	4471565	18-5836	18-5911	18-5911	18-5957	18-5957
165	GM 6	1976-1981	4471566	5813433	18-5815	18-5911	18-5911	18-5957	18-5957
200	GM 6	1969	2453769	2712072	18-5836	18-5911	18-5911	—	—
175/4.3L	GM V-6	1987-1992	B527955	D714106	18-5816	—	18-5913	—	18-5966 ④
185	GM V-6	1983-1984	6330183	6919655	18-5816	18-5911	18-5911	—	18-5966 ④

① For 12 3/4" Dia. Flywheel
 ② For 14" Dia. Flywheel
 ③ For permanent magnet models use 18-5919
 ④ 55 AMP up grade to 65 AMP use 18-5965
 ⑤ Black
 ⑥ For permanent magnet models use 18-5913
 ⑦ Bravo drive

⑧ Firepower ignition
 ⑨ Ignition module mounted on distributor
 ⑩ Ignition module mounted on elbow
 ⑪ LH rotation
 ⑫ NLA for models prior to S/N 4167000
 ⑬ PG 260 (9-1/4" long)
 ⑭ PG260F1 (8-1/2" long)

⑮ RH Rotation
 ⑯ Standard ignition
 ⑰ Thunderbolt ignition
 ⑱ Thunderbolt IV
 ⑲ Thunderbolt V
 ⑳ Transmission models
 ** Delco Style

Model	Cyl.	Years	Beg Serial #	End Serial #	Slave Solenoid	Reman Starter	New Starter	Reman Alternator	New Alternator
185	GM V-6	1985-1987	A331455	B527954	18-5816	N/A	18-5913	—	18-5966 ④
205	GM V-6	1985-1991	A331455	D714369	18-5816	N/A	18-5913	—	18-5966 ④
262 Mag. EFI	GM V-6	1996-1997	F803800	K999999	18-5817	N/A	18-5913	—	18-5960
262 Mag. EFI	GM V-6	1996-1997	F803800	K999999	18-5817	N/A	18-5913	—	18-5960
4.3L/LX/LXH	GM V-6	1992-1997	D714107	K999999	18-5817	—	18-5913	—	18-5967
4.3L/LX/LXH	GM V-6	1996-1997	F803000	K999999	18-5817	—	18-5913	—	18-5967
4.3L/LH	GM V-6	1998-99	L010044	OL618999	18-5817	—	18-5913	—	18-5967
4.3L/LH(Gen +)	GM V-6	2000-02	OL619000	OM320024	18-5817	—	18-5913	—	18-6293 **
4.3EFI	GM V-6	1998-99	L012009	OL618999	18-5817	—	18-5913	—	18-5960
4.3L EFI	GM V-6	2000-01	OL619000	OM299999	18-5817	—	18-5913	—	18-6293 **
4.3L MPI	GM V-6	2002	OM300000	OM320024	18-5817	—	18-5913	—	18-6293 **
190	GM V-8	1963-1964	1564539	1730903	18-5836	18-5911	18-5911	—	—
200	GM V-8	1985-1986	6218462	B525981	18-5816	18-5911	18-5911 ① ③	—	18-5966 ④
200	GM V-8	1985-1986	6218462	B525981	18-5816	18-5910	18-5910 ② ⑥	—	18-5966 ④
200/5.0L	GM V-8	1987-1995	B525982	F600999	18-5816	18-5910	18-5910	—	18-5966 ④
200/5.0L	GM V-8	1987-1995	B525982	F600999	18-5817	18-5910	18-5910	—	18-5966 ④
215 MCM &MIE	Ford V-8	1970-1972	2781153	3563181	18-5836	18-5908	18-5908 ①	18-5957	18-5957
215 MCM &MIE	Ford V-8	1970-1972	2781153	3563181	18-5836	18-5907	18-5907 ⑤	18-5957	18-5957
225	Ford V-8	1973-1974	3385721	4166999	18-5802	18-5903	—	18-5957	18-5957
225 MIE	Ford V-8	1973-1974	3385721	4176999	18-5836	18-5908	18-5908 ①	18-5957	18-5957
225 MIE	Ford V-8	1973-1974	3385721	4176999	18-5836	18-5907	18-5907 ⑤	18-5957	18-5957
888	Ford V-8	1971-1977	3108723	4612109	18-5802	18-5903	— ②	18-5957	18-5957
888	Ford V-8	1971-1977	4612110	& Up	18-5801	18-5903	—	18-5957	18-5957
225	GM V-8	1963-1966	1539620	2278646	18-5836	18-5911	18-5911	—	—
225 MIE	GM V-8	1968	2278647	2694014	18-5836	18-5908	18-5908 ①	—	—
225 MIE	GM V-8	1968	2278647	2694014	18-5836	18-5907	18-5907 ⑤	—	—
225	GM V-8	1967-1969	2278647	2694014	18-5836	—	—	—	—
228/230	GM V-8	1977-1986	4765100	B525981	18-5816	18-5911	18-5911 ① ③	—	18-5966 ④
228/230	GM V-8	1977-1986	4765100	B525981	18-5816	18-5910	18-5910 ② ⑥	—	18-5966 ④
228 MIE	GM V-8	1977-1980	4765100	5907057	18-5815	18-5908	18-5908 ①	18-5957	18-5957
228 MIE	GM V-8	1977-1980	4765100	5907057	18-5815	18-5907	18-5907 ⑤	18-5957	18-5957
230/5.0LX	GM V-8	1987-1995	B525982	F600999	18-5816 ⑩	18-5910	18-5910 ③	—	18-5966 ④
230/5.0LX	GM V-8	1987-1995	B525982	F600999	18-5817 ⑨	18-5910	18-5910 ③	—	18-5966 ④
230/5.0L MIE	GM V-8	1987-1988	5907058	B788151	18-5816	18-5908	18-5908 ①	—	18-5966 ④
230/5.0L MIE	GM V-8	1987-1988	5907058	B788151	18-5816	18-5907	18-5907 ⑤	—	18-5966 ④
5.0L(Gen +)	GM V-8	1998-99	L015751	L618999	18-5817	—	18-5913	—	18-5967
5.0L(Gen +)	GM V-8	2000-2002	L619000	M320024	18-5817	—	18-5913	—	18-6293 **
5.0L EFI	GM V-8	1998-99	L012052	L618999	18-5817	—	18-5913	—	18-5960
5.0L EFI	GM V-8	2000-01	L619000	M299999	18-5817	—	18-5913	—	18-6293 **
5.0L MPI	GM V-8	2002	M300000	M320024	18-5817	—	18-5913	—	18-6293 **
198 MIE	GM V-8	1977	4762210	6218461	18-5815	18-5908	18-5908 ①	18-5957	18-5957
198 MIE	GM V-8	1977	4762210	6218461	18-5815	18-5907	18-5907 ⑤	18-5957	18-5957
898	GM V-8	1977-1982	4762210	6218461	18-5801	18-5911	18-5911	18-5957	18-5957

① For 12 3/4" Dia. Flywheel
 ② For 14" Dia. Flywheel
 ③ For permanent magnet models use 18-5919
 ④ 55 AMP up grade to 65 AMP use 18-5965
 ⑤ Black
 ⑥ For permanent magnet models use 18-5913
 ⑦ Bravo drive

⑧ Firepower ignition
 ⑨ Ignition module mounted on distributor
 ⑩ Ignition module mounted on elbow
 ⑪ LH rotation
 ⑫ NLA for models prior to S/N 4167000
 ⑬ PG 260 (9-1/4" long)
 ⑭ PG260F1 (8-1/2" long)

⑮ RH Rotation
 ⑯ Standard ignition
 ⑰ Thunderbolt ignition
 ⑱ Thunderbolt IV
 ⑲ Thunderbolt V
 ⑳ Transmission models
 ** Delco Style

Model	Cyl.	Years	Beg Serial #	End Serial #	Slave Solenoid	Reman Starter	New Starter	Reman Alternator	New Alternator
898	GM V-8	1983-1984	621462	B525981	18-5816	18-5911	18-5911 ① ③	—	18-5966 ④
898	GM V-8	1983-1984	621462	B525981	18-5816	18-5910	18-5910 ② ⑥	—	18-5966 ④
233	Ford V-8	1975-1977	4173000	4902304	18-5801	18-5903	—	18-5957	18-5957
233 MIE	Ford V-8	1975-1976	4173000	4775784	18-5836	18-5908 ①	18-5908 ①	18-5957	18-5957
233 MIE	Ford V-8	1975-1976	4173000	4775784	18-5836	18-5907	18-5907 ②	18-5957	18-5957
250 MCM & MIE	GM V-8	1968-1969	2314301	2639854	18-5836	18-5908	18-5908 ①	—	—
250 MCM & MIE	GM V-8	1968-1969	2314301	2639854	18-5836	18-5907	18-5907 ②	—	—
250	GM V-8	1977	4768000	4908849	18-5801	18-5911	18-5911	18-5957	18-5957
255	Ford V-8	1973-1974	3258728	4175499	18-5802	18-5903	—	18-5957	18-5957
255 MIE	Ford V-8	1973-1974	3258728	4178299	18-5836	18-5908	18-5908 ①	18-5957	18-5957
255 MIE	Ford V-8	1973-1974	3258728	4178299	18-5836	18-5907	18-5907 ②	18-5957	18-5957
255	GM V-8	1975-1976	4175500	4767999	18-5815	18-5911	18-5911	18-5957	18-5957
255 MIE	GM V-8	1975-1980	4175500	5907057	18-5815	18-5908	18-5908 ①	18-5957	18-5957
255 MIE	GM V-8	1975-1980	4175500	5907057	18-5815	18-5907	18-5907 ②	18-5957	18-5957
260	GM V-8	1978-1982	4908850	6218461	18-5801	18-5911	18-5911	18-5957	18-5957
260	GM V-8	1982-1986	6218462	B525981	18-5816	18-5911	18-5911 ① ③	—	18-5966 ④
260	GM V-8	1982-1986	6218462	B525981	18-5816	18-5910	18-5910 ② ⑥	—	18-5966 ④
260/5.7L	GM V-8	1987-1995	B525982	F600999	18-5816 ⑩	18-5910	18-5910 ⑥	—	18-5966 ④
260/5.7L	GM V-8	1987-1995	B525982	F600999	18-5817 ⑨	18-5910	18-5910 ⑥	—	18-5966 ④
260/5.7L MIE	GM V-8	1987-1995	5907058	F746099	18-5816	18-5908	18-5908 ①	—	18-5966 ④
260/5.7L MIE	GM V-8	1987-1995	5907058	F746099	18-5816	18-5907	18-5907 ②	—	18-5966 ④
5.7L/LX	GM V-8	1996	F601000	K001526	18-5817	—	18-5913	—	18-5966 ④
5.7L/LX	GM V-8	1997 & Up	K001527	& Up	18-5817	—	18-5913	—	18-5967
5.7L	GM V-8	2000-02	L619000	M320024	18-5817	—	18-5913	—	18-6293 **
5.7L/LX EFI	GM V-8	1995-1996	F225560	K001505	18-5816	—	18-5913	—	18-5965
5.7L/LX EFI	GM V-8	1997	K001506	K999999	18-5816	—	18-5913	—	18-5960
5.7L EFI	GM V-8	1998 & Up	L010035	& Up	18-5816	—	18-5913	—	18-5960
5.7L EFI	GM V-8	2000-01	L619000	M299999	18-5816	—	18-5913	—	18-6293 **
5.7L MIE	GM V-8	1994-1996	F622151	K040306	18-5816	18-5908	18-5908 ①	—	18-5966 ④
5.7L MIE	GM V-8	1994-1996	F622151	K040306	18-5816	18-5907	18-5907 ②	—	18-5966 ④
5.7L MIE	GM V-8	1997 & Up	K040307	& Up	18-5817	18-5908	18-5908	—	18-5967
5.7L MIE	GM V-8	1998-01	L002003	L677226	18-5817	18-5908	18-5908	—	18-6293 **
5.7L EFI MIE	GM V-8	1997	K040300	K999999	18-5816	18-5908	18-5908	—	18-5960
5.7L Ski	GM V-8	1985-1995	A338533	F775199	18-5816	—	18-5913 ③	—	18-5966 ④
5.7L Ski	GM V-8	1985-1995	A338533	F775199	18-5816	18-5907	18-5907 ①	—	18-5966 ④
5.7L Ski	GM V-8	1996	F775200	K040003	18-5817	—	18-5913	—	18-5966 ④
5.7L Ski	GM V-8	1997	K040004	K999999	18-5817	—	18-5913	—	18-5967
5.7L Ski	GM V-8	1998 & Up	L002005	& Up	18-5817	—	18-5913	—	18-5967
5.7L Ski	GM V-8	2000-01	L619000	L678784	18-5817	—	18-5913	—	18-6293 **
350 Mag. Alpha	GM V-8	1986-1995	A635178	F600999	18-5816 ⑩	18-5910	18-5910 ⑥	—	18-5966 ④
350 Mag. Alpha	GM V-8	1987-1996	B525982	K001526	18-5817 ⑨	18-5910	18-5910 ⑥	—	18-5966 ④
350 Mag. Alpha	GM V-8	1997	K001527	K999999	18-5817	—	18-5913	—	18-5967
350 Mag. EFI & MPI	GM V-8	1995-1996	F415189	K001500	18-5816	—	18-5913	—	18-5965
350 Mag. EFI & MPI	GM V-8	1997 & Up	K001501	& Up	18-5816	—	18-5913	—	18-5960

① For 12 3/4" Dia. Flywheel
 ② For 14" Dia. Flywheel
 ③ For permanent magnet models use 18-5919
 ④ 55 AMP up grade to 65 AMP use 18-5965
 ⑤ Black
 ⑥ For permanent magnet models use 18-5913
 ⑦ Bravo drive

⑧ Firepower ignition
 ⑨ Ignition module mounted on distributor
 ⑩ Ignition module mounted on elbow
 ⑪ LH rotation
 ⑫ NLA for models prior to S/N 4167000
 ⑬ PG 260 (9-1/4" long)
 ⑭ PG260F1 (8-1/2" long)

⑮ RH Rotation
 ⑯ Standard ignition
 ⑰ Thunderbolt ignition
 ⑱ Thunderbolt IV
 ⑲ Thunderbolt V
 ⑳ Transmission models
 ** Delco Style

Model	Cyl.	Years	Beg Serial #	End Serial #	Slave Solenoid	Reman Starter	New Starter	Reman Alternator	New Alternator
350 Mag MPI	GM V-8	2000-01	L619000	M299999	18-5816		18-5913		18-6293 **
350 Mag MPI / Horizon	GM V-8	2002	M300000	M320024	18-5817		18-5913		18-6293 **
350 Mag MPI MIE	GM V-8	1998 & Up	L002008	& Up	18-5816	18-5908	18-5908	—	18-5960
350 Mag MPI MIE / Horizon	GM V-8	1999-01	L304700	L678398	18-5816	18-5908	18-5908		18-6293 **
350 Mag Ski	GM V-8	1991-1996	D505450	K040399	18-5816 ①	—	18-5913	—	18-5966 ④
350 Mag Ski	GM V-8	1991-1996	D505450	K040399	18-5817 ②	—	18-5913	—	18-5966 ④
350 Mag Ski	GM V-8	1997	K040400	K999999	18-5817	—	18-5913	—	18-5967
350 Mag EFI Ski	GM V-8	1994-1997	F215561	K999999	18-5816	—	18-5913	—	18-5965
350 Mag MPI Ski	GM V-8	1995-1996	F350583	F799999	18-5816	—	18-5913	—	18-5965
350 Mag MPI Ski	GM V-8	1998 & Up	L002600	& Up	18-5817	—	18-5913	—	18-5960
350 Mag MPI Ski	GM V-8	1998-02	L002600	M310021	18-5817	—	18-5913	—	18-6293 **
Black Scorpion	GM V-8	1996	F800000	K040000	18-5816	—	18-5913	—	18-5965
Black Scorpion	GM V-8	1997 & Up	K040001	& Up	18-5816	—	18-5913 ③	—	18-5960
Black Scorpion	GM V-8	1997 & Up	K040001	& Up	18-5816	—	18-5913 ④	—	18-5960
Black Scorpion	GM V-8	1997-01	K040001	L678036	18-5816	—	18-5913	—	18-6293 **
270 MCM & MIE	GM V-8	1969-1972	2851074	3385720	18-5836	18-5908	18-5908 ①	18-5957	18-5957
270 MCM & MIE	GM V-8	1969-1972	2851074	3385720	18-5836	18-5907	18-5907 ②	18-5957	18-5957
280 TRS	GM V-8	1975-1976	4176250	4770199	18-5815	18-5911	18-5911	18-5957	18-5957
300 TR TEMPEST	GM V-8	1985-1986	6668677	B430367	18-5816	18-5908	18-5908	—	18-5966 ④
300 MR TEMPEST	GM V-8	1985-1986	6668677	B430367	18-5816	—	18-5919 ①	—	18-5966 ④
300 MR TEMPEST	GM V-8	1985-1986	6668677	B430367	18-5816	—	18-5913 ②	—	18-5966 ④
320 EFI	GM V-8	1987-1989	A543604	C622418	18-5816	—	18-5913	—	18-5966 ④
MX 6.2L MPI	GM V-8	2000-2002	L680003	M320024	18-5817	—	18-5913	—	18-6293
MX 6.2L MPI Horizon	GM V-8	2002	M300000	M320024	18-5817	—	18-5913	—	18-6293
MX 6.2L MPI Horizon MIE	GM V-8	2002	M300000	M310099	18-5817	—	18-5603	—	18-6293
MX 6.2L MPI MIE	GM V-8	2002	M300000	M310099	18-5817	—	18-5603	—	18-6293
MX 6.2L Black Scorpion Ski	GM V-8	2001	L670015	L678036	18-5816	—	18-5913	—	18-6293
325 MCM & MIE	GM V-8	1968-1970	2278747	2761141	18-5836	18-5908	18-5908 ①	—	—
325 MCM & MIE	GM V-8	1968-1970	2278747	2761141	18-5836	18-5907	18-5907 ②	—	—
325 MCM & MIE	GM V-8	1970-1974	2761142	3780449	18-5836	18-5908	18-5908 ①	18-5957	18-5957
325 MCM & MIE	GM V-8	1970-1974	2761142	3780449	18-5836	18-5907	18-5907 ②	18-5957	18-5957
330	GM V-8	1977-1981	4623115	6083144	18-5836 ③	—	18-5913	18-5957	18-5957
330	GM V-8	1977-1981	4623115	6083144	18-5815 ④	—	18-5913	18-5957	18-5957
330	GM V-8	1982-1987	6083145	B816540	18-5816	18-5908	18-5908	—	18-5966 ④
330 MIE	GM V-8	1977-1980	4623115	5889913	18-5836 ⑤	18-5908	18-5908 ①	18-5957	18-5957
330 MIE	GM V-8	1977-1980	4623115	5889913	18-5815 ⑥	18-5907	18-5907 ②	18-5957	18-5957
340/7.4L MIE w/BW	GM V-8	1981-1992	5889914	D715493	18-5816	18-5908	18-5908 ①	—	18-5966 ④
340/7.4L MIE w/BW	GM V-8	1981-1992	5889914	D715493	18-5816	18-5907	18-5907 ②	—	18-5966 ④
7.4L	GM V-8	1988-1991	B771113	D603117	18-5816	18-5910	18-5910 ③	—	18-5966 ④
7.4L	GM V-8	1988-1996	B771113	F800699	18-5816 ④	18-5910	18-5910 ③	—	18-5966 ④
7.4L	GM V-8	1992-1997	D603118	K999999	18-5817 ⑤	—	18-5913	—	18-5966 ④
7.4LX EFI & MPI	GM V-8	1996-1997	F602010	K999999	18-5816	—	18-5913	—	18-5965
7.4L MPI	GM V-8	1998 & Up	L010003	& Up	18-5817	—	18-5913	—	18-6293
7.4L MIE	GM V-8	1989-1996	C391564	F820141	18-5816 ⑥	18-5908	18-5908	—	18-5966 ④
7.4L MIE	GM V-8	1992-1997	D715494	K999999	18-5817 ⑦	18-5908	18-5908	—	18-5966 ④
7.4L EFI & MPI MIE	GM V-8	1995-1997	F563052	K999999	18-5816	18-5908	18-5908	—	18-5965
7.4L MPI MIE	GM V-8	1998 & Up	L002006	& Up	18-5817	18-5908	18-5908	—	18-6293
350 MIE	GM V-8	1974-1976	3780450	4623109	18-5836	18-5908	18-5908 ①	18-5957	18-5957
350 MIE	GM V-8	1974-1976	3780450	4623109	18-5836	18-5907	18-5907 ②	18-5957	18-5957

① For 12 3/4" Dia. Flywheel
 ② For 14" Dia. Flywheel
 ③ For permanent magnet models use 18-5919
 ④ 55 AMP up grade to 65 AMP use 18-5965
 ⑤ Black
 ⑥ For permanent magnet models use 18-5913
 ⑦ Bravo drive

⑧ Firepower ignition
 ⑨ Ignition module mounted on distributor
 ⑩ Ignition module mounted on elbow
 ⑪ LH rotation
 ⑫ NLA for models prior to S/N 4167000
 ⑬ PG 260 (9-1/4" long)
 ⑭ PG260F1 (8-1/2" long)

⑮ RH Rotation
 ⑯ Standard ignition
 ⑰ Thunderbolt ignition
 ⑱ Thunderbolt IV
 ⑲ Thunderbolt V
 ⑳ Transmission models
 ** Delco Style

Model	Cyl.	Years	Beg Serial #	End Serial #	Slave Solenoid	Reman Starter	New Starter	Reman Alternator	New Alternator
370 TRS	GM V-8	1978-1985	4179554	6721527	18-5815	18-5908	18-5908	18-5957	18-5957
370 TRS	GM V-8	1978-1985	4179554	6721527	18-5815	18-5908	18-5908	—	18-5966 ④
370 TRS	GM V-8	1985-1987	6721528	B714586	18-5816	18-5908	18-5908	—	18-5966 ④
390 MCM & MIE	GM V-8	1969-1970	2781129	3042731	18-5836	18-5908	18-5908 ①	18-5957	18-5957
390 MCM & MIE	GM V-8	1969-1970	2781129	3042731	18-5836	18-5907	18-5907 ②	18-5957	18-5957
400 TRS	GM V-8	1980-1986	4179554	B457644	18-5815	18-5908	18-5908	18-5957	18-5957
400 TRS	GM V-8	1980-1986	4179554	B457644	18-5815	18-5908	18-5908	—	18-5966 ④
420	GM V-8	1987-1989	A398941	B622418	18-5816	18-5908	18-5908	—	18-5966 ④
425	GM V-8	1990-1992	A398941	D937011	18-5816	18-5908	18-5908	—	18-5966 ④
440 TRS	GM V-8	1983-1986	4179554	B485220	18-5815	18-5908	18-5908	18-5957	18-5957
440 TRS	GM V-8	1983-1986	4179554	B485220	18-5815	18-5908	18-5908	—	18-5966 ④
450	GM V-8	1995-1996	F347100	F347277	18-5820	—	18-5913	—	—
454 Mag.	GM V-8	1986-1994	A631894	F304999	18-5816	—	18-5913	—	18-5966 ④
454 Mag.	GM V-8	1995-1997	F305000	K999999	18-5817	—	18-5913	—	18-5966 ④
454 Mag. MPI	GM V-8	1994-1997	F115700	K999999	18-5816	—	18-5913	—	18-5965
454 Mag. MPI	GM V-8	1998 & Up	L010029	& Up	18-5816	—	18-5913	—	18-6293
454 Mag. MPI MIE	GM V-8	1996-1997	F820100	K999999	18-5816	—	18-5913	—	18-5965
454 Mag. MPI MIE	GM V-8	1998 & Up	L002200	& Up	18-5816	18-5908	18-5908	—	18-6293
454 EFI Ski	GM V-8	1995-1996	F215800	F820099	18-5816	—	18-5913	—	18-5965
460 TRS	GM V-8	1983-1986	4179554	6181046	18-5815	18-5908	18-5908	18-5957	18-5957
460 TRS	GM V-8	1983-1986	4179554	6181046	18-5815	18-5908	18-5908	—	18-5966 ④
465	GM V-8	1990-1994	C849992	F213244	18-5816 ③	—	18-5913 ⑦	—	18-5966 ④ ⑤
465	GM V-8	1990-1994	C849992	F213244	—	18-5908	18-5908 ⑩	—	—
500	GM V-8	1994-1997	F213293	& Up	18-5820	—	18-5913 ⑦	—	—
500	GM V-8	1994-1995	F213293	& Up	18-5820	18-5908	18-5908 ⑩	—	—
500 Bulldog	GM V-8	1990-1996	C577254	& Up	18-5820 ⑧	—	18-5913 ⑦	—	—
500 Bulldog	GM V-8	1990-1996	C577254	& Up	18-5816 ⑧	18-5908	18-5908 ⑩	—	18-5966 ④ ⑤
502 Mag. Bravo	GM V-8	1990-1993	C878221	F114528	18-5816	—	18-5913	—	18-5966 ④
502 Mag. MPI	GM V-8	1993-1997	D840650	K999999	18-5816	—	18-5913	—	18-5965
502 Mag. MPI	GM V-8	1998 & Up	L017000	& Up	18-5816	—	18-5913	—	18-6293
525 SC	GM V-8	1991-1993	D456000	D763831	18-5816	—	18-5913 ⑦	—	18-5966 ④ ⑤
525 SC	GM V-8	1991-1993	D456000	D763831	18-5816	18-5908	18-5908 ⑩	—	—
525 SC	GM V-8	1993-1997	D763871	& Up	18-5820	—	18-5913 ⑦	—	18-5966 ④ ⑤
525 SC	GM V-8	1993-1997	D763871	& Up	18-5820	18-5908	18-5908 ⑩	—	—
525 EFI	GM V-8	2003-2010	M900146	& Up	—	—	—	—	18-6298
575	GM V-8	1986-1992	A677429	D763716	18-5816	18-5908	18-5908	—	18-5966 ④
600 SC	GM V-8	1991-1996	D456489	F877642	18-5816 ⑧	18-5908	18-5908	—	18-5966 ④ ⑤
600 SC	GM V-8	1991-1996	D456489	F877642	18-5820 ⑧	18-5908	18-5908	—	—
600 SC	GM V-8	1997	K000227	& Up	18-5820	—	18-5913 ⑩	—	—
600 Sci	GM V-8	2005-2010	M952908	& Up	—	—	—	—	18-6298
800 SC	GM V-8	1993-1996	D763836	& Up	18-5820	18-5908	18-5908 ⑩	—	—
8.2L MIE	GM V-8	1990-1996	C878221	F819619	18-5816 ⑨	18-5908	18-5908	—	18-5966 ④
8.2L MIE	GM V-8	1993-1996	D857200	F819619	18-5817	18-5908	18-5908	—	18-5966 ④
8.2L MPI MIE	GM V-8	1996-1997	F819620	K999999	18-5816	18-5908	18-5908	—	18-5965
8.2L MPI MIE	GM V-8	1998 & Up	L002450	& Up	18-5816	18-5908	18-5908	—	18-6293

① For 12 3/4" Dia. Flywheel
 ② For 14" Dia. Flywheel
 ③ For permanent magnet models use 18-5919
 ④ 55 AMP up grade to 65 AMP use 18-5965
 ⑤ Black
 ⑥ For permanent magnet models use 18-5913
 ⑦ Bravo drive

⑧ Firepower ignition
 ⑨ Ignition module mounted on distributor
 ⑩ Ignition module mounted on elbow
 ⑪ LH rotation
 ⑫ NLA for models prior to S/N 4167000
 ⑬ PG 260 (9-1/4" long)
 ⑭ PG260F1 (8-1/2" long)

⑮ RH Rotation
 ⑯ Standard ignition
 ⑰ Thunderbolt ignition
 ⑱ Thunderbolt IV
 ⑲ Thunderbolt V
 ⑳ Transmission models
 ** Delco Style



18-7683
FUEL PRESSURE REGULATOR
Replaces: 849899
Fits: MCM 500 EFI



18-7663
FUEL PRESSURE REGULATOR
Replaces: 802630T01, 802630001, 802630T, 802630, 8M0069803
Fits: 7.4L MPI (L29)



18-33207
FUEL PRESSURE REGULATOR
Replaces: 860349A1
Fits: MCM/MIE 7.4L/LX MPI, 4545 Mag MPI, 502 Mag MPI, MIE 8.2L MPI. Mounts on Fuel Cooler.



18-33211
FUEL PRESSURE REGULATOR
Replaces: 892681
Fits: Mercruiser 8.1L, 496 Mag HO, 502 Mag MPI 375-400 HP.



18-7600
TEMPERATURE SENSOR
Replaces: 805218T



18-7700
THROTTLE POSITION SENSOR
Replaces: 853678T
Fits: MCM/MIE 4.3L MPI, 5.0L MPI, MX6.2L MPI w/ECM 555 and 350 Mag MPI, Black Scorpion Tow Sports, 377 Scorpion Tow Sports, 7.4L MPI(L29) & MCM 496 Mag & HO and MIE 8.1S & HO



18-7630
THROTTLE POSITION SENSOR
Replaces: 805226A1



18-7701
IDLE SPEED CONTROL MOTOR
Replaces: 862998
Fits: MCM 3.0L MPI, V6 & V8(305, 350 & 496 cid)MPI engines w/ECM555 (Includes gasket)



18-7697
IAC MOTOR
Replaces: 803149
Fits: MCM/MIE 350 Mag MPI, Black Scorpion Tow Sports, 377 Scorpion MCM & Tow Sports, MX6.2L MPI, 7.4L MPI(L29) & 575 Sci



18-7632-1
IDLE AIR CONTROL MOTOR
Replaces: 805224A1



18-33800
PCV VALVE
Replaces: 21-806118
Fits: MCM 262 Mag EFI, 4.3L EFI



18-7682
MAP SENSOR
Replaces: 849934, 879150150
Fits: MCM 575 Sci



18-7684
MAP SENSOR
Replaces: 864856A1, 805217A1
Fits: MCM/MIE GM V6 & V8 (350, 377, 454 & 502cid)EFI Engines



18-7660
MAP SENSOR
Replaces: 881731, 8M0054726
Fits: V-6 & V-8 MPI engines with 555 ECM



18-7550
MAP SENSOR
Replaces: 861249, 861249A1
Fits: Mercury 5.7L, 7.4L 1998-2001



18-7551
MAP SENSOR
 Replaces: 861425
 Fits: Mercury Scorpion,
 Black Scorpion 1998-2010



18-7668
MAP SENSOR
 Replaces: 854445
 525 EFI



18-7553
KNOCK SENSOR
 Replaces: 808015T
 Fits: Mercury 5.7L MAG 1998-2010



18-7554
KNOCK SENSOR
 Replaces: 878187
 Fits: Mercury 5.7L MAG 1994-2010



18-7677
KNOCK SENSOR
 Replaces: 806612T
 Fits: GM V8(305, 350 & 377 cid) engines



18-7703
KNOCK SENSOR
 Replaces: 805544T



18-7646
CAMSHAFT SENSOR
 Replaces: 892615002, 892615001, 892615



18-7685
TBI INJECTOR
 Replaces: 852956A1
 Fits: MCM GM V6 & V8 (305 & 350 cid) TBI engines



18-7757
THROTTLE POSITION SENSOR
 Replaces: 803148
 For: 350 Mag OL005900 & Up



18-33104
FUEL INJECTOR
 Replaces: 802632T, 802632
 Fits: MCM/MIE 7.4L MPI L29



18-7688
FUEL INJECTOR
 Replaces: 885176
 Fits: MCM 4.3L MPI engines (s/n OM300000-1A063239)
 & 5.0L, 5.7L & 6.2L MPI engines w/ ECM 555
 (s/n OM300000-1A064824)



18-7698
FUEL INJECTOR
 Replaces: 881693002
 Fits: MCM 496 Mag & HO and MIE 8.1S & HO



18-7690
INJECTOR SEAL KIT
Replaces: 27-852957
Use with Mercury Injector # 852956A1, 853998A1, 853998T, 853998
Fits: 262 Mag EFI (1996-97), 4.3L EFI (1998-01), 5.0L EFI (1998-01), 350 Mag Alpha EFI (Gen+) (1996-97), 350 Mag EFI SKI (1994-97), 5.7L EFI (1995-01), 5.7L EFI MIE (Gen+) (1997), 5.7L LX Bravo EFI (Gen+) (1996-97), 5.7 LX EFI (1995-97), 7.4L LX TBI (1996-97), 575 Sci (2000-05)



18-7691
INJECTOR SEAL KIT
Use with Mercury Injector # 806807A1
Fits: 350 Mag Bravo MPI (1995-96), Black Scorpion SKI (1996)



18-7692
INJECTOR SEAL KIT
Use with Mercury Injector # 861260T, 861260
Fits: 350 Mag MPI(98-01), 350 Mag MPI Horizon MIE(98-01), 350 Mag MPI MIE(98-01), 350 Mag MPI SKI(98-01), MX 6.2L MPI(00-01), 454 Mag MPI(99-01), 454 Mag MPI Horizon MIE(99-01), 502 Mag MPI(99-01), 8.2L MPI(99-01)



18-7693
INJECTOR SEAL KIT
Use with Mercury Injector # 802632T, 849896
Fits: 7.4L MPI(L29)(98-01), 7.4L MPI MIE(L29)(98-01), 500 EFI(99-05)



18-7694
INJECTOR SEAL KIT
Use with Mercury Injector # 881693002
Fits: 496 Mag (2001-08), 496 Mag DTS (2001-08), 496 Mag HO (2001-08), 496 Mag HO DTS (2001-08), 8.1L MIE (2001-08), 496 Mag DTS (2001-08), 8.1L HO MIE (2001-08), 496 Mag HO DTS (2001-08)



18-7695
INJECTOR SEAL KIT
Use with Mercury Injector # 885176
Fits: 4.3L MPI(02-08), 5.0L MPI(02-08), 5.0L MPI DTS(05-08), 350 Mag MPI(02-08), 350 Mag MPI DTS(05-08), 350 Mag MPI Horizon(02-07), 350 Mag MPI Horizon DTS(05-07), 350 Mag MPI Horizon MIE(02-07), 350 Mag MPI MIE DTS(05-07), 350 Mag MPI SKI(02-07), 5.7L Horizon MIE(08), 5.7L MIE(08), 5.7L DTS MIE(08), 5.7L MPI SKI(08), MX6.2L MPI(02-07), MX6.2L MPI DTS(05-07), MX6.2L MPI Horizon(04-07), MX6.2L MPI Horizon DTS(05-07), MX6.2L MPI Horizon MIE(02-08), MX6.2L MPI Horizon MIE DTS(05-08), MX 6.2L MPI MIE(02-07), MX6.2L MPI MIE DTS(05-07), MX6.2L MPI SKI(02-07)



18-7696
INJECTOR SEAL KIT
Use with Mercury Injector # 805225A1
Fits: 320 EFI(87-89), 350 Mag Bravo MPI(Gen+)(97), Black Scorpion Ski(97-08), 377 Scorpion MCM(99-05), 377 Scorpion Ski(97-98), MX6.2L Black Scorpion Ski (01-07), 454 Mag EFI SKI(94-97), 454 Mag MPI(96-98), 454 Mag MPI Horizon MIE(98), 7.4L MPI MIE (95-97), 7.4LX MPI(96-97), 502 Mag MPI(93-98), 525 EFI(03-08), 8.2L MPI MIE(96-98)

FUEL INJECTION SYSTEM APPLICATION

Model	Liter	CID	# CYL	Year Range	Serial # Range	Injector	IAC Valve	TPS	F/P Regulator Rail-Mounted	F/P Regular Cooler Mounted	MAP Sensor
3.0L MPI	3.0L	181	L4	2008-2010	A072812 & UP	N/A	18-7701	N/A	N/A	N/A	N/A
262 MAG EFI	4.3L	262	V-6	1996-1997	F803800 - K999999	18-7685	18-7632-1	18-7630	N/A	N/A	18-7684
4.3L EFI	4.3L	262	V-6	1998-2001	L012009 - M299999	18-7685	18-7632-1	18-7630	N/A	N/A	N/A
4.3L MPI	4.3L	262	V-6	2002-2007	M300000 - A063239	18-7688	18-7701	18-7700	N/A	N/A	N/A ⊕
4.3L MPI	4.3L	262	V-6	2007-2010	A063240 & UP	N/A	18-7701	18-7700	N/A	N/A	N/A ⊕
5.0L EFI	5.0L	305	V-8	1998-2001	L012052 - M299999	18-7685	18-7632-1	18-7630	N/A	N/A	N/A
5.0L MPI	5.0L	305	V-6	2002-2007	M300000 - A064824	18-7688	18-7701	18-7700	N/A	N/A ⊕	N/A ⊕
5.0L MPI	5.0L	305	V-6	2007-2010	A064825 & UP	N/A	18-7701	18-7700	N/A	N/A ⊕	N/A ⊕
5.0L MPI DTS	5.0L	305	V-8	2005-2007	W310000 - A064824	18-7685	N/A	N/A	N/A	N/A	N/A
5.0L MPI DTS	5.0L	305	V-8	2010	A064825 & UP	N/A	N/A	N/A	N/A	N/A	N/A
350 MAG ALPHA EFI (GEN +)	5.7L	350	V-8	1996-1997	F800300 - K999999	18-7685	18-7632-1	18-7630	N/A	N/A	18-7684
350 MAG BRAVO MPI	5.7L	350	V-8	1995-1996	F415189 - K001500	N/A	18-7632-1	18-7630	N.L.A.	N/A	18-7684 ⊕
350 MAG BRAVO MPI (GEN +)	5.7L	350	V-8	1997	K001501 - K999999	N/A	18-7632-1	18-7630	N/A	N/A	18-7684 ⊕
350 MAG EFI SKI	5.7L	350	V-8	1994-1996	F215561 - F820706	18-7685	18-7632-1	18-7630	N/A	N/A	18-7684
350 MAG EFI SKI	5.7L	350	V-8	1996	F820707 - K040005	18-7685	18-7632-1	18-7630	N/A	N/A	18-7684
350 MAG MPI	5.7L	350	V-8	1998	L010019 - L331598	N/A	18-7697	18-7700	N/A	N/A	N/A
350 MAG MPI	5.7L	350	V-8	1998	L336000 - L346999	N/A	18-7697	18-7700	N/A	N/A	N/A
350 MAG MPI	5.7L	350	V-8	1999	L331599 - L335999	N/A	18-7697	18-7757	N/A	N/A	N/A
350 MAG MPI	5.7L	350	V-8	1999-2001	L340000 - M299999	N/A	18-7697	18-7757	N/A	N/A	N/A
350 MAG MPI	5.7L	350	V-8	2002-2007	M300000 - A064824	18-7688	18-7701	18-7700	N/A	N/A ⊕	N/A ⊕
350 MAG MPI DTS	5.7L	350	V-8	2005-2007	W310000 - A064824	18-7688	N/A	N/A	N/A	N/A	N/A ⊕
350 MAG MPI DTS	5.7L	350	V-8	2007-2010	A064825 & UP	N/A	N/A	N/A	N/A	N/A	N/A ⊕
350 MAG MPI HORIZON	5.7L	350	V-8	2002-2007	M300000 - A064824	18-7688	18-7701	18-7700	N/A	N/A ⊕	N/A ⊕
350 MAG MPI HORIZON	5.7L	350	V-8	2007	A064825 - A299999	N/A	18-7701	18-7700	N/A	N/A ⊕	N/A ⊕
350 MAG MPI HORIZON DTS	5.7L	350	V-8	2005-2007	W310000 - A064824	18-7688	N/A	N/A	N/A	N/A	N/A ⊕
350 MAG MPI HORIZON DTS	5.7L	350	V-8	2007	A064825 - A299999	N/A	N/A	N/A	N/A	N/A	N/A ⊕
350 MAG MPI HORIZON MIE	5.7L	350	V-8	1999-2001	L304700 - M299999	N/A	18-7697	18-7757	N/A	N/A	N/A
350 MAG MPI HORIZON MIE	5.7L	350	V-8	2002-2004	M300000 - M398371	18-7688	18-7701	18-7700	N/A	N/A	N/A ⊕

⊕ BRAVO APPS W/SN W060000, ORDER REGULATOR # 892681 ⊕ MAPT SENSOR (TEMP & PRESSURE)

FUEL INJECTION SYSTEM APPLICATION (CONT.)

Model	Liter	CID	# CYL	Year Range	Serial # Range	Injector	IAC Valve	TPS	F/P Regulator Rail-Mounted	F/P Regular Cooler Mounted	MAP Sensor
350 MAG MPI HORIZON MIE	5.7L	350	V-8	2004-2007	M398372 - A064824	18-7688	18-7701	18-7700	N/A	N/A	N/A Ⓞ
350 MAG MPI HORIZON MIE	5.7L	350	V-8	2007	A064825 - A089999	N/A	18-7701	18-7700	N/A	N/A	N/A Ⓞ
350 MAG MPI HORIZON MIE DTS	5.7L	350	V-8	2005-2007	W390000 - A064824	18-7688	N/A	N/A	N/A	N/A	N/A Ⓞ
350 MAG MPI HORIZON MIE DTS	5.7L	350	V-8	2007	A064825 - A089999	N/A	N/A	N/A	N/A	N/A	N/A Ⓞ
350 MAG MPI MIE	5.7L	350	V-8	1998	L002008 - L302199	N/A	18-7697	18-7700	N/A	N/A	N/A
350 MAG MPI MIE	5.7L	350	V-8	1999-2001	L302200 - M299999	N/A	18-7697	18-7757	N/A	N/A	N/A
350 MAG MPI MIE	5.7L	350	V-8	2002-2004	M300000 - M398371	18-7688	18-7701	18-7700	N/A	N/A	N/A Ⓞ
350 MAG MPI MIE	5.7L	350	V-8	2004-2007	M398372 - A064824	18-7688	18-7701	18-7700	N/A	N/A	N/A Ⓞ
350 MAG MPI MIE	5.7L	350	V-8	2007	A064825 - A089999	N/A	18-7701	18-7700	N/A	N/A	N/A Ⓞ
350 MAG MPI MIE DTS	5.7L	350	V-8	2005-2007	W390000 - A064824	18-7688	N/A	N/A	N/A	N/A	N/A Ⓞ
350 MAG MPI MIE DTS	5.7L	350	V-8	2007	A064825 - A089999	N/A	N/A	N/A	N/A	N/A	N/A Ⓞ
350 MAG EFI SKI	5.7L	350	V-8	1994-1996	F215561 - F820706	18-7685	18-7632-1	18-7630	N/A	N/A	18-7684
350 MAG MPI SKI	5.7L	350	V-8	1998	L002600 - L304599	N/A	18-7697	18-7700	N/A	N/A	N/A
350 MAG MPI SKI	5.7L	350	V-8	1999-2001	L304600 - M299999	N/A	18-7697	18-7757	N/A	N/A	N/A
350 MAG MPI SKI	5.7L	350	V-8	2002-2007	M300000 - A064824	N/A	18-7701	18-7700	N/A	N/A	N/A Ⓞ
350 MAG MPI SKI	5.7L	350	V-8	2007	A064825 - A089999	N/A	18-7701	18-7700	N/A	N/A	N/A ◆
5.7L EFI	5.7L	350	V-8	1995-1997	F225560 - K999999	18-7685	18-7632-1	18-7630	N/A	N/A	18-7684
5.7L EFI (GEN +)	5.7L	350	V-8	1998-2001	L010035 - M299999	18-7685	18-7632-1	18-7630	N/A	N/A	N/A
5.7L EFI MIE (GEN +)	5.7L	350	V-8	1997	K040300 - K999999	18-7685	18-7632-1	18-7630	N/A	N/A	18-7684
5.7L MPI HORIZON MIE	5.7L	350	V-8	2008-2010	A090000 - & UP	N/A	18-7701	18-7700	N/A	N/A	N/A ◆
5.7L MPI HORIZON DTS MIE	5.7L	350	V-8	2008-2010	A090000 - & UP	N/A	N/A	N/A	N/A	N/A	N/A ◆
5.7L MPI MIE	5.7L	350	V-8	2008-2010	A090000 - & UP	N/A	18-7701	18-7700	N/A	N/A	N/A ◆
5.7L MPI DTS MIE	5.7L	350	V-8	2008-2010	A090000 - & UP	N/A	N/A	N/A	N/A	N/A	N/A ◆
5.7L MPI SKI	5.7L	350	V-8	2008-2010	A090000 - & UP	N/A	N/A	18-7700	N/A	N/A	N/A ◆
5.7LX BRAVO EFI (GEN +)	5.7L	350	V-8	1996-1997	F800300 - K999999	18-7685	18-7632-1	18-7630	N/A	N/A	18-7684
5.7LX EFI	5.7L	350	V-8	1995-1997	F225560 - K999999	18-7685	18-7632-1	18-7630	N/A	N/A	18-7684
BLACK SCORPION SKI		350	V-8	1996	F350583 - K040000	N/A	18-7697	18-7700	N.L.A.	N.L.A.	18-7684
BLACK SCORPION SKI		350	V-8	1997	K040001 - L002699	N/A	18-7697	18-7700	N/A	N/A	18-7684
BLACK SCORPION SKI		350	V-8	1998	L002700 - L005600	N/A	18-7697	18-7700	N/A	N/A	N/A
BLACK SCORPION SKI		350	V-8	1998-2002	L005601 - M391599	N/A	18-7697	18-7757	N/A	N/A	N/A
BLACK SCORPION SKI		350	V-8	2003-2010	M391600 - W698432	N/A	18-7701	18-7757	N/A	N/A	N/A
SCORPION 350	5.0L	350	V-8	2008-2010	W698433 & UP	N/A	18-7701	18-7757	N/A	N/A	N/A
377 MAG		377	V-8	2008-2010	A300000 & UP	N/A	18-7701	18-7700	N/A	N/A	N/A ◆
377 MAG DTS		377	V-8	2008-2010	A300000 & UP	N/A	N/A	N/A	N/A	N/A	N/A ◆
377 SCORPION MCM		377	V-8	1999-2005	L416146 - M907201	N/A	18-7697	18-7757	N/A	N/A	18-7684
377 SCORPION SKI		377	V-8	1997-1998	K000656 - L600314	N/A	18-7697	18-7700	N/A	N/A	18-7684
MX 6.2L MPI	6.2L	377	V-8	2000-2001	L680003 - M299999	N/A	18-7697	18-7757	N/A	N/A	N/A
MX 6.2L MPI	6.2L	377	V-8	2002-2004	M300000 - W059999	18-7688	18-7701	18-7700	N/A	N/A	N/A ◆
MX 6.2L MPI	6.2L	377	V-8	2004-2007	W060000 - A064824	18-7688	18-7701	18-7700	N/A	N/A	N/A ◆
MX 6.2L MPI	6.2L	377	V-8	2007	A064825 - A299999	N/A	18-7701	18-7700	N/A	N/A	N/A ◆
MX 6.2L MPI DTS.	6.2L	377	V-8	2005-2007	W310000 - A064824	18-7688	N/A	N/A	N/A	N/A	N/A ◆
MX 6.2L MPI DTS.	6.2L	377	V-8	2007	A064825 - A299999	N/A	N/A	N/A	N/A	N/A	N/A ◆
MX 6.2L MPI HORIZON	6.2L	377	V-8	2002-2004	M300000 - W059999	18-7688	18-7701	18-7700	N/A	N/A	N/A ◆
MX 6.2L MPI HORIZON	6.2L	377	V-8	2004-2007	W060000 - A064824	18-7688	18-7701	18-7700	N/A	N/A	N/A ◆
MX 6.2L MPI HORIZON	6.2L	377	V-8	2007	A064825 - A299999	N/A	18-7701	18-7700	N/A	N/A	N/A ◆
MX 6.2L MPI HORIZON DTS	6.2L	377	V-8	2005-2007	W310000 - A064824	18-7688	N/A	N/A	N/A	N/A	N/A ◆
MX 6.2L MPI HORIZON DTS	6.2L	377	V-8	2007	A064825 - A299999	N/A	N/A	N/A	N/A	N/A	N/A ◆
MX 6.2L MPI HORIZON MIE	6.2L	377	V-8	2002-2004	M300000 - M398394	18-7688	18-7701	18-7700	N/A	N/A	N/A ◆
MX 6.2L MPI HORIZON MIE	6.2L	377	V-8	2004-2007	M398395 - A064825	18-7688	18-7701	18-7700	N/A	N/A	N/A ◆
MX 6.2L MPI HORIZON MIE	6.2L	377	V-8	2007-2010	A064825 & UP	N/A	18-7701	18-7700	N/A	N/A	N/A ◆
MX 6.2L MPI HORIZON MIE DTS	6.2L	377	V-8	2005-2007	W390000 - A064824	18-7688	N/A	N/A	N/A	N/A	N/A ◆
MX 6.2L MPI HORIZON MIE DTS	6.2L	377	V-8	2007-2010	A064825 & UP	N/A	N/A	N/A	N/A	N/A	N/A ◆
MX 6.2L MPI MIE	6.2L	377	V-8	2002-2004	M300000 - M398394	18-7688	18-7701	18-7700	N/A	N/A	N/A ◆
MX 6.2L MPI MIE	6.2L	377	V-8	2004-2007	M398395 - A064825	18-7688	18-7701	18-7700	N/A	N/A	N/A ◆
MX 6.2L MPI MIE	6.2L	377	V-8	2007-2010	A064825 & UP	N/A	18-7701	18-7700	N/A	N/A	N/A ◆
MX 6.2L MPI MIE DTS	6.2L	377	V-8	2005-2007	W390000 - A064824	18-7688	N/A	N/A	N/A	N/A	N/A ◆
MX 6.2L MPI MIE DTS	6.2L	377	V-8	2007-2010	A064825 & UP	N/A	N/A	N/A	N/A	N/A	N/A ◆

① BRAVO APPS W/SN W060000, ORDER REGULATOR # 892681 ◆ MAPT SENSOR (TEMP & PRESSURE)

FUEL INJECTION SYSTEM APPLICATION (CONT.)

Model	Liter	CID	# CYL	Year Range	Serial # Range	Injector	IAC Valve	TPS	F/P Regulator Rail-Mounted	F/P Regular Cooler Mounted	MAP Sensor
MX 6.2L MPI SKI	6.2L	377	V-8	2002-2007	M317000 - W689999	18-7688	18-7701	18-7700	N/A	N/A	N/A ♦
MX 6.2L BLACK SCORPION SKI	6.2L	377	V-8	2001-2003	L005601 - M391599	N/A	18-7697	18-7757	N/A	N/A	N/A
MX 6.2L BLACK SCORPION SKI	6.2L	377	V-8	2003-2007	M391750 - W698432	N/A	18-7701	18-7757	N/A	N/A	N/A
454 MAG EFI	7.4L	454	V-8	1994-1996	F115700 - F802349	N/A	18-7632-1	18-7630	N/A	N/A	18-7684
454 MAG EFI SKI	7.4L	454	V-8	1995-1996	F215800 - F820099	N/A	18-7632-1	18-7630	N/A	N/A	18-7684
454 MAG EFI SKI	7.4L	454	V-8	1996-1997	F820099 - K999999	N/A	18-7632-1	18-7630	N/A	N/A	18-7684
454 MAG MPI	7.4L	454	V-8	1996-1997	F802350 - K147349	N/A	18-7632-1	18-7630	N/A	N/A	18-7684
454 MAG MPI	7.4L	454	V-8	1997-1998	K147350 - L085399	N/A	18-7632-1	18-7630	N/A	N/A	18-7684
454 MAG MPI	7.4L	454	V-8	1999-2001	L085400 - M024999	N/A	18-7632-1	18-7630	N/A	N/A	18-7684
454 MAG MPI HORIZON MIE	7.4L	454	V-8	1998	L002200 - L086049	N/A	18-7632-1	18-7630	N/A	N/A	18-7684
454 MAG MPI HORIZON MIE	7.4L	454	V-8	1999-2001	L086050 - L674000	N/A	18-7632-1	18-7630	N/A	N/A	18-7684
7.4L MPI (L29)	7.4L	454	V-8	1998-2001	L010003 - M024330	N/A	18-7697	18-7700	18-7663	N/A	N/A
7.4L MPI MIE	7.4L	454	V-8	1995-1996	F563052 - K147349	N/A	18-7632-1	18-7630	N/A	N/A	18-7684
7.4L MPI MIE	7.4L	454	V-8	1997	K147350 - K999999	N/A	N/A	18-7630	N/A	N/A	18-7684
7.4L MPI MIE (L29)	7.4L	454	V-8	1998-2001	L010003 - L674613	N/A	N/A	18-7700	18-7663	N/A	N/A
7.4LX TBI	7.4L	454	V-8	1996-1997	F820000 - K999999	N.L.A.	18-7632-1	18-7630	N/A	N/A	18-7684
7.4LX MPI	7.4L	454	V-8	1996	F602010 - K147349	N/A	18-7632-1	18-7630	N/A	N/A	18-7684
7.4LX MPI	7.4L	454	V-8	1997	K147350 - K999999	N/A	18-7632-1	18-7630	N/A	N/A	18-7684
496 MAG		496	V-8	2001-2004	M025000 - W059999	N/A	N/A	18-7700	18-7663	N/A	N/A
496 MAG		496	V-8	2004	W060000 - W060573	N/A	N/A	18-7700	18-7663	N/A	N/A
496 MAG		496	V-8	2004-2010	W060574 - & UP	N/A	N/A	18-7700	N/A	N/A	N/A
496 MAG DTS		496	V-8	2001-2004	M025000 - W059999	N/A	N/A	N/A	18-7663	N/A	N/A
496 MAG DTS		496	V-8	2004	W060000 - W060573	N/A	N/A	N/A	18-7663	N/A	N/A
496 MAG HO		496	V-8	2001-2004	M025000 - W059999	N/A	N/A	18-7700	18-7663	N/A	N/A
496 MAG HO		496	V-8	2004	W060000 - W060461	N/A	N/A	18-7700	18-7663	N/A	N/A
496 MAG HO		496	V-8	2004-2010	W060462 - & UP	N/A	N/A	18-7700	N/A	N/A	N/A
496 MAG HO DTS		496	V-8	2001-2004	M025000 - W059999	N/A	N/A	N/A	18-7663	N/A	N/A
496 MAG HO DTS		496	V-8	2004	W060000 - W060461	N/A	N/A	N/A	18-7663	N/A	N/A
496 MAG HO DTS		496	V-8	2004-2010	W060462 - & UP	N/A	N/A	N/A	N/A	N/A	N/A
496 MAG & HO EC		496	V-8	2007-2010	A066166 & UP	N/A	N/A	18-7700	N/A	N/A	N/A
496 MAG & HO DTS EC		496	V-8	2010		N/A	N/A	N/A	N/A	N/A	N/A
8.1L & HO MIE		496	V-8	2001-2004	M026000 - W089999	N/A	N/A	18-7700	18-7663	N/A	N/A
8.1L & HO MIE		496	V-8	2004	W090000 - W389999	N/A	N/A	18-7700	18-7663	N/A	N/A
8.1L & HO MIE		496	V-8	2004-2010	W390000 - & UP	N/A	N/A	18-7700	N/A	N/A	N/A
8.1L & HO MIE DTS		496	V-8	2001-2004	M026000 - W089999	N/A	N/A	N/A	18-7663	N/A	N/A
8.1L & HO MIE DTS		496	V-8	2004	W090000 - W389999	N/A	N/A	N/A	18-7663	N/A	N/A
8.1L & HO MIE EC		496	V-8	2007-2010	W697154 - & UP	N/A	N/A	18-7700	N/A	N/A	N/A
500 EFI	8.2L	502	V-8	1999-2005	L001477 - M907127	N/A	18-7632-1	N/A	N/A	N/A	18-7684
502 MAG MPI	8.2L	502	V-8	1993-1996	D840650 - K147349	N/A	18-7632-1	18-7630	N/A	N/A	18-7684
502 MAG MPI	8.2L	502	V-8	1997-1998	K147350 - L085432	N/A	18-7632-1	18-7630	N/A	N/A	18-7684
502 MAG MPI	8.2L	502	V-8	1999-2001	L085432 - M024999	N/A	18-7632-1	18-7630	N/A	N/A	18-7684
575 Sci	8.2L	502	V-8	2000-2005	L306696 - M950526	N.L.A.	18-7632-1	18-7630	N/A	N/A	N/A
575 Sci	8.2L	502	V-8	2000-2005	L306696 - M950526	N.L.A.	18-7632-1	18-7630	N/A	N/A	N/A
8.2L MAG	8.2L	502	V-8	2010	A350340 & UP	N/A	N/A	18-7700	N/A	N/A	N/A
8.2L MIE	8.2L	502	V-8	2010	A350340 & UP	N/A	N/A	18-7700	N/A	N/A	N/A
8.2L MPI MIE	8.2L	502	V-8	1996	F819620 - K147349	N/A	18-7632-1	18-7630	N/A	N/A	18-7684
8.2L MPI MIE	8.2L	502	V-8	1997-1998	K127350 - L086012	N/A	18-7632-1	18-7630	N/A	N/A	18-7684
8.2L MPI MIE	8.2L	502	V-8	1999-2001	L086013 - L674200	N/A	18-7632-1	18-7630	N/A	N/A	18-7684

① BRAVO APPS W/SN W060000, ORDER REGULATOR # 892681

♦ MAPT SENSOR (TEMP & PRESSURE)



ALL SIERRA CARBURETORS INCLUDE BASE GASKET

- Precision remanufactured to meet or exceed OEM specifications
- Re-calibrated and re-engineered to maximize fuel efficiency and performance
- All carburetors are flow tested throughout the entire throttle range
- Fuel mixture and idle settings are pre-set to ensure that only minor idle and choke adjustments are necessary during installation
- All bases are resurfaced and throttle shaft bushings replaced



18-7370N
CARBURETOR
 Replaces: 3310-860070A2,
 3310-806077A2, 3310-806078A2,
 1389-9562A1, 1389-9350A2,
 1389-8490A2, 1389-815396A2
 For: MCM 120/2.5L & 140/3.0L



18-7373N
MERCARB 2V CARBURETOR
 Replaces: 3310-864941A01
 2002-2004 4.3L engines
 (s/n OM615000-OW300012
 Uses Carb Kit **18-7098-1**



18-7375N
CARBURETOR
 Replaces: 3310-864942A01,
 3310-861448A1
 For: 1998-2004 MCM 5.0L



18-7376N
CARBURETOR
 Replaces: 3310-864943A01,
 3310-861245A1
 For: 1998 and newer 5.7L applications



18-7615N
Q-JET CARBURETOR
 Replaces: 1347-816373A4,
 1347-804624R1,
 1347-804624R02
 Uses Carb Kit **18-7095**



18-7639
CARBURETOR
 Replaces: 3310-864943A01,
 861245A1
 Mercarb-5.7L 2V 1998 and newer 5.7L
 (OL010337-OW300754) & 5.7L MIE
 (OL002003-OW090899)
(Remanufactured)
 Uses Carb Kit **18-7098-1** & Gasket **18-0994**



18-7640
CARBURETOR
 Universal Q-jet with electric choke
(Remanufactured)
 Uses Carb Kit **18-7095** & Gasket **18-0994**



18-7603-1
CARBURETOR
 2 Barrel - Rochester
 Replaces: 1347-818622,
 1376-5659A1, 1347-818622 1,
 1347-818622R02
(Remanufactured)
 Uses Carb Kit **18-7075** & Gaskets **18-0994**
 (left) & **18-0434** (right)



18-7604-1
CARBURETOR
 4 Barrel - Rochester
 Replaces: 3304-9354A2,
 1347-804623R02, 1347-804623R1
(Remanufactured)
 Uses Carb Kit **18-7095** & Gasket **18-2648**



18-7605-1
CARBURETOR
 4 Barrel - Rochester
 Replaces: 1347-9661A3,
 1347-804623A1, 1347-804623R02
(Remanufactured)
 Uses Carb Kit **18-7095** & Gasket **18-2648**



18-7608-1
CARBURETOR
 2 Barrel - Rochester
 Replaces: 1347-818620,
 1347-818620 1, 1347-818620R02
(Remanufactured)
 Uses Carb Kit **18-7070** & Gasket **18-0356**



18-7609-1
CARBURETOR
 2 Barrel - Rochester
 Replaces: 1347-818619,
 1347-818619 1, 1347-818619 1R
(Remanufactured)
 Uses Carb Kit **18-7070** & Gasket **18-0356**



18-7610-1
CARBURETOR
 2 Barrel - Rochester
 Replaces: 1347-818621,
 1347-818621 1, 1347-818621 1R02
(Remanufactured)
 Uses Carb Kit **18-7070** & Gasket **18-0396**



18-7611-2
CARBURETOR
 2 Barrel - Rochester
 Replaces: 3310-807312A1, 3310-807312R02
(Remanufactured)
 Uses Carb Kit **18-7097** & Gasket **18-0994**

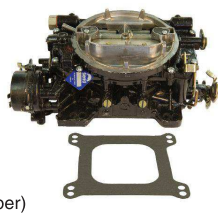

18-7613-1
CARBURETOR
 4 Barrel - Carter (Weber)
 Replaces: 3310-806969A1, 3310-806969R01
(Remanufactured)
 Uses Gasket **18-0467**



18-7615-1
CARBURETOR
 4 Barrel - Rochester
 Replaces: 1347-816373A4,
 1347-804624R1, 1347-804624R02
(Remanufactured)
 Uses Carb Kit **18-7095** & Gasket **18-2548**

ALL SIERRA CARBURETORS INCLUDE BASE GASKET

 <p>18-7616-1 CARBURETOR 4 Barrel - Rochester Replaces: 1347-8288A1, 1347-804626R02 (Remanufactured) Uses Carb Kit 18-7072 & Gasket 18-2848</p>	 <p>18-7617-1 CARBURETOR 4 Barrel - Rochester Replaces: 1347-9863A3, 1347-804624R1, 1347-804625R02 (Remanufactured) Uses Carb Kit 18-7095 & Gasket 18-2848</p>	 <p>18-7618-1 CARBURETOR 4 Barrel - Rochester Replaces: 1347-8289A1, 1347-804624R1, 1347-804624R02 (Remanufactured) Uses Carb Kit 18-7095 & Gasket 18-2848</p>
 <p>18-7619-1 CARBURETOR 4 Barrel - Rochester Replaces: 1347-9142A2, 1347-8460A3 (Remanufactured) Uses Carb Kit 18-7095 & Gasket 18-0462</p>	 <p>18-79994N CARBURETOR Replaces: 3310-866142A04, 3310-866142A03 Fits: TKS-5.0L</p>	 <p>18-79995N CARBURETOR Replaces: 3310-866143A03 Fits: TKS-5.7L</p>

CARBURETOR APPLICATION

Model	CID/Cyl	Year Range	Beginning Serial #	Ending Serial #	Original Carb Part Number	Carb Code/Model	Carb Repair Kit	Replacement O.E. Carb No.	Float	Sierra Carb #
90	96/L4	1970-1971	2851424	3225967	1351- 4263A 1	7040082 R2/2GC	18-7746	1347-818619R02	18-7200	18-7609-1
90	96/L4	1972	3225868	3226957	1351- 4263A 1	7036543 R2/2GC	18-7746	1347-818619R02	18-7200	18-7609-1
110	153/L4	1963-1966	1357370	2044033	1336-2076	R2/2GC	—	—	—	18-7609-1
120	153/L4	1972-1973	3377341	3770649	1351-4263A3	7043182 R2/2GC	18-7746	1347-818619R02	18-7200	18-7609-1
120	153/L4	1974-1975	3770650	4469865	1351-5202A1	7044182 R2/2GC	18-7746	1347-818619R02	18-7200	18-7609-1
120	153/L4	1976-1978	4469866	5192048	1351-6065A2	7044182 R2/2GC	18-7746	1347-818619R02	18-7200	18-7609-1
120	153/L4	1979-1982	5192049	6229717	1351-7354A1	17059054 R2/2GC	18-7746	1347-818619R02	18-7200	18-7609-1
120	153/L4	1983	6229718	6663797	1351- 8480A 2	17081060 R2/2GC	18-7746	1347-818621R02	18-7200	18-7610-1
120	153/L4	1984	6663798	6853913	1389- 8490A 2	M2/MERCarb	18-7097	3310-860070A 2	18-7202	—
120	153/L4	1985	6853914	A492055	1389- 9350A 2	M2/MERCarb	18-7097	3310-860070A 2	18-7202	—
120	153/L4	1986	A492056	B531853	1389- 9562A 1	M2/MERCarb	18-7098-1	3310-860070A 2	18-7202	—
2.5L	153/L4	1983-1989	B531854	C853255	3310-806077A 2	M2/MERCarb	18-7098-1	3310-860070A 2	18-7202	—
140	181/L4	1968-1969	2508261	2816416	1351- 3635A 1	7036646 R/2GC	18-7746	—	18-7200	—
140	181/L4	1970	2816417	2911439	1351- 4032A 1	7040080 R/2GC	18-7746	1347-818620R02	18-7200	18-7608-1
140	181/L4	1970-1973	2911440	3771644	1351-4293A1	7040084 R/2GC	18-7746	1347-818620R02	18-7200	18-7608-1
140	181/L4	1974-1978	3771645	5157668	1351-5203A1	7043184 R/2GC	18-7746	1347-818620R02	18-7200	18-7608-1
140	181/L4	1979-1982	5157669	6229717	1351-7355A1	17059052 R/2GC	18-7746	1347-818620R02	18-7200	18-7608-1
140	181/L4	1983	6229718	6671328	1351- 8480A 2	17081060 R/2GC	18-7746	1347-818621R02	18-7200	—
140	181/L4	1984	6671329	6852269	1389- 8490A 2	M2/MERCarb	18-7097	3310-860070A 2	18-7202	—
140	181/L4	1985	6852270	A484072	1389- 9350A 2	M2/MERCarb	18-7097	3310-860070A 2	18-7202	—
140	181/L4	1986	A484073	B450800	1389- 9562A 1	M2/MERCarb	18-7098-1	3310-860070A 2	18-7202	—
140/3.0L	181/L4	1983-1989	6229718	C856556	1351-8480A2	R2/2GC	—	1348-818621 1	—	18-7610-1
3.0L	181/L4	1987-1989	B450801	C856556	3310-806077A 2	M2/MERCarb	18-7098-1	3310-860070A 2	18-7202	—
3.0L	181/L4	1990	C856559	D447414	1389-815396A 2	M2/MERCarb	18-7098-1	3310-860070A 2	18-7202	—
3.0L	181/L4	1991-1993	D447415	D836075	1389-806077A 2	M2/MERCarb	18-7098-1	3310-860070A 2	18-7202	—
3.0L	181/L4	1993-1994	D836076	F603999	1389-806078A 1	M2/MERCarb	18-7098-1	3310-860070A 2	18-7202	—
3.0L	181/L4	1998-2002	L010042	M385672	3310-807504A 1	M2/MERCarb	18-7098-1	3310-8M0045397	18-7202	—
3.0L	181/L4	2003-2004	M385673	W301999	3310-864940A01	M2/MERCarb	18-7098-1	3310-8M0045397	18-7202	—
3.0L	181/L4	1999-2004	L382122	W301999	3310-864940A01	M2/MERCarb	18-7098-1	865959A01	18-7202 □	—

- | | | |
|-------------------|-------------------------------------|---------------------------------|
| ① Automatic Choke | ⑥ On-Line | ① Use with in-line transmission |
| ② Black | ⑦ Rear (Blue) | ② Use with V-drive transmission |
| ③ Blue | ⑧ Spacer Mounted | ③ V-drive |
| ④ Electric Choke | ⑨ Use if original carb is MERCarb | ④ Wedge mounted |
| ⑤ Front (Blue) | ⑩ Use if original carb is Rochester | ⑤ TKS Retrofit Kit |

CARBURETOR APPLICATION

Model	CID/Cyl	Year Range	Beginning Serial #	Ending Serial #	Original Carb Part Number	Carb Code/Model	Carb Repair Kit	Replacement O.E. Carb No.	Float	Sierra Carb #
3.0L	181/L4	2004-2010	W302000	& UP	3310-866140A02	M2/MERCarb	18-7098-1	3310-866140A02	18-7202	—
3.0LX	181/L4	1990-1997	C856559	K999999	1389-815397A 2	M2/MERCarb	18-7098-1	3310-8M0045397	18-7202	—
3.0LX	181/L4	1990-1997	C856559	K999999	3310-805924A 2	M2/MERCarb	18-7098-1	3310-8M0045397	18-7202	—
165 (4 CYL)	224/L4	1987	B434941	B774251	1389- 9564A 1	M2/MERCarb	18-7098-1	3310-860071A 2	18-7202	—
170	224/L4	1985-1989	6916779	B434940	1389- 9564A 1	M2/MERCarb	18-7098-1	3310-860071A 2	18-7202	—
180	224/L4	1987	B436391	B775248	1347- 9142A 2	17083522 R4/4ME	18-7077	—	18-7201	—
190 (4 CYL)	224/L4	1985-1986	6916779	B436390	1347- 9142A 2	17083522 R4/4ME	18-7077	—	18-7201	—
3.7L	224/L4	1988-1989	B774252	& UP	1389- 9564A 1	M2/MERCarb	18-7098-1	3310-860071A 2	18-7202	—
3.7LX	224/L4	1988-1989	B775249	& UP	1347- 9142A 2	17083522 R4/4ME	18-7077	—	18-7201	—
470	224/L4	1976-1984	4208730	6916778	1376- 5990A 1	17057132 R2/2GC	18-7076	3310-860071A 4	18-7202 Ⓢ	—
470	224/L4	1983-1984	6218037	6916778	1389- 8489A 5	M2/MERCarb	18-7097	3310-860071A 2	18-7202 Ⓢ	—
485	224/L4	1980-1982	5685394	6218036	1376- 5990A 1	17057132 R2/2GC	18-7076	3310-860071A 4	18-7202	—
488	224/L4	1983-1984	6170297	6916778	1347- 8460A 3	17081299 R4/4ME	18-7077	—	18-7201	18-7619-1
150	230/L6	1964-1966	1830152	2048046	1338- 2633	8025188 R2/2GC	18-7746	—	18-7200	—
160	250/L6	1967-1968	2048022	2492038	1338- 2991	7026088 R2/2GC	18-7746	—	18-7200	—
160	250/L6	1969	2492036	277031	1351- 3635A 1	7036646 R/2GC	18-7746	—	18-7200	—
165 (6 CYL)	250/L6	1970-1972	3774865	3354791	1351-4282A1	7043183 R2/2GC	18-7746	1347-818620R02	18-7200	18-7608-1
165 (6 Cyl)	250/L6	1979-1981	5178959	5813433	1351-7356A1	17059050 R2/2GC	18-7746	1347-818620R02	18-7200	18-7608-1
165 (6 Cyl)	L6	1972-1973	3354702	3774864	1351-4871A1	R2/2GC	—	1347-818620 1	—	18-7608-1
180/190 3.7L,					—	R4/4ME	—	1347-8460	—	18-7619-1
L4 Engine	—	1985-1989	6916779	Later	1347-9142A2	R4/4ME	—	—	—	18-7619-1
200 (6 CYL)	292/L6	1969	2453769	2494935	1347- 3237A 4	7037082 R4/4MV	18-7077	—	18-7201	—
185 (4bbl)	229/V-6	1993-1994	6330183	6919655	3300- 8886A 2	17083515 R4/4ME	18-7077	—	18-7201	—
175	262/V-6	1987	B527955	B773242	3304- 9565A 1	M2/MERCarb	18-7098-1	3310-807764A 1	18-7202	—
185	262/V-6	1985-1986	A331455	B527954	3304- 9353A 2	M2/MERCarb	18-7097	3310-807764A 1	18-7202	—
205	262/V-6	1985-1987	A331455	B775129	3304-9354A2	17084516 R4/4MV	18-7077	—	18-7201	18-7605-1
4.3L	262/V-6	1988-1992	B773243	D714106	3304- 9565A 1	M2/MERCarb	18-7098-1	3310-807764A 1	18-7202	—
4.3L	262/V-6	1992-1993	D714107	F000877	3304- 9565A 1	M2/MERCarb	18-7098-1	3310-807764A 1	18-7202	—
4.3L	262/V-6	1993-1995	F000878	F601126	3310-806972A 1	M2/MERCarb	18-7098-1	3310-807764A 1	18-7202	—
4.3L	262/V-6	1996-2002	F601127	M614999	3310-807764A 1	M2/MERCarb	18-7098-1	3310-807764A 1	18-7202	—
4.3L	262/V-6	2002-2004	M615000	W300012	3310-864941A01	M2/MERCarb	18-7098-1	3310-864941A01	18-7202	—
4.3L	262/V-6	2000-2004	L619000	W300012	3310-864941A01	M2/MERCarb	18-7098-1	865960A02	18-7202 Ⓢ	—
4.3L	262/V-6	2004- 2010	W300013	& UP	3310-866141A02	M2/MERCarb	18-7098-1	3310-866141A02	18-7202	—
4.3LH	262/V-6	1998-2002	L010044	M614999	3310-807826A 1	9666 WEBER	18-7749	—	—	—
4.3LX	262/V-6	1988-1991	B775130	D714369	3304- 9354A 2	17084516 R4/4MV	18-7077	1347-804623R02	18-7201	18-7605-1
4.3LX	262/V-6	1992-1996	D714370	F802999	3310-818660A 1	9600 WEBER	18-7749	—	—	—
4.3XH	262/V-6	1996-1997	F803114	K999999	3310-807826A 1	9666 WEBER	18-7749	—	—	—
215 MCM/MIE (FORD)	302/V-8	1970-1972	2781153	3385720	1356- 4066	C9FF9510E H4/4160	18-7096	1356-804628R02	18-7206	—
225 MCM/MIE (FORD)	302/V-8	1973-1974	3385721	4166999	1356- 5155	D2JL9510C H4/4160	18-7096	1356-804628R02	18-7206	—
888	302/V-8	1971-1977	3108723	4887829	1376-5659A1	7044185 R2/2GC	18-7075	1376-818622R02	18-7202 Ⓢ	18-7603-1
888	302/V-8	1971-1977	3108723	4887829	1356- 4642	D1JJ95108 H2/2300	18-7081	—	—	—
198 MIE	305/V-8	1977	4776402	4931099	1376- 6491A 1	17057139 R2/2GC	18-7075	3310-861080A 1	18-7202	—
200	305/V-8	1985-1986	6899058	A482026	1389- 8488A 2	M2/MERCarb	18-7097	3310-861080A 1	18-7202	—
200	305/V-8	1985-1987	A482027	B525981	1389- 9563A 1	M2/MERCarb	18-7098-1	3310-861080A 1	18-7202	—
200	305/V-8	1987	B525982	B774444	1389- 9670A 2	M2/MERCarb	18-7098-1	3310-807312A1	18-7202	—
228	305/V-8	1977-1978	4765100	5069430	1347-6427A1	17057282 R4/4MV	18-7077	9661A 3	18-7201	18-7605-1
228	305/V-8	1978-1981	5069431	6021783	1347-7361A1	17059292 R4/4MV	18-7077	9661A 3	18-7201	18-7605-1
228	305/V-8	1982	6021784	6218461	1347-8296A4	17080565 R4/4MV	18-7077	9661A 3	18-7201	18-7605-1
228	305/V-8	1982-1984	6218462	6899268	1347- 9661A 3	17080565 R4/4MV	18-7077	9661A 3	18-7201	18-7605-1
228 MIE	305/V-8	1977-1978	4765100	5069430	1347-6438A1	17057283 R4/4MV	18-7077	9661A 3	18-7201	18-7605-1
228 MIE	305/V-8	1978-1982	5069431	6040745	1347-7364A1	17059291 R4/4MV	18-7077	9661A 3	18-7201	18-7605-1
228 TR	305/V-8	1977-1978	4765100	5069430	1347- 6438A 1	17057283 R4/4MV	18-7077	9661A 3	18-7201	18-7605-1

- Ⓢ Automatic Choke
- Ⓣ Black
- Ⓤ Blue
- Ⓥ Electric Choke
- Ⓦ Front (Blue)

- Ⓧ On-Line
- Ⓨ Rear (Blue)
- Ⓩ Spacer Mounted
- ⓐ Use if original carb is MERCarb
- ⓑ Use if original carb is Rochester

- ⓓ Use with in-line transmission
- ⓔ Use with V-drive transmission
- ⓕ V-drive
- ⓖ Wedge mounted
- ⓗ TKS Retrofit Kit

CARBURETOR APPLICATION

Model	CID/Cyl	Year Range	Beginning Serial #	Ending Serial #	Original Carb Part Number	Carb Code/Model	Carb Repair Kit	Replacement O.E. Carb No.	Float	Sierra Carb #
230	305/V-8	1985-1987	6899269	B773739	1347- 9661A 3	17080565 R4/4MV	18-7077	9661A 3	18-7201	18-7605-1
230 MIE	305/V-8	1982-1987	6040746	B788151	1347-8290A1	17080564 R4/4MV	18-7077	9661A 3	18-7201	18-7605-1
223/230/5.0LX	V-8	1983-1995	6218462	F600999	1347-9661A3	R4/4MV	—	1347-9661A3	—	18-7605-1
5.0L	305/V-8	1988-1995	B774445	F600999	1389- 9670A 2	M2/MERCARB	18-7098-1	3310-807312A1	18-7202	—
5.0L (GEN +)	305/V-8	1998-2002	L015751	M599999	3310-861448A 1	M2/MERCARB	18-7098-1	3310-864942A01	18-7202	—
5.0L (GEN +)	305/V-8	2002-2004	M600000	W300009	3310-864942A01	M2/MERCARB	18-7098-1	3310-864942A01	18-7202	—
5.0L (GEN +)	305/V-8	2000-2004	L619000	W300009	3310-864942A01	M2/MERCARB	18-7098-1	865961A02	18-7202 ⑤	—
5.0L (GEN +)	305/V-8	2004-2010	W300010	& UP	3310-866142A03	M2/MERCARB	18-7098-1	3310-866142A04	18-7202	—
5.0LX	305/V-8	1988-1995	B773740	F600999	1347- 9661A 3	17080565 R4/4MV	18-7077	9661A 3	18-7201	18-7605-1
898/200/5.0L	V-8	1987-95	B525982	F600999	1389-9670A2	M2/MERCARB	—	3310-807312A1	—	18-7611-1
898	305/V-8	1977	4762210	6021383	1376- 6491A 1	17057139 R2/2GC	18-7075	3310-861080A 1	18-7202	—
898	305/V-8	1982	6021384	6218461	1376- 8295A 3	17080350 R2/2GC	18-7075	3310-861080A 1	18-7202	—
898	305/V-8	1983-1984	6218462	6899057	1389- 8488A 2	M2/MERCARB	18-7097	3310-861080A 1	18-7202	—
225 MCM/MIE (GM)	327/V-8	1963-1969	1539620	2694014	1347- 3237A 3 ④	7037082 R4/4MV	—	1347-804624R02	—	18-7615N
250	350/V-8	1977	4768000	4908849	1347- 3353 ①	7037082 R4/4MV	—	1347-804624R02	—	18-7615N
250	350/V-8	1977	4768000	4908849	1347- 3237A 3 ④	7037082 R4/4MV	—	1347-804624R02	—	18-7615N
255	350/V-8	1975-1976	4175550	4767999	1347- 5732A 1	7044291 R4/4MV	18-7077	1347-804624R02	18-7201	18-7615N
255 MIE (GM)	350/V-8	1975-1978	4175550	4924564	1347- 5732A 1	7044291 R4/4MV	18-7077	1347-804624R02	18-7201	18-7615N
255 MIE (GM)	350/V-8	1978	4924565	5195908	1347-7062A1	17057292 R4/4MV	18-7077	1347-804624R02	18-7201	18-7615N
255 MIE (GM)	350/V-8	1979-1980	5195909	5907057	1347-7365A1	17059289 R4/4MV	18-7077	1347-804624R02	18-7201	18-7615N
260 MIE	V-8	1980-1986	5907058	B522505	1347-8289A1	R4/4MV	—	1347-8289A1	—	18-7618-1
260	350/V-8	1978	4908850	5060805	1347- 6492A 1	17057298 R4/4MV	18-7077	1347-804624R02	18-7201	18-7615N
260	350/V-8	1976-1982	5060806	6024393	1347- 7362A 1	17059288 R4/4MV	18-7077	1347-804624R02	18-7201	18-7615N
260	350/V-8	1982-1987	6024393	B525981	1347- 8292A 4	17080561 R4/4MV	18-7077	1347-804624R02	18-7201	18-7615N
260	350/V-8	1987	B525982	B773304	1347- 9662A 1	17080561 R4/4MV	18-7077	1347-804624R02	18-7201	18-7615N
260 MIE	350/V-8	1981-1987	5907058	B522505	1347- 8289A 1	17080562 R4/4MV	18-7077	1347-804624R02	18-7201	18-7615N
260 MIE	350/V-8	1987	B522506	B788151	1347- 9662A 1	17080561 R4/4MV	18-7077	1347-804624R02	18-7201	18-7615N
260/5.7MIE	V-8	1987-1993	B522506	F024999	1347-966A4	R4/4MV	—	1347-816373A4	—	18-7615N
260/5.7L ALPHA	V-8	1987-1993	B525982	F000454	1347-9662A4	R4/4MV	—	1347-816373A4	—	18-7615N
270 MCM/MIE	350/V-8	1969-1972	2851074	3385720	1347- 4180A 1	7029285 R4/4MV	18-7077	—	18-7201	—
280 TRS	350/V-8	1975	4176250	4176468	1347- 4179A 2	7040283 R4/4MV	18-7077	—	18-7201	—
280 TRS	350/V-8	1975-1976	4176469	4770199	1347- 5981A 1	7044290 R4/4MV	18-7077	—	18-7201	—
300 MR/TRS	350/V-8	1985-1986	6668677	B430367	1347- 7498A 7	17059280 R4/4MV	18-7077	—	18-7201	18-7615N
350 MAG ALPHA	350/V-8	1986-1991	A635178	D617327	1347- 8289A 1	17080562 R4/4MV	18-7077	1347-804624R02	18-7201	18-7615N
350 MAG ALPHA	350/V-8	1992-1995	D617328	F600999	3310-806970A 1	9770SA WEBER	18-7749	3310-807262A 1	—	—
350 MAG ALPHA	350/V-8	1996-1997	F601000	K999999	3310-807262A 2	9781 WEBER	18-7748	—	—	—
350 MAG SKI	350/V-8	1991-1996	D505450	K040399	3310-806970A 1 ⑩	9770SA WEBER	18-7749	—	— ①	—
350 MAG SKI	350/V-8	1991-1997	D505450	K999999	3310-807262A 2 ⑩	9781 WEBER	18-7748	—	— ①	—
350 MAG SKI	350/V-8	1997	K040400	K999999	3310-860371A 1 ⑩	9781SB WEBER	18-7748	—	— ②	—
5.7L (2BBL)	350/V-8	1996-1997	F601000	K999999	3310-807312A1	M2/MERCARB	18-7098-1	3310-807312A1	18-7202	18-7611-2
5.7L (GEN +) (2bbl)	350/V-8	1998-2002	L010037	M599999	3310-861245A 1	M2/MERCARB	18-7098-1	3310-864943A01	18-7202	18-7639
5.7L (GEN +) (2bbl)	350/V-8	2002-2004	M600000	W300754	3310-864943A01	M2/MERCARB	18-7098-1	3310-864943A01	18-7202	18-7639
5.7L (GEN +) (2bbl)	350/V-8	2000-2004	L015751	W300754	3310-864943A01	M2/MERCARB	18-7098-1	865962A02	18-7202 ⑤	—
5.7L (Gen II)	V-8	1998-2004	L010037	W300754	3310-864943101	M2/MERCARB	—	3310-864943101	—	18-7639
5.7L (GEN +) (2bbl)	350/V-8	2004-2010	W300755	& UP	3310-866143A03	M2/MERCARB	18-7098-1	3310-866143A03	18-7202	—
5.7L ALPHA	350/V-8	1988-1993	B773305	F000454	1347- 9662A 4	17080561 R4/4MV	18-7077	1347-804624R02	18-7201	18-7615N
5.7L ALPHA	350/V-8	1993-1994	F000455	F273497	3310-805484A 1	9661 WEBER	18-7749	—	—	—
5.7L ALPHA	350/V-8	1993-1994	F000455	F273497	3310-806761A 1	9665S WEBER	18-7748	—	—	—
5.7L ALPHA	350/V-8	1994-1995	F273498	F600999	3310-806761A 3	9665S WEBER	18-7748	3310-806761A 3	—	—
5.7L BRAVO	350/V-8	1988-1991	B773305	D617327	1347- 9662A 4	17080561 R4/4MV	18-7077	1347-804624R02	18-7201	18-7615N
(W/O HIGH RISE INTAKE)										
5.7L BRAVO	350/V-8	1988-1991	B773305	D617327	1347- 8289A 1	17080562 R4/4MV	18-7077	1347-804624R02	18-7201	18-7615N
(W/HIGH RISE INTAKE)										

- ① Automatic Choke
- ② Black
- ③ Blue
- ④ Electric Choke
- ⑤ Front (Blue)

- ⑥ On-Line
- ⑦ Rear (Blue)
- ⑧ Spacer Mounted
- ⑨ Use if original carb is MERCARB
- ⑩ Use if original carb is Rochester

- ① Use with in-line transmission
- ② Use with V-drive transmission
- ③ V-drive
- ④ Wedge mounted
- ⑤ TKS Retrofit Kit

CARBURETOR APPLICATION

Model	CID/Cyl	Year Range	Beginning Serial #	Ending Serial #	Original Carb Part Number	Carb Code/Model	Carb Repair Kit	Replacement O.E. Carb No.	Float	Sierra Carb #
5.7L BRAVO	V-8	1987-1991	OB525982	OD617327	1347-9662A4	R4/4MV	—	1347-816373A4	—	18-7615N
W/O HIGH RISE INTAKE										
5.7L BRAVO	V-8	1987-1991	OB525982	OD617327	1347-8289A1	R4/4MV	—	1347-8289A1	—	18-7618-1
W/HIGH RISE INTAKE										
5.7L BRAVO	350/V-8	1992-1995	D617328	F600999	3310-806970A 1	9770SA WEBER	18-7749	3310-807262A 1	—	—
5.7L MIE	350/V-8	1988-1992	B768152	D715493	1347- 9662A 4	17080561 R4/4MV	18-7077	1347-804624R02	18-7201	18-7615N
5.7L MIE	350/V-8	1992-1994	D715494	F349999	3310-806761A 2 □	9665S WEBER	18-7748	3310-806761A 2	—	—
5.7L MIE	350/V-8	1995	F349300	F622099	3310-806761A 3	9665S WEBER	18-7748	3310-806761A 3	—	—
5.7L MIE (2bbl)	350/V-8	1998-2002	L002003	M316999	3310-861245A 1	M2/MERCarb	18-7098-1	3310-864943A01	18-7202	18-7639
5.7L MIE (2bbl)	350/V-8	2002-2004	M317000	W090899	3310-864943A01	M2/MERCarb	18-7098-1	3310-864943A01	18-7202	18-7639
5.7L MIE (2bbl)	350/V-8	2000-2004	L390600	W090899	3310-864943A01	M2/MERCarb	18-7098-1	865962A02	18-7202 ⑤	—
5.7L MIE (2bbl)	350/V-8	2004-2010	W090900	& UP	3310-866143A03	M2/MERCarb	18-7098-1	3310-866143A03	18-7202	—
5.7L SKI	350/V-8	1985-1987	A338553	B514626	1347- 9415T	17085013 R4/4MV	18-7077	9415T	18-7201	—
5.7L SKI	V-8	1985-1993	A338533	F025099	1347-9415T	R4/4MV	—	1347-9415T	—	18-7615N
5.7L SKI	350/V-8	1987-1995	F450000	F775199	3310-805484A 1	9661 WEBER	18-7749	3310-806761A 3	—	—
5.7L SKI (2bbl)	350/V-8	1996-1997	F775200	K999999	3310-807312A1	M2/MERCarb	18-7098-1	3310-807312A1	18-7202	18-7611-2
5.7L SKI (GEN +) (2bbl)	350/V-8	1998-2002	L002005	M316999	3310-861245A 1	M2/MERCarb	18-7098-1	3310-864943A01	—	18-7639
5.7L SKI (GEN +) (2bbl)	350/V-8	2002-2004	M317000	W090899	3310-864943A01	M2/MERCarb	18-7098-1	3310-864943A01	—	18-7639
5.7L SKI (GEN +) (2bbl)	350/V-8	2000-2004	L390600	W090899	3310-864943A01	M2/MERCarb	18-7098-1	865962A02	18-7202 ⑤	18-7618-1
5.7L SKI (GEN +) (2bbl)	350/V-8	2004-2010	W090900	& UP	3310-866143A03	M2/MERCarb	18-7098-1	3310-866143A03	18-7202	—
5.7LX (4bbl)	350/V-8	1996-1997	F601000	K999999	3310-807262A 2	9761 WEBER	18-7748	—	—	—
233 MCM & MCI (FORD)	351/V-8	1975-1977	4173000	4465029	1376- 5744 1	7044187 R2/2GC	18-7075	1347-818622R02	—	18-7603-1
233 MCM & MCI (FORD)	351/V-8	1975-1977	4465030	4902304	1376- 6152A 1	17056197 R2/2GC	18-7075	1347-818622R02	—	18-7603-1
325 MCM/MIE	427/V-8	1969-1970	2278747	3042730	1347- 3342 □	7027080 R4/4MV	18-7077	—	18-7201	—
325 MCM/MIE	427/V-8	1971-1972	3042731	3780449	1347- 4533A 1 □	7041831 R4/4MV	18-7077	—	18-7201	—
325 MCM/MIE	427/V-8	1969-1972	2278747	3780449	1347- 3689A 1 □	7029280 R4/4MV	18-7077	—	18-7201	—
330 MCM	427/V-8	1977-1978	4623115	5027230	1347-6493A1	17057287 R4/4MV	18-7077	1347-804626R02	18-7201	18-7616-1
330 MCM	427/V-8	1977-1981	5027231	6083144	1347-7363A1	17059290 R4/4MV	18-7077	1347-804626R02	18-7201	18-7616-1
330 MCM	427/V-8	1982-1987	6083145	B816540	1347-8291A3	17080563 R4/4MV	18-7077	1347-804626R02	18-7201	18-7616-1
330 MIE	427/V-8	1977-1978	4623115	5226384	1347-6493A1	17057287 R4/4MV	18-7077	1347-804626R02	18-7201	18-7616-1
330 MIE	427/V-8	1979-1980	5226385	5889913	1347-7366A1	17059287 R4/4MV	18-7077	1347-804626R02	18-7201	18-7616-1
340 MIE	454/V-8	1981-1987	5889914	D788365	1347-8288A1	17080560 R4/4MV	18-7077	1347-804626R02	18-7201	18-7616-1
370	454/V-8	1978-1987	4179554	B714586	1347- 7498A 2	17059280 R4/4MV	18-7077	1347-804625R02	18-7201	—
400	454/V-8	1980-1986	4179554	B457644	1347- 7498A 2	17059280 R4/4MV	18-7077	1347-804625R02	18-7201	—
420	454/V-8	1987-1989	A398941	B622418	13549A 4	H4	18-7751	—	—	—
425	454/V-8	1990-1993	B622419	D937011	13549A 4	H4	18-7751	—	—	—
440	454/V-8	1983-1986	4179554	B485220	1393- 8862A 1	H4	18-7751	—	—	—
450	454/V-8	1995-1996	F347100	F347277	13549A14	H4	18-7751	—	—	—
454 MAG ALPHA	454/V-8	1986-1988	A631894	B785148	1347-8291A3	17080563 R4/4MV	18-7077	1347-804626R02	18-7201	18-7616-1
454 MAG BRAVO	454/V-8	1988-1992	B721206	D808068	1347-7498A2	17059280 R4/4MV	18-7077	1347-804625R02	18-7201	18-7617-1
454 MAG BRAVO	454/V-8	1992-1994	D805069	F304999	3310-806755A 1	9779 WEBER	18-7748	—	—	—
454 MAG BRAVO	454/V-8	1995-1997	F305000	K999999	3310-806755A 2	9779 WEBER	18-7748	—	—	—
7.4L BRAVO I/II	454/V-8	1988-1991	B771113	D603117	1347-8291A3	17080563 R4/4MV	18-7077	1347-804626R02	18-7201	18-7616-1
7.4L BRAVO I/II	454/V-8	1992-1994	D603118	F351999	3310-806969A 2	9780 WEBER	18-7748	—	—	—
7.4L BRAVO I/II	454/V-8	1995-1997	F352000	K999999	3310-806969A1	9780 WEBER	18-7748	3310-806969A 1	—	18-7613-1
7.4L BRAVO III	454/V-8	1993-1996	D838819	F800699	3310-806755A 2	9779 WEBER	18-7748	—	—	—
7.4L BRAVO III	454/V-8	1996-1997	F800700	K999999	3310-806969A1	9780 WEBER	18-7748	3310-806969A 1	—	18-7613-1
7.4L MIE	454/V-8	1988-1992	5889914	D715493	1347- 8268A 1	17080560 R4/4MV	18-7077	1347-804626R02	18-7201	18-7616-1
460	482/V-8	1983-1986	4179554	B485220	1393- 8862A 1	H4	18-7751	—	—	—
465	502/V-8	1990-1992	C849992	F213244	—	H4	18-7751	—	—	—
465	502/V-8	1990-1992	C849992	F213244	—	H4	18-7751	—	—	—
500	502/V-8	1994-1995	F213293	F615766	13549A12	H4	18-7751	—	—	—

- ① Automatic Choke
- ② Black
- ③ Blue
- ④ Electric Choke
- ⑤ Front (Blue)

- ⑥ On-Line
- ⑦ Rear (Blue)
- ⑧ Spacer Mounted
- ⑨ Use if original carb is MERCarb
- ⑩ Use if original carb is Rochester

- ① Use with in-line transmission
- ② Use with V-drive transmission
- ③ V-drive
- ④ Wedge mounted
- ⑤ TKS Retrofit Kit

CARBURETOR APPLICATION

Model	CID/Cyl	Year Range	Beginning Serial #	Ending Serial #	Original Carb Part Number	Carb Code/Model	Carb Repair Kit	Replacement O.E. Carb No.	Float	Sierra Carb #
500	502/V-8	1996-1998	F615767	L001772	13549A 15	H4	18-7751	—	—	—
500 (GEN +)	502/V-8	1999	L414639	L601036	13549T21	H4	18-7751	—	—	—
502 MAG	502/V-8	1990-1992	C878221	D824588	1347-814623A 2	17089112 R4/4MV	18-7077	—	18-7201	—
502 MAG	502/V-8	1992-1993	D824589	F114528	3310-806971A 1	9782 WEBER	18-7748	—	—	—
8.2L MIE	502/V-8	1990-1992	C878221	D857199	1347-814623A 2	17089113 R4/4MV	18-7077	—	—	—
8.2L MIE	502/V-8	1990-1992	C878221	D857199	3310-817693A 1	9774 WEBER	18-7748	—	—	—
8.2L MIE	502/V-8	1993-1996	D857200	F819619	3310-806971A 1	9782 WEBER	18-7748	—	—	—
500 BULLDOG	540/V-8	1990-1995	C577254	F348987	13549A10	H4	18-7751	—	—	—
500 BULLDOG	540/V-8	1995-2001	F615762	M050281	13549A23	H4	18-7751	—	—	—

- ① Automatic Choke
- ② Black
- ③ Blue
- ④ Electric Choke
- ⑤ Front (Blue)

- ⑥ On-Line
- ⑦ Rear (Blue)
- ⑧ Spacer Mounted
- ⑨ Use if original carb is MERCarb
- ⑩ Use if original carb is Rochester

- ① Use with in-line transmission
- ② Use with V-drive transmission
- ③ V-drive
- ④ Wedge mounted
- ⑤ TKS Retrofit Kit



18-8114
FUEL LINE HOSE

For fuel pump to carburetor connection. Replaces copper or steel tubing 3/8" X 31" PTFE composite hose with 5/8"-18 male inverted flare straight one end, 5/8"-18 90° one end. SAE J1527 type A1

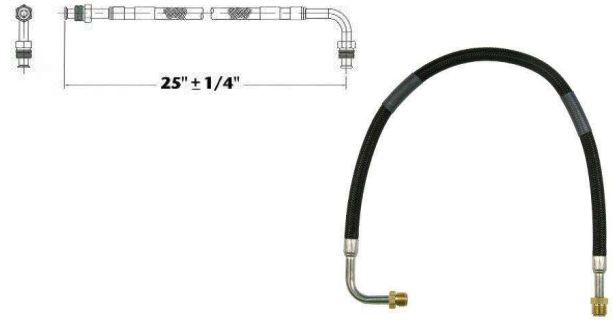

18-8115
FUEL LINE HOSE

For fuel pump to carburetor connection. Replaces copper or steel tubing 3/8" X 25" PTFE composite hose with 5/8"-18 male inverted flare straight one end, 5/8"-18 90° one end. SAE J1527 type A1

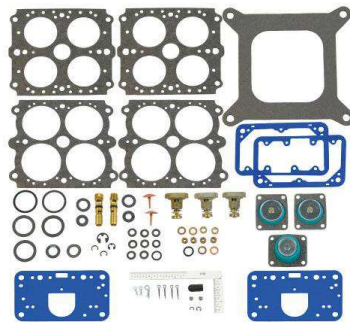

18-7751
CARB KIT

Replaces: 13220
Fits: GM 420 V8 454 (1987-89), GM 425 V8 454 (1990-93), GM 425 (Gen V) V8 454 (1992-93), 440 TRS GM 454 (1983-86), GM 450 V8 454(1995-96), 460 TRS V8 482 (1983-86), GM 465 V8 502 (1990-92), GM 465 (Gen V) V8 502 (1992-94), 500 (Gen+) GM 502 V8 (1999), 500 (Gen V) 502 V8 (1994-98), 500 Bulldog 540 V8 (1990-01)



18-7071
CARB KIT

Replaces: 1397-3458



18-7075
CARB KIT

Replaces: 1397-5830, 1397-7099, 1397-8760, 1397-5831



18-7070
CARB KIT

Replaces: 1397-2072, 1397-7542, 1397-2637, 1397-7543, 1397-8872, 1397-3464



18-7072
CARB KIT
 Replaces: 1397-3306, 1397-4329,
 1397-5635, 1397-6638, 823426A1



18-7076
CARB KIT
 Replaces: 1397-6367, A1



18-7077
CARB KIT
 Replaces: 1397-8952, 823426A1



18-7078
CARB KIT
 Replaces: 1397-2605, 1397-3462, 1397-2133
 Fits: 1337-2604, 1337-2103



18-7080
CARB KIT
 Replaces: 1398-3089
 Fits: 1346-2770



18-7081
CARB KIT
 Replaces: 1396-4656
 Contains adjustable needles and seats



18-7095
CARB KIT
 Replaces: 1397-7539, 1397-7540, 1397-7544,
 1397-8535, 1397-9723



18-7096
CARB KIT
 Replaces: 1396-5238, 1396-5222, 1356-4092
 Fits: 1356-5169, 1356-5155, 1356-4066
 Contains adjustable needles and seats



18-7097
CARB KIT
 Replaces: 3302-9437, 3302-804845
 MerCarb 2 bbl. bottom fill accelerator pump 1983-1986
 MCM 120, 140, 470, 185, 200, 898



18-7098-1
CARB KIT
 Replaces: 3302-804844002,
 3302-804844001, 3302-804844
 MerCarb 2 bbl. side fill accelerator pump
 1986 and UP MCM 4-cyl., V6 & V8



18-7728
CARB KIT



18-7749
CARB KIT
 Replaces: 809065, 835076, 823728



18-7748
CARB KIT
 Replaces: 809064



18-7746
CARB KIT
 Replaces: 823427A1, 1397-8873, 1397-8872,
 1397-7547, 1397-7543, 1397-7542, 1397-3464,
 1397-3459, 1397-2637, 1397-2634, 1397-2631,
 1397-2067
 Repair Kit for 2 BBL Rochester

 <p>18-7200 FLOAT Replaces: 1397-2060 (Alcohol Resistant) Plastic</p>	 <p>18-7201 FLOAT Replaces: 1397-3327, 1397-8546, 1397-8959 (Alcohol Resistant) Brass</p>	 <p>18-7202 FLOAT Replaces: 1397-5837, 3302-9031 (Alcohol Resistant) Brass</p>
 <p>18-36906 CARB FLOAT Replaces: 811536, 811536T Fits: Mercruiser w/ 4 bbl Weber Carb</p>	 <p>18-7666 CHOKE PULL-OFF Replaces: 1397-8582 Rochester 4V carburetors</p>	 <p>18-7664 CHOKE THERMOSTAT Replaces: 809066 Weber 4V Carburetors with electric choke</p>
 <p>18-7665 CHOKE THERMOSTAT Replaces: 70125A1, 70125A02, 70125 Rochester & Mercarb 2V with electric choke</p>	 <p>18-7667 CHOKE THERMOSTAT Replaces: 71464A01, 71464, 72625 Rochester Carburetors with divorced choke</p>	 <p>18-7227 CHOKE THERMOSTAT Replaces: 1396-4148 For: Holley Carburetor</p>

CARBURETOR KIT/FLOAT APPLICATION

Model & Serial #	Mercruiser Carb #	Mfg. Carb #	Carb. Code & Model	Carb Kit ①	Float
MCM 80 ALL	1346-2770	RBS-4394S	C1/RBS	18-7080	—
MCM 90					
3225967 & BELOW	1351-4263A1	7040082	R2/2GC	18-7746	18-7200
3225968 & ABOVE	1351-4263A2	7041369	R2/2GC	18-7746	18-7200
MCM110 ALL	1336-2076	7036543	R2/2GC	18-7070	18-7200
MCM 120/2.5L					
2520424 & BELOW	1336-2076	7036543	R2/2GC	18-7746	18-7200
2520425-3377340	1336-3594A1	7036543	R2/2GC	18-7746	18-7200
3377341-3770649	1351-4263A3	7041369	R2/2GC	18-7746	18-7200
3770650-4469865	1351-5202A1	7043182	R2/2GC	18-7746	18-7200
4469866-5192047	1351-6065A2	7044182	R2/2GC	18-7746	18-7200
5192048-6229717	1351-7354A1	17059054	R2/2GC	18-7746	18-7200
6229718 & ABOVE	1351-8480A2	17081060	R2/2GC	18-7746	18-7200
6229718 & ABOVE	1389-8490A2	N/A	M2/Mercarb	18-7097	18-7202
6229718 & ABOVE	1389-9350A2	N/A	M2/Mercarb	18-7097	18-7202
6229718 & ABOVE	1389-9562A1	N/A	M2/Mercarb	18-7098-1	18-7202
MCM 140 /3.0L/3.0LX(4 cyl.)					
2816416 & BELOW	1351-3635A1	7036646	R2/2GC	18-7746	18-7200
2816417-3332137	1351-4032A1	7040080	R2/2GC	18-7746	18-7200
3332138-3771644	1351-4293A1	7040084	R2/2GC	18-7746	18-7200
3771645-5157668	1351-5203A1	7043184	R2/2GC	18-7746	18-7200
5157669-6229717	1351-7355A1	17059052	R2/2GC	18-7746	18-7200
6229718-C856558	1351-8480A2	17081060	R2/2GC	18-7746	18-7200
6229718-C856558	1389-8490A2	N/A	M2/Mercarb	18-7097	18-7202
6229718-C856558	1389-9350A2	N/A	M2/Mercarb	18-7097	18-7202
6229718-C856558	1389-9562A1	N/A	M2/Mercarb	18-7098-1	18-7202
C856559 & ABOVE	1389-815396A2	N/A	M2/Mercarb	18-7098-1	18-7202
C856559 & ABOVE	1389-815397A2	N/A	M2/Mercarb	18-7098-1	18-7202
MCM 140 (6 cyl)					
ALL (BC)	1338-2161	7025638	R1/BC	18-7071	—

① Does not include metering rods

CARBURETOR KIT/FLOAT APPLICATION (Cont.)

Model & Serial #	Mercury Carb #	Mfg. Carb #	Carb. Code & Model	Carb Kit ①	Float
ALL (B)	1338-2166	7025662	R1/B	18-7071	—
MCM 150					
1823489 & BELOW	1338-2428	7024180	R1/BC	18-7071	—
1823489 & BELOW	1338-2431	7024181	R1/B	18-7071	—
1823490-1830151	1338-2608	7025183	R1/BC	18-7071	—
1823490-1830151	1338-2609	7025184	R1/B	18-7071	—
1830152 & ABOVE	1338-2633	7025188	R2/2GC	18-7070	18-7200
MCM 160					
2492035 & BELOW	1338-2991	7026088	R2/2GC	18-7746	18-7200
2492036 & ABOVE	1351-3635A1	7036646	R2/2GC	18-7746	18-7200
MCM 165 (6 cyl)					
3354701 & BELOW	1351-4282A1	7040083	R2/2GC	18-7746	18-7200
3354702-3774864	1351-4871A1	7042183	R2/2GC	18-7746	18-7200
3774865-5178958	1351-5204A1	7043183	R2/2GC	18-7746	18-7200
5178959 & ABOVE	1351-7356A1	17059050	R2/2GC	18-7746	18-7200
MCM 165/170/3.7L (4 cyl)					
6218037-6916778	1389-8489A5	N/A	M2/Mercarb	18-7097	18-7202
6916779 & ABOVE	1389-9564A1	N/A	M2/Mercarb	18-7098-1	18-7202
MCM 175/4.3L/185 (V-6)	3304-9565A1	N/A	M2/Mercarb	18-7098-1	18-7202
(229 CID) ALL					
A221455-D714106	3300-8886A2	17083515	R4/4MV	18-7095	18-7201
185 (262 CID)					
A221455-B527954	3304-9353A2	N/A	M2/Mercarb	18-7097	18-7202
MCM 205 (262 CID)	3304-9354A2	—	R4/4MV	18-7095	18-7201
A331455-D714369	3304-9565A1	N/A	M2/Mercarb	18-7098-1	18-7202
MCM/MIE 470 ALL	1376-5990A1	17057132	R2/2GC	18-7076	18-7202
MCM 485 ALL	1376-5990A1	17057132	R2/2GC	18-7076	18-7202
MCM 488 ALL	1347-8460A3	17081299	R4/4ME	18-7077	18-7201
MCM 888					
ALL HOLLEY	1356-4642	D1JJ-9510-8	H2/2300	18-7081	18-7206
ALL ROCHESTER	1376-5659A1	7044185	R2/2GC	18-7075	18-7202
MCM 180/190/3.7LX					
(4 cyl)	1347-9142A2	17083522	R4/4MV	18-7095	18-7201
MIE 198/200/5.0L					
6021383 & BELOW	1376-6491A1	17057139	R2/2GV	18-7075	18-7202
6021384 & ABOVE	1376-8295A3	17080350	R2/2GV	18-7075	18-7202
MCM 200 (6 cyl)					
2494935 & BELOW	1347-3237A2	7037082	R4/4MV	18-7072	18-7201
2494936 & ABOVE	1347-3237A4	7037082	R4/4MV	18-7072	18-7201
MCM 898/200/5.0L					
6218462 & ABOVE	1389-8488A2	N/A	M2/Mercarb	18-7097	18-7202
6218462 & ABOVE	1389-9563A1	N/A	M2/Mercarb	18-7098-1	18-7202
6218462 & ABOVE	1389-9670A2	N/A	M2/Mercarb	18-7098-1	18-7202
MCM 205/4.3LX (V-6 262 CID)					
A331455-D714369	3304-9354A2	17084516	R4/4MV	18-7095	18-7201
MCM/MIE 215 ALL	1356-4066	C9FF-9510-E	H4/4160	18-7096	18-7206
MCM/MIE 225 (FORD)					
ALL	1356-5155	D2JL-9510-C	H4/4160	18-7096	18-7206
MCM/MIE 225 (GM)	1337-2103	7025564	R4/4GC	18-7078	—
1536920-2694014	1337-2604	7025756	R4/4GC	18-7078	—
	1347-3353	7037082	R4/4MV	18-7072	18-7201
	1347-3237A3	7037082	R4/4MV	18-7072	18-7201
MCM 228					
5069430 & BELOW	1347-6427A1	17057282	R4/4MV	18-7072	18-7201
MCM 228TR/ MIE 228					
5069430 & BELOW	1347-6438A1	17057283	R4/4MV	18-7072	18-7201
MCM 228/230/5.0L					
5069431-6021783	1347-7361A1	17059292	R4/4MV	18-7095	

① Does not include metering rods

CARBURETOR KIT/FLOAT APPLICATION (Cont.)

Model & Serial #	MerCruiser Carb #	Mfg. Carb #	Carb. Code & Model	Carb Kit ①	Float
6021784-6218461	1347-8296A4	17080565	R4/4MV	18-7095	18-7201
6218462 & ABOVE	1347-9661A3	—	R4/4MV	18-7095	18-7201
MIE 228					
5067431-6040745	1347-7364A1	17059291	R4/4MV	18-7095	18-7201
6040746 & ABOVE	1347-8290A1	17080564	R4/4MV	18-7095	18-7201
MIE 230/5.0L ALL	1347-8290A1	17080564	R4/4MV	18-7095	18-7201
230/5.0LX	1347-9661A3	—	R4/4MV	18-7095	18-7201
MCM/MIE 233					
4465029 & BELOW	1376-5744A1	7044187	R2/2GC	18-7075	18-7202
4465030 & ABOVE	1376-6152A1	17056197	R2/2GC	18-7075	18-7202
MCM/MIE 250 AUTO. CHOKE					
4767999 & BELOW	1347-3353	7037082	R4/4MV	18-7072	18-7201
MCM/MIE 250 (EL. CHOKE)					
4767999 & BELOW	1347-3237A3	7037082	R4/4MV	18-7072	18-7201
MCM 250					
4768000 & ABOVE	1347-6492A1	17057298	R4/4MV	18-7072	18-7201
MCM/MIE 255 (GM)					
4924564 & BELOW	1347-5732A1	7044291	R4/4MV	18-7072	18-7201
4924565-5195908	1347-7062A1	17057295	R4/4MV	18-7072	18-7201
5195909-5907067	1347-7365A1	17059289	R4/4MV	18-7095	18-7201
5907068 & ABOVE	1347-8289A1	17080562	R4/4MV	18-7095	18-7201
MCM/MIE 255 (FORD)					
ALL	1356-5169	D2JL-9510E	H4/4160	18-7096	18-7206
MCM 260/5.7L BRAVO					
5060805 & BELOW	1347-6492A1	17057298	R4/4MV	18-7072	18-7201
5060806-6024393	1347-7362A1	17059288	R4/4MV	18-7095	18-7201
6024394-B525981	1347-8292A4	17080561	R4/4MV	18-7095	18-7201
B525982 & ABOVE	1347-9662A4	—	R4/4MV	18-7095	18-7201
MIE 260/5.7L 350 MAG					
A635178-D617327	1347-8289A1	17080562	R4/4MV	18-7095	18-7201
MIE 5.7 SKI					
A339533-F205099	1347-9415T	17085013	R4/4MV	18-7095	18-7201
MCM/MIE 270 ALL	1347-4180A1	7029285	R4/4MV	18-7072	18-7201
MCM 280					
4176468 & BELOW	1347-4179A2	7040283	R4/4MV	18-7072	18-7201
4176469 & ABOVE	1347-5981A1	7044290	R4/4MV	18-7072	18-7201
MCM 300 MR/TRS (GM)					
6668677 & ABOVE	1347-7498A7	—	R4/4MV	18-7095	18-7201
MCM/MIE 325 AUTO. CHOKE					
3042730 & BELOW	1347-3342	7027080	R4/4MV	18-7072	18-7201
3042731 & ABOVE	1347-4533A1	7041831	R4/4MV	18-7072	18-7201
MCM/MIE 325 EL. CHOKE					
2278747-378099	1347-3689A1	7029280	R4/4MV	18-7072	18-7201
MCM 330/454 MAGNUM (ALPHA ONE)					
5027230 & BELOW	1347-6493A1	17057287	R4/4MV	18-7072	18-7201
5027231-6083144	1347-7363A1	17059290	R4/4MV	18-7095	18-7201
6083145 & ABOVE	1347-8291A3	17080563	R4/4MV	18-7095	18-7201
MIE 330					
5226384 & BELOW	1347-6493A1	17057287	R4/4MV	18-7072	18-7201
5226385 & ABOVE	1347-7366A1	17059287	R4/4MV	18-7095	18-7201
MIE 340/7.4L					
ALL	1347-8288A1	17080560	R4/4MV	18-7095	18-7201
MCM 350 MAGNUM/5.7L BRAVO					
B525992-317327	1347-8289A1	—	R4/4MV	18-7095	18-7201
MIE 350 ALL	1347-5326A2	17065977	R4/4MV	18-7072	18-7201
MCM 370/400 ALL	1347-7498A2	17059280	R4/4MV	18-7095	18-7201
MCM 7.4L (BRAVO ONE)	1347-8291A3	17080563	R4/4MV	18-7095	18-7201
MCM 454 7.4L					

① Does not include metering rods

CARBURETOR KIT/FLOAT APPLICATION (Cont.)

Model & Serial #	Mercuriser Carb #	Mfg. Carb #	Carb. Code & Model	Carb Kit ①	Float
6083145-B816540	—	—	H4/4150, R6647A	18-7728	—
MCM 454 MAGNUM					
(BRAVO ONE)	1347-7498A2	17059280	R4/4MV	18-7095	18-7201
ALL	1347-9863A3	—	R4/4MV	18-7095	18-7201
MCM 502 MAGNUM (BRAVO ONE)					
C878221-D857199	1347-814623A2	—	R4/4MV	18-7095	18-7201
MCM 8.2L	1347-814623A2	—	R4/4MV	18-7095	18-7201

① Does not include metering rods



18-7228
FLAME ARRESTOR
Replaces: 85784A1



18-7229
FLAME ARRESTOR
Replaces: 85785T, 85785-2



18-7230
FLAME ARRESTOR
Replaces: 41639A1, 41639



18-7231
FLAME ARRESTOR
Replaces: 85785A2



18-7232
FLAME ARRESTOR
Replaces: 57882, 57882T



18-7234
FLAME ARRESTOR
Replaces: 805016A1

ALL SIERRA FUEL PUMPS INCLUDE MOUNTING GASKET

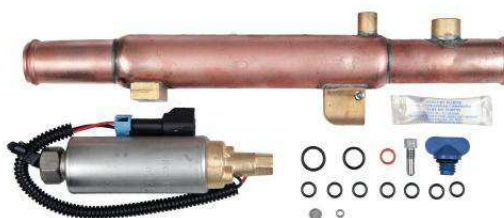

18-8861
FUEL PUMP W/ COOLER
Replaces: 861156A02
For: GM V-6/ V-8 EFI 0L000000-0M299999



18-8862
FUEL PUMP W/ COOLER
Replaces: 861156A03
For: GM V-6/ V-8 EFI 0M300000

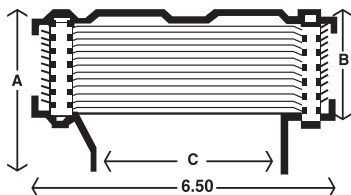

ANODIZED ALUMINUM FLAME ARRESTOR SPECIFICATIONS

Engine	Part No.	Height A	Element B	Throat C	Vent Tubes*
4 & 6 cyl.	18-7228	2.156	1.088	3.12	1
4 & 6 cyl. ①	18-7234	2.28	1.55	3.1	0
V-8	18-7229	2.25	1.47	5.05	0
V-8	18-7230	2.25	1.47	5.05	1
V-8	18-7231	2.25	1.47	5.05	2
Hi-Performance	18-7232	2.969	2.19	5.05	2

① 7" Outside diameter * Vent tubes accept 5/8 inch ID hose



18-8864
FUEL PUMP W/ REGULATOR
Replaces: 866169T01, 866169A01
For: Gm V-8 with Gen III Cool Fuel Module-high pressure



18-8865
FUEL PUMP
Replaces: 866170A01
For: Gm V-8 with Gen III Cool Fuel Module-low pressure



18-8867
FUEL PUMP
Replaces: 861155A6, 861155A5, 805656A6, 805656A5, 805656A2, 805025A2
For: 4.3L V-6



18-8868
FUEL PUMP
Both ends threaded
Replaces: 861155A3, 861155A2
For: 5.0/ 5.7L V-8 & 4.3L



18-7326
ELECTRIC FUEL PUMP
Replaces: 805656A2, 805656A6, 805656A5, 805025A2, 861155A6, 861155A5
For: 1992-93, 1996 F.I. & Carbureted 4.3L with inline electric pump



18-35433
ELECTRIC FUEL PUMP
One end threaded, One end snap fitting
Replaces: 861156A1
Fits: Mercruiser V6 & V8 305/350/377/454/502 EFI (Non-Threaded)(Replaces Cool Fuel Pump)



18-7266
FUEL PUMP
Flange I.D. # 41413, M6696
For: Ford (V-8) 302, 351



18-7267
FUEL PUMP
Flange I.D. # 41414
Replaces: 62092T, 62092, 54552
For: Ford (V-8) 302
(Includes gasket)



18-7274
FUEL PUMP
Flange I.D. # 41421, M73021
Replaces: 86246, 86246A1, 78485, 71646
For: GM (V-8) 305, 350, 400, 228 / 250 / 255 / 260 / 280



18-7275
FUEL PUMP
Flange I.D. # 41422
Replaces: 86247, 86247T, 86247A2, 78820, 63196, 46860
For: GM (V-8) 454, 330 / 325 / 350 / 390
(Includes gasket)



18-7278
FUEL PUMP
Flange I.D. # M60032
Replaces: 86234A4, 86234A05, 86234A3, 86234, 77594, 71327, 47585
For: GM (4 & 6 Cyl.) 153, 181, 225, 250, 120 / 140 / 160 / 165 / 470 / 485 / 488
Uses filter **18-7860** & gasket **18-0889**



18-7282
FUEL PUMP
Flange I.D. # M60337
Replaces: 8M0073435, 861676T09
For: GM 4 cyl. (2.5/3.0L) & Mercruiser 3.7L
Uses filter **18-7784** & gasket **18-0889**



18-7283
FUEL PUMP
Flange I.D. # M60600
Replaces: 97401A2, 97401A8, 861678A1, 8M0058164, 97401
For: GM (V-8) 305, 350, 228 / 230 / 260 / 898
Uses gasket **18-0889**



18-7284
FUEL PUMP
Flange I.D. # M60315
Replaces: 41141A2, 862077A1
For: GM (V-6) 231, 262, 229
Uses filter **18-7784** & gasket **18-0889**



18-7288-1
FUEL PUMP
Flange I.D. #60601
Replaces: 812454A1, 862048A1, 812454A3, 97399A2, 97399
For: Inline (4 cyl) 120, 140, 3.0L and 224 CID
7.4L / 454 / 420 / 330



18-35437
FUEL PUMP
Replaces: 42725A3, 861676A1, 861676T09, 8M0073435
Fits: Mercruiser 3.0L (SN L097000 & Up)
(Includes gasket)



18-8860
FUEL PUMP
Replaces: 861677T
For: GM V-8 (454 & 502) applications
(Includes gasket)



18-7256
FUEL PUMP
Flange I.D. # 6790, M3530
Replaces: 32722
For: GM (4 & 6 Cyl.) 153, 230, 250, 292

APPLICATION ON NEXT PAGE

FUEL PUMP APPLICATION

Model	CID/#CYL	Year Range	Beginning Serial #	Ending Serial #	Fuel Pump #1	Fuel Pump #2	Pump Filter
120	153/L4	1964-1972	1666601	3377340	18-7278 ①	—	18-7860
120	153/L4	1964-1972	1666601	3377340	18-7256 ②	—	—
120	153/L4	1972-1982	3377341	6229717	18-7278	—	18-7860
120	153/L4	1983-1986	6229718	B531853	18-7278 ③	—	18-7860
120			4469866	& Below	18-7278	—	—
120			4469866	4952700	18-7278	—	—
120			4952701	& Up	18-7278	—	—
120			5192049	6229717	18-7278	—	—
120/2.5L			6229718	& Up	18-7278	—	—
120/2.5L			6229718	& Up	18-7282	—	—
2.5L	153/L4	1987-1989	B531854	BC853255	18-7278 ④	—	18-7860
140 (4 CYL)	181/L4	1968-1982	2508261	6229717	18-7278	—	18-7860
140 (4 CYL)	181/L4	1983-1986	6229718	B450800	18-7278 ⑤	—	18-7860
3.0L	181/L4	1987-1989	B450801	C856558	18-7278 ⑥	—	18-7860
140			4460664 & Below	& Below	18-7278	—	—
140			4460665	4918569	18-7278	—	—
140			4918570	& Up	18-7278	—	—
140 (4 Cyl.)			5157669	6229717	18-7278	—	—
140/3.0L			6229717 & Below	& Below	18-7278	—	—
140/3.0L			6229718 & Up	& Up	18-7282	—	—
3.0L/3.0LX			C856559 & Up	& Up	18-7282	—	—
140 (6 Cyl.)			1538930	1725960	18-7256	—	—
150			1666495	2048046	18-7256	—	—
160			2048022	2770031	18-7278	—	—
165			4471566	4884834	18-7278	—	—
165			5178959 & Up	& Up	18-7278	—	—
165/3.7L (4 Cyl.)			6916779 & Up	& Up	18-7282	—	—
180/3.7-LX (4 Cyl.)			6916779 & Up	& Up	18-7282	—	—
175/4.3L (262 CID)			B527955 & Up	& Up	18-7284	—	—
185 (229 CID)			6330183 & Up	& Up	18-7284	—	—
185 (262 CID)			A331455 & Up	& Up	18-7284	—	—
470	224/L4	1976-1984	4208730	6916778	18-7278	—	18-7860
485	224/L4	1980-1982	5685394	6218036	18-7278	—	18-7860
488	224/L4	1983-1984	6170297	6916778	18-7278 ⑦	—	18-7860
140 (6 CYL)	194/L6	1963	1538930	1725960	18-7256	—	—
150	230/L6	1964-1966	1666495	2048046	18-7256	—	—
160	250/L6	1967-1969	2048022	2770031	18-7278 ⑧	—	18-7860
160	250/L6	1967-1969	2048022	2770031	18-7256 ⑨	—	—
165 (6 CYL)	250/L6	1979-1981	2770032	5813433	18-7278	—	18-7860
200 (6 CYL)	250/L6	1969	2453769	2712072	18-7278	—	18-7860
200 GM			6218462	& Up	18-7283	—	—
200/5.0L GM			B525982	& Up	18-7283	—	—
185 (4bbl)	229/V-6	1983-1984	6330183	6919655	18-7284	—	—
175	262/V-6	1987	B527955	B773242	18-7284	—	—
185 (2bbl)	262/V-6	1985-1986	A331455	B527954	18-7284	—	—
205	262/V-6	1985-1987	A331455	B775129	18-7284	—	—
205/4.3L-LX (262 CID)			B527955	& Up	18-7284	—	—
262 MAG EFI (GEN +)	262/V-6	1996-1997	F803800	K999999	18-8867	—	—
4.3L	262/V-6	1988-1992	B773243	D714106	18-7284	—	—
4.3L (GEN II)	262/V-6	1992-1996	D714107	F802999	18-8867	—	—
4.3L (GEN +)	262/V-6	1998-2010	L012009	& Up	18-8868	—	—

- ① low pressure lift pump
- ② high pressure fuel cool pump
- ③ fuel pump mounted with filter bowl facing up
- ④ fuel pump mounted with filter bowl facing down
- ⑤ AC fuel pump

- ⑥ Carter fuel pump
- ⑦ mechanical fuel pump
- ⑧ use if fuel pump has sight glass
- ⑨ use if fuel pump has sight tube
- ⑩ fuel pump/cooler kit

FUEL PUMP APPLICATION

Model	CID/#CYL	Year Range	Beginning Serial #	Ending Serial #	Fuel Pump #1	Fuel Pump #2	Pump Filter
4.3L EFI (GEN +)	262/V-6	1998-2001	L012009	M299999	18-8861 ⑩	—	—
4.3L MPI	262/V-6	2002-2010	M300000	& Up	18-8862 ⑩	—	—
4.3LH (GEN+)	262/V-6	1998-2002	L010044	M614999	18-8868	—	—
4.3LX	262/V-6	1988-1992	B775130	D714369	18-7284	—	—
4.3LX (GEN II)	262/V-6	1992-1996	D714107	F802999	18-8867	—	—
4.3LX (GEN +)	262/V-6	1996-1997	F803000	K999999	18-8867	—	—
4.3LXH (GEN +)	262/V-6	1996-1997	F803114	K999999	18-8867	—	—
215 (FORD)	302/V-8	1970-1972	2781153	3563181	18-7267	—	—
215 Ford			3085036	& Below	18-7267	—	—
215 Ford			3258182	& Up	18-7267	—	—
225 Ford	302/V-8	1973-1974	3385721	4166999	18-7267	—	—
228 MCM & MIE	305/V-8	1977-1978	4765100	5170008	18-7274	—	—
228 MCM & MIE	305/V-8	1979-1982	5170009	6218461	18-7274	—	—
228 MCM & MIE	305/V-8	1979-1982	5170009	6218461	18-7283 ⑤	—	—
888 (FORD)	302/V-8	1971-1977	3108723	4887829	18-7267	—	—
228	305/V-8	1982-1984	6218462	6899268	18-7283	—	—
230 MIE	305/V-8	1981-1987	5907058	B788151	18-7283	—	—
230/5.0L-GM (IB)			B522506	& Up	18-7283	—	—
230 GM			6218462	& Up	18-7283	—	—
230/5.0L-LX GM			B525982	& Up	18-7283	—	—
230	305/V-8	1985-1987	6899269	B773739	18-7283	—	—
5.0L	305/V-8	1988-1995	B774445	F600999	18-7283	—	—
5.0L (GEN +)	305/V-8	1998-2010	L015751	& Up	18-8868	—	—
5.0L EFI (GEN +)	305/V-8	1998-2001	L012052	M299999	18-8861 ⑩	—	—
5.0L MIE	305/V-8	1988	B788152	C396832	18-7283	—	—
5.0L MPI ALPHA	305/V-8	2002-2010	M300000	& Up	18-8862 ②, ⑩	18-8868 ①	—
5.0L MPI BRAVO	305/V-8	2002-2004	M300000	W059999	18-8862 ②, ⑩	18-8868 ①	—
5.0L MPI BRAVO	305/V-8	2004-2010	W060000	& Up	18-8864 ②	18-8865 ①	—
5.0LX	305/V-8	1988-1995	B773740	F600999	18-7283	—	—
898	305/V-8	1977-1982	4762210	6218461	18-7274 ⑤	—	—
898	305/V-8	1977-1982	4762210	6218461	18-7283 ⑤	—	—
898	305/V-8	1983-1984	6218462	6899057	18-7283	—	—
233 FORD			4500860	& Up	18-7267	—	—
250	350/V-8	1977	4768000	4908849	18-7274	—	—
255	350/V-8	1975-1976	4175500	4767999	18-7274	—	—
255 MIE (GM)	350/V-8	1975-1980	4175500	5907057	18-7274	—	—
255 FORD			3258728	& Up	18-7267	—	—
255 GM			5195909	& Up	18-7274	—	—
260	350/V-8	1978-1982	4908850	6218461	18-7274 ⑤	—	—
260	350/V-8	1978-1982	4908850	6218461	18-7283 ⑤	—	—
260	350/V-8	1983-1987	6218461	& Up	18-7283	—	—
260 MIE	350/V-8	1981-1987	5907058	B788151	18-7283	—	—
260/5.7 GM			B525982	& Up	18-7283	—	—
260 GM Inboard			5907058	& Up	18-7283	—	—
260/5.7L GM (IB)			5907058	& Up	18-7283	—	—
5.7L-GM			F025000	& Up	18-7283	—	—
280	350/V-8	1975-1976	4176250	4770199	18-7274	—	—
300MR/TRS GM	350/V-8	1985-1986	6668677	B430367	18-7283	—	—
320 EFI	350/V-8	1987-1989	A543604	C622418	N.L.A	—	—
325-GM			2278747	3640670	18-7275	—	—
330 GM			4623115	& Up	18-7275	—	—
330 GM/W.B.W.			6083145	& Up	18-7288-1	—	—
340/7.4L-GM (IB)			5889914	& Up	18-7288-1	—	—

- ① low pressure lift pump
- ② high pressure fuel cool pump
- ③ fuel pump mounted with filter bowl facing up
- ④ fuel pump mounted with filter bowl facing down
- ⑤ AC fuel pump

- ⑥ Carter fuel pump
- ⑦ mechanical fuel pump
- ⑧ use if fuel pump has sight glass
- ⑨ use if fuel pump has sight tube
- ⑩ fuel pump/cooler kit

FUEL PUMP APPLICATION

Model	CID/#CYL	Year Range	Beginning Serial #	Ending Serial #	Fuel Pump #1	Fuel Pump #2	Pump Filter
350 MAG ALPHA	350/V-8	1986-1997	A635178	K999999	18-7283	—	—
350 MAG ALPHA EFI (GEN +)	350/V-8	1996	F800300	K001508	18-7283	—	—
350 MAG ALPHA EFI (GEN +)	350/V-8	1997	K001509	K999999	—	—	—
350 MAG BRAVO MPI	350/V-8	1995-1996	F415189	K001500	18-7283	—	—
350 MAG BRAVO MPI	350/V-8	1997	K001501	K999999	—	—	—
350 MAG EFI SKI	350/V-8	1994-1997	F215561	K999999	—	—	—
350 MAG MPI	350/V-8	1998-2001	L010019	M299999	18-8861 ①	—	—
350 MAG MPI ALPHA	350/V-8	2002-2010	M300000	& Up	18-8862 ②	18-8868 ①	—
350 MAG MPI BRAVO	350/V-8	2002-2004	M300000	W059999	18-8862 ②, ⑩	18-8868 ①	—
350 MAG MPI BRAVO	350/V-8	2004-2010	W060000	& Up	18-8864 ②	18-8865 ①	—
350 MAG MPI HORIZON	350/V-8	2002-2004	M300000	W059999	18-8862 ②, ⑩	18-8868 ①	—
350 MAG MPI HORIZON	350/V-8	2004-2007	W060000	A299999	18-8864 ②	18-8865 ①	—
350 MAG MPI HORIZON MIE	350/V-8	1999-2001	L304700	M299999	18-8861 ③	— ①	—
350 MAG MPI HORIZON MIE	350/V-8	2002-2004	M300000	M398371	18-8862 ②, ⑩	18-8868 ①	—
350 MAG MPI HORIZON MIE	350/V-8	2004-2007	M398372	A089999	18-8864 ②	18-8865 ①	—
350 MAG MPI MIE	350/V-8	1998-2001	L002008	M299999	18-8861 ⑩	—	—
350 MAG MPI MIE	350/V-8	2002-2004	M300000	M398371	18-8862 ②, ⑩	18-8868 ①	—
350 MAG MPI MIE	350/V-8	2004-2007	M398372	A089999	18-8864 ②	18-8865 ①	—
350 MAG MPI MIE	350/V-8	1998-2001	L002008	M299999	18-8861 ⑩	—	—
350 MAG MPI MIE	350/V-8	2002-2004	M300000	M398371	18-8862 ②, ⑩	18-8868 ①	—
350 MAG MPI MIE	350/V-8	2004-2007	M398372	A089999	18-8864 ②	18-8865 ①	—
350 MAG MPI SKI	350/V-8	1995-1996	F350583	F799999	18-7283	—	—
350 MAG MPI SKI (GEN +)	350/V-8	1998-2001	L002600	M299999	18-8861 ⑩	—	—
350 MAG MPI SKI (GEN +)	350/V-8	2002-2007	M300000	A089999	18-8862 ⑩	18-8868 ①	—
350 MAG SKI	350/V-8	1991-1997	D505450	K999999	18-7283	—	—
350 GM			3780450	& Up	18-7275	—	—
(MAG-TOURNEY SKI)			D505450	& Up	18-7283	—	—
370 TRS-GM			6721528	& Up	18-7288-1	—	—
390-GM			2781129 - 2825059	2825059	18-7275	—	—
5.7L	350/V-8	1988-1997	B773305	K999999	18-7283	—	—
5.7L (GEN +)	350/V-8	1998-2010	L010037	& Up	18-8868	—	—
5.7L EFI	350/V-8	1995-1996	F225560	K001505	18-7283	—	—
5.7L EFI	350/V-8	1997-2001	K001506	M299999	18-8861 ⑩	—	—
5.7L MIE	350/V-8	1988-1997	B788152	K999999	18-7283	—	—
5.7L MIE (GEN +)	350/V-8	1998-2010	L002003	& Up	18-8868	—	—
5.7L MPI HORIZON MIE	350/V-8	2008-2010	A090000	& Up	18-8864 ②	18-8865 ①	—
5.7L MPI MIE	350/V-8	2008-2010	A090000	& Up	18-8864 ②	18-8865 ①	—
5.7L MPI SKI	350/V-8	2008-2010	A090000	& Up	18-8862 ②, ⑩	18-8868 ①	—
5.7L SKI	350/V-8	1985-1997	A338553	K999999	18-7283	—	—
5.7L SKI (GEN +)	350/V-8	1998-2010	L002005	& Up	18-8868	—	—
5.7LX	350/V-8	1996-1997	F601000	K999999	18-7283	—	—
5.7LX BRAVO EFI (GEN +)	350/V-8	1996	F800300	K001508	18-7283	—	—
5.7LX BRAVO EFI (GEN +)	350/V-8	1997	K001509	K999999	—	—	—
5.7LX EFI	350/V-8	1996	F752400	K001505	18-7283	—	—
5.7LX EFI	350/V-8	1997	K001506	K999999	—	—	—
5.7 GM (SKI)			B514627	& Up	18-7283	—	—
5.7L BRAVO (GM)350			B525982	& Up	18-7283	—	—
BLACK SCORPION SKI	350/V-8	1997	K040001	K999999	—	—	—
BLACK SCORPION SKI	350/V-8	1998-2001	L000000	L679175	18-8861 ②, ⑩	—	—
BLACK SCORPION SKI	350/V-8	2001-2007	L679176	W698432	18-8861 ②, ⑩	18-8868 ①	—
SCORPION 350	350/V-8	2008-2010	W698433	& Up	18-8861 ②, ⑩	18-8868 ①	—

- ① low pressure lift pump
- ② high pressure fuel cool pump
- ③ fuel pump mounted with filter bowl facing up
- ④ fuel pump mounted with filter bowl facing down
- ⑤ AC fuel pump

- ⑥ Carter fuel pump
- ⑦ mechanical fuel pump
- ⑧ use if fuel pump has sight glass
- ⑨ use if fuel pump has sight tube
- ⑩ fuel pump/cooler kit

FUEL PUMP APPLICATION

Model	CID#CYL	Year Range	Beginning Serial #	Ending Serial #	Fuel Pump #1	Fuel Pump #2	Pump Filter
SCORPION 350 EC	350/V-8	2009-2010	W698433	& Up	18-8864 ②	18-8864 ①	—
233 (FORD)	351/V-8	1975-1977	4173000	4902304	18-7267	—	—
255 (FORD)	351/V-8	1973-1974	3258728	4175499	18-7267	—	—
377 MAG	377/V-8	2008-2010	A300000	& Up	18-8864 ②	18-8865 ①	—
377 SCORPION MCM	377/V-8	1999-2005	L416146	M907201	18-8861 ⑩	—	—
377 SCORPION SKI	377/V-8	1997-1998	K00656	L600314	18-8861 ⑩	—	—
MX 6.2L MPI	377/V-8	2000-2001	L680003	M299999	18-8861 ⑩	—	—
MX 6.2L MPI	377/V-8	2002-2004	M300000	W059999	18-8862 ②, ⑩	18-8868 ①	—
MX 6.2L MPI	377/V-8	2004-2007	W060000	A299999	18-8864 ②	18-8865 ①	—
MX 6.2L MPI HORIZON	377/V-8	2002-2004	M300000	W059999	18-8862 ②, ⑩	18-8868 ①	—
MX 6.2L MPI HORIZON	377/V-8	2004-2007	W060000	A299999	18-8864 ②	18-8865 ①	—
MX 6.2L MPI HORIZON MIE	377/V-8	2002-2004	M300000	M398394	18-8862 ②, ⑩	18-8868 ①	—
MX 6.2L MPI HORIZON MIE	377/V-8	2004-2010	M398395	& Up	18-8864 ②	18-8865 ①	—
MX 6.2L MPI MIE	377/V-8	2002-2004	M300000	M398394	18-8862 ②, ⑩	18-8868 ①	—
MX 6.2L MPI MIE	377/V-8	2004-2010	M398395	& Up	18-8864 ②	18-8865 ①	—
MX 6.2L MPI SKI	377/V-8	2002-2010	M317000	& Up	18-8862 ②, ⑩	18-8868 ①	—
MX 6.2L BLACK SCORPION SKI	377/V-8	2001	L670015	L679175	18-8861 ⑩	—	—
MX 6.2L BLACK SCORPION SKI	377/V-8	2001-2007	L679176	W698432	18-8861 ②, ⑩	18-8868 ①	—
SCORPION 377	377/V-8	2008-2010	W698433	& Up	18-8861 ②, ⑩	18-8868 ①	—
SCORPION 377 HO EC	377/V-8	2009-2010	A091488	A092170	18-8864 ②	18-8865 ①	—
325	427/V-8	1969-1972	2278747	3780449	18-7275	—	—
330	454/V-8	1977-1981	4623115	6083144	18-7275	—	—
330 WITH B/W	454/V-8	1982-1987	6083145	B816540	18-7288-1	—	—
340 MIE	454/V-8	1981-1987	5889914	B788365	18-7288-1	—	—
350 MIE	454/V-8	1974-1976	3780450	4623109	18-7275	—	—
370 TRS	454/V-8	1978-1987	4179554	B714586	18-7288-1	—	—
400 TRS	454/V-8	1980-1986	4179554	B457644	18-7288-1	—	—
420	454/V-8	1987-1989	A398941	B622418	18-7288-1	—	—
425-GM			A398941	& Up	18-7288-1	—	—
425	454/V-8	1990-1992	B622419	D725499	18-7288-1	—	—
425 (GEN V)	454/V-8	1992-1993	D763855	D937011	18-8860	—	—
440 TRS	454/V-8	1983-1986	4179554	B485220	18-7288-1	—	—
450	454/V-8	1995-1996	F347100	F347277	18-8860	—	—
454 MAG ALPHA	454/V-8	1986-1988	A631894	B785148	18-7288-1	—	—
454 MAG BRAVO GM			B840126	& Up	18-7288-1	—	—
454 MAG BRAVO	454/V-8	1988-1992	A631894	B785148	18-7288-1	—	—
454 MAG BRAVO	454/V-8	1992-1997	D805069	K999999	18-8860	—	—
454 MAG EFI	454/V-8	1994-1996	F115700	F802349	18-8860	—	—
454 MAG EFI SKI	454/V-8	1995-1996	F215800	F820099	18-8860	—	—
454 MAG MPI	454/V-8	1996	F802350	K147349	18-8860	—	—
454 MAG MPI	454/V-8	1997	K147350	K999999	18-8861 ⑩	—	—
454 MAG MPI	454/V-8	1998-2001	L010029	M024999	18-8861 ⑩	—	—
454 MAG MPI HORIZON MIE	454/V-8	1998-2001	L002200	L674000	18-8861 ⑩	—	—
454 MAG MPI SKI	454/V-8	1996-1997	F820100	K999999	18-8860	—	—
470			5097479	& Below	18-7278	—	—
470			5097480	& Up	18-7278	—	—
470			5520115	6218036	18-7278	—	—
470			6218037	& Up	18-7278	—	—
485			5685394	& Up	18-7278	—	—
488			6170297	& Up	18-7278	—	—

- ① low pressure lift pump
- ② high pressure fuel cool pump
- ③ fuel pump mounted with filter bowl facing up
- ④ fuel pump mounted with filter bowl facing down
- ⑤ AC fuel pump

- ⑥ Carter fuel pump
- ⑦ mechanical fuel pump
- ⑧ use if fuel pump has sight glass
- ⑨ use if fuel pump has sight tube
- ⑩ fuel pump/cooler kit

FUEL PUMP APPLICATION

Model	CID#/CYL	Year Range	Beginning Serial #	Ending Serial #	Fuel Pump #1	Fuel Pump #2	Pump Filter
525SC	454/V-8	1992-1999	D725809	L415623	18-8860	—	—
7.4L BRAVO	454/V-8	1988-1991	B771113	D603117	18-7288-1	—	—
7.4L BRAVO	454/V-8	1992-1997	D603118	K999999	18-8860	—	—
7.4L EFI MIE	454/V-8	1996-1997	F874815	K999999	—	—	—
7.4L MIE	454/V-8	1988-1992	B788366	D715493	18-7288-1	—	—
7.4L MIE	454/V-8	1992-1997	D715494	K999999	18-8860	—	—
7.4L MPI	454/V-8	1998-2001	L010003	M024330	18-8861 ⑩	—	—
7.4L MPI MIE	454/V-8	1995-1997	F563052	K147349	18-8860	—	—
7.4L MPI MIE	454/V-8	1997	K147350	K999999	—	—	—
7.4L MPI MIE	454/V-8	1997-2001	L002006	L674613	18-8861 ⑩	—	—
7.4LX BRAVO EFI	454/V-8	1996-1997	F820000	K999999	—	—	—
7.4LX BRAVO MPI	454/V-8	1996-1997	F602010	K999999	18-8860	—	—
7.4L W/HURTH (IB)			C391564	& Up	18-7288-1	—	—
390	482/V-8	1969-1970	2781129	2825059	18-7275	—	—
496 MAG & HO	496/V-8	2001-2004	M025000	W059999	18-8862 ②, ⑩	18-8868 ①	—
496 MAG & HO	496/V-8	2004-2010	W060000	& Up	18-8864 ②	18-8865 ①	—
8.1S MPI MIE & HO	496/V-8	2001-2004	M026000	W089999	18-8862 ②, ⑩	18-8868 ①	—
8.1S MPI MIE & HO	496/V-8	2004-2010	W090000	& Up	18-8864 ②	18-8865 ①	—
465	502/V-8	1992-1994	D456155	F213244	18-7275	—	—
500	502/V-8	1994-1998	F213293	L001772	18-7275	—	—
502 MAG BRAVO	502/V-8	1992-1993	D824589	F114528	18-8860	—	—
502 MAG EFI	502/V-8	1993-1995	D840650	F802599	18-8860	—	—
502 MAG MPI	502/V-8	1996	F802600	K147349	18-8860	—	—
502 MAG MPI	502/V-8	1997	K147350	K999999	—	—	—
502 MAG MPI	502/V-8	1998-2001	L017000	M024999	18-8861 ⑩	—	—
600SC	502/V-8	1992-2000	D725676	L601186	18-8860	—	—
8.2L MAG & HO	502/V-8	2010	A340340	& Up	18-8864 ②	18-8865 ①	—
8.2L MAG & HO MIE	502/V-8	2010	A350802	& Up	18-8864 ②	18-8865 ①	—
8.2L MIE	502/V-8	1993-1996	D857200	F819619	18-8860	—	—
8.2L MPI MIE	502/V-8	1996-1997	F819620	K147349	18-8860	—	—
8.2L MPI MIE	502/V-8	1997	K147350	K999999	—	—	—
8.2L MPI MIE	502/V-8	1998-2001	L002450	L674200	18-8861 ⑩	—	—

- ① low pressure lift pump
- ② high pressure fuel cool pump
- ③ fuel pump mounted with filter bowl facing up
- ④ fuel pump mounted with filter bowl facing down
- ⑤ AC fuel pump
- ⑥ Carter fuel pump
- ⑦ mechanical fuel pump
- ⑧ use if fuel pump has sight glass
- ⑨ use if fuel pump has sight tube
- ⑩ fuel pump/cooler kit

FUEL WATER SEPARATORS

Sierra fuel water separators remove over 99.8% of emulsified water from your gasoline. Sierra's 10 micron filters are over 90% efficient at removing particles as small as 10 micron. All filters flow @ 90 GPH to feed even the hungriest motor. Sierra 10 micron filters are recommended to prevent damage to sensitive inboard and outboard fuel injection systems.

- UNIVERSAL DESIGN -

DIRECT REPLACEMENT FOR MERCURY AND YAMAHA

FUEL WATER SEPARATOR BRACKETS



Bracket Type	Part No.	Replaces
1/4" Stainless Steel	18-8777	—
3/8" Stainless Steel	18-7776	—
1/4" Aluminum	18-7853-1	Mercury 89876A3, 55481, 89876
3/8" Aluminum	18-7775	—

FUEL WATER SEPARATOR KITS



21 MICRON FILTER KITS FOR CARBURETED ENGINES

Kit Type	Part No.	Micron Rating	Contents	Replaces
1/4" Aluminum (Short Filter)	18-7848-1	21	1 - 18-7844 filter & 1 18-7853-1 bracket 2 - 18-4256 1/4" pipe plugs	Mercury - 35-807172A4, Q4, 35-60494A4, 35-805369A4, 35-57250A1, 35-55501A1, 35-52456A1, 35-60494A1, 52444
1/4" Aluminum Bonus Pack (Contains spare filter)	18-7848-2	21	2 - 18-7844 filter & 1 18-7853-1 bracket 2 - 18-4256 1/4" pipe plugs	—
1/4" Aluminum (Tall Filter)	18-7852-1	21	1 - 18-7845 filter & 1 18-7853-1 bracket 2 - 18-4256 1/4" pipe plugs	—
1/4" Aluminum Bonus Pack (Contains spare filter)	18-7852-2	21	2 - 18-7845 filter & 1 18-7853-1 bracket 2 - 18-4256 1/4" pipe plugs	—
3/8" Aluminum (Tall Filter)	18-7775-1	21	1 - 18-7845 filter & 1 18-7775 bracket 2 - 18-4264 3/8" pipe plugs	—
1/4" Stainless Steel (Tall Filter)	18-7777-1	21	1 - 18-7845 filter & 1 18-7777 bracket 2 - 18-4256 1/4" pipe plugs	—
3/8" Stainless Steel (Tall Filter)	18-7776-1	21	1 - 18-7845 filter & 1 18-7776 bracket 2 - 18-4264 3/8" pipe plugs	—



10 MICRON FILTER KITS FOR FUEL INJECTED ENGINES

Kit Type	Part #	Micron Rating	Contents
1/4" Aluminum (Short Filter)	18-7983-1	10	1 - 18-7944 filter & 1 18-7853-1 bracket • 2 - 18-4256 1/4" pipe plugs
1/4" Aluminum Bonus Pack (Contains spare filter)	18-7983-2	10	2 - 18-7944 filter & 1 18-7853-1 bracket • 2 - 18-4256 1/4" pipe plugs
1/4" Aluminum (Tall Filter)	18-7982-1	10	1 - 18-7945 filter & 1 18-7853-1 bracket • 2 - 18-4256 1/4" pipe plugs
1/4" Aluminum Bonus Pack (Contains spare filter)	18-7982-2	10	2 - 18-7945 filter & 1 18-7853-1 bracket • 2 - 18-4256 1/4" pipe plugs
1/4" Aluminum (High Capacity Filter)	18-7966-1	10	1 - 18-7866 filter & 1 18-7853-1 bracket • 2 - 18-4256 1/4" pipe plugs
3/8" Aluminum (Tall Filter)	18-7986-1	10	1 - 18-7945 filter & 1 18-7775 bracket • 2 - 18-4264 3/8" pipe plugs
1/4" Stainless Steel (Tall Filter)	18-7984-1	10	1 - 18-7945 filter & 1 18-7777 bracket
3/8" Stainless Steel (Tall Filter)	18-7985-1	10	1 - 18-7945 filter & 1 18-7776 bracket • 2 - 18-4264 3/8" pipe plugs
1/4" Aluminum (Tall Filter)	18-79912	10	1 - 18-79911 & 1 - 18-7853-1

• Display Packaged

10 MICRON FILTER KITS WITH DRAIN BOWLS

Sierra AquaVue™ and metal bowl separator filters allow water to be drained from the filter to extend service life. Use the AquaVue™ bowl for outboard, above deck installations. USCG regulations require the use of the flame resistant metal bowl below deck.

- Display Packaged



Kit Type	Part #	Micron Rating	Contents
1/4" Aluminum w/ metal drain bowl	18-7951 •	10	1 - 18-7919 filter & 1 18-7853-1 bracket 1 - 18-7924 metal bowl 2 - 18-4256 1/4" pipe plugs
1/4" Stainless Steel w/ metal drain bowl	18-7938 •	10	1 - 18-7919 filter & 1 18-7777 bracket 1 - 18-7924 metal bowl 2 - 18-4256 1/4" pipe plugs

COMPACT BRACKET AND SEPARATOR KIT - FOR SMALL OUTBOARDS AND FRESH WATER APPLICATIONS



18-7774
COMPACT ALUMINUM BRACKET



18-7965-1
10 MICRON COMPACT SEPARATOR KIT

Contains:
1 - 18-7774 bracket
1 - 18-7865 filter



REPLACEMENT FILTERS



UNIVERSAL DESIGN - DIRECT REPLACEMENT FOR MERCURY

10 MICRON REPLACEMENT FILTERS

Part No.	Description	Replaces
18-7944	Short - 3.875"	35-807172, 35-802893Q, 35-806771, 35-8053691, 35-805369, 35-604941, 35-60494, 35-57250, 35-55501, 35-52456
18-7945	Long - 8.5"	35-802893Q, 35-806771, 35-8053691, 35-805369, 35-604941, 35-60494, 35-57250, 35-55501, 35-52456
18-7866	High Capacity - 6"	—

10 MICRON REPLACEMENT FILTERS

Part No.	Description	Replaces
18-7865	Compact 10 Micron	—
18-79911	Long - 8.5"	35-8M0079962

21 MICRON REPLACEMENT FILTERS

Part No.	Description	Replaces
18-7844	Short - 3.875"	35-807172, 35-802893Q
18-7845	Long - 4.35"	35-807172, 35-806771, 35-8053691, 35-60494A4, 35-604941, 35-57250, 35-55501

10 MICRON REPLACEMENT FILTERS AND KITS WITH DRAIN BOWLS



REPLACEMENT FILTERS

Part No.	Description	Replaces
18-7919	Spin-on replacement	35-809097, 35-8M0103095 Racor S3213
18-7920	Spin-on replacement	Mercury 35-809099 Racor S3214
18-7947	Spin-on replacement	Racor S3240
18-7948	Spin-on replacement Fits: 320RRAC01	35-886638 Racor S3227
18-7949	Spin-on replacement Fits: 660RRAC02	Racor S3232

REPLACEMENT BOWLS

Part No.	Description
18-7924	Metal Collection Bowl

FILTER & BOWL KITS

Part No.	Description
18-7929 •	Filter & Metal Bowl, Mercury Style Contains: 18-7919 filter & 18-7924 bowl
18-7943 •	Filter & Metal Bowl, Contains: 18-7920 filter & 18-7924 bowl
18-7969 •	Filter & Metal Bowl, Contains: 18-7948 filter & 18-7924 bowl

- Display Packaged



18-7919
FUEL/WATER SEPARATING FILTER
Replaces: Mercruiser 35-809097, 35-8M0103095 and Racor™ S3213
For: styles with spin on drain bowls



18-8955
FUEL WATER SEPARATOR COVER
Fits: 18-7944 & 18-7945 sized filter



18-7784
FUEL FILTER
Replaces: Mercruiser 35-11004A1, 35-803897Q1
For: 2.5L/3.0L(6229718 & later), All MC224 CID (6218037 & later), All GM 262 CID (A331455 & later) with Carter Fuel Pumps



18-7977
"GEN III COOL FUEL SYSTEM" FUEL FILTER
Replaces: 35-866171A01
For: 350 Mag MPI Alpha/Bravo, 350 Mag MPI Horizon Alpha/Bravo, 350 Mag MPI Horizon MIE, 350 Mag MPI MIE, 496 MAG, 496 MAG H.O., 5.0 MPI Alpha/Bravo, 8.1L Inboard, 8.1L Inboard H.O., MX 6.2L MPI Alpha/Bravo, MX 6.2L MPI Horizon Alpha/Bravo, MX 6.2L MPI Horizon MIE, MX 6.2L MPI MIE



18-7964-1
TRANSMISSION FILTER KIT
Replaces: 35-815419, 8791014241, 879194241, 35-813405A1, 35-813405, F19608751, FFF001138
For: Mercruiser V-8 Inboard with Hurth Transmission



18-7855
FUEL FILTER
Replaces: 1397-2150
For: Rochester Carb inlet



18-7717
FILTER ELEMENT
Replaces: 35-93568
For: Rochester 2 bbl & 4 bbl Carburetors



18-7859
FUEL FILTER
Replaces: 35-53336, 3302-9033, 35-53336Q
For: Most GM Inline 4 & 6 cycle, Ford & Gm V-8's up to 400 HP and all Mercruiser 224 CID



18-7721
FUEL FILTER
Replaces: 35-864572
For: All MPI & EFI engines with boost pump, 8.1L & 496cid, for 3/8" ID fuel lines



18-7860
FUEL FILTER
Replaces: 35-49088A2, 35-49088Q2, 35-49088, F18390006
(Used in 18-7278 Fuel Pump)
For: Inline 4 & 6 cycle engines



18-7869
FUEL FILTER ASSEMBLY
Uses filter 18-7859
Replaces: 1397-8767, 1397-8545
For:

Model/HP	Serial #
GM 2.5L/3.0L	6229718 & later
GM 5.0L/5.7L	6218462 & later
All 205	A331455 & later
228 HP	6021784 & later
330 HP	6083145 & later
GM 255	590768 & later
5.7L SKI 340,230 & 260 Inboards	ALL



18-7873
FUEL FILTER
Replaces: 35-808275
For: Models D7.3/270 Bravo & MIE Diesel Engines 1994-96



18-7715
FUEL FILTER
Replaces: 35-892665
Fits: Mercruiser V-8 using Gen III Cool Fuel Systems



18-79901
VST FILTER
Replaces: 65L-13915-00-00
Fits: 454 EFI(GenV) GM 1994-96, 454 EFI (SKI)(Gen V) GM 1995, 454 Mag Bravo MPI (Gen VI) GM 1996-97, 454 Mag MPI (SKI)(Gen VI) GM 1996-97, 502 EFI (Gen V) GM 1993-95, 502 Mag MPI (Gen VI) GM 1996, 7.4L MIE MPI (LH) Gen V GM 1995-96, 7.4L MIE MPI (LH) Gen VI GM 1996-97, 7.4LX Bravo MPI (Gen V) GM 1996, 7.4LX Bravo MPI (Gen VI) GM 1996-97, 8.2L MIE MPI (LH) Gen VI GM 1996-97



18-6457
COMPOSITE PULLEY
 Replaces: 807757T
 3" OD Serpentine for 13/16" width belt
 For: Late model GM V6 & V8 engines



18-3506
CIRCULATING PUMP
 Replaces: 46-879194401
 For: V6 MCM SN: 1A063240 (2007), Newer 4.3L w/o water bypass hole
 - CURRENT



18-3593
WATER PUMP
 Replaces: 33957, 37369, 52353, 65142, 65142A1, 814755, 880817, 884727, F2774666, FI1100785, FI1101079
 Late Model 4 cyl GM engines requiring hose fitting, GM Inline (4 & 6 Cyl.)



18-3577-2
CIRCULATING WATER PUMP (Bi-Directional)
 Replaces: 67859, 17670, 811573, 850454, 8504541, 878342, 850454002, 59972, 54534, 49139, F6269358, FI1100997, FI1101053
 For: Big block GM engines



18-3573
CIRCULATING WATER PUMP
 All 8.1L big-block GM engines
 Replaces: 883514, 883925
 For: Engines with composite timing cover



18-3584
CIRCULATING WATER PUMP
 Replaces: 71683A1, 883885, 71683, 58086, 56879
 Mercruiser 215 to 255 & 888
 For: Ford small block V-8 engines



18-3599-2
CIRCULATING WATER PUMP
 Replaces: 60658, 811841, 850399, 8503991, 17437, 878341, 850399002, 54793, 52226, 37951, 35341, FI1101292, FI1101208, FI1100742
 For: GM V-6 & small block V-8 engines



18-3007
18-3007-10^①
IMPELLER
 Replaces: 47-89983, 4789983T
 For 60 HP



18-3016-1
IMPELLER KIT
 with gasket
 Replaces: 47-862232A2, 8M0104229
 For: Late-model Bravo & High Performance. Includes 350 Mag., 4.3L., 496 Mag., 5.0L., 8.1S and MX 6.2L



18-3017
18-3017-10^①
IMPELLER
 Replaces: 47-89984, 47-899842, 47-89984T3, 47-89984T4, 47-899844, 47-30221, 47-65960, 47-85460
 For all #1, R, MR, Alpha Units thru S/N D494568.
 Also for raw water pump on: 190 IB S/N 1564539-1720903 225 IB S/N 1539620-2278646



18-3056
18-3056-10^①
IMPELLER
 Replaces: 47-43026-2
 For: Alpha I-Generation 2 S/N D494569 & Above
 Mercruiser Vazer



18-3087
IMPELLER
 Replaces: 47-59362, 47-59362T



18-3109
WATER TUBE GUIDE
 Replaces: 23-29804, 23-29804T, 23-52928
 (used with **18-3116** Housing)



18-3110
WATER PUMP HOUSING BUSHING
 Replaces: 26-38970, 26-36557A1, 26-29677
 (Part of **18-3116** Housing)



18-3114
INSERT CUP
 Replaces: 48752, 48752T
 (Part of **18-3116** Housing)

^① Discount shop pack of 10 - Priced per package

 <p>18-3117 IMPELLER PLATE Replaces: 32435, 324351, 30605 For: #1 Units thru S/N D494568</p>	 <p>18-3122 IMPELLER PLATE Replaces: 817276, 8172761, 8172763 For: Alpha I - Generation 2 S/N D494569 & Above</p>	 <p>18-3350 WEAR PLATE Replaces: 72778, 94576</p>		
 <p>18-3351 WEAR PLATE Replaces: 72777, 94916</p>	 <p>18-3293 IMPELLER KEY Replaces: 28-43037</p>	 <p>18-3151 COUPLING Replaces: 816597</p>		
 <p>18-3417 WATER PUMP BASE Replaces: 46-57234A1</p>	 <p>18-3420 WATER PUMP BASE Replaces: 46-44292A3, 46-44292Q03, 46-44292T1</p>	 <p>18-3421 WATER PUMP BASE Replaces: 46-48748A1</p>		
 <p>18-3116 WATER PUMP HOUSING Replaces: 46-96148, 46-96148A1, 46-96148T1, 46-64141A1, 46-48743A1</p>	<p>PKG. OF 2</p>  <p>6.125" 2.360"</p> <p>18-2732 18-2732-9^① WATER SHUTTER Replaces: 807166A3</p>	 <p>3.175" 2.5"</p> <p>18-2733 WATER SHUTTER Replaces: 92802, 99370A2</p>		
 <p>3.780" 3"</p> <p>18-2727 EXHAUST WATER SHUTTER Replaces: 60930</p>	 <p>18-3220 WATER TUBE Replaces: 32-54236 For: #1 -R/MR/Alpha</p>	 <p>18-3221 WATER TUBE Replaces: 32-814384, 32-860220 For: Gen II</p>		
 <p>18-3222 WATER TUBE GUIDE Replaces: 23-816583 For: Gen II</p>	<p>PKG. OF 5</p>  <p>18-3226 18-3226-9^① IMPELLER PUMP SCREW Replaces: 10-30720 For: R units</p>	<p>PKG. OF 5</p>  <p>18-3227 18-3227-9^① WATER PUMP DOWEL PIN Replaces: 17-35973 For: R/MR, Alpha I</p>	<p>PKG. OF 5</p>  <p>18-3229 18-3229-9^① WATER POCKET SCREW Replaces: 10-28668 For: MR/Alpha</p>	 <p>18-3197 SCREW Replaces: 10-76156, 10-67373</p>

① Priced per Package



18-3160-1
SEA WATER PUMP, BRASS
 Replaces: 46-862914A13
 Uses impeller **18-3016-1**



18-3600
SEA WATER PUMP
 Replaces: 46-72774A32, 46-72774A11, 46-73823A7, 46-63450A2, 46-59112A2
 Fits: V8 Engines with V-Belt and 2 piece pump
 Use repair kit **18-3155**



18-36001
SEA WATER PUMP
 Replaces: 46-807151A12
 Fits: V6 & V8 engines with v-belt and 1 piece pump
 Use repair kit **18-3237**



18-3155
WATER PUMP REPAIR KIT
 Replaces: 47-72774A89
 Fits: Bravo Seawater Pump with 2 piece housing



18-3216
IMPELLER KIT
 Replaces: 47-59362A4
 Fits: 1996-97 7.4L MIE MPI(LH) Gen VI GM 454 V8, 1996-97, 7.4L TBI MIE(LH) Gen VI GM 454 V8, 1996-97 8.2L MIE MPI(LH) Gen VI GM 502 V8



18-3318
WATER PUMP KIT
 Replaces: 47-59362Q08
 Fits: Plastic 1 and 2 piece sea water pump body



18-3237
IMPELLER REPAIR KIT
 For: Bravo I, II, III (1988 & up) B664190 & up
 Fits Bravo drives with 1 piece housing

—CONTAINS—			
Part #	Desc.	O.E. #	Qty.
18-3087	Impeller	47-59362	1
18-3350	Wear Plate	94576	1
18-7163	O-Ring	25-33465	1

18-3214
IMPELLER REPAIR KIT
 Replaces: 47-43026T6, T8, T11
 For: Alpha I - Generation II S/N D494569 & Above
 Mercuriser Vazer
 For same kit with upper housing, order **18-3147**

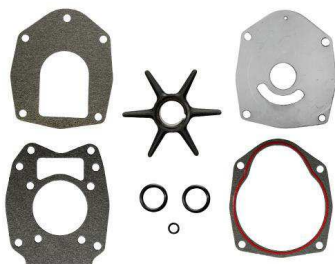

18-3214D

—CONTAINS—

Part #	Desc.	O.E. #	Qty.
18-2564	Impeller Gasket	22-43033-1, 27-43033-1	1
18-2565	Impeller Gasket	27-43047-1	1
18-2566	Impeller Gasket	27-817277	1
18-2944	Seal Ring	26-45577, 26-45577B, 26-45577B1	1
18-3056	Impeller	47-43026-1, 47-43026-2	1
18-3122	Impeller Plate	817276	1
18-7420	O-Ring	25-21836	2

18-3217
IMPELLER KIT
 For: #1 Units thru S/N D494568
 (Similar to #46-96148A5 without base or housing)



18-3217D

—CONTAINS—

Part #	Desc.	O.E. #	Qty.
18-3109	Water Tube	23-29804	1
18-3017	Impeller	47-89984	1
18-2919	Water Pump Base to Gear Housing Gasket	27-42631-1	1
18-3110	Grommet	26-38970	1
18-2945	Gear Housing Drain Screw Gasket	12-19183	2
18-2826	Water Pump Base to Gear Housing Gasket	27-85610-1	1
18-2914	Lower Water Pump to Wear Plate Gasket	27-85608-1	1
18-2915	Upper Water Pump to Wear Plate Gasket	27-85609-1	1
18-2944	Seal Ring	26-45577	1
18-3117	Plate	32435	1
18-7158	O-Ring	25-30613	1
18-7162	O-Ring	25-33145	1
18-7173	O-Ring	25-30224	1
18-7176	O-Ring	25-90011	1
18-2801	Water Pump Gasket	27-32438	1
18-7196	O-Ring	25-38099	1
18-7426	O-Ring	35-30271	1

18-3150
WATER PUMP KIT
 Replaces: 46-807151A14, 46-807151A7
 For: Bravo



18-3309
WATER PUMP KIT
 For: Bravo



18-3309D

—CONTAINS—

Part #	Desc.	O.E. #	Qty.
18-3350	Wear Plate	94576	1
18-3351	Wear Plate	94916	1
18-3087	Impeller	47-59362	1
18-0386	Body Gasket	27-94914	2
18-0916	Water Pump Gasket	27-805215-1	1

18-3147
WATER PUMP KIT
 Replaces: 817275T4, 817275K05
 For: Gen II-Lower s/n D469859 and Up
 For same kit without upper housing, order **18-3214**



① Items ending in "D" are Display Packaged - Regular number is Non-Display

—CONTAINS —

Part #	Desc.	O.E. #	Qty.
18-3109	Water Tube	23-29804	1
18-3017	Impeller	47-89984	1
18-3116	Housing	46-96148A1	1
18-2919	Water Pump Base to Gear Housing Gasket	27-42631-1	1
18-3110	Grommet	26-38970	1
18-2945	Gear Housing Drain Screw Gasket	26-20260, 12-19183	2
18-2826	Water Pump Base to Gear Housing Gasket	27-85610-1	1
18-2914	Lower Water Pump to Wear Plate Gasket	27-85608-1	1
18-2915	Upper Water Pump to Wear Plate Gasket	27-85609-1	1
18-2944	Seal Ring	26-45577	1
18-3117	Plate	32435	1
18-7158	O-Ring	25-30613	1
18-7162	O-Ring	25-33145	1
18-7173	O-Ring	25-30224	1
18-7176	O-Ring	25-90011	1
18-2801	Water Pump Gasket	27-32438	1
18-7196	O-Ring	25-38099	1
18-7426	O-Ring	35-30271	1



18-3517
WATER PUMP KIT
 Without Base
 Replaces: 46-96148A5,46-60367A1, 46-96148A8

—CONTAINS —

Part #	Desc.	O.E. #	Qty.
18-3109	Water Tube	23-29804	1
18-3017	Impeller	47-89984	1
18-3116	Housing	46-96148A1	1
18-3420	Water Pump Base	46-44292A3	1
18-2919	Water Pump Base to Gear Housing Gasket	27-42631-1	1
18-3110	Grommet	26-38970	1
18-2945	Gear Housing Drain Screw Gasket	12-19183	2
18-2826	Water Pump Base to Gear Housing Gasket	27-85610-1	1
18-2914	Lower Water Pump to Wear Plate Gasket	27-85608-1	1
18-2915	Upper Water Pump to Wear Plate Gasket	27-85609-1	1
18-2944	Seal Ring	26-45577	1
18-3117	Plate	32435	1
18-7158	O-Ring	25-30613	1
18-7162	O-Ring	25-33145	1
18-7173	O-Ring	25-30224	1
18-7176	O-Ring	25-90011	1
18-2801	Water Pump Gasket	27-32438	1
18-7196	O-Ring	25-38099	1
18-7426	O-Ring	35-30271	1



18-3320
WATER PUMP KIT
 For: MR/Alpha I Units
 S/N 6854393-OD469858

—CONTAINS —

Part #	Desc.	O.E. #	Qty.
18-3109	Water Tube	23-29804	1
18-3017	Impeller	47-89984	1
18-3116	Housing	46-96148A1	1
18-3421	Water Pump Base	46-48748A1	1
18-2919	Water Pump Base to Gear Housing Gasket	27-42631-1	1
18-3110	Grommet	26-38970	1
18-2945	Gear Housing Drain Screw Gasket	12-19183	2
18-2826	Water Pump Base to Gear Housing Gasket	27-85610-1	1
18-2914	Lower Water Pump to Wear Plate Gasket	27-85608-1	1
18-2915	Upper Water Pump to Wear Plate Gasket	27-85609-1	1
18-2944	Seal Ring	26-45577	1
18-3117	Plate	32435	1
18-7158	O-Ring	25-30613	1
18-7162	O-Ring	25-33145	1
18-7173	O-Ring	25-30224	1
18-7176	O-Ring	25-90011	1
18-2801	Water Pump Gasket	27-32438	1
18-7196	O-Ring	25-38099	1
18-7426	O-Ring	35-30271	1



18-3321
WATER PUMP KIT
 For: #1 Units with flush
 S/N 2495186-2763441

—CONTAINS —

Part #	Desc.	O.E. #	Qty.
18-3109	Water Tube	23-29804	1
18-3017	Impeller	47-89984	1
18-3116	Housing	46-96148A1	1
18-2919	Water Pump Base to Gear Housing Gasket	27-42631-1	1
18-3417	Water Pump Base	46-57234A1	1
18-3110	Grommet	26-38970	1
18-2945	Gear Housing Drain Screw Gasket	12-19183	2
18-2826	Water Pump Base to Gear Housing Gasket	27-85610-1	1
18-2914	Lower Water Pump to Wear Plate Gasket	27-85608-1	1
18-2915	Upper Water Pump to Wear Plate Gasket	27-85609-1	1
18-2944	Seal Ring	26-45577	1
18-3117	Plate	32435	1
18-7158	O-Ring	25-30613	1
18-7162	O-Ring	25-33145	1
18-7173	O-Ring	25-30224	1
18-7176	O-Ring	25-90011	1
18-2801	Water Pump Gasket	27-32438	1
18-7196	O-Ring	25-38099	1
18-7426	O-Ring	35-30271	1
18-2919	Water Pump Gasket	27-46231-1	1



18-3317
WATER PUMP KIT
 For: #1/R Units without flush
 S/N 2763442-6854392

COMPLETE WATER PUMP KIT, IMPELLER REPAIR KIT, IMPELLER APPLICATION

Model	Serial No.	Complete Water Pump Kit	Upper Pump Housing	Upper Pump Kit	Water Pump Base	Impeller Repair Kit (no housing)	Impeller
#1 Units with plastic flush screw in gear housing	2495186 - 2763441	18-3321	18-3116	18-3517	18-3421	18-3217	18-3017
#1 Units w/o flush screw in gear housing	2763442 - 6854392	18-3317 ①	18-3116	18-3517	18-3417 ①	18-3217	18-3017
MR/ALPHA I	6854393 - 0D594568	18-3320	18-3116	18-3517	18-3420	18-3217	18-3017
ALPHA I - Generation II & Vazer	0D494569 & ABOVE	18-3147	—	18-3570	—	18-3214	18-3056
BRAVO/Inboards w/ Plastic pump body	3040411 & ABOVE	—	—	18-3150	—	18-3318	18-3087
BRAVO/Inboards w/ Brass pump body	0M100001 & ABOVE	—	—	18-3160-1	—	18-3016-1	—

① Models which have been retro-fitted with an Alpha style lower unit (no pre-load pin in top of driveshaft) must use Alpha style parts (18-3320 and 18-3420)

GENERATION II WATER PUMP ASSEMBLY

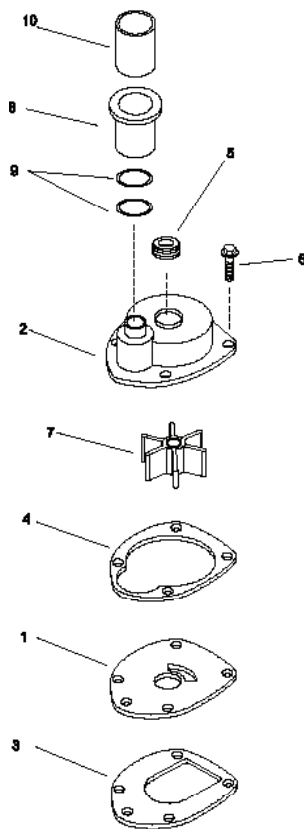

Sequence	Description	Part No.	O.E. #	Qty.
1	Face Plate	18-3122	817276	1
2	Housing Assembly	N.S.S.	817275A1	1
3	Gasket, Base	18-2564	27-43033-1	1
4	Gasket, Housing	18-2566	27-817277	1
5	Seal, Face	18-2599	26-816575A2	1
6	Screw, Housing	N/A	10-816928	4
7	Impeller	18-3056	47-43026-2	1
8	Coupling Assembly	18-3151	47-43026T11	1
9	O-Ring	18-7420	25-21836	2
10	Sleeve	18-3222	23-816583	1

MR ALPHA WATER PUMP ASSEMBLY

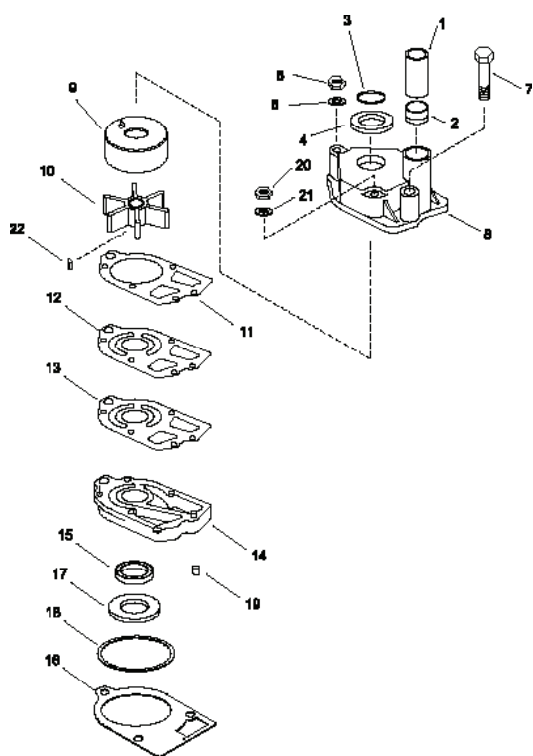

Sequence	Description	Part No.	O.E. #	Qty.
1	Guide Sleeve	18-3109	23-29804	1
2	Seal, Sleeve Guide	18-3110	26-38970	1
3	Ring, Upper	18-7158	25-30613	1
4	Ring, Dust	18-7426	25-30271	1
5	Nut, Housing	N/A	11-13436	1
6	Washer, Housing	18-4270	12-36001	3
7	Screw, Housing	N/A	10-96411	1
8	Housing, Water Pump	18-3116	46-96148A1	1
9	Cup, Impeller	18-3114	48752T	1
10	Impeller	18-3017	48752	1
11	Gasket, Impeller	18-2915	47-89984	1
12	Plate, Impeller	18-3117	27-85609-1	1
13	Gasket, Stainless Steel Plate	18-2914	27-85608-1	1
14	Water Pump Base Assembly	18-3420	46-44292A3	1
15	Oil Seal, Water Pump Base	18-2013	26-16977	1
16	Gasket, Water Pump Base	18-2919	27-42631-1	1
17	Oil Seal, Water Pump Base	18-2014	26-89238	1
18	O-Ring, Water Pump Base	18-7176	25-90011	1
19	Pin, Alignment	N/A	17-42836	1
20	Nut, Housing	N/A	11-13438	1
21	Washer, Housing	18-4275	12-29245	2
22	Key, Impeller	N/A	28-56654	1

R WATER PUMP ASSEMBLY

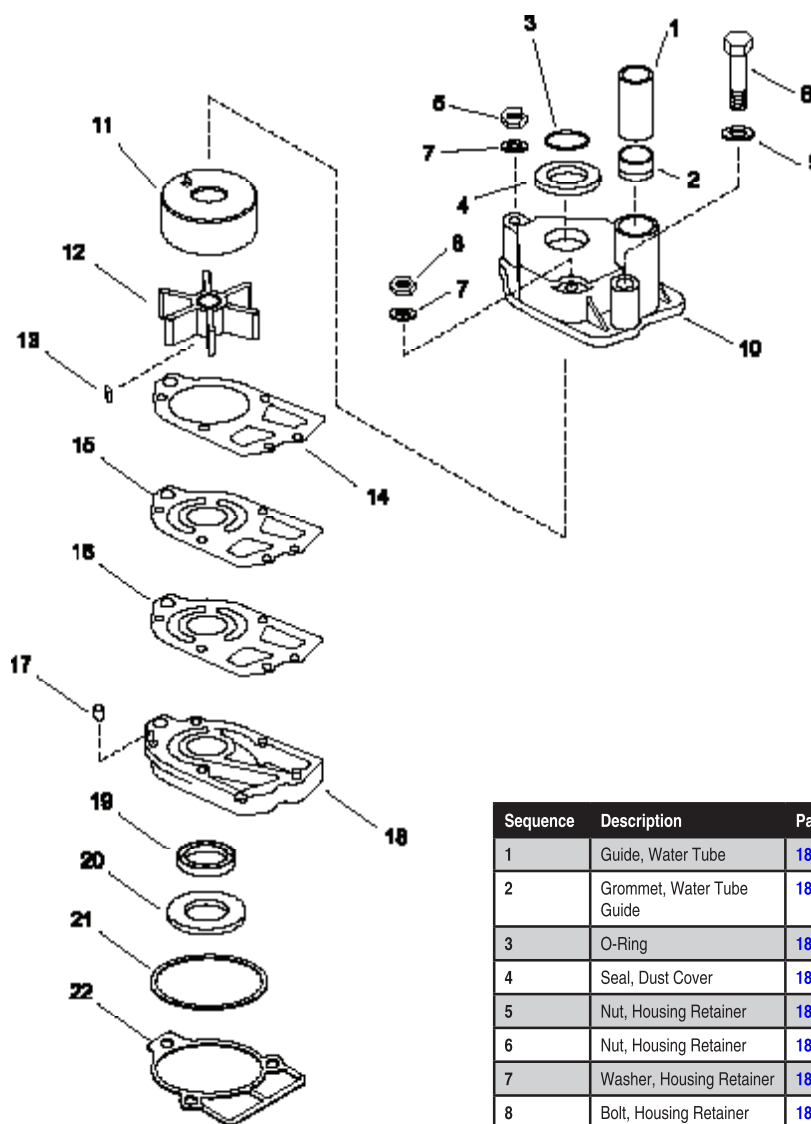

Sequence	Description	Part No.	O.E. #	Qty.
1	Guide, Water Tube	18-3109	23-29804	1
2	Grommet, Water Tube Guide	18-3110	26-38970	1
3	O-Ring	18-7158	25-30613	1
4	Seal, Dust Cover	18-7426	25-30271	1
5	Nut, Housing Retainer	18-3723	11-45592	1
6	Nut, Housing Retainer	18-3722	11-20361, 11-35888	2
7	Washer, Housing Retainer	18-4275	12-29245	3
8	Bolt, Housing Retainer	18-3226	10-30720	1
9	Washer, Housing Retainer	18-4270	12-36001	1
10	Housing, Impeller	18-3116	46-96148A1	1
11	Cup, Impeller	18-3114	48752	1
12	Impeller	18-3017	47-89984	1
13	Key, Impeller	N/A	28-56654	1
14	Gasket, Impeller	18-2915	27-85609-1	1
15	Wear Plate, Impeller	18-3117	32435	1
16	Gasket Wear Plate	18-2914	27-85608-1	1
17	Pin, Alignment	18-3227	17-35973	1
18	Base Assembly	18-3417	46-57234A1	1
19	Oil Seal, Base Assembly	18-2013	26-16977	1
20	Oil Seal, Base Assembly	18-2014	26-89238	1
21	O-Ring, Base Assembly	18-7162	25-33145	1
22	Gasket, Base Assembly	18-2826	27-85610-1	1



18-3549
THERMOSTAT
Replaces: 14586
120°



18-3550
THERMOSTAT
Replaces: 59078, 59078A1
140°



18-3551
THERMOSTAT
Replaces: 32728, 35884, 59137,
59137A1, 8072521, 8072531,
807252T1, 8M0089715
142°



18-3552
THERMOSTAT
Replaces: 76270, 76270T
160°



18-3555
THERMOSTAT
Replaces: 99155A1,
99155T2
160°



18-3557
THERMOSTAT
Replaces: 47594
143°



18-3649
THERMOSTAT
Replaces: 8072522, 807252T2,
8052732, 8M0091470
160°



18-43015
THERMOSTAT
Replaces: Mercury 864493
Fits: Mercruiser MCM 4.3L MPI, 5.0L
MPI and MX6.2L w/dry joint exhaust
and closed cooling



18-43017
THERMOSTAT
Replaces:
Mercury 863358T, 8M0074922, 8M0076464
Fits: Mercruiser 496 Mag & HO,
8.1L MIE & HO



18-3568
THERMOSTAT KIT
Replaces: 99155T1

Model	Year	Serial #
5.7MIE	1998-2001	OL002003 & Up
MX6.2LMPI	2000-2001	OL680003 & Up
454 Horizon MIE	1998-2001	OL002200 & Up
502 Mag. MPI	1998-2001	OL017000 & Up



18-3644
THERMOSTAT KIT
—CONTAINS—

Part #	Description	O.E.#
18-3649	Thermostat 160°	807252T2
18-2553	Thermostat Cover Gasket	27-47510
18-2917	Thermostat Cover Gasket	27-53045-1



18-3646
THERMOSTAT KIT
Replaces: 807252Q3, 807252T6
—CONTAINS—

Part #	Description	O.E.#
18-3551	Thermostat	59137
18-2917	Thermostat Housing Gasket	27-53045-1, 27-33918
18-2844	Thermostat Cover Gasket	27-48818-1
18-2553	Thermostat Cover Gasket	27-47510
18-2834	Thermostat Cover Gasket	27-60208



18-3647
THERMOSTAT KIT
Replaces: 807252Q5, 807252T8
—CONTAINS—

Part #	Description	O.E.#
18-3649	Thermostat	807252-2
18-2844	Thermostat Cover Gasket	27-48818-1
18-2553	Thermostat Cover Gasket	27-33179-2
18-2553	Thermostat Cover Gasket	27-47510
18-7173	O-Ring	25-30224
18-2917	Thermostat Housing Gasket	27-53045-1, 27-33918



18-3648
THERMOSTAT KIT
160°



18-3650
THERMOSTAT KIT
Replaces: 59078T3
—CONTAINS—

Part #	Description	O.E.#
18-2831	Thermostat Gasket	27-47590-1
18-3550	Thermostat	59078



18-3651
THERMOSTAT KIT
—CONTAINS—

Part #	Description	O.E.#
18-2554	Thermostat Cover Gasket	27-90556
18-2553	Thermostat Cover Gasket	27-47510
18-2834	Thermostat Cover Gasket	27-60208
18-2844	Thermostat Cover Gasket	27-48818-1
18-3551	Thermostat	59137



18-3652
THERMOSTAT KIT
—CONTAINS—

Part #	Description	O.E.#
18-2555	Thermostat Cover Gasket	27-89656-1
18-2843	Thermostat Cover Gasket	27-74830
18-3552	Thermostat	76270

THERMOSTAT APPLICATION BEGINS ON NEXT PAGE

① Items ending in "D" are Display Packaged - Regular number is Non-Display



18-3667
THERMOSTAT KIT
—CONTAINS—

Part #	Description	O.E.#
18-2555	Thermostat Cover Gasket	27-89656-1
18-3555	Thermostat	99155A1



18-3668
THERMOSTAT KIT
Replaces: 807252T4, 807252Q4
—CONTAINS—

Part #	Description	O.E.#
18-2552	Thermostat Cover Gasket	27-33179-2
18-2553	Thermostat Cover Gasket	27-47510
18-2554	Thermostat Cover Gasket	27-41812
18-3551	Thermostat	59137
18-7173	O-Ring	25-30224
18-2917	Thermostat Housing Gasket	27-53045-1, 27-33918



18-1977-1
THERMOSTAT HOUSING
Replaces: 47441, 47441A1
Fits: 225, GM 260, 228, 898/198, 185R, 898R, 228R, 2GR



18-1989
THERMOSTAT HOUSING
Replaces: 8M0061381, 861006A1
Stainless Steel
Use **18-1989K** Thermostat Service Kit for replacement parts



18-1993
THERMOSTAT HOUSING
Replaces: 78984A08, 78984A1, 78459A1, 59861A4, 59861A1



18-1994
THERMOSTAT HOUSING
Replaces: 87290A4
For: Stainless Steel Version use **18-1989**



18-3530-1
THERMOSTAT HOUSING
Replaces: 860256A4, 860256A2
For: GM V6 and V8 (305 & 350 ci)



18-3531
THERMOSTAT HOUSING
Replaces: 807074A1, 808064A1, 861188A1
Fits: MCM/MIE GM V-6 & V-8 (305, 350, 454 & 502 cid) engines w/closed cooling systems



18-1910
THERMOSTAT HOUSING KIT
Replaces: 47587, 47587A2, 47588, 60372A1, 60372A2, 63908A2, 861493A07, 861493A3
Fits: 3.0L GM 1999-Up, S/N 0L340999-Lower



18-1989K
THERMOSTAT SERVICE KIT
Service Kit for **18-1989** Thermostat Housing



18-1508
THERMOSTAT SEAL
Replaces: 25-8071341
Fits: Vazer (2007 & UP), GM V6 & V8 with closed cooling systems (1996 & UP)

THERMOSTAT APPLICATION

Engine/Model	CID#CYL	Year Range	Beginning Serial #	Ending Serial #	Housing	Thermostat Cover	Thermostat & Gasket Kit	Thermostat	Gaskets Req.	Gaskets Req. - Design II	Gaskets Req. - Design III
ROVER			3140000	UP				18-3551			
60	68/L4	1965-1968	1887079	2049044				18-3551			
80	80/L4	1966-1969	2049045	2851423				18-3551			
90	96/L4	1970-1972	2851424	3226957				18-3557	18-2831		
100 VASER	98/L4	2007-2010	w995000	& UP					18-1508		
110	153/L4	1963-1966	1537370	2044033	④			18-3551			
110	153/L4	1963-1966	1821720	2044033	⑤			18-3551			
120	153/L4	1964-1972	1666601	3377340	④			18-3551			
120	153/L4	1964-1966	1725593	2046624	⑤			18-3551			
120	153/L4	1967	2046625	2324346	⑤			18-3551			
120	153/L4	1968-1972	2324347	3377340	18-3650 ⑤, ③		18-3650	18-3550	18-2831		
120	153/L4	1972-1986	3377341	B531853	18-3650 ③		18-3650	18-3550	18-2831		
2.5L	153/L4	1987-1989	B531854	C853255	18-3650 ③		18-3650	18-3550	18-2831		
140	181/L4	1968-1986	2508261	B450800	18-3650 ③		18-3650	18-3550	18-2831		
140 (6 CYL)			1538930	1725960	—			18-3551	—		

- ① Design I
- ② Design II
- ③ Design III
- ④ Aluminum Exhaust Manifold
- ⑤ Cast Iron Exhaust Manifold
- ⑥ Closed Cooling
- ⑦ Standard Cooling
- ⑧ With check ball
- ⑨ Without check ball
- ⑩ SN 4167000 & Up
- ⑪ Original thermostat housing listed as NLA. Order update kit 87290A23
- ⑫ Original thermostat housing listed as NLA. Order update kit 90736A24
- ⑬ Complete thermostat housing kit kit
- ⑭ Single and 3-point drain system
- ⑮ 7-point drain system
- ⑯ Mechanical Throttle Body
- ⑰ Digital Throttle Body
- ⑱ Emission Control Engine
- ⑲ Manual drain system
- ⑳ Air Actuated drain system
- ㉑ Old Design
- ㉒ New Design
- ㉓ 160 degree
- ㉔ For Stainless Steel version use **18-1989**

THERMOSTAT APPLICATION (Cont.)

Engine/Model	CID/#CYL	Year Range	Beginning Serial #	Ending Serial #	Housing	Thermostat Cover	Thermostat & Gasket Kit	Thermostat	Gaskets Req.	Gaskets Req. - Design II	Gaskets Req. - Design III
3.0L	181/L4	1987-1989	B450801	C856558	18-3650 ③		18-3650	18-3550	18-2831		
3.0L, FWC	181/L4	1990-2010	C856559	UP	⑥		18-3647	18-3649			
3.0L	181/L4	1990-1994	C856559	F603999	18-3650 ⑦, ③		18-3650	18-3550	18-2831		
3.0L	181/L4	2000-2010	L341000	& UP	⑦		18-3647	18-3649	18-2552		
3.0L	181/L4	1998-2000	L010042	L340999	18-3650 ⑦, ③		18-3650	18-3550	18-2831		
3.0L MPI	181/L4	2008-2010	A072812	& UP			18-3647	18-3649	18-2552		
3.0L MPI FWC	181/L4	2008-2010	A072812	& UP	⑥		18-3647	18-3649			
3.0LX, FWC	181/L4	1990-1997	C856559	K999999	⑥		18-3647	18-3649			
3.0LX	181/L4	1990-1997	C856559	K999999	18-1910 ⑦, ③		18-3650	18-3550	18-2831		
150			1666495	2048046	—			18-3551	—		
160	①		2048022	2770031	—			18-3551	—		
160	②		2048022	2233574	—			18-3557	—		
160	②		2326069	2770031	—			18-3557	18-2831		
165			2770032	5813433	—		18-3650	18-3550	18-2831		
165	224/L4	1987	B434941	B774251			18-3667	18-3555	18-2555		
165			6916779	UP	—		18-3667	18-3555	18-2555		
170	224/L4	1985-1986	6916779	B434940	18-3667		18-3667	18-3555	18-2555		
175/4.3L, 4.3LX (262 CID)	③		B527955	UP	—		18-3668	18-3551	18-2553	18-2554	
175/4.3L, 4.3 LX (262 CID)	④		B527955	UP	—		18-3668	18-3551	18-2552	18-7173	
175/4.3L, 4.3 LX (262 CID)	④		F001220	UP	—		18-3648	18-3649 ♣	18-2552	18-7173	
180/3.7L-LX (4 CYL)			6916779	UP	—		18-3667	18-3555	18-2555		
180	224/L4	1987	B436391	B775248			18-3667	18-3555	18-2555		
185 (229 CID)			6330183	6919655	18-1994 ♥		18-3668	18-3551	18-2553	18-2554	
185 (262 CID)			A331455	B527954	18-1994 ♥		18-3668	18-3551	18-2553	18-2554	
190			1564539	1730903	—			18-3551	—	—	
190	224/L4	1985-1986	6916779	B436390			18-3667	18-3555	18-2555		
3.7L	224/L4	1988-1989	B774552	& UP			18-3667	18-3555	18-2555		
3.7LX	224/L4	1988-1989	B775249	& UP			18-3667	18-3555	18-2555		
470 MCMME	224/L4	1976-1982	4208730	6218036				18-3552	18-2843		
470	224/L4	1983-1984	6218037	6916778			18-3667	18-3555	18-2555		
485	224/L4	1980-1982	5685394	6218036				18-3552	18-2555		
488	224/L4	1983-1984	6170297	6916778			18-3667	18-3555	18-2555		
140 (6 CYL)	194/L6	1963	1538930	1725960				18-3551			
150	230/L6	1964-1966	1666495	2048046	④			18-3551			
150	230/L6	1964-1966	1727985	2048046	⑤			18-3551			
160	250/L6	1967-1969	2048022	2770031	④			18-3551			
160	250/L6	1967	2048022	2233574	⑤			18-3551			
160	250/L6	1968-1969	2326096	2770031	18-1910 ⑥, ③			18-3557	18-2831		
165 (6 CYL)	250/L6	1970-1981	2770032	5813433	18-1910 ③		18-3650	18-3550	18-2831		
200 (6 CYL)	292/L6	1969	2453769	2712072	18-1910 ③			18-3557	18-2831		
185 (4bbl)	229-V-6	1983-1984	6330183	6919655	18-3678		18-3668	18-3551	18-2554	18-2553	18-2917
175	262/V-6	1987	B527955	B773242	18-1994 ①	18-1977-1	18-3668	18-3551	18-2554	18-2553	18-2917
175	262/V-6	1987	B527955	B773242	②, ⑥		18-3668	18-3551	18-7173		18-2917
185 (2bbl)	262/V-6	1985-1986	A331455	B527954	18-1994	18-1977-1	18-3668	18-3551	18-2554	18-2553	18-2917
205	262/V-6	1985-1986	A331455	B527954	18-3668	18-1977-1	18-3668	18-3551	18-2554	18-2553	18-2917
205	262/V-6	1987	B527955	B775129	18-3668 ①	18-1977-1	18-3668	18-3551	18-2554		18-2917
205	262/V-6	1967	B527955	B775129	②, ⑥		18-3668	18-3551	18-7173	18-2552	18-2917
205/4.3L, 4.3 LX (262 CID)	④		B527955	D714369	— ⑦		18-3668	18-3551	18-2552	18-7173	
205/4.3L, 4.3 LX (262 CID)	④		F001220	UP	—		18-3648	18-3649 ♣	18-2552	18-7173	

- ① Design I
- ② Design II
- ③ Design III
- ④ Aluminum Exhaust Manifold
- ⑤ Cast Iron Exhaust Manifold
- ⑥ Closed Cooling
- ⑦ Standard Cooling
- ⑧ With check ball

- ⑨ Without check ball
- ⑩ SN 4167000 & Up
- ⑪ Original thermostat housing listed as NLA. Order update kit 87290A23
- ⑫ Original thermostat housing listed as NLA. Order update kit 90736A24
- ⑬ Complete thermostat housing kit kit
- ⑭ Single and 3-point drain system
- ⑮ 7-point drain system
- ⑯ Mechanical Throttle Body

- ⑰ Digital Throttle Body
- ⑱ Emission Control Engine
- ⑲ Manual drain system
- ⑳ Air Actuated drain system
- ㉑ Old Design
- ㉒ New Design
- ♣ 160 degree
- ♥ For Stainless Steel version use 18-1989

THERMOSTAT APPLICATION (Cont.)

Engine/Model	CID#CYL	Year Range	Beginning Serial #	Ending Serial #	Housing	Thermostat Cover	Thermostat & Gasket Kit	Thermostat	Gaskets Req.	Gaskets Req. - Design II	Gaskets Req. - Design III
215 FORD			2781153	3040410	—			18-3551	—	—	
215 FORD			3040411	UP	—		18-3651	18-3551	18-2834	—	
215 FORD MCMME			3040411	3385720	—		18-3646	18-3649 ♣	18-2834	—	
225 FORD MCMME			3385721	4176999	—		18-3646	18-3649 ♣	18-2834	—	
262 MAG EFI ALPHA	262V-6	1996-1997	0F803800	0K999999	18-3647		18-3647	18-3649	18-2917		
262 MAG EFI BRAVO	262V-6	1996-1997	0F803800	0K999999	18-3647		18-3647	18-3649	18-2917		
4.3L	262V-6	1988-1993	B773243	F000877	18-1994 ①	18-1977-1	18-3668	18-3551	18-2554	18-2553	18-2917
4.3L	262V-6	1987-1993	B773243	F000877	②, ③		18-3668	18-3551	18-7173	18-2552	18-2917
4.3L	262V-6	1993-1995	F000878	F601126	18-3647 ②, ③		18-3668	18-3649	18-2917	18-2552	18-2917
4.3L	262V-6	1993-1995	F000878	F601126	③		18-3668	18-3551	18-0398		
4.3L FWC	262V-6	1993-2002	F000878	M614999	18-3531 ⑥		18-3568	18-3555	18-0398		
4.3L ALPHA	262V-6	1996-2002	0F601127	M614999	18-3647 ⑦		18-3647	18-3649	18-2917		
4.3L BRAVO	262V-6	2996-2002	0F601127	M614999	18-3647 ⑦		18-3647	18-3649	18-2917		
4.3L FWC	262V-6	2002-2010	M615000	& UP	⑧				18-0398		
4.3L	262V-6	2002-2010	M615000	& UP	⑦		18-3647	18-3649	18-0398		
4.3L EFI FWC	262V-6	1998-2001	L012009	M299999	18-3531 ⑧		18-3568	18-3555	18-0398		
4.3L EFI ALPHA	262V-6	1998-2001	L012009	M299999	⑦		18-3647	18-3649	18-0398		
4.3L EFI BRAVO	262V-6	1998-2001	L012009	M299999	18-3530-1 ⑦		18-3647	18-3649	18-0398		
4.3L MPI	262V-6	2002-2010	M300000	& UP	⑦, ④		18-3647	18-3649	18-0398		
4.3L MPI	262V-6	2002-2010	M300000	& UP	⑦, ⑤		18-3647	18-3649	18-0398		
4.3L MPI EC	262V-6	2010-2011	A637496	& UP	⑦, ⑧		18-3647	18-3649	18-0398		
4.3L MPI FWC	262V-6	2002	M300000	M614999	⑧		18-3568	18-3555	18-0398		
4.3L MPI FWC	262V-6	2002-2010	M615000	& UP	⑧				18-0398		
4.3LH FWC	262V-6	1998-2002	L010044	M614999	18-3531 ⑧		18-3568	18-3555	18-0398		
4.3LH ALPHA	262V-6	1998-2002	L010044	M614999	⑦		18-3647	18-3649	18-0398		
4.3LH BRAVO	262V-6	1998-2002	L010044	M614999	18-3530-1 ⑦		18-3647	18-3649	18-0398		
4.3LX	262V-6	1988-1993	B775130	F001219	18-1994 ①	18-1977-1	18-3668	18-3551	18-2554	18-2553	18-2917
4.3LX	262V-6	1988-1993	B775130	F001219	②, ⑤		18-3668	18-3551	18-7173	18-2552	18-2917
4.3LX	262V-6	1993-1995	F001220	F601126	②, ③		18-3668	18-3551	18-7173	18-2552	18-2917
4.3LX	262V-6	1993-1995	F001220	F601126	③		18-3668	18-3551	18-0398		
4.3LX FWC	262V-6	1993-1997	F001220	K999999	⑧		18-3567	18-3555	18-0398		
4.3LX ALPHA	262V-6	1996-1997	F601127	K999999	⑦		18-3647	18-3649	18-0398		
4.3LX BRAVO	262V-6	1996-1997	F601127	K999999	18-3530-1 ⑦		18-3647	18-3649	18-0398		
4.3LXH FWC	262V-6	1996-1997	F803114	K999999	18-3531 ⑧		18-3568	18-3555	18-0398		
4.3LXH ALPHA	262V-6	1996-1997	F803114	K999999	18-3530-1 ⑦		18-3647	18-3649	18-0398		
4.3LXH BRAVO	262V-6	1996-1997	F803114	K999999	18-3530-1 ⑦		18-3647	18-3649	18-0398		
215 MCMME (FORD)	302V-8	1970	2781153	3040410				18-3649			
215 MCMME (FORD)	302V-8	1971-1972	3040411	3385720			18-3646	18-3551	18-2834		
225 MCMME (FORD)	302V-8	1973-1974	3385721	4176999			18-3646	18-3551	18-2834		
888 (FORD)	302V-8	1971-1977	3108723	4887829	⑩		18-3646	18-3551	18-2834		
190	263V-8	1963-1964	1564539	1730903				18-3551			
198 MIE	305V-8	1977	4762210	6218461	18-1993						
198 MIE	305V-8	1977	4776402	4931099		18-1977-1	18-3646	18-3551	18-2844	18-0398	
200	305V-8	1985-1987	6899058	B774444	18-1994	18-1977-1	18-3668	18-3551	18-2554	18-2553	18-2917
200 GM			6218462	B525981	18-1994 ♥		18-3668	18-3551	18-2553	18-2554	
200/5.0L			0B525982	0F600999			18-3647	18-3649 ♣	18-2917	—	
200/5.0L GM	③		B525982	UP	18-1994 ♥		18-3668	18-3551	18-2553	18-2554	
200/5.0L GM	④		B525982	UP	18-1994 ♥		18-3648	18-3649 □	18-2552	18-7173	
228	305V-8	1977-1982	4765100	6218461	18-1993	18-1977-1	18-3646	18-3551	18-2844	18-0398	

- ① Design I
- ② Design II
- ③ Design III
- ④ Aluminum Exhaust Manifold
- ⑤ Cast Iron Exhaust Manifold
- ⑥ Closed Cooling
- ⑦ Standard Cooling
- ⑧ With check ball

- ⑨ Without check ball
- ⑩ SN 4167000 & Up
- ① Original thermostat housing listed as NLA. Order update kit 87290A23
- ② Original thermostat housing listed as NLA. Order update kit 90736A24
- ③ Complete thermostat housing kit kit
- ④ Single and 3-point drain system
- ⑤ 7-point drain system
- ⑥ Mechanical Throttle Body

- ⑦ Digital Throttle Body
- ⑧ Emission Control Engine
- ⑨ Manual drain system
- ⑩ Air Actuated drain system
- ♣ Old Design
- ♣ New Design
- ♣ 160 degree
- ♥ For Stainless Steel version use 18-1989

THERMOSTAT APPLICATION (Cont.)

Engine/Model	CID#CYL	Year Range	Beginning Serial #	Ending Serial #	Housing	Thermostat Cover	Thermostat & Gasket Kit	Thermostat	Gaskets Req.	Gaskets Req. - Design II	Gaskets Req. - Design III
228	305V-8	1982-1984	6218462	6899268	18-1994	18-1977-1	18-3668	18-3551	18-2554	18-2553	18-2917
228 MIE	305V-8	1977-1980	4765100	5907057	18-3651, 18-1993	18-1977-1	18-3646	18-3551	18-2844	18-1993	
230	305V-8	1985-1987	6899269	B773739	18-1994	18-1977-1	18-3668	18-3551	18-2554	18-2553	18-2917
230 MIE	305V-8	1981-1987	5907058	B788151	18-1994 ⑦	18-1977-1	18-3668	18-3551	18-2554	18-2553	18-2917
230 MIE FWC	305V-8	1981-1987	5907058	B788151	⑥	18-1977-1	18-3646	18-3551	18-2553	18-2844	18-2917
230 GM			6218462	B525981	18-1994 ♥		18-3668	18-3551	18-2553	18-2554	
230 MIE			5907058	0B5225505			18-3646	18-3649 □	18-2553	18-2844	18-2917
230 GM IB	⑤		5907058	B522505	⑦		18-3668	18-3551	18-2553	18-2554	
230 GM IB	⑥		5907058	B522505	⑥		18-3651	18-3551	18-2553	18-2844	
230/5.0L GM IB	③ ⑤		B522506	B525981	EST, ⑦		18-3668	18-3551	18-2553	18-2554	18-2917
230/5.0L GM IB	④ ⑤		B522506	B525981	▲, ⑦		18-3648	18-3649 □	18-2552	18-7173	18-2917
230/5.0L GM IB	⑥		B522506	B525981			18-3651	18-3551	18-2553	18-2844	18-2917
230/5.0L-LX GM	③		B525982	F600999	18-1994 ♥		18-3668	18-3551	18-2553	18-2554	
230/5.0L-LX GM	④		B525982	UP			18-3668	18-3551	18-2552	18-7173	
230/5.0L GM IB	④		B522506	B525981			18-3648	18-3649 □	18-2552	18-7173	
230/5.0L-LX GM			B525982	F600999	18-1994 ♥		18-3648	18-3649 □	18-2552	18-7173	
230/5.0L MIE			0B522506	0B788151			18-3646	18-3649 □	18-2553	18-2844	18-2917
230/5.0LX GM			0B525982	0F600999			18-3647	18-3649 □	18-2917	—	
5.0L	305V-8	1988-1995	B774445	F600999	18-1994 ①	18-1977-1	18-3668	18-3551	18-2554	18-2553	
5.0L	305V-8	1988-1995	B774445	F600999	②, ⑤		18-3668	18-3551	18-7173	18-2552	
5.0L	305V-8	1988-1995	B774445	F600999	②, ⑤		18-3668	18-3551	18-7173	18-2552	
5.0L	305V-8	1988-1995	B774445	F600999	③		18-3647	18-3649	18-0398		18-2917
5.0L (GEN+) FWC	305V-8	1998-2002	L015751	M599999	18-3531 ⑥		18-3668	18-3555	18-1508		18-2917
5.0L (GEN+) FWC	305V-8	2002-2010	M600000	& UP	⑥				18-0398		18-2917
5.0L (GEN+) ALPHA	305V-8	1998-2002	L015751	M599999	⑦		18-3647	18-3649	18-0398		
5.0L (GEN+) BRAVO	305V-8	1998-2002	L015751	M599999	18-3530-1 ⑦		18-3647	18-3649	18-0398		
5.0L (GEN+) BRAVO	305V-8	2002-2010	M600000	& UP	⑦		18-3647	18-3649	18-0398		
5.0L EFI FWC	305V-8	1998-2001	L012052	M299999	18-3531 ⑥		18-3668	18-3555	18-1508		
5.0L EFI ALPHA	305V-8	1998-2001	L012052	M299999	⑦		18-3647	18-3649	18-0398		
5.0L EFI BRAVO	305V-8	1998-2001	L012052	M299999	18-3530-1 ⑦		18-3647	18-3649	18-0398		
5.0L MIE FWC	305V-8	1988	B788152	C396832	⑥	18-1977-1	18-3646	18-3551	18-2553	18-2844	
5.0L MIE	305V-8	1988	B788152	C396832	⑦, ⑧, ①		18-3668	18-3551	18-7173		
5.0L MIE	305V-8	1988	B788152	C396832	18-1994 ①, ⑦	18-1977-1	18-3668	18-3551	18-2554	18-2553	
5.0L MPI FWC	305V-8	2002	M300000	M599999	⑥		18-3668	18-3555	18-0398		
5.0L MPI FWC	305V-8	2002-2010	M600000	& UP	⑥				18-0398		18-2917
5.0L MPI FWC DTS	305V-8	2005-2010	W310000	& UP	⑥, ⑦				18-0398		18-2917
5.0L MPI FWC EC	305V-8	2008-2010	A300000	& UP	⑥, ⑦, ⑧				18-0398		
5.0L MPI FWC EC DTS	305V-8	2008-2010	A300000	& UP	⑥, ⑦, ⑧				18-0398		
5.0L MPI	305V-8	2002-2010	M300000	& UP	⑦, ④		18-3647	18-3649	18-0398		18-2917
5.0L MPI ALPHA	305V-8	2002	M300000	M599999	⑦, ⑤		18-3647	18-3649	18-0398		
5.0L MPI BRAVO	305V-8	2002	M300000	M599999	18-3530-1 ⑦, ⑤		18-3647	18-3649	18-0398		
5.0L MPI	305V-8	2002-2010	M600000	& UP	⑦, ⑤		18-3647	18-3649	18-0398		
5.0L MPI EC	305V-8	2008-2010	A300000	& UP	⑦, ⑧		18-3647	18-3649	18-0398		
5.0L LX	305V-8	1988-1995	B773740	F600999	18-1994 ①	18-1977-1	18-3668	18-3551	18-2554	18-2553	18-2917
5.0LX	305V-8	1988-1995	B773740	F600999	②, ⑤		18-3668	18-3551	18-7173	18-2552	
5.0LX	305V-8	1988-1995	B773740	F600999	⑤		18-3647	18-3649	18-0398		
898	305V-8	1977-1982	4762210	6218461		18-1977-1	18-3646	18-3551	18-2844	18-0398	
898	305V-8	1983-1984	6218462	6899057	18-1994	18-1977-1	18-3668	18-3551	18-2554	18-2553	

- ① Design I
- ② Design II
- ③ Design III
- ④ Aluminum Exhaust Manifold
- ⑤ Cast Iron Exhaust Manifold
- ⑥ Closed Cooling
- ⑦ Standard Cooling
- ⑧ With check ball

- ⑨ Without check ball
- ⑩ SN 4167000 & Up
- ⑪ Original thermostat housing listed as NLA. Order update kit 87290A23
- ⑫ Original thermostat housing listed as NLA. Order update kit 90736A24
- ⑬ Complete thermostat housing kit kit
- ⑭ Single and 3-point drain system
- ⑮ 7-point drain system
- ⑯ Mechanical Throttle Body

- ⑰ Digital Throttle Body
- ⑱ Emission Control Engine
- ⑲ Manual drain system
- ⑳ Air Actuated drain system
- ㉑ Old Design
- ㉒ New Design
- ㉓ 160 degree
- ♥ For Stainless Steel version use 18-1989

THERMOSTAT APPLICATION (Cont.)

Engine/Model	CID#CYL	Year Range	Beginning Serial #	Ending Serial #	Housing	Thermostat Cover	Thermostat & Gasket Kit	Thermostat	Gaskets Req.	Gaskets Req. - Design II	Gaskets Req. - Design III
225 (GM)	327/V-8	1967-1969	2399198	2694014		18-1977-1	18-3651	18-3551	18-2553	18-2844	
225 (GM)	327/V-8	1963-1967	1539620	2399197	N.L.A.			18-3551			
225 (GM)			2278647	2399197			18-3668	18-3551	18-2552	18-7173	
225/225S FORD			3385721	UP			18-3651	18-3551	18-2834		
250 MCMME	327/V-8	1968-1969	2314301	2639854		18-1977-1	18-3651	18-3551	18-2553	18-2844	
250	350/V-8	1977	4768000	4908849	18-1993	18-1977-1	18-3651	18-3551	18-2844		
250 (GM)			4768000	4908849			18-3646	18-3551	18-2844		
250 (GM)			4175500	5907057	18-1993		18-3651	18-3649	18-2844	18-2917	
255 (GM)	350/V-8	1975-1976	4175500	4767999		18-1977-1	18-3646	18-3551	18-2844	18-0398	
255 (GM) MIE	350/V-8	1975-1980	4175500	5907057		18-1977-1	18-3646	18-3551	18-2844	18-0398	
255 (GM) MIE	350/V-8	1979-1980	5195909	5907057	18-1993						
255 FORD			3258728	UP			18-3651	18-3551	18-2834	—	
255 FORD MCMME			3258728	4178299			18-3646	18-3649	18-2834	—	
260	350/V-8	1978-1982	4908850	6218461	18-1993	18-1977-1	18-3651	18-3551	18-2844	18-0398	
260	350/V-8	1982-1987	6218462	B773304	18-1994	18-1977-1	18-3668	18-3551	18-2554	18-2553	18-2917
260 MIE FWC	350/V-8	1981-1987	5907058	B788151	⑤	18-1977-1	18-3646	18-3551	18-2553	18-2844	18-2917
260 MIE	350/V-8	1981-1987	5907058	B788151	18-1994 ⑦	18-1977-1	18-3668	18-3551	18-2554	18-2553	18-2917
260 GM			6218462	B525981	18-1994 ♥		18-3668	18-3551	18-2553	18-2554	
260 GM			4908850	6218461			18-3646	18-3649	18-2844	18-2917	
260 GM IB	⑤		5907058	B522505	⑦		18-3668	18-3551	18-2553	18-2554	
260 GM IB	⑥		5907058	B522505	⑥		18-3651	18-3551	18-2553	18-2844	
260 MIE			5907058	0B522505			18-3646	18-3649	18-2553	18-2844	18-2917
260/5.7L GM IB	③ ⑤		B522506	B525981	⑦		18-3668	18-3551	18-2553	18-2554	
260/5.7L GM IB	④ ⑤		B522506	B525981	♣ ⑦		18-3668	18-3551	18-2552	18-7173	
260/5.7L GM IB	④ ⑤		B522506	B525981	♣ ⑦		18-3648	18-3649 ♣	18-2552	18-7173	
260/5.7L GM IB	⑥		B522506	B525981	⑥		18-3651	18-3551	18-2553	18-2844	
260/5.7L GM	③		B525982	F600999	18-1994 ♥		18-3668	18-3551 ⑧	18-2553	18-2554	
260/5.7L GM	④		B525982	F600999			18-3668	18-3551 ♣	18-2552	18-7173	
260/5.7L GM	④		B525982	F600999			18-3648	18-3649 ♣	18-2552	18-7173	
260/5.7L GM			0B525982	0F600999			18-3647	18-3649	18-2917	—	
260/5.7L MIE			0B522506	0F024999			18-3646	18-3649	18-2553	18-2844	18-2917
270 MCMME	350/V-8	1969-1972	2851074	3385720		18-1977-1	18-3646	18-3551	18-2553	18-2844	18-2917
270 GM			2851074	3077735			18-3651	18-3551	18-2553	18-2844	
280 GM	350/V-8	1975-1976	4176250	4770199		18-1977-1	18-3646	18-3649	18-2844	18-0398	
280 GM TRS			4176250	4770199	18-1993		18-3651	18-3551	18-2844		
300	350/V-8	1985-1986	6668677	B430367		18-1977-1	18-3668	18-3551	18-2554	18-2553	18-2917
320 EFI	350/V-8	1987-1989	A543604	C622418		18-1977-1	18-3646	18-3551	18-2553	18-2844	18-2917
325 GM MCMME			2278747	3780449			18-3646	18-3649	18-2553	18-2844	18-2917
325 GM			2278747	2313964			18-3668	18-3551	18-2553	—	
325 GM			2313965	3042730			18-3651	18-3551	18-2553	18-2844	
325 GM			3042731	UP			18-3651	18-3551	18-2844	—	
330 GM			4623115	UP			18-3651	18-3551	18-2844	—	
330 GM MCMME			4623115	0B816540			18-3646	18-3649	18-2553	18-2844	18-2917
330 GM W/BW	⑤		6083145	UP	⑦		18-3668	18-3551	18-2553	18-2554	
330 GM W/BW	⑥		6083145	UP	⑥		18-3651	18-3551	18-2553	18-2844	
350 MAG ALPHA	350/V-8	1987-1995	B525982	F600999	②, ③		18-3668	18-3551	18-7173		18-2917
350 MAG ALPHA	350/V-8	1986-1995	A635178	B525981	①	18-1977-1	18-3668	18-3551	18-2554	18-2553	18-2917
350 MAG ALPHA	350/V-8	1987-1995	B525982	F600999	②, ③		18-3668	18-3551	18-7173	18-2552	18-2917
350 MAG ALPHA	350/V-8	1987-1997	B525982	K999999	③		18-3647	18-3649	18-0398		

- ① Design I
- ② Design II
- ③ Design III
- ♣ Aluminum Exhaust Manifold
- ⑤ Cast Iron Exhaust Manifold
- ⑦ Closed Cooling
- ⑦ Standard Cooling
- ⑧ With check ball

- ⑥ Without check ball
- ⑥ SN 4167000 & Up
- ① Original thermostat housing listed as NLA. Order update kit 87290A23
- ② Original thermostat housing listed as NLA. Order update kit 90736A24
- ③ Complete thermostat housing kit
- ④ Single and 3-point drain system
- ⑤ 7-point drain system
- ⑥ Mechanical Throttle Body

- ⑦ Digital Throttle Body
- ⑧ Emission Control Engine
- ⑨ Manual drain system
- ⑩ Air Actuated drain system
- ⑧ Old Design
- ♣ New Design
- ♣ 160 degree
- ♥ For Stainless Steel version use 18-1989

THERMOSTAT APPLICATION (Cont.)

Engine/Model	CID#CYL	Year Range	Beginning Serial #	Ending Serial #	Housing	Thermostat Cover	Thermostat & Gasket Kit	Thermostat	Gaskets Req.	Gaskets Req. - Design II	Gaskets Req. - Design III
350 MAG ALPHA EFI (GEN+)	350V-8	1996-1997	F800300	K999999			18-3647	18-3649	18-0398		
350 MAG BRAVO MPI	350V-8	1995-1997	F415189	K999999	18-3530-1		18-3647	18-3649	18-0398		
350 MAG EFI SKI	350V-8	1994-1997	F215561	K999999	18-3530-1		18-3647	18-3649	18-0398		
350 MAG MPI FWC	350V-8	1998-2001	L010019	M299999	18-3531 ⑥		18-3568	18-3555	18-1508		
350 MAG MPI	350V-8	1998-2001	L010019	M299999	18-3530-1 ⑦		18-3647	18-3649	18-0398		
350 MAG MPI FWC	350V-8	2002	M300000	M599999	⑥		18-3568	18-3555	18-0398		
350 MAG MPI FWC	350V-8	2002-2010	M600000	& UP	⑤				18-0398		
350 MAG MPI FWC DTS	350V-8	2005-2010	W310000	& UP	⑥, ⑦				18-0398		
350 MAG MPI FWC EC	350V-8	2008-2010	A300000	& UP	⑥, ⑥, ⑧				18-0398		
350 MAG MPI FWC EC DTS	350V-8	2008-2010	A300000	& UP	⑥, ⑦, ⑧		N/A		18-0398		
350 MAG MPI	350V-8	2002	M300000	M599999	⑦, ④		18-3647	18-3649	18-0398		
350 MAG MPI ALPHA	350V-8	2002	M300000	M599999	⑦, ⑤		18-3647	18-3649	18-0398		
350 MAG MPI BRAVO	350V-8	2002	M300000	M599999	18-3530-1 ⑦, ⑤		18-3647	18-3649	18-0398		
350 MAG MPI	350V-8	2002-2010	M600000	& UP	⑦, ⑤		18-3647	18-3649	18-0398		
350 MAG MPI	350V-8	2002-2010	M600000	& UP	⑦, ④		18-3647	18-3649	18-0398		
350 MAG MPI EC	350V-8	2008-2010	A300000	& UP	⑦, ⑧		18-3647	18-3649	18-0398		
350 MAG MPI HORIZON	350V-8	2002	M300000	M599999	⑥		18-3568	18-3555	18-0398		
350 MAG MPI HORIZON	350V-8	2002-2007	M600000	A299999	⑥				18-0398		
350 MAG MPI HORIZON MIE	350V-8	1999-2001	L304700	M299999	18-3531 ⑥		18-3568	18-3555	18-1508		
350 MAG MPI HORIZON MIE	350V-8	2002	M300000	M316999	⑥		18-3568	18-3555	18-1508		
350 MAG MPI HORIZON MIE	350V-8	2002-2007	M317000	A089999	⑥				18-0398		
350 MAG MPI MIE FWC	350V-8	1998-2001	L002008	M299999	18-3531 ⑥		18-3568	18-3555	18-1508		
350 MPI MIE	350V-8	1998-2001	L002008	M299999	18-3530-1 ⑦		18-3647	18-3649	18-0398		
350 MAG MPI MIE FWC	350V-8	2002	M300000	M316999	⑥		18-3568	18-3555	18-1508		
350 MAG MPI MIE FWC	350V-8	2002-2007	M317000	A089999	⑥				18-0398		
350 MAG MPI MIE	350V-8	2002-2007	M300000	A089999	⑦		18-3647	18-3649	18-0398		
350 MAG MPI SKI	350V-8	1995-2001	F350583	M299999	18-3530-1		18-3647	18-3649	18-0398		
350 MAG MPI SKI	350V-8	2002-2007	M300000	A089999			18-3647	18-3649	18-0398		
350 MAG SKI	350V-8	1991-1996	D505450	K040399	②, ③		18-3668	18-3551	18-7173	18-2552	18-2917
350 MAG SKI	350V-8	1991-1997	D505450	K999999	18-3530-1 ③		18-3647	18-3649	18-0398		
5.7L	350V-8	1988-1995	B773305	F600999	18-1994 ①	18-1977-1	18-3668	18-3551	18-2554	18-2553	18-2917
5.7L	350V-8	1988-1995	B773305	F600999	②, ③		18-3668	18-3551	18-7173	18-2552	18-2917
5.7L	350V-8	1988-1995	B773305	F600999	②, ③		18-3668	18-3551	18-7173	18-2552	18-2917
5.7L	350V-8	1988-1996	B773305	K001526	③		18-3647	18-3649	18-2844	18-0398	
5.7L FWC	350V-8	1997	K001527	K999999	18-3531 ⑥		18-3568	18-3555	18-1508		
5.7L ALPHA	350V-8	1988-1997	B773305	F600999	⑦		18-3647	18-3649	18-0398		
5.7L BRAVO	350V-8	1995-1997	F601000	K999999	18-3530-1 ⑦		18-3647	18-3649	18-0398		
5.7L (GEN+) FWC	350V-8	1998-2002	L010037	M599999	18-3531 ⑥		18-3568	18-3555	18-1508		
5.7L (GEN+) ALPHA	350V-8	1998-2002	L010037	M599999	⑦		18-3647	18-3649	18-0398		
5.7L (GEN+) BRAVO	350V-8	1998-2002	L010037	M599999	18-3530-1 ⑦		18-3647	18-3649	18-0398		
5.7L (GEN+) FWC	350V-8	2002-2010	M600000	& UP	⑥				18-0398		
5.7L (GEN+)	350V-8	2002-2010	M600000	& UP	⑦		18-3647	18-3649	18-0398		
5.7L EFI FWC	350V-8	1995-1996	F225560	K001505	⑥		18-3647	18-3649	18-2844	18-0398	

- ① Design I
- ② Design II
- ③ Design III
- ④ Aluminum Exhaust Manifold
- ⑤ Cast Iron Exhaust Manifold
- ⑥ Closed Cooling
- ⑦ Standard Cooling
- ⑧ With check ball

- ⑨ Without check ball
- ⑩ SN 4167000 & Up
- ⑪ Original thermostat housing listed as NLA. Order update kit 87290A23
- ⑫ Original thermostat housing listed as NLA. Order update kit 90736A24
- ⑬ Complete thermostat housing kit kit
- ⑭ Single and 3-point drain system
- ⑮ 7-point drain system
- ⑯ Mechanical Throttle Body

- ⑰ Digital Throttle Body
- ⑱ Emission Control Engine
- ⑲ Manual drain system
- ⑳ Air Actuated drain system
- ㉑ Old Design
- ㉒ New Design
- ㉓ 160 degree
- ㉔ For Stainless Steel version use 18-1989

THERMOSTAT APPLICATION (Cont.)

Engine/Model	CID#CYL	Year Range	Beginning Serial #	Ending Serial #	Housing	Thermostat Cover	Thermostat & Gasket Kit	Thermostat	Gaskets Req.	Gaskets Req. - Design II	Gaskets Req. - Design III
5.7L EFI FWC	350V-8	1997-2001	K001506	M299999	18-3531 ⑥		18-3568	18-3555	18-1508		
5.7L EFI ALPHA	350V-8	1995-2001	F355305	M299999	⑦		18-3647	18-3649	18-0398		
5.7L EFI BRAVO	350V-8	1995-2001	F225560	M299999	18-3530-1 ⑦		18-3647	18-3649	18-0398		
5.7L EFI MIE (GEN +) FWC	350V-8	1997	K040300	K999999	18-3531 ⑥		18-3568	18-3555	18-1508		
5.7L EFI MIE (GEN +)	350V-8	1997	K040300	K999999	18-3530-1 ⑦		18-3647	18-3649	18-0398		
5.7L MIE	350V-8	1988-1995	B788152	F600999	18-1994 ①	18-1977-1	18-3668	18-3551	18-2554	18-2553	18-2917
5.7L MIE	350V-8	1988-1995	B788152	F622099	⑦, ⑧		18-3668	18-3551	18-7173		18-2917
5.7L MIE	350V-8	1988-1995	B788152	F622099	⑦, ⑧		18-3668	18-3555	18-7173		18-2917
5.7L MIE FWC	350V-8	1988-1996	B788152	K04306	⑥		18-3647	18-3649	18-2844		
5.7L MIE FWC	350V-8	1997-2002	K040307	M316999	18-3531 ⑥		18-3568	18-3555	18-1508		
5.7L MIE	350V-8	1996-2002	F622100	M316999	⑦		18-3647	18-3649	18-0398		
5.7L MIE FWC	350V-8	2002-2010	M317000	& UP	⑥				18-0398		
5.7L MIE	350V-8	2002-2010	M317000	& UP	⑦		18-3647	18-3649	18-0398		
5.7L MPI HORIZON MIE	350V-8	2008-2010	A0900000	& UP	⑥				18-0398		
5.7L MPI MIE FWC	350V-8	2008-2010	A0900000	& UP	⑥				18-0398		
5.7L MPI MIE FWC DTS	350V-8	2008-2010	A0900000	& UP	⑥, ⑦				18-0398		
5.7L MPI MIE FWC EC	350V-8	2008-2010	A0900000	& UP	⑥, ⑥, ⑥				18-0398		
5.7L MPI MIE FWC EC DTS	350V-8	2008-2010	A0900000	& UP	⑦, ⑦, ⑧				18-0398		
5.7L MPI MIE	350V-8	2008-2010	A0900000	& UP	⑦		18-3647	18-3649	18-0398		
5.7L MPI MIE EC	350V-8	2008-2010	A0900000	& UP	⑦, ⑧		18-3647	18-3649	18-0398		
5.7L MPI SKI	350V-8	2008-2010	A0900000	& UP			18-3647	18-3649	18-0398		
5.7L MPI SKI EC	350V-8	2008-2010	A0900000	& UP	⑧		18-3647	18-3649	18-0398		
5.7L SKI	350V-8	1985-1995	A338553	F775199	18-1994 ①	18-1977-1	18-3668	18-3551	18-2554	18-2553	18-0398
5.7L SKI	350V-8	1987-1995	B514627	F775199	②, ③		18-3668	18-3551	18-7173		18-0398
5.7L SKI	350V-8	1987-1995	B514627	F775199	②, ④		18-3668	18-3551	18-7173		18-0398
5.7L SKI	350V-8	1996-2002	F775200	M316999	18-3530-1 ③		18-3647	18-3649	18-0398		
5.7L SKI	350V-8	2002-2010	M317000	& UP	⑦		18-3647	18-3649	18-0398		
5.7LX ALPHA	350V-8	1995-1997	F601000	K999999	⑦		18-3647	18-3649	18-0398		
5.7LX BRAVO	350V-8	1995-1997	F601000	K999999	18-3530-1 ⑦		18-3647	18-3649	18-0398		
5.7LX RWC	350V-8	1996	F601000	K001526	⑥		18-3647	18-3649	18-2844	18-0398	
5.7LX RWC	350V-8	1997	K001527	K999999	18-3531 ⑥		18-3568	18-3555	18-1508		
5.7LX BRAVO EFI (GEN +) FWC	350V-8	1996	F800300	K001508	⑥		18-3647	18-3649	18-2844	18-0398	
5.7LX BRAVO EFI (GEN +) FWC	350V-8	1997	K001509	K999999	⑥		18-3568	18-3555	18-0398		
5.7LX BRAVO EFI (GEN +)	350V-8	1996-1997	F800300	K999999	18-3530-1 ⑦		18-3647	18-3649	18-0398		
5.7LX EFI FWC	350V-8	1996	F752400	K001505	⑥		18-3647	18-3649	18-2844	18-0398	
5.7LX EFI FWC	350V-8	1997	K001506	K999999	18-3531 ⑥		18-3568	18-3555	18-0398		
5.7LX EFI ALPHA	350V-8	1996-1997	F752400	K999999	⑦		18-3647	18-3649	18-0398		
5.7LX EFI BRAVO	350V-8	1996-1997	F752400	K999999	18-3530-1 ⑦		18-3647	18-3649	18-0398		
5.7 GM ALPHA			F225560	OK999999			18-3647	18-3649	18-2917	—	
5.7 GM BRAVO			F225560	OK999999			18-3647	18-3649	18-2917	—	
5.7L/EFI GM ALPHA			L010037	UP			18-3647	18-3649	18-2917	—	
5.7L/EFI GM BRAVO			L010037	UP			18-3647	18-3649	18-2917	—	
5.7L MIE			F025000	0F622099			18-3647	18-3649	18-2844	—	
5.7L MIE			F622100	OK999999			18-3647	18-3649	18-2917	—	
5.7L MIE			F622100	OK999999			18-3647	18-3649	18-2844	—	
5.7L MIE			L002003	UP			18-3647	18-3649	18-2917	—	

- ① Design I
- ② Design II
- ③ Design III
- ④ Aluminum Exhaust Manifold
- ⑤ Cast Iron Exhaust Manifold
- ⑥ Closed Cooling
- ⑦ Standard Cooling
- ⑧ With check ball

- ⑨ Without check ball
- ⑩ SN 4167000 & Up
- ⑪ Original thermostat housing listed as NLA. Order update kit 87290A23
- ⑫ Original thermostat housing listed as NLA. Order update kit 90736A24
- ⑬ Complete thermostat housing kit kit
- ⑭ Single and 3-point drain system
- ⑮ 7-point drain system
- ⑯ Mechanical Throttle Body

- ⑰ Digital Throttle Body
- ⑱ Emission Control Engine
- ⑲ Manual drain system
- ⑳ Air Actuated drain system
- ㉑ Old Design
- ㉒ New Design
- ㉓ 160 degree
- ㉔ For Stainless Steel version use 18-1989

THERMOSTAT APPLICATION (Cont.)

Engine/Model	CID#CYL	Year Range	Beginning Serial #	Ending Serial #	Housing	Thermostat Cover	Thermostat & Gasket Kit	Thermostat	Gaskets Req.	Gaskets Req. - Design II	Gaskets Req. - Design III
BLACK SCORPION SKI	350V-8	1996-2001	0F800000	M391599	18-3530-1		18-3647	18-3649	18-0398		
BLACK SCORPION SKI	350V-8	2003-2006	M391600	W690192	⑨		18-3647	18-3649	18-0398		
BLACK SCORPION SKI	350V-8	2006-2007	W690193	W698432	⑨		18-3647	18-3649	18-0398		
BLACK SCORPION SKI	350V-8	2003-2007	M391600	W698433	⑩		18-3647	18-3649	18-0398		
SCORPION 350	350V-8	2008-2010	W698433	& UP	⑨		18-3647	18-3649	18-0398		
SCORPION 350	350V-8	2008-2010	W698433	& UP	⑩		18-3647	18-3649	18-0398		
SCORPION 350 EC	350V-8	2008-2010	W698433	& UP	⑥		18-3647	18-3649	18-0398		
233 MCM (FORD)	351V-8	1975-1977	4173000	4902304			18-3646	18-3551	18-2834		
233 MIE (FORD)	351V-8	1975-1977	4173000	4902304			18-3646	18-3551	18-2834		
255 MCM/MIE (FORD)	351V-8	1973-1974	3258728	4178299			18-3646	18-3551	18-2834		
377 MAG FWC	377V-8	2008-2010	A300000	& UP	③, ⑥				18-0398		
377 MAG FWC DTS	377V-8	2008-2010	A300000	& UP	③, ⑦				18-0398		
377 MAG FWC EC	377V-8	2008-2010	A300000	& UP	③, ⑥				18-0398		
377 MAG FWC EC DTS	377V-8	2008-2010	A300000	& UP	③, ⑦, ⑧				18-0398		
377 MAG	377V-8	2008-2010	A300000	& UP	⑦, ④		18-3647	18-3649	18-0398		
377 MAG	377V-8	2008-2010	A300000	& UP	⑦, ⑤		18-3647	18-3649	18-0398		
377 MAG EC	377V-8	2008-2010	A300000	& UP	⑦, ⑥		18-3647	18-3649	18-0398		
377 SCORPION MCM	377V-8	1999-2005	L416146	M907201		18-1977-1		18-3551	18-0398		18-2553
377 SCORPION SKI	377V-8	1997-1998	K000656	L600314			18-3647	18-3649	18-0398		
MX 6.2L MPI FWC	377V-8	2000-2001	L680003	M299999	18-3531 ⑥		18-3568	18-3555	18-0398		
MX 6.2L MPI	377V-8	2000-2001	L680003	M299999	18-3530-1 ⑦		18-3647	18-3649	18-0398		
MX 6.2L MPI FWC	377V-8	2002	M300000	M599999	③		18-3568	18-3555	18-0398		
MX 6.2L MPI FWC	377V-8	2002-2007	M600000	A299999	③				18-0398		
MX 6.2L MPI	377V-8	2002-2007	M300000	A299999	⑦, ④		18-3647	18-3649	18-0398		
MX 6.2L MPI	377V-8	2002-2007	M300000	A299999	⑦, ⑤		18-3647	18-3649	18-0398		
MX 6.2L MPI HORIZON	377V-8	2002	M300000	M599999	③		18-3568	18-3555	18-0398		
MX 6.2L MPI HORIZON	377V-8	2002-2007	M600000	A299999	③				18-0398		
MX 6.2L MPI HORIZON MIE	377V-8	2002	M300000	M316999	③		18-3568	18-3555	18-0398		
MX 6.2L MPI HORIZON MIE	377V-8	2002-2010	M317000	& UP	③				18-0398		
MX 6.2L MPI MIE FWC	377V-8	1999-2002	L670000	M316999	③		18-3568	18-3555	18-0398		
MX 6.2L MPI MIE FWC	377V-8	2002-2010	M317000	& UP	③, ⑥				18-0398		
MX 6.2L MPI MIE FWC DTS	377V-8	2008-2010	A0900000	& UP	③, ⑦				18-0398		
MX 6.2L MPI MIE FWC EC	377V-8	2008-2010	A0900000	& UP	③, ⑥, ⑧				18-0398		
MX 6.2L MPI MIE FWC EC DTS	377V-8	2008-2010	A0900000	& UP	③, ⑦, ⑧				18-0398		
MX 6.2L MPI MIE	377V-8	2002-2010	M300000	& UP	⑦		18-3647	18-3649	18-0398		
MX 6.2L MPI MIE	377V-8	2008-2010	A0900000	& UP	⑦		18-3647	18-3649	18-0398		
MX 6.2L BLACK SCORPION	377V-8	2001-2002	L005601	M391599	18-3530-1		18-3647	18-3649	18-0398		
MX 6.2L BLACK SCORPION	377V-8	2003-2006	M391600	W690192	⑨		18-3647	18-3649	18-0398		
MX 6.2L BLACK SCORPION	377V-8	2006-2007	W690192	W698432	⑨		18-3647	18-3649	18-0398		
SCORPION 377	377V-8	2008-2010	W698433	& UP	⑨		18-3647	18-3649	18-0398		
SCORPION 377	377V-8	2008-2010	W698433	& UP	⑩		18-3647	18-3649	18-0398		
SCORPION 377 HO EC	377V-8	2008-2010	A091488	A092170	⑥		18-3647	18-3649	18-0398		
325 MCM/MIE	427V-8	1969-1972	2278747	3780449			18-3646	18-3551	18-2553		18-0398

- ① Design I
- ② Design II
- ③ Design III
- ④ Aluminum Exhaust Manifold
- ⑤ Cast Iron Exhaust Manifold
- ⑥ Closed Cooling
- ⑦ Standard Cooling
- ⑧ With check ball

- ⑨ Without check ball
- ⑩ SN 4167000 & Up
- ① Original thermostat housing listed as NLA. Order update kit 87290A23
- ② Original thermostat housing listed as NLA. Order update kit 90736A24
- ③ Complete thermostat housing kit kit
- ④ Single and 3-point drain system
- ⑤ 7-point drain system
- ⑥ Mechanical Throttle Body

- ⑦ Digital Throttle Body
- ⑧ Emission Control Engine
- ⑨ Manual drain system
- ⑩ Air Actuated drain system
- Ⓜ Old Design
- ♣ New Design
- ♠ 160 degree
- ♥ For Stainless Steel version use 18-1989

THERMOSTAT APPLICATION (Cont.)

Engine/Model	CID#CYL	Year Range	Beginning Serial #	Ending Serial #	Housing	Thermostat Cover	Thermostat & Gasket Kit	Thermostat	Gaskets Req.	Gaskets Req. - Design II	Gaskets Req. - Design III
330 (WITH MERC TRANS)	454V-8	1977-1981	4623115	6083144			18-3646	18-3551	18-2844	18-0398	
330 (WITH BW) FWC	454V-8	1982-1987	6083145	B816540	①		18-3646	18-3551	18-2553		18-0398
330 (WITH BW)	454V-8	1982-1987	6083145	B816540	18-3678 ⑦		18-3668	18-3551	18-2554	18-2553	18-0398
330 MIE (WITH MERC TRANS)	454V-8	1977-1980	4623115	5889913			18-3646	18-3551	18-2844	18-0398	
340 MIE FWC	454V-8	1981-1987	5889914	B788365	③		18-3646	18-3551	18-2553	18-2844	18-0398
340 MIE	454V-8	1981-1987	5889914	B788365	18-3678 ⑦		18-3668	18-3551	18-2554	18-2844	18-0398
340 MIE	454V-8	1981-1987	5889914	B788365	⑦, ⑧		18-3668	18-3551	18-2554	18-2553	18-0398
340/7.4L MIE			5889914	0D715493			18-3646	18-3649	18-2553	18-2844	18-2917
350 MIE	454V-8	1974-1976	3780450	4623109			18-3646	18-3551	18-2844	18-0398	
350 GM (MAGNUM)			A635178	B525981			18-3668	18-3551	18-2553	18-2554	
350 GM (MAGNUM)	□		B525982	UP	⊞		18-3668	18-3551	18-2553	18-2554	
350 GM (MAGNUM)	□		B525982	UP	▲		18-3668	18-3551	18-2552	18-7173	
350 GM (MAGNUM)	□		B525982	UP	18-3648 ▲		18-3648	18-3649 □	18-2552	18-7173	
370	454V-8	1978-1985	4179554	6721527		18-1977-1	18-3646	18-3551	18-2553	18-2844	18-0398
370	454V-8	1985-1987	6721528	B714586			18-3668	18-3551	18-2554	18-2553	18-0398
370 TRS GM			4179554	6721527			18-3651	18-3551	18-2553	18-2844	
370 TRS GM			6721528	UP			18-3668	18-3551	18-2553	18-2554	
390 GM			2781129	2825059			18-3651	18-3551	18-2553	18-2844	
390 GM MCMME			2781129	3042731			18-3646	18-3649	18-2553	18-2844	18-2917
400	454V-8	1980-1986	4179554	0B457644			18-3646	18-3551	18-2553	18-2554	18-0398
400 TRS GM			4179554	UP			18-3651	18-3551	18-2553	18-2844	
420 GM			A398941	UP	18-3651		18-3651	18-3551	18-2553	18-2844	
420	454V-8	1987-1989	A398941	B622418	18-1994	18-1977-1	18-3646	18-3551	18-2553	18-2844	18-0398
425	454V-8	1990-1993	A398941	D937011	18-3678			18-3551		18-2553	18-0398
440	454V-8	1983-1986	4179554	B485220			18-3646	18-3551	18-2553	18-2844	18-0398
450	454V-8	1995-1996	F347100	F347277	18-1994	18-1977-1		18-3551		18-2553	18-0398
525 SC	454V-8	1991-1999	D456000	L415623		18-1977-1		18-3551		18-2553	18-0398
454 MAG ALPHA	454V-8	1986-1988	A631894	B785148	18-3678 ①		18-3668	18-3551	18-2554	18-2553	18-0398
454 MAG ALPHA	454V-8	1986-1988	A631894	B785148	②, ③		18-3668	18-3551	18-7173	18-2552	18-0398
454 MAG BRAVO	454V-8	1988-1992	B721206	D805068	18-3678 ①		18-3668	18-3551	18-2554	18-2553	18-0398
454 MAG BRAVO	454V-8	1995-1997	F305000	K999999	②, ③		18-3647	18-3649	18-0398		
454 MAG BRAVO	454V-8	1988-1992	B721206	D805068	②, ③		18-3668	18-3551	18-7173		18-0398
454 MAG BRAVO	454V-8	1992-1994	D805069	F304999	②, ③		18-3668	18-3551	18-7173		18-0398
454 MAG EFI	454V-8	1995-1997	F115700	F802349	⑦		18-3647	18-3649	18-0398		
454 MAG EFI SKI	454V-8	1995-1997	F215800	K999999	⑦		18-3647	18-3649	18-0398		
454 MAG MPI	454V-8	1996-2001	F802350	M024999	⑦		18-3647	18-3649	18-0398		
454 MAG MPI FWC	454V-8	1998-2001	L010029	M024999	18-3531 ⑤		18-3568	18-3555	18-0398		
454 MAG MPI HORIZON MIE	454V-8	1998-2001	L002200	L674000	18-3531 ⑤		18-3568	18-3555	18-0398		
454 MAG MPI SKI	454V-8	1996-1997	F820100	K999999	⑦		18-3647	18-3649	18-0398		
525 SC	454V-8	1991-1999	D456000	L415623		18-1977-1		18-3551		18-2553	18-0398
7.4L BRAVO	454V-8	1995-1997	0F352000	0K999999	⑦		18-3647	18-3649	18-0398		
7.4L BRAVO	454V-8	1988-1991	B771113	D603117	18-3678 ①		18-3668	18-3551	18-2554	18-2553	18-0398
7.4L BRAVO	454V-8	1988-1991	B771113	D603117	②, ③		18-3668	18-3551	18-7173	18-2552	18-0398
7.4L BRAVO	454V-8	1992-1994	D603118	F351999	②, ③		18-3668	18-3551	18-7173	18-2552	18-0398
7.4L EFI MIE	454V-8	1996-1997	F874815	K999999	⑦		18-3647	18-3649	18-0398		
7.4L EFI MIE FWC	454V-8	1996-1997	F874815	K999999	18-3531 ⑤		18-3568	18-3555	18-0398		
7.4L MIE FWC	454V-8	1988-1992	B788366	D715493	③		18-3646	18-3551	18-2553	18-2844	18-0398

- ① Design I
- ② Design II
- ③ Design III
- ④ Aluminum Exhaust Manifold
- ⑤ Cast Iron Exhaust Manifold
- ⑥ Closed Cooling
- ⑦ Standard Cooling
- ⑧ With check ball

- ⑨ Without check ball
- ⑩ SN 4167000 & Up
- ⑪ Original thermostat housing listed as NLA. Order update kit 87290A23
- ⑫ Original thermostat housing listed as NLA. Order update kit 90736A24
- ⑬ Complete thermostat housing kit
- ⑭ Single and 3-point drain system
- ⑮ 7-point drain system
- ⑯ Mechanical Throttle Body

- ⑰ Digital Throttle Body
- ⑱ Emission Control Engine
- ⑲ Manual drain system
- ⑳ Air Actuated drain system
- ⊞ Old Design
- ▲ New Design
- ♣ 160 degree
- ♥ For Stainless Steel version use 18-1989

THERMOSTAT APPLICATION (Cont.)

Engine/Model	CID#CYL	Year Range	Beginning Serial #	Ending Serial #	Housing	Thermostat Cover	Thermostat & Gasket Kit	Thermostat	Gaskets Req.	Gaskets Req. - Design II	Gaskets Req. - Design III
7.4L MIE	454/V-8	1988-1992	B788366	D715493	⑦, ⑧		18-3668	18-3551	18-2554	18-2553	18-0398
7.4L MIE	454/V-8	1989-1994	C391564	D715493	⑦		18-3668	18-3551	18-7173	18-2552	18-0398
7.4L MIE FWC	454/V-8	1989-1994	C391564	D715493	⑥		18-3646	18-3551	18-2553	18-2844	18-0398
7.4L MIE	454/V-8	1989-1994	D715494	F349999	⑦		18-3668	18-3551	18-7173	18-2552	18-0398
7.4L MIE FWC	454/V-8	1989-1994	D715494	F820141	⑥		18-3646	18-3649	18-2553	18-2844	18-0398
7.4L MIE	454/V-8	1995-1996	F350000	F820141	⑦		18-3647	18-3649	18-0398		
7.4L MIE	454/V-8	1996-1997	F820142	K999999	⑦		18-3647	18-3649	18-0398		
7.4L MIE	454/V-8	1996-1997	F820142	K999999	⑥		18-3647	18-3649	18-2844	18-0398	
7.4L MPI	454/V-8	1998-2001	L010003	M024330	⑦		18-3647	18-3649	18-0398		
7.4L MPI MIE	454/V-8	1995-2001	F563052	M025999	⑦		18-3647	18-3649	18-0398		
7.4L MPI MIE FWC	454/V-8	1995-2001	F563052	M025999	⑥		18-3568	18-3555	18-0398		
7.4LX BRAVO EFI	454/V-8	1996-1997	F820000	K999999	⑦		18-3647	18-3649	18-0398		
7.4L BRAVO MPI	454/V-8	1996-1997	F602010	K999999	⑦		18-3647	18-3649	18-0398		
7.4L MIE			0C391564	0D715493			18-3646	18-3649	18-2553	18-2844	18-2917
7.4L MIE			0C391564	0F349999			18-3646	18-3649	18-2553	18-2844	18-2917
390 MCMME	482/V-8	1969-1970	2781129	3042731			18-3646	18-3551	18-2553	18-2844	18-0398
460	482/V-8	1983-1986	4179554	6181046			18-3668	18-3551	18-2554	18-2553	18-0398
465	502/V-8	1990-1994	C849992	F213244	18-3678			18-3551		18-2553	18-0398
470			4208730	6218036			18-3652	18-3552	18-2843		
470			6218037	UP			18-3667	18-3555	18-2555	—	
485			5685394	UP			18-3652	18-3552	18-2555	—	
488			6170297	UP			18-3667	18-3555	18-2555	—	
500	502/V-8	1994-1998	F213293	L001772	18-1994	18-1977-1		18-3551		18-2553	18-0398
500 (GEN +)	502/V-8	1999	L414639	L601036	18-1994	18-1977-1		18-3551		18-2553	18-0398
500 EFI	502/V-8	1999-2005	L001477	M907127		18-1977-1		18-3551		18-2553	18-0398
502 MAG	502/V-8	1990-1993	C878221	F114528	⑥		18-3668	18-3551	18-7173	18-2552	18-0398
502 MAG EFI	502/V-8	1993-1995	D840650	F802599	⑦		18-3647	18-3649	18-0398		
502 MAG MPI	502/V-8	1996-1997	F802600	K999999	⑦		18-3647	18-3649	18-0398		
502 MAG MPI FWC	502/V-8	1998-2001	L017000	M024999	18-3531 ⑥		18-3568	18-3555	18-0398		
525 EFI	502/V-8	2003-2010	M900146	& UP			N/A		18-1508		
575 GM			0A677429	0D763716			18-3646	18-3649	18-2553	18-2844	18-2914
575			A677429	UP			18-3651	18-3551	18-2553	18-2844	
8.2L MAG	502/V-8	2010	A350340	& UP					18-1508		
8.2L MIE EC	502/V-8	2010	A350802	& UP					18-1508		
8.2L MIE	502/V-8	1990-1992	C878221	D857199	⑦		18-3668	18-3551	18-7173	18-2552	18-0398
8.2L MIE FWC	502/V-8	1990-1992	C878221	D857199	⑥		18-3668	18-3551	18-2553	18-2844	18-0398
8.2L MIE	502/V-8	1993-1996	D857200	F350274	⑦		18-3647	18-3649	18-0398		
8.2L MIE	502/V-8	1996	F350275	F819619	⑦		18-3647	18-3649	18-0398		
8.2L MIE FWC	502/V-8	1993-1996	D857200	F819619	⑥		18-3647	18-3649	18-2844	18-0398	
8.2L MPI MIE	502/V-8	1996-2001	F819620	L674200	⑦		18-3647	18-3649	18-0398		
8.2L MPI MIE FWC	502/V-8	1996-2001	F819620	L674200	18-3531 ⑥		18-3568	18-3555	18-1508		
500 BULLDOG	540/V-8	1990-2001	C577254	M050281	18-1994	18-1977-1		18-3551		18-2553	18-0398
888 FORD			3108723	UP			18-3651	18-3551	18-2834		
888 FORD MCM			3108723	4887829			18-3646	18-3649	18-2834		
898/198 GM			4762210	6218461			18-3651	18-3551	18-2844		
898/198 GM MCMME			4762210	6218461			18-3646	18-3649	18-2844	18-2917	
898 GM		1977-1982	4762210	6218461	18-1993						
898 GM			6218462	UP			18-3668	18-3551	18-2553	18-2554	

- ① Design I
- ② Design II
- ③ Design III
- ④ Aluminum Exhaust Manifold
- ⑤ Cast Iron Exhaust Manifold
- ⑥ Closed Cooling
- ⑦ Standard Cooling
- ⑧ With check ball

- ⑨ Without check ball
- ⑩ SN 4167000 & Up
- ⑪ Original thermostat housing listed as NLA. Order update kit 87290A23
- ⑫ Original thermostat housing listed as NLA. Order update kit 90736A24
- ⑬ Complete thermostat housing kit kit
- ⑭ Single and 3-point drain system
- ⑮ 7-point drain system
- ⑯ Mechanical Throttle Body

- ⑰ Digital Throttle Body
- ⑱ Emission Control Engine
- ⑲ Manual drain system
- ⑳ Air Actuated drain system
- Ⓜ Old Design
- ♣ New Design
- ♣ 160 degree
- ♥ For Stainless Steel version use 18-1989



18-7702
AIR CHARGE
TEMPERATURE SENDER
Replaces: 805223T
Fits: Mercruiser V6 & V8(350, 454, 496 & 502 cid)MPI engines



18-5897
SENDER
Replaces: 97257A1, 806490T, 97257, 806490, 811091, 36525
For Water Temperature
 3/8" - 18 NPT



18-5898
SENDER
Replaces: 97258A1, 97258, 34625, F16900198, F16900152
For Water Temperature
 1/2" -14 NPT



18-5899
OIL PRESSURE SENDER
Replaces: 90806, 815425T, 90806A1, 815425, 34623, 8M0068784
For Oil Pressure

TEMPERATURE SENDER/OIL SENDER APPLICATION

Model	Serial No.	Oil Pressure	Water Temperature	Model	Serial No.	Oil Pressure	Water Temperature
ROVER	31400000F & UP	—	18-5897	270	2851074-3077735	18-5899	18-5897
110	1565944-1566081	18-5899	18-5898	280	4176250 & UP	18-5899	18-5898
110	1602980 & UP	18-5899	18-5898	300 MR/TRS	6668677 & UP	18-5899 ②	18-5897 ②
120	2324346 & BELOW	18-5899	18-5898	320	A543604 & UP	18-5899 ②	18-5897 ②
120	2324347 & UP	18-5899 ① ②	18-5897 ②	325	2278747 & UP	18-5899	18-5897 ⑧ ⑨
140 (4 cyl/3.0)	2508061 - 3462607	18-5899 ②	18-5897 ②	330	4623115 & UP	18-5899	18-5898
140 (4cyl/3.0)	4512156 & UP	18-5899 ②	18-5897 ②	330/W.B.W.	6083145 & UP	18-5899 ②	18-5897 ②
3.0L/3.0LX	C856559 & UP	18-5899 ②	18-5897 ②	340/7.4L	5889914 & UP	18-5899 ②	18-5897 ②
140 (6 cyl)	1566119-1725960	18-5899	18-5898	350	3780450 & UP	18-5899	18-5898
150	1666495-2048046	18-5899	18-5898	350 (Magnum)	A635178- B525981	18-5899 ②	18-5897 ②
160	2048022-2770031	18-5899	18-5897 ④ ⑤	350 (Magnum)	B525982-0505449	—	18-5897 ② ⑥ ⑦
165	2770032 & UP	18-5899	18-5897	350 (Magnum)	D505450 & UP	18-5899 ②	18-5897 ②
165/3.7L/170/180	6916779 & UP	18-5899	—	370 (TRS)	4179554 & UP	18-5899 ②	18-5897 ②
175 (262 CID)	B527955 & UP	18-5899 ②	18-5897 ② ⑥ ⑦	390	2781129-2825059	18-5899	18-5897
4.3L (Generation II)	D714107 & UP	18-5899 ②	18-5897 ②	400	4179554 & UP	18-5899	18-5897
185 (229 CID)	6330183 & UP	18-5899 ②	18-5897 ②	420/425	A398941 & UP	18-5899 ②	18-5897 ②
185 (262 CID)	A331455 & UP	18-5899 ②	18-5897 ②	440	4179554 & UP	18-5899	18-5897
190	1504311-1730903	18-5899	18-5898	454 (Magnum)	A631894 & UP	18-5899 ②	18-5897 ②
190 (4 cyl)	6916779 & UP	18-5899	—	454 (Bravo)	B721206-D805068	18-5899 ②	18-5897 ② ⑥ ⑦
200	2453769-271202	18-5899	18-5897	460	4179554	18-5899	18-5897
200	6218462 & UP	18-5899 ②	18-5897 ②	465	C849992 & UP	18-5899 ②	18-5897 ②
200/5.0	B525982 & UP	—	18-5897 ② ⑥ ⑦	500	C577254 & UP	18-5899 ②	18-5897 ②
205 (262 CID)	A331455 & UP	18-5899 ②	18-5897 ②	502 (Bravo)	C878221 & UP	18-5899 ②	18-5897 ②
205 (4.3L)	B527955 & UP	18-5899 ②	18-5897 ② ⑥ ⑦	502 (Bravo Gen V)	D824589 & UP	—	18-5897
4.3LX (Generation II)	D714370 & UP	18-5899 ②	18-5897 ②	525	D456000 & UP	18-5899 ②	18-5897 ②
215	2781153 & UP	18-5899	18-5897	575	A677429 & UP	18-5899 ②	18-5899 ②
225 (Ford)	3385721 & UP	18-5899	18-5897	888	3108723 & UP	18-5899	18-5897
225 (GM)	1632308-2694014	18-5899	18-5897 ⑧ ⑨	898	4762210-6218461	18-5899	18-5898
228	4765100-6218461	18-5899	18-5898	898	6218462 & UP	18-5899 ②	18-5897 ②
228 & 230	6218462 & UP	18-5899 ②	18-5897 ②	5.7	A338553-B514626	18-5899 ②	18-5897 ②
230 (I.B.)	5907058 & UP	18-5899 ②	18-5897 ②	5.7	B514627-B525981	18-5899 ②	18-5897 ② ⑥ ⑦
230 (5.0)	B522506 & UP	18-5899 ⑩	18-5897 ⑥ ⑦	5.7 (Bravo)	B525982 & UP	—	18-5897 ⑥ ⑦
233 Ford	4173000 & UP	18-5899	18-5898	7.4 (Bravo)	B771113-D803117	18-5899 ②	18-5897 ② ⑥ ⑦
250	9314301-4908849	18-5899	18-5897 ⑧ ⑨	7.4 (Bravo Gen V)	D803118 & UP	—	18-5897 ②
255	3258728 & UP	18-5899	18-5898	7.4L (Hurth)	ALL	18-5899 ②	18-5897 ②
260	4908850-6218461	18-5899	18-5898	454	D805069 & UP	—	18-5897 ②
260	6218462 & UP	18-5899 ②	18-5897 ②	8.2	C878221-D857199	18-5899 ②	18-5897 ②
260/5.7	B522506 & UP	18-5899 ⑩	18-5897 ⑥ ⑦	8.2	D857200 & UP	—	18-5897 ②
260	5907058 & UP	18-5899 ②	18-5897 ②				

① S/N - 3377341-3461707 & 5192049 & UP
 ② Does not include Dual application
 ④ 2326096 & UP

⑤ 2233574 & Below use 18-5898
 ⑥ (3/8 - 18)
 ⑦ (1/2 -14) Use 18-5898

⑧ Electric Choke
 ⑨ Auto Choke
 ⑩ Thru S/N B525981 only



18-70948

MOLDED HOSE

Replaces: 32-808033

Fits: 262 Mag EFI Bravo w/Fuel Cool System (1996-97), 4.3L EFI (TBI) (1998-01), 5.0L (Gen+) Bravo (1998-07), 5.0L EFI (Gen+) (1998-01), 350 Mag Alpha (Gen+) (1997), 350 Mag Alpha EFI (Gen+) (1997), 350 Mag Bravo MPI (Gen+) (1997), 350 Mag MPI (Gen+) (1998-01), 5.7L (1997), 5.7L (Gen+) (1998-07), 5.7L EFI (1997), 5.7L EFI (Gen+) 1998-2001, 5.7LX (1997), 5.7LX Bravo EFI (Gen+) (1997), 5.7LX EFI (1997)

For: Cooler to thermostat housing



18-70949

MOLDED HOSE

Replaces: 32-807407

Fits: 454 Mag MPI (Gen VI) (1996-01), 7.4LX MPI Bravo (Gen VI) (1996-97), 502 Mag MPI (Gen VI) (1996-01) **For:** Cooler to thermostat housing



18-70954

MOLDED HOSE

Replaces: 32-8600891, 32-860089

Fits: 5.0L (Gen+) Bravo (1998-07), 5.0L EFI (Gen+) Alpha & Bravo (1998-01), 350 Mag Alpha (1997), 350 Mag EFI (Gen+) Alpha (1997), 350 Mag EFI (Gen+) Alpha (1997), 350 Mag MPI (Gen+) Bravo (1997-01), 350 Mag MPI (Gen+) Alpha (1998-01), 5.7L Alpha & Bravo (1997), 5.7L (Gen+) Alpha & Bravo (1998-07), 5.7L EFI Bravo (1997-01), 5.7LX Alpha & Bravo (1997), 5.7LX EFI (Gen+) Alpha & Bravo (1997), 6.2L MPI (2000-01) **For:** oil cooler to oil cooler



18-70956

MOLDED HOSE

Replaces: 32-16012

Fits: MC175/205 (1987), 4.3L (1988-92), 4.3L (Gen II) (1992-95), 4.3LX (Gen II) (1992-95) **For:** Oil cooler to thermostat housing with all four hose connectors cast into the thermostat housing (No "T" connector) Two hoses to manifold and two hoses to elbow



18-70955

MOLDED HOSE

Replaces: 32-16011

Fits: MC200/230 (1987), 5.0L Alpha (1988-95), 5.0LX Alpha (1988-95), MC260 (1987), 350 Mag Alpha (1987-95), 5.7L Alpha & Bravo (1988-95), 454 Mag Bravo (1988-92), 7.4L (Gen V) Bravo (1992-96)

For: Oil cooler to thermostat housing with all four hose connectors cast into the thermostat housing (No "T" connector) Two hoses to manifold and two hoses to elbow



18-70952

MOLDED HOSE

Replaces: 32-887952

Fits: 5.0 L Bravo (1988-95), 5.0LX Bravo (1988-95), 350 Mag MPI Bravo (1995), 350 Mag MPI (Gen+) Bravo (1996), 5.7L Bravo (1988-96), 5.7L EFI 1995, 5.7L EFI Bravo (1996), 5.7LX EFI (Gen+) Bravo (1996) **For:** Seawater pump to oil cooler



18-70953

MOLDED HOSE

Replaces: 32-8080441

Fits: 5.0L EFI (Gen+) Bravo (1998-01), 350 Mag MPI (Gen+) (1998-01), 5.7L Bravo (1997), 5.7L (Gen+) Bravo (1998-07), 5.7L EFI Bravo 1997, 5.7L EFI (Gen+) Bravo (1998-01), 5.7LX Bravo (1997), 5.7LX EFI (Gen+) Bravo (1997), 6.2L MPI (2000-01)

For: Seawater pump to oil cooler



18-70951

MOLDED HOSE

Replaces: 32-860205, 32-8078962, 32-8078961

Fits: 262 Mag, EFI Bravo (1996-97), 4.3L (Gen+) Bravo (1998-07), 4.3L TBI (Gen+) Bravo (1998-01), 4.3LH (Gen+) Bravo (1998-02), 4.3LX(H) (Gen+) Bravo (1996-97)

For: Seawater pump to oil cooler



18-70945

MOLDED HOSE

Replaces: 32-862139

Fits: 4.3L (Gen+) (1998-07), 4.3L EFI (Gen+) (1998-01), 4.3LH (Gen+) (1998-02)

For: Thermostat housing to port manifold with 2 piece exhaust manifold



18-70947

MOLDED HOSE

Replaces: 32-862124

Fits: 4.3L (Gen+) (1998-07) (S/N 0L619000 & UP), 4.3L EFI (Gen+) (2000-01), 4.3LH (Gen+) (2000-02)

For: Thermostat housing to starboard manifold with 2 piece exhaust manifold



18-70940
MOLDED HOSE
Replaces: 32-860144
Fits: 262 Mag with Fuel Cool, 4.3L-LX (1996 & Up) with 1 pc. manifold, 5.0L-EFI (1998 & Up), 350 Mag-MPI 97-01, 5.7L-EFI (1996-97), 6.2L MPI(20 01 & Up).
For: Thermostat housing to port exhaust manifold



18-70946
MOLDED HOSE
Replaces: 32-8066362
Fits: 262 Mag EFI (Gen+) (1996-97), 4.3L (Gen+) (1998-07) (S/N 0L01004-0L618999), 4.3L EFI (Gen+) (1998-00), 4.3LH (Gen+) 1998-00), 4.3LX (Gen+) (1996-97), 4.3LXH (Gen +) (1996-97)
For: Thermostat housing to starboard manifold with 2 piece exhaust manifold



18-44092
MOLDED HOSE
TRANSOM TO T-STAT HSG
Replaces: 32-861635
For: Mercruiser 3.0L



18-70958
MOLDED HOSE
Replaces: 32-96246A4, 32-96246A1, 32-96246
Fits: MC898 (1983-84), MC200 (1985-87), MC228 (1982-84), MC230 (1985-87), 5.0L & 5.0LX Alpha (1988-95), MC260 (1983-87), 300 Tempest MR (1985-86), MC320 EFI (1987-89), 350 MAG Alpha (1986-96), 5.7L Alpha (1988-96), 5.7LX & 5.7LX EFI Alpha (1996), 454 MAG Alpha (1986-88)
For: Transom to oil cooler



18-70934
MOLDED HOSE
Replaces: 32-897181
Fits: 330 (1977-87), 330 MIE (1977-80), 340 MIE W/ BW (1981-87), 370 TRS (1978-87), 400 TRS (1980-86), 420 (1987-89), 425 (1990-92), 425 (Gen V) (1992-93), 440 TRS (1983-86), 450 (Gen V) (1995-96), 454 EFI (Gen V) (1994-96), 454 Mag Alpha (1986-88), 454 Mag Bravo (1988-92), 454 Mag Bravo(Gen V) (1992-97), 454 Mag MPI Bravo(Gen V) (1996-98), 454 Mag MPI SKI (Gen VI)(1996-97), 460 TRS (1983-86), 465 (1990-92), 465 (Gen V) (1992-94), 500 Gen + (1999), 500 (Gen V) (1994-96), 500 (Gen VI)(1997-98), 502 EFI (Gen V)(1993-95), 502 Mag Bravo (1990-92), 502 Mag MPI Bravo (Gen VI), 502 Mag Bravo(Gen V)(1992-93), 502 Mag MPI(Gen VI)(1996), 7.4L MIE W/BW (1988-92), 7.4L Bravo (1988-91), 7.4L Bravo(Gen V)(1992-96), 7.4L Bravo (Gen VI)(1996-97), 7.4L MIE (LH)(Gen V)(1992-96), 7.4L MIE (LH)(Gen VI)(1996-97), 7.4L MIE W/Hurth (1989-92), 7.4L MIE MPI (LH)(Gen VI)(1996-97), 7.4L TBI MIE (LH)(Gen VI)(1996-97), 7.4LX Bravo MPI(Gen V)(1996-97), 7.4LX Bravo TBI(Gen VI)(1996-97), 8.2L MIE (Gen V)(1993-96), 8.2L MIE MPI (Gen VI), 8.2



18-70935
MOLDED HOSE
Replaces: 32-806856
Fits: 200 2bbl (1987), 230 4bbl (1987), 260 (1987), 350 Mag SKI (1991-96), 350 Mag Alpha (1987-95), 350 Mag Alpha 4bbl (1996), 350 Mag Alpha EFI (Gen+)(1996), 350 Mag Bravo MPI (1995), 350 Mag Bravo MPI (Gen+)(1996), 350 Mag EFI SKI TBI (1994-96), 350 Mag MPI SKI (1995-96), 4.3L (Gen II)(2bbl)(1993-96), 4.3LX (Gen II)(4bbl)(1993-96), 5.0L 2bbl (1988-95), 5.0LX 4bbl (1988-95), 5.7L (1988-95), 5.7L 2bbl (1996), 5.7L Alpha EFI TBI (1995), 5.7L Bravo EFI TBI(1995), 5.7L Competition SKI (1996), 5.7L EFI (2bbl TBI)(1996), 5.7L MIE (1996), 5.7LX 4bbl (1996), 5.7LX Bravo EFI (Gen+)(1996), 5.7LX EFI 4bbl TBI (1996), Black Scorpion(Gen+)(1996)
For: Oil cooler to thermostat housing.



18-70938
MOLDED HOSE
Replaces: 32-8066351
Fits: 262 Mag with VST (1996-97), 4.3L-LX (1993-96) Design III, 5.0L-LX (1988-95) Design III, 350Mag-EFI-MPI (1987-96), 5.7L-LX 88-96 Design III
For: Thermostat housing to port exhaust manifold



18-70939
MOLDED HOSE
Replaces: 32-8066361
Fits: 4.3L-LX (1993-96) Standard Cooling Design III, 5.0L-LX/5.7L-LX (1988-95) Standard Cooling Design III, 350 Mag (1987-95) Standard Cooling Design III
For: Thermostat housing to starboard exhaust manifold



18-70943
MOLDED HOSE
Replaces: 32-897491
Fits: 7.4L, 454 Mag, 502 Mag. For Thermostat housing to port exhaust manifold



18-3601
GIMBAL HOUSING WATER FEED HOSE
Replaces: 32-32461, 32-32461A1
Dia. 3/8"
Length 13 7/8"



18-3602

WATER INTAKE HOSE

Replaces: 32-4172533, 32-8M0062309

13 7/8" Length - 3/4" I.D.

For: MR, Alpha I, Gen II



18-3603

WATER INTAKE HOSE

Replaces: 32-43437, 32-8M0090859



18-70925

MOLDED HOSE

Replaces: 32-160211, 32-87116, 32-16021

For: 4.3L, 5.0L, & 5.7L

For: Thermostat Cover to Port Manifold



18-70926

MOLDED HOSE

Replaces: 32-73796

For: 5.0L & 5.7L

For: Thermostat Cover to Exhaust Elbow



18-70927

MOLDED HOSE

Replaces: 32-73795

For: 5.0L & 5.7L Port

For: Thermostat Housing to Port Manifold



18-70928

MOLDED HOSE

Replaces: 32-71613

For: 5.0L & 5.7L

For: Thermostat Housing to Oil Cooler



18-70929

MOLDED HOSE

Replaces: 32-73794

For: 5.0L & 5.7L Starboard

For: Thermostat Housing to Starboard Manifold



18-70930

MOLDED HOSE

Replaces: 32-52481

For: GM Inline 4 & 6 cyl.

For: Water Distribution Block to End Cap



18-70931

MOLDED HOSE

Replaces: 32-96879, 32-47640, 32-8M0071007

For: 2.5L & 3.0L

For: Distribution Block to Water Pump



18-70932

MOLDED HOSE

Replaces: 32-871171, 32-87117

For: 4.3L, 5.0L, & 5.7L Starboard

For: Thermostat Cover to Starboard Manifold

SINGLE DIAMETER HOSE



4 3/4"

18-70021
MOLDED HOSE
 3/4" ID



5"

18-70704
MOLDED HOSE
 Replaces: 32-89653
 1 1/4" ID
 For: 3.7L



5"

18-70924
MOLDED HOSE
 1 3/4" ID



12 1/2"

18-71218
MOLDED HOSE
 Replaces: 32-48131, 32-48132
 1" ID
 For: 230 & 260 MIE



12 3/4"

18-71337
MOLDED HOSE
 Replaces: 32-861590A05, 32-861590A2, 32-861590A1,
 32-806825
 1 3/4" ID
 For: 4.3L, 5.0L, 5.7L
 Circulating Pump Hose

STRAIGHT HOSE



18-75100
MOLDED HOSE
 Replaces: 32-8M0062614
 Straight 48"
 1" ID



18-75125
MOLDED HOSE
 Replaces: 32-8M0062665, 32-865672070, 32-5346170
 Straight 48"
 1 1/4" ID

HOSE INTERCHANGE

Part No.	Mercuriser Part No.	Part No.	Mercuriser Part No.	Part No.	Mercuriser Part No.
18-70925	32-16021 1	18-70928	32-71613	18-70940	32-860144
18-3601	32-32461	18-70929	32-73794	18-71337	32-87108
18-71337	32-33189	18-70927	32-73795	18-70932	32-87117 1
18-3602	32-41725-33	18-70926	32-73796	18-70704	32-89653
18-3603	32-43437	18-70938	32-806635 1	18-70934	32-89718 1
18-71218	32-48132	18-70939	32-806636 1	18-70943	32-89749 1
18-70930	32-52481	18-70935	32-806856	18-70931	32-96879

V-BELTS



- 1 High strength synthetic cords resist shockload failure. Their low stretch properties assure uniform performance over the life of the belt.
- 2 The compression section is a special rubber compound that assures smooth and even transfer of load forces to the cords.
- 3 Cogs are molded to precise engineering tolerances to improve flexibility and maintain cord support. Cog geometry provides a large area for air circulation to keep the belt cool and prevent damaging heat build up in the cushion section.
- 4 Rubber edges maintain positive, no-slip contact with pulley grooves for reliable energy transfer.

BELT SIZE LISTING BY NUMBER

Part No.	OE #	Effective Length (in.)	Top Width (in.)	Part No.	OE #	Effective Length (in.)	Top Width (in.)
18-15290	57-13457, 57-13457T, 57-13457Q, 57-53215, 57-53215T	29	29/64	18-15435	57-64416, 57-49211	43 1/2	29/64
18-15300	57-49756	30	29/64	18-15440	57-49213A1, 57-45856	44	29/64
18-15325	57-77274A1, 57-77274	32 1/2	29/64	18-15450	-	45	29/64
18-15345	57-74271T, 57-74271, 57-74271Q	34 1/2	29/64	18-15455	-	45 1/2	29/64
18-15370	57-65607T, 57-65607, 57-65607Q	37	29/64	18-15460	57-48120A1, 57-48120, 57-48120Q1	46	29/64
18-15380	-	38	29/64	18-15470	57-78200A1, 57-78200, 57-78200Q1	47	29/64
18-15390	57-52692	39	29/64	18-15480	57-48122, 57-48122Q	48	29/64
18-15400	57-32850, 57-69143T, 57-69143Q	40	29/64	18-15490	57-816295T, 57-816295Q	52 1/2	29/64
18-15405	57-76269, 57-76269Q	40 1/2	29/64	18-15495	57-91035A1, 57-91035Q1, 57-91035	49 1/2	29/64
18-15410	57-49043A1, 57-64032A1, 57-32850, 57-49043, 57-64032, 57-64032Q1, 57-816544	41	29/64	18-15500	57-96834T, 57-96834Q, 57-96834, 57-13458, 57-13458Q	50	29/64
18-15415	57-36356	41 1/2	29/64	18-15520	57-33170, 57-33170Q, 57-37619T	52	29/64
18-15430	57-49211, 57-64416	43	29/64	18-15550	57-13458T	55	29/64

V-BELT APPLICATION

HP	Liter	Model	Years	CID	# Cyl	Stroke	Serial #	Belt Type	Alternator/ Water Pump	Power Steering	Sea Water Pump
110		110	1963-1966	153	4	4	1537370 - 2044033	V-BELT	18-15410	—	—
120		120	1964-1973	153	4	4	1666601 - 3770649	V-BELT	18-15410	—	—
120		120	1974-1982	153	4	4	3770650 - 6229717	V-BELT	18-15410	18-15400 (40" BELT)	—
120		120	1974-1982	153	4	4	3770650 - 6229717	V-BELT	18-15410	18-15400 (40" BELT)	—
120		120	1982-1986	153	4	4	6229718 - b531853	V-BELT	18-15410 (19)	—	—
120		120	1982-1986	153	4	4	6229718 - b531853	V-BELT	18-15400 (18)	—	—
120	2.5L	120	1982-89	153	4	4	6229718 - C853255	V-BELT	18-15410	—	—
120	2.5L	120 (18)	1982-89	153	4	4	6229718 - C853255	V-BELT	18-15400	18-15370	—
140		140	1968-73	181	4	4	2508261-3770649	V-BELT	18-15410	—	—

- (1) 1/2" wide (13mm) belt
- (2) 3/8" wide (10mm) belt
- (3) 28" wide (711mm) belt
- (4) 30" wide (762mm) belt
- (5) 37" wide (940mm) belt
- (6) 40" wide (1016mm) belt
- (7) 50" wide (1270mm) belt
- (8) 55" wide (1397mm) belt

- (9) Use with 5 1/2" (140mm) dia water pump pulley
- (10) Use with 5 7/8" (149mm) dia water pump pulley
- (11) Use with 7" (178mm) dia water pump pulley
- (12) Use with stamped steel sea water pump pulley
- (13) Use with cast aluminum sea water pump pulley
- (14) Use with plastic 4 3/4" (121mm) dia p/s pump pulley
- (15) Use with metal 5 3/4" (146mm) dia p/s pump pulley
- (16) For engine with high mounted p/s pump

- (17) For engines with low mounted p/s pump
- (18) For engine with power steering
- (19) For engines w/o power steering
- (20) For engines with closed cooling
- (21) For engines with standard cooling
- (22) Replacement kit includes 5 3/4" (146mm) pulley and longer serpentine belt
- (23) For engines with high mounted alternator

V-BELT APPLICATION

HP	Liter	Model	Years	CID	# Cyl	Stroke	Serial #	Belt Type	Alternator/ Water Pump	Power Steering	Sea Water Pump
140		140	1974-82	181	4	4	3770650-6229717	V-BELT	18-15410	18-15370 (37" BELT)	—
140		140	1974-82	181	4	4	3770650-6229717	V-BELT	18-15410	18-15400 (40" BELT)	—
140	3.0L	140 / 3.0L / 3.0LX	1982-1986	181	4	4	6229718 - B450800	V-BELT	18-15410 (19)	—	—
140	3.0L	140 / 3.0L / 3.0LX	1982-1999	181	4	4	6229718 - B450800	V-BELT	18-15400 (18)	18-15370	—
140	3.0L	3.0L	1987-1994	181	4	4	6229718 - F603999	V-BELT	18-15400 (18)	18-15370	—
140	3.0L	3.0L	1987-1994	181	4	4	6229718 - F603999	V-BELT	18-15400 (18)	18-15370	—
	3.0L	3.0L	1998-1999	181	4	4	L010042 - L382121	V-BELT	18-15400	18-15370	—
	3.0L	3.0L	1999-2010	181	4	4	L382122 & UP	V-BELT	—	18-15370	—
	3.0L	3.0LX	1990-1995	181	4	4	C856559 - F603999	V-BELT	18-15410 (19)	—	—
	3.0L	3.0LX	1990-1995	181	4	4	C856559 - F603999	V-BELT	18-15400 (18)	18-15370	—
	3.0L	3.0LX	1986-1997	181	4	4	F604000 - K999999	V-BELT	18-15400	18-15370	—
	3.0L	3.0L MPI	2008-2010	181	4	4	A072812 & UP	V-BELT	—	18-15370	—
150		150	1964-66		4	4	1666495-2048646	V-BELT	18-15410	—	—
160		160	1967-69		4	4	2048022-2770031	V-BELT	18-15410	—	—
165		165	1987	224	4	4	B434941 - B774251	V-BELT	—	18-15410	—
165		165	1970-73		4	4	2770032 - 3774864	V-BELT	18-15410	—	—
165		165	1974-81		4	4	3774865 - 5813433	V-BELT	18-15410	18-15370 (37" BELT)	—
165		165	1974-81		4	4	3774865 - 5813433	V-BELT	18-15410	18-15400 (40" BELT)	—
170	3.7L	165 / 170 / 180 / 190 / 3.7L	1985-89		4	4	6916779 - C762299	V-BELT	—	18-15410	—
170		170	1985-1986	224	4	4	6916779 - B434940	V-BELT	—	18-15410	—
170		470	1976-82		4	4	4208730 - 6218036	V-BELT	—	18-15405	—
170		470	1983-84		4	4	6218037 - 6916778	V-BELT	—	18-15410	—
		488	1983-84		4	4	6170297 - 6916778	V-BELT	—	18-15410	—
175		175	1987		4	4	OB527955-OB773242	V-BELT	—	18-15490	—
180		180	1987	224	4	4	B436391 - B775248	V-BELT	—	18-15410	—
190		190	1985-1986	224	4	4	691779 - B436390	V-BELT	—	18-15410	—
	3.7L	3.7L	1988-1989	224	4	4	B774252 - C762299	V-BELT	—	18-15410	—
	3.7L	3.7LX	1988-1989	224	4	4	B775249 - C762299	V-BELT	—	18-15410	—
		470	1983-1984	224	4	4	6218037 - 6916778	V-BELT	—	18-15410	—
		470 MIE	1980-1981	224	4	4	5520115 - 6218036	V-BELT	—	—	18-15345
		485	1980-1982	224	4	4	5685394 - 6218036	V-BELT	—	18-15410	—
		488	1983-1984	224	4	4	6170297 - 6916778	V-BELT	—	18-15410	—
		140	1963	194	6	4	1538930 - 1725960	V-BELT	18-15410	—	—
		150	1964-1966	230	6	4	1666495 - 2048046	V-BELT	18-15410	—	—
		160	1967-1969	250	6	4	2048022 - 2770031	V-BELT	18-15410	—	—
		165	1970-1973	250	6	4	2770032 - 3774864	V-BELT	18-15410	—	—
140		165	1974-1981	250	6	4	3774865 - 5813433	V-BELT	18-15410	18-15370 (37" BELT)	—
150		165	1974-1981	250	6	4	3774865 - 5813433	V-BELT	18-15410	18-15400 (40" BELT)	—
		200	1969	292	6	4	2453769 - 2712072	V-BELT	18-15410	—	—
		185 (4bb)	1983-1984	229	6	4	6330183 - M6919655	V-BELT	—	18-15520	18-15345
		175	1987	262	6	4	B527955 - B773242	V-BELT	—	18-15520	18-15345
		185 (2bb)	1985-1986	262	6	4	A331455 - B527954	V-BELT	—	18-15520	18-15345
		205	1985-1987	262	6	4	A331455 - B775129	V-BELT	—	18-15520	18-15345
		205	1985-1991			4	A331455 - D714369	V-BELT	18-15440	18-15520	18-15345
		205	1987			4	B527955 - OB775129	V-BELT	—	18-15490	—
		4.3L (2bb)	1988-92	262	6	4	OB773243-OD714106	V-BELT	—	18-15490	—
		4.3L	1992-96	262	6	4	D714107 - F802999	V-BELT	18-15460	—	18-15290
		4.3L ALPHA RWC	1996-1999	262	6	4	F803000 - L618999	SERPENTINE	18-15116 (14, 21, 22)	—	—
		4.3L ALPHA FWC	1996-1999	262	6	4	F803000 - L618999	SERPENTINE	18-15117 (14, 20, 22)	—	—
	4.3L	4.3L ALPHA RWC	1996-1999	262	6	4	F803000 - L618999	SERPENTINE	18-15116 (15, 21)	—	—
	4.3L	4.3L ALPHA FWC	1996-1999	262	6	4	F803000 - L618999	SERPENTINE	18-15117 (15, 20)	—	—
	4.3L	4.3L ALPHA RWC (19)	1996-1999	262	6	4	F803000 - L618999	SERPENTINE	18-15113 (19)	—	—
	4.3L	175 / 185 / 4.3L	1985-92	262	6	4	A331455 - D714106	V-BELT	18-15440	18-15520	18-15345
	4.3L	4.3L Gen II (2bb)	1992-96	262	6	4	OD714107-OF802999	V-BELT	—	18-15490	—
	4.3L	4.3LX (4bb)	1988-92	262	6	4	OB775130-OD714369	V-BELT	—	18-15490	—

- (1) 1/2" wide (13mm) belt
- (2) 3/8" wide (10mm) belt
- (3) 28" wide (711mm) belt
- (4) 30" wide (762mm) belt
- (5) 37" wide (940mm) belt
- (6) 40" wide (1016mm) belt
- (7) 50" wide (1270mm) belt
- (8) 55" wide (1397mm) belt

- (9) Use with 5 1/2" (140mm) dia water pump pulley
- (10) Use with 5 7/8" (149mm) dia water pump pulley
- (11) Use with 7" (178mm) dia water pump pulley
- (12) Use with stamped steel sea water pump pulley
- (13) Use with cast aluminum sea water pump pulley
- (14) Use with plastic 4 3/4" (121mm) dia p/s pump pulley
- (15) Use with metal 5 3/4" (146mm) dia p/s pump pulley
- (16) For engine with high mounted p/s pump

- (17) For engines with low mounted p/s pump
- (18) For engine with power steering
- (19) For engines w/o power steering
- (20) For engines with closed cooling
- (21) For engines with standard cooling
- (22) Replacement kit includes 5 3/4" (146mm) pulley and longer serpentine belt
- (23) For engines with high mounted alternator

V-BELT APPLICATION

HP	Liter	Model	Years	CID	# Cyl	Stroke	Serial #	Belt Type	Alternator/ Water Pump	Power Steering	Sea Water Pump
	4.3L	4.3LX Gen II (4bb)	1992-96	262	6	4	OD714370-OF802999	V-BELT	—	18-15490	—
	4.3L	4.3L BRAVO RWC	1996-1999	262	6	4	F803000 - L618999	SERPENTINE	18-15115 (14, 21, 22)	—	—
	4.3L	4.3L BRAVO FWC	1996-1999	262	6	4	F803000 - L618999	SERPENTINE	18-15114 (14, 20, 22)	—	—
	4.3L	4.3L BRAVO RWC	1996-1999	262	6	4	F803000 - L618999	SERPENTINE	18-15115 (15, 21)	—	—
	4.3L	4.3L BRAVO FWC	1996-1999	262	6	4	F803000 - L618999	SERPENTINE	18-15114 (15, 20)	—	—
	4.3L	4.3L BRAVO RWC (19)	1996-1999	262	6	4	F803000 - L618999	SERPENTINE	18-15113 (19)	—	—
	5.0L	215	1970-1972	302	8	4	2781153 - 3563181	V-BELT	18-15440	—	—
	5.0L	215 MIE	1970-1972	302	8	4	2781153 - 3563181	V-BELT	18-15440	—	—
	5.0L	225 (FORD)	1973-74	302	8	4	3385721 - 4166999	V-BELT	18-15440	18-15520	18-15345
	5.0L	225 MIE (FORD)	1973-74	302	8	4	3385721 - 4166999	V-BELT	18-15440	—	—
	5.0L	888 (FORD)	1971-1977	302	8	4	3108723 - 4887829	V-BELT	18-15440 (28" BELT)	— (28" BELT)	—
	5.0L	888 (FORD)	1971-1977	302	8	4	3108723 - 4887829	V-BELT	18-15440 (30" BELT)	18-15290 (30" BELT)	18-15440
	5.0L	198 MIE	1977	305	8	4	4762210 - 6218461	V-BELT	18-15460	—	18-15345
	5.0L	200	1985-1987	305	8	4	6899058 - B774444	V-BELT	— (9)	18-15520 (9)	18-15345
	5.0L	200	1985-1987	305	8	4	6899058 - B774444	V-BELT	18-15460 (11)	18-15490 (11)	18-15345
	5.0L	200	1987		8	4	2453769 - 2712072	V-BELT	18-15410	—	—
	5.0L	200	1987		8	4	B525982-B774444	V-BELT	—	18-15490	—
		225 MCM / 225 MIE	1967-69		8	4	2278647 - 2694014	V-BELT	18-15460	—	—
	5.0L	228	1977-1982	305	8	4	4765100-6218461	V-BELT	18-15460 (17)	18-15325	18-15345
	5.0L	228	1977-1982	305	8	4	4765100-6218461	V-BELT	18-15440 (16)	18-15495	18-15345
	5.0L	228	1983-1984	305	8	4	6218462 - 6899268	V-BELT	— (9)	18-15520 (9)	18-15345
	5.0L	228	1983-1984	305	8	4	6218462 - 6899268	V-BELT	18-15460 (11)	18-15490 (11)	18-15345
	5.0L	228 MIE	1977	305	8	4	4765100 - 4929029	V-BELT	18-15460	—	18-15345
	5.0L	228 MIE	1978-1980	305	8	4	4929030 - 5907057	V-BELT	— (9)	—	18-15345 (12)
	5.0L	228 MIE	1978-1980	305	8	4	4929030 - 5907057	V-BELT	18-15460 (11)	—	18-15290 (13)
	5.0L	228 MIE	1977	305	8	4	4765100 - 4929030	V-BELT	18-15460	—	18-15325
	5.0L	228 / 230 / 5.0L	1983-95		8	4	6218462 - F600999	V-BELT	18-15440	18-15495	18-15345 (20)
	5.0L	228 / 230 / 5.0L	1983-95		8	4	6218462 - F600999	V-BELT	18-15460	18-15520	18-15290 (21)
	5.0L	228 / 230 / 5.0L MIE	1978-87		8	4	4929030 - B788151	V-BELT	18-15440	18-15495	18-15345 (12)
	5.0L	228 / 230 / 5.0L MIE	1978-87		8	4	4929030 - B788151	V-BELT	18-15460	18-15520	18-15290 (13)
	5.0L	230	1985-1987	305	8	4	6899269 - B773739	V-BELT	18-15520 (9)	18-15520 (9)	18-15345
	5.0L	230	1983-1984	305	8	4	6899269 - B773739	V-BELT	18-15460 (11)	18-15490 (11)	18-15345
	5.0L	230 MIE	1981-1987	305	8	4	5907058 - B788151	V-BELT	— (9)	—	18-15345 (12)
	5.0L	230 MIE	1981-1987	305	8	4	5907058 - B788151	V-BELT	18-15460 (11)	—	18-15290 (13)
		230	1987		8	4	B525982-B773739	V-BELT	—	18-15490	—
		233	1975-77			4	4173000 - 4902304	V-BELT	18-15440	—	—
		233	1975-77			4	4173000 - 4902304	V-BELT	18-15440	18-15290	18-15345 (12)
		233 MIE	1975-76			4	4173000 - 4775784	V-BELT	18-15440	—	—
	5.0L	5.0L	1988-1995	305	8	4	B774445 - F600999	V-BELT	— (9)	18-15520 (9)	18-15345 (12)
	5.0L	5.0L	1988-1995	305	8	4	B774445 - F600999	V-BELT	18-15460 (11)	18-15490 (11)	18-15290 (13)
	5.0L	5.0L ALPHA RWC	1998-1999	305	8	4	L012052 - L618999	SERPENTINE	18-15116 (1, 14, 21, 22)	—	—
	5.0L	5.0L ALPHA FWC	1998-1999	305	8	4	L012052 - L618999	SERPENTINE	18-15114 (14, 20, 22)	—	—
	5.0L	5.0L ALPHA RWC	1998-1999	305	8	4	L012052 - L618999	SERPENTINE	18-15116 (15, 21)	—	—
	5.0L	5.0L ALPHA FWC	1998-1999	305	8	4	L012052 - L618999	SERPENTINE	18-15114 (15, 20)	—	—
	5.0L	5.0L BRAVO RWC	1998-1999	305	8	4	L012052 - L618999	SERPENTINE	18-15115 (1, 14, 20, 22)	—	—
	5.0L	5.0L BRAVO FWC	1998-1999	305	8	4	L012052 - L618999	SERPENTINE	18-15114 (1, 14, 21, 22)	—	—
	5.0L	5.0L BRAVO RWC	1998-1999	305	8	4	L012052 - L618999	SERPENTINE	18-15115 (15, 21)	—	—
	5.0L	5.0L BRAVO FWC	1998-1999	305	8	4	L012052 - L618999	SERPENTINE	18-15114 (15, 20)	—	—
	5.0L	5.0L MIE	1988	305	8	4	B788152 - C396832	V-BELT	18-15460 (11)	—	57-13457Q (13)
	5.0L	5.0LX	1988	305	8	4	6218462 - F600999	V-BELT	— (9)	18-15520 (9)	57-74271Q (12)
	5.0L	5.0LX	1983-1995	305	8	4	6218462 - F600999	V-BELT	18-15460 (11)	18-15490 (11)	57-13457Q (13)
	5.0L	5.0L (2bb)	1988-95		8	4	B774445-F600999	V-BELT	—	18-15490	—
	5.0L	5.0LX (4bb)	1988-95		4	4	B773740-F600999	V-BELT	—	18-15490	—
	5.0L	898	1977-1984	305	8	4	4762210 - 6218461	V-BELT	18-15460 (17)	18-15325 (17)	18-15345
	5.0L	898	1977-1984	305	8	4	4762210 - 6218461	V-BELT	18-15440 (16)	18-15495	18-15345

- (1) 1/2" wide (13mm) belt
- (2) 3/8" wide (10mm) belt
- (3) 28" wide (711mm) belt
- (4) 30" wide (762mm) belt
- (5) 37" wide (940mm) belt
- (6) 40" wide (1016mm) belt
- (7) 50" wide (1270mm) belt
- (8) 55" wide (1397mm) belt

- (9) Use with 5 1/2" (140mm) dia water pump pulley
- (10) Use with 5 7/8" (149mm) dia water pump pulley
- (11) Use with 7" (178mm) dia water pump pulley
- (12) Use with stamped steel sea water pump pulley
- (13) Use with cast aluminum sea water pump pulley
- (14) Use with plastic 4 3/4" (121mm) dia p/s pump pulley
- (15) Use with metal 5 3/4" (146mm) dia p/s pump pulley
- (16) For engine with high mounted p/s pump

- (17) For engines with low mounted p/s pump
- (18) For engine with power steering
- (19) For engines w/o power steering
- (20) For engines with closed cooling
- (21) For engines with standard cooling
- (22) Replacement kit includes 5 3/4" (146mm) pulley and longer serpentine belt
- (23) For engines with high mounted alternator

V-BELT APPLICATION

HP	Liter	Model	Years	CID	# Cyl	Stroke	Serial #	Belt Type	Alternator/ Water Pump	Power Steering	Sea Water Pump
	5.0L	898	1983-1984	305	8	4	6218462 - 6899057	V-BELT	— (9)	18-15520 (9)	18-15345 (9)
	5.0L	898	1983-1984	305	8	4	6218462 - 6899057	V-BELT	18-15460 (11)	18-15490 (11)	18-15345
	5.0L	898 / 200 / 5.0L	1985-1995	305	8	4	6218462 - F600999	V-BELT	18-15440 (20)	18-15495	18-15345
	5.0L	898 / 200 / 5.0L	1985-1995	305	8	4	6218462 - F600999	V-BELT	18-15460 (21)	18-15520	18-15290
	5.7L	250 MCM / 250 MIE	1968-69	350	8	4	2314301 - 2639854	V-BELT	18-15460	—	—
	5.7L	250	1977	350	8	4	4768000 - 4908849	V-BELT	18-15440	18-15345	18-15345
	5.7L	255 MCM / 255MIE	1973-74	350	8	4	3258728 - 4175499	V-BELT	18-15440	—	—
	5.7L	255 (GM)	1975-76	350	8	4	4175500 - 4498700	V-BELT	18-15460	18-15300	18-15345
	5.7L	255 (GM)	1976	350	8	4	4498701-4499060	V-BELT	18-15460	—	18-15345
	5.7L	255 (GM)	1976	350	8	4	4499061-4767999	V-BELT	18-15460	—	18-15345
	5.7L	255 MIE (GM)	1975-77	350	8	4	4175500 - 4498700	V-BELT	18-15460	—	18-15345
	5.7L	255 MIE (GM)	1977-78	350	8	4	4498701 - 4924564	V-BELT	18-15460	—	18-15345
	5.7L	255 MIE (GM)	1978-1980	350	8	4	4924565 - 5907057	V-BELT	—	—	18-15345
	5.7L	260 MIE	1978-86	350	8	4	4924565 - B522505	V-BELT	18-15440	—	18-15345
	5.7L	260 / 5.7L MIE / 5.7L Ski	1987-93	350	8	4	B522506 - F024999	V-BELT	18-15440	—	18-15345 (12)
	5.7L	260 / 5.7L MIE / 5.7L Ski	1987-93	350	8	4	B522506 - F024999	V-BELT	18-15460	—	18-15290 (13)
	5.7L	260	1978-1982	350	8	4	4908850 - 6218461	V-BELT	18-15440 (16)	18-15495 (17)	18-15345
	5.7L	260	1978-1982	350	8	4	4908850 - 6218461	V-BELT	18-15460 (17)	—	18-15345
	5.7L	260	1987	350	8	4	B525982-B773304	V-BELT	—	18-15490	—
	5.7L	260	1983-1987	350	8	4	6218462 - B773304	V-BELT	18-15460 (11)	18-15490 (11)	18-15290 (13)
	5.7L	260 MIE	1987	350	8	4	B522506 - B788151	V-BELT	18-15460 (11)	—	18-15290 (13)
	5.7L	260 / 5.7L	1983-1995	350	8	4	6218462 - F600999	V-BELT	18-15440	18-15495	18-15345 (20)
	5.7L	260 / 5.7L	1983-1995	350	8	4	6218462 - F600999	V-BELT	18-15460	18-15520	18-15290 (21)
	5.7L	270 MCM / 270 MIE	1969-1972	350	8	4	2851074 - 3385720	V-BELT	18-15460	—	—
	5.7L	280 TRS	1975	350	8	4	4176250 - 4176468	V-BELT	18-15460	—	—
	5.7L	280 TRS	1975	350	8	4	4176250 - 4176468	V-BELT	18-15460	18-15300	—
	5.7L	280 TRS	1975-76	350	8	4	4176469 - 4499390	V-BELT	18-15460	18-15300	—
	5.7L	280 TRS	1976	350	8	4	4499391 - 4499780	V-BELT	18-15460	—	—
	5.7L	280 TRS	1976	350	8	4	4499781 - 4770199	V-BELT	18-15460	18-15325	—
		320 EFI	1987-89		8	4	A543604 - C622418	V-BELT	18-15440	18-15520	—
		330	1977-81		8	4	4623115-6083144		18-15470	—	18-15345
		330	1982-87		8	4	6083144 - B816540		18-15470	18-15500	18-15345 (12)
		330	1982-87		8	4	6083144 - B816540		18-15470	18-15550	18-15290 (13)
	5.7L	350 MAG ALPHA	1986-1995	350	8	4	A635178 - F600999	V-BELT	18-15440 (9)	18-15520 (9)	18-15345 (20)
	5.7L	350 MAG ALPHA	1986-1995	350	8	4	A635178 - F600999	V-BELT	18-15460 (11)	18-15490 (11)	18-15290 (21)
	5.7L	350 MAG ALPHA	1996	350	8	4	F601000 - K001500	V-BELT	18-15460	18-15490	18-15290
	5.7L	350 Mag Alpha	1987-1995	350	8	4	B525982 - F600999	V-BELT	—	18-15490	—
	5.7L	350 Mag Alpha (4bbl)	1996	350	8	4	F601000 - K001526	V-BELT	—	18-15490	—
	5.7L	350 Mag Alpha EFI /									
		350 Mag ALPHA Gen+	1996	350	8	4	F800300 - K001508	V-BELT	—	18-15490	—
	5.7L	350 Mag Bravo MPI	1995	350	8	4	F415189 - F601999	V-BELT	—	18-15490	—
	5.7L	350 Mag Bravo MPI /									
		350 Mag Bravo MPI Gen+	1996	350	8	4	F602000 - K001500	V-BELT	—	18-15490	—
	5.7L	350 MAG Ski	1991-96	350	8	4	D505450 - K040005	V-BELT	18-15460	—	18-15290
	5.7L	350 MAG ALPHA RWC	1997-1999	350	8	4	K001501 - L618999	SERPENTINE	18-15116 (14, 21, 22)	—	—
	5.7L	350 MAG ALPHA FWC	1997-1999	350	8	4	K001501 - L618999	SERPENTINE	18-15114 (14, 20, 22)	—	—
	5.7L	350 MAG ALPHA RWC	1997-1999	350	8	4	K001501 - L618999	SERPENTINE	18-15116 (15, 20)	—	—
	5.7L	350 MAG ALPHA FWC	1997-1999	350	8	4	K001501 - L618999	SERPENTINE	18-15114 (15, 21)	—	—
	5.7L	350 MAG BRAVO RWC	1997-1999	350	8	4	K001501 - L618999	SERPENTINE	18-15115 (14, 21, 22)	—	—
	5.7L	350 MAG BRAVO FWC	1997-1999	350	8	4	K001501 - L618999	SERPENTINE	18-15114 (14, 20, 22)	—	—
	5.7L	350 MAG BRAVO RWC	1997-1999	350	8	4	K001501 - L618999	SERPENTINE	18-15115 (15, 21)	—	—
	5.7L	350 MAG BRAVO FWC	1997-1999	350	8	4	K001501 - L618999	SERPENTINE	18-15114 (15, 20)	—	—
	5.7L	350 MIE	1974-75	350	8	4	3780450-4501640		18-15480	—	—
	5.7L	350 MIE	1976	350	8	4	4501641 - 4623109		18-15480	—	18-15345
	5.7L	350 MAG MPI / 350 MAG SKI	1995-1996	350	8	4	F350583 - F799999	V-BELT	18-15460	—	18-15290

- (1) 1/2" wide (13mm) belt
- (2) 3/8" wide (10mm) belt
- (3) 28" wide (711mm) belt
- (4) 30" wide (762mm) belt
- (5) 37" wide (940mm) belt
- (6) 40" wide (1016mm) belt
- (7) 50" wide (1270mm) belt
- (8) 55" wide (1397mm) belt

- (9) Use with 5 1/2" (140mm) dia water pump pulley
- (10) Use with 5 7/8" (149mm) dia water pump pulley
- (11) Use with 7" (178mm) dia water pump pulley
- (12) Use with stamped steel sea water pump pulley
- (13) Use with cast aluminum sea water pump pulley
- (14) Use with plastic 4 3/4" (121mm) dia p/s pump pulley
- (15) Use with metal 5 3/4" (146mm) dia p/s pump pulley
- (16) For engine with high mounted p/s pump

- (17) For engines with low mounted p/s pump
- (18) For engine with power steering
- (19) For engines w/o power steering
- (20) For engines with closed cooling
- (21) For engines with standard cooling
- (22) Replacement kit includes 5 3/4" (146mm) pulley and longer serpentine belt
- (23) For engines with high mounted alternator

V-BELT APPLICATION

HP	Liter	Model	Years	CID	# Cyl	Stroke	Serial #	Belt Type	Alternator/ Water Pump	Power Steering	Sea Water Pump
	5.7L	350 MAG SKI	1991-1996	350	8	4	D505450 - K040005	V-BELT	18-15460	—	18-15290 (12)
	5.7L	5.7L	1988-1995	350	8	4	B773305 - F600999	V-BELT	— (9)	18-15520 (9)	18-15345
	5.7L	5.7L	1988-1995	350	8	4	B773305 - F600999	V-BELT	18-15460 (11)	18-15490 (11)	18-15290
	5.7L	5.7L	1996	350	8	4	F601000 - K001505	V-BELT	18-15460	18-15490	18-15290
	5.7L	5.7L ALPHA RWC	1997-1999	350	8	4	K001506 - L618999	SERPENTINE	18-15116 (14, 21, 22)	—	—
	5.7L	5.7L ALPHA FWC	1997-1999	350	8	4	K001506 - L618999	SERPENTINE	18-15114 (14, 20, 22)	—	—
	5.7L	5.7L ALPHA RWC	1997-1999	350	8	4	K001506 - L618999	SERPENTINE	18-15116 (15, 21)	—	—
	5.7L	5.7L ALPHA FWC	1997-1999	350	8	4	K001506 - L618999	SERPENTINE	18-15114 (15, 20)	—	—
	5.7L	5.7L BRAVO FWC	1997-1999	350	8	4	K001506 - L618999	SERPENTINE	18-15114 (14, 20, 22)	—	—
	5.7L	5.7L BRAVO RWC	1997-1999	350	8	4	K001506 - L618999	SERPENTINE	18-15115 (15, 21)	—	—
	5.7L	5.7L BRAVO FWC	1997-1999	350	8	4	K001506 - L618999	SERPENTINE	18-15114 (15, 20)	—	—
	5.7L	5.7L MIE	1988-1993	350	8	4	B522506 - F024999	V-BELT	—	—	18-15345
	5.7L	5.7L MIE	1988-1993	350	8	4	B522506 - F024999	V-BELT	—	—	18-15290
	5.7L	5.7L MIE	1994-1996	350	8	4	F025000 - K040306	V-BELT	18-15460	—	18-15290
	5.7L	5.7L SKI	1985-1987	350	8	4	A338553 - B514626	V-BELT	—	—	18-15290 (13)
	5.7L	5.7L SKI	1987-1995	350	8	4	B514627 - F775199	V-BELT	—	—	18-15345
	5.7L	5.7L SKI	1987-1995	350	8	4	B514627 - F775199	V-BELT	—	—	18-15290
	5.7L	5.7L SKI	1996	350	8	4	F775200 - K040003	V-BELT	18-15460	—	18-15290
	5.7L	5.7LX	1996	350	8	4	F601000 - K001505	V-BELT	18-15460	18-15490	18-15290
	5.7L	5.7L BRAVO EFI	1996	350	8	4	F800300 - K001505	V-BELT	18-15460	18-15490	18-15290
	5.7L	5.7LX BRAVO	1996	350	8	4	F601000 - K001505	V-BELT	18-15460	18-15490	18-15290
	5.7L	BLACK SCORPION SKI	1996	350	8	4	F800000 - K040000	V-BELT	18-15460	—	18-15290
	5.7L	5.7L MIE / 5.7L Ski	1994-96	350	8	4	F025000 - K040306		18-15460	—	—
	5.7L	5.7L	1988-96	350	8	4	B525982 - F600999		—	18-15490	—
	5.7L	5.7L (2bbi)	1996	350	8	4	F601000 - K001526		—	18-15490	—
	5.7L	5.7L EFI (2bbi)	1996	350	8	4	F752400 - K001505		—	18-15490	—
	5.7L	5.7L Alpha EFI / 5.7L ALPHA TBI	1995	350	8	4	F355305 - F752399		—	18-15490	—
	5.7L	5.7L Alpha EFI / 5.7L ALPHA TBI	1995	350	8	4	F225560 - F752399		—	18-15490	— (13)
	5.7L	5.7LX EFI / 5.7LX TBI (4bbi)	1996	350	8	4	F752400 - K001505		—	18-15490	— (12)
	5.7L	233	1975-1977	351	8	4	4173000 - 4902304	V-BELT	—	18-15290 (30° BELT)	18-15345
	6.2L	377 SCORPION MCM	1999-2005	377	8	4	L416146 - M907201	SERPENTINE	18-15115	—	—
	7.4L	325 MCM / 325 MIE	1968-1974	427	8	4	2278747 - 3780449	V-BELT	18-15480	—	—
	7.4L	330	1977-1981	454	8	4	4623115 - 6083144	V-BELT	18-15470	—	18-15345
	7.4L	330	1982-1987	454	8	4	6083145 - B816540	V-BELT	18-15470	18-15500 (50° BELT)	18-15345 (12)
	7.4L	330	1982-1987	454	8	4	6083145 - B816540	V-BELT	18-15470	18-15550 (55° BELT)	18-15290 (13)
	7.4L	330 MIE	1977-1980	454	8	4	4623115 - 5889913	V-BELT	18-15470	—	18-15345
	7.4L	340 MIE	1981-1987	454	8	4	5889914 - B788365	V-BELT	18-15470	—	18-15345 (12)
	7.4L	340 MIE	1981-1987	454	8	4	5889914 - B788365	V-BELT	18-15470	—	18-15290 (13)
	7.4L	340	1981-92	454	8	4	5889914 - D715493	V-BELT	18-15470	—	18-15345 (12)
	7.4L	340	1981-92	454	8	4	5889914 - D715493	V-BELT	18-15470	—	18-15290 (13)
	7.4L	350 MIE	1974-1975	454	8	4	3780450 - 4501640	V-BELT	18-15480	—	—
	7.4L	350 MIE	1976	454	8	4	4501641 - 4623109	V-BELT	18-15480	—	18-15345
	7.4L	370 TRS	1978-1985	454	8	4	4179554 - 6721527	V-BELT	18-15480	—	—
	7.4L	370 TRS	1985-1987	454	8	4	6721528 - B714586	V-BELT	18-15480	18-15500	18-15345
	7.4L	400 TRS	1980-1986	454	8	4	4179554 - B457644	V-BELT	18-15480	—	—
	7.4L	420	1987-1989	454	8	4	A398941 - B622418	V-BELT	—	18-15500	18-15345
	7.4L	425	1990-1992	454	8	4	B622419 - D725499	V-BELT	—	18-15500	18-15345
	7.4L	425	1992	454	8	4	D725500 - D937011	V-BELT	—	—	18-15400
	7.4L	440 TRS	1983-1986	454	8	4	4179554 - B485220	V-BELT	18-15480	—	—
	7.4L	450	1995-1996	454	8	4	F347100 - F347277	V-BELT	—	—	18-15400
	7.4L	454 MAG ALPHA	1986-1988	454	8	4	A631894 - B785148	V-BELT	18-15470	18-15500 (50° BELT)	—
	7.4L	454 MAG ALPHA	1986-1988	454	8	4	A631894 - B785148	V-BELT	18-15470	18-15550 (55° BELT)	—
	7.4L	454 MAG	1988-92	454	8	4	B721206 - D805068		18-15470	18-15550	18-15290
	7.4L	454 MAG	1988-92	454	8	4	B721206 - D805068		18-15480	—	18-15290
	7.4L	454 MAG	1992-97	454	8	4	D805069 - K999999		18-15480	—	18-15400

- (1) 1/2" wide (13mm) belt
- (2) 3/8" wide (10mm) belt
- (3) 28" wide (711mm) belt
- (4) 30" wide (762mm) belt
- (5) 37" wide (940mm) belt
- (6) 40" wide (1016mm) belt
- (7) 50" wide (1270mm) belt
- (8) 55" wide (1397mm) belt

- (9) Use with 5 1/2" (140mm) dia water pump pulley
- (10) Use with 5 7/8" (149mm) dia water pump pulley
- (11) Use with 7" (178mm) dia water pump pulley
- (12) Use with stamped steel sea water pump pulley
- (13) Use with cast aluminum sea water pump pulley
- (14) Use with plastic 4 3/4" (121mm) dia p/s pump pulley
- (15) Use with metal 5 3/4" (146mm) dia p/s pump pulley
- (16) For engine with high mounted p/s pump

- (17) For engines with low mounted p/s pump
- (18) For engine with power steering
- (19) For engines w/o power steering
- (20) For engines with closed cooling
- (21) For engines with standard cooling
- (22) Replacement kit includes 5 3/4" (146mm) pulley and longer serpentine belt
- (23) For engines with high mounted alternator

V-BELT APPLICATION

HP	Liter	Model	Years	CID	# Cyl	Stroke	Serial #	Belt Type	Alternator/ Water Pump	Power Steering	Sea Water Pump
	7.4L	454 MAG MPI	1994-97	454	8	4	F115700 - K147349		18-15480	—	18-15400
	7.4L	454 MAG MPI	1997	454	8	4	K147350 - K999999		18-15480	—	18-15290
	7.4L	454 MAG Ski	1995-97	454	8	4	F215800 - K999999		18-15480	—	18-15400
	7.4L	454 MAG BRAVO	1988-1992	454	8	4	B721206 - D805068	V-BELT	18-15470 (9)	18-15550 (9)	18-15290
	7.4L	454 MAG BRAVO	1988-1992	454	8	4	B721206 - D805068	V-BELT	18-15480 (11)	— (11)	18-15290
	7.4L	454 MAG BRAVO	1992-1997	454	8	4	D805069 - K999999	V-BELT	18-15480	—	18-15400
	7.4L	454 MAG EFI	1994-1996	464	8	4	F115700 - F802349	V-BELT	18-15480	—	18-15400
	7.4L	454 MAG EFI SKI	1995-1996	454	8	4	F215800 - F820099	V-BELT	18-15480	—	18-15400
	7.4L	454 MAG MPI	1996-1997	454	8	4	F115700 - F147349	V-BELT	18-15480	—	18-15400
	7.4L	454 MAG MPI	1997	454	8	4	K147350 - K999999	V-BELT	18-15480	—	18-15290
	7.4L	525 SC	1991-1999	454	8	4	D456000 - L415623	V-BELT	—	18-15500	18-15400
	7.4L	7.4L BRAVO	1988-1991	454	8	4	B771113 - D803117	V-BELT	18-15470	18-15550 (9)	18-15290
	7.4L	7.4L BRAVO	1988-1991	454	8	4	B771113 - D803117	V-BELT	18-15480	— (11)	18-15290
	7.4L	7.4L BRAVO	1992-1997	454	8	4	D603118 - K999999	V-BELT	18-15480	—	18-15400
	7.4L	7.4L MIE (WITH B/W)	1988-1992	454	8	4	B788366 - D715493	V-BELT	18-15470	—	18-15290
	7.4L	7.4L MIE (WITH B/W)	1988-1992	454	8	4	B788366 - D715493	V-BELT	18-15470	—	18-15400
	7.4L	7.4L MIE (WITH HURTH)	1989-1992	454	8	4	C391564 - D715493	V-BELT	18-15470 (10)	—	18-15290 (12)
	7.4L	7.4L MIE (WITH HURTH)	1989-1992	454	8	4	C391564 - D715493	V-BELT	18-15480 (11)	—	18-15290 (13)
	7.4L	7.4L MIE	1992-1997	454	8	4	D715494 - K999999	V-BELT	18-15480	—	18-15400
	7.4L	7.4L MPI	1998-2001	454	8	4	L010003 - M024330	SERPENTINE	18-15114 (14, 22)	—	—
	7.4L	7.4L MPI	1998-2001	454	8	4	L010003 - M024330	SERPENTINE	18-15114 (14)	—	—
	7.4L	7.4L MPI / 7.4L MIE	1995-1996	454	8	4	F563052 - F820131	V-BELT	18-15480	—	18-15400
	7.4L	7.4L MPI / 7.4L MIE	1996-1997	454	8	4	F820132 - K999999	V-BELT	18-15480	—	18-15290
	7.4L	7.4LX BRAVO EFI	1996-1997	454	8	4	F820000 - K999999	V-BELT	18-15480	—	18-15290
	7.4L	7.4LX BRAVO MPI	1996-1997	454	8	4	F602010 - K147349	V-BELT	18-15480	—	18-15400
	7.4L	7.4LX BRAVO MPI	1997	454	8	4	K147350 - K999999	V-BELT	18-15480	—	18-15290
	7.4L	7.4LX Bravo MPI	1996-97	454	8	4	F602010 - K147349		18-15480	—	18-15400
	7.4L	7.4L MIE	1992-97	454	8	4	C391564 - K999999		18-15480	—	18-15400
	7.4L	370 TRS	1978-85		8	4	4179554 - 6721527		18-15480	—	—
	7.4L	370 TRS	1985-87		8	4	6721528 - B714586		18-15480	18-15500	—
		390 MCM / 390 MIE	1969-1970	482	8	4	2781129 - 3042731	V-BELT	18-15480	—	—
		400 TRS	1983-1986	482	8	4	4179554 - 6181046	V-BELT	18-15480	—	—
		420/425	1987-1992		8	4	A398941 - D725499		18-15480	18-15500	—
		420 / 425	1992		8	4	D725500 - D937011		18-15480	—	18-15400
		440 TRS	1983-1986		8	4	4179554 - B485220		18-15480	—	—
		450	1995-1996		8	4	F347100 - F347227		18-15480	—	18-15400
		460 TRS	1983-1986		8	4	4179554 - 6181046		18-15480	—	—
		465	1990-1992	502	8	4	C849992 - D725646	V-BELT	—	—	18-15290
	8.2L	465	1992-1994	502	8	4	D725647 - F213244	V-BELT	—	—	18-15400
	8.2L	500	1994-1998	502	8	4	F213293 - L001772	V-BELT	—	—	18-15400
	8.2L	500 GEN +	1999	502	8	4	L414639 - L601036	V-BELT	—	—	18-15400
	8.2L	502 MAG BRAVO	1990-1997	502	8	4	C878221 - D824588	V-BELT	18-15480	—	18-15290
	8.2L	502 MAG BRAVO	1990-1997	502	8	4	C824589 - K999999	V-BELT	18-15480	—	18-15400
	8.2L	502 MAG EFI	1994-1995	502	8	4	D840650 - F802599	V-BELT	18-15480	—	18-15400
	8.2L	502 MAG MPI	1996-1997	502	8	4	F802600 - K147349	V-BELT	18-15480	—	18-15400
	8.2L	502 MAG MPI	1997	502	8	4	K147350 - K999999	V-BELT	18-15480	—	18-15290
	8.2L	502 MAG MPI	1998-2001	502	8	4	L017000 - M024999	SERPENTINE	18-15114 (14, 22)	—	—
	8.2L	502 MAG MPI	1998-2001	502	8	4	L017000 - M024999	SERPENTINE	18-15114 (14)	—	—
	8.2L	600 SC	1991-1992	502	8	4	D456489 - D456768	V-BELT	—	18-15500	18-15345
	8.2L	600 SC	1992-2000	502	8	4	D725676 - L601186	V-BELT	—	18-15500	18-15400
	8.2L	8.2L MIE	1990-1993	502	8	4	C878221 - D857199	V-BELT	18-15480	—	18-15290
	8.2L	8.2L MIE	1993-1997	502	8	4	D857200 - K999999	V-BELT	18-15480	—	18-15400
	8.2L	8.2L MPI MIE	1996-1997	502	8	4	F819620 - K147349	V-BELT	18-15480	—	18-15400
	8.2L	8.2L MPI MIE	1997	502	8	4	K147350 - K999999	V-BELT	18-15480	—	18-15290
	8.2L	500 BULDOG	1990-2001	540	8	4	C577254 - M050281	V-BELT	— (3/8" BELT WIDTH)	—	18-15345
	8.2L	500 BULDOG	1990-2001	540	8	4	C577254 - M050281	V-BELT	— (1/2" BELT WIDTH)	—	18-15345

- (1) 1/2" wide (13mm) belt
- (2) 3/8" wide (10mm) belt
- (3) 28" wide (711mm) belt
- (4) 30" wide (762mm) belt
- (5) 37" wide (940mm) belt
- (6) 40" wide (1016mm) belt

- (7) 50" wide (1270mm) belt
- (8) 55" wide (1397mm) belt
- (9) Use with 5 1/2" (140mm) dia water pump pulley
- (10) Use with 5 7/8" (149mm) dia water pump pulley
- (11) Use with 7" (178mm) dia water pump pulley
- (12) Use with stamped steel sea water pump pulley

- (13) Use with cast aluminum sea water pump pulley
- (14) Use with plastic 4 3/4" (121mm) dia p/s pump pulley
- (15) Use with metal 5 3/4" (146mm) dia p/s pump pulley
- (16) For engine with high mounted p/s pump
- (17) For engines with low mounted p/s pump
- (18) For engine with power steering

- (19) For engines w/o power steering
- (20) For engines with closed cooling
- (21) For engines with standard cooling
- (22) Replacement kit includes 5 3/4" (146mm) pulley and longer serpentine belt
- (23) For engines with high mounted alternator

SERPENTINE BELTS



BELT INTERCHANGE

Part No.	OE #	Width	Length (in.)	Part No.	OE #	Width	Length (in.)
18-15100	57-8638763, 57-862807, 57-862087A1, 57-865615003, 57-865615Q03	13/16	106.25	18-15114	57-861049, 57-861049Q	13/16	104.25
18-15101	57-8638764, 57-862086, 57-8620861, 57-862086A1, 57-865615004, 57-865615Q04	13/16	76.5	18-15115	57-861757, 57-861757Q	13/16	97.5
18-15102	57-8638766, 57-8610491, 57-865615006, 57-865615Q06	13/16	105	18-15116	57-861758, 57-861758Q	13/16	86.75
18-15103	57-8638767, 57-865615007, 57-861050, 57-865615Q07	13/16	96.75	18-15117	57-861759	13/16	92.5
18-15104	57-8638768, 57-862089, 57-862089A1, 57-865615008, 57-865615Q08	13/16	99.5	18-15119	57-8638761, 57-8623523, 57-865615001, 57-865615Q01	13/16	111.25
18-15105	57-8638769, 57-865615009, 57-862088, 57-862088A1, 57-865615Q09	13/16	69.75	18-15121	57-865615005, 57-865615Q05, 57-8638765, 57-865423005	13/16	87.5
18-15112	57-8077554, 57-807755Q04	13/16	88	18-15122	57-865615010, 57-86387610, 57-865615Q10	13/16	86
18-15113	57-8077555	13/16	75.75	18-15123	57-864639	13/16	85
				18-15124	57-881754	1-1/16	55.75
				18-15125	57-817113	1 3/8	53.5

BELT APPLICATION

Engine	Years	Serial #	Part #	Mercruiser #	Foothole	Engine	Years	Serial #	Part #	Mercruiser #	Foothole
4.3L Alpha	1996-99	OF803000-OL618999	18-15116	57-861758	2, 6	5.7L Alpha	1997-99	OK001506-OL618999	18-15116	57-861758	2, 6
4.3L Alpha	2000-04	OL619000 & up	18-15101	57-863876 4	3, 6, 7	5.7L Alpha	2000-04	OL619000 & up	18-15101	57-863876 4	3, 6, 7
4.3L Alpha	2000-04	OL619000 & up	18-15104	57-863876 8	4, 5, 7	5.7L Alpha	2002-04	OM600000 & up	18-15102	57-863876 6	3, 5, 7
4.3L Alpha	2000-04	OL619000 & up	18-15105	57-865615009	4, 6, 7	5.7L Alpha	2000-04	OL619000 & up	18-15104	57-863876 8	4, 5, 7
4.3L Bravo	1996-99	OF803000-OL618999	18-15114	57-861049	2, 5	5.7L Alpha	2000-05	OL619000 & up	18-15105	57-865615009	4, 6, 7
4.3L Bravo	1996-99	OF803000-OL618999	18-15115	57-861757	2, 6	5.7L Bravo	1997-99	OK001506-OL618999	18-15114	57-861049	2, 5
4.3L Bravo	2000-04	OL619000 & up	18-15104	57-863876 8	4, 7	5.7L Bravo	1997-99	OK001506-OL618999	18-15115	57-861757	2, 6
5.0L Bravo	2002-04	OM600000 & up	18-15102	57-863876 6	3, 5, 7	5.7L Bravo	2002-04	OM600000 & up	18-15102	57-863876 6	3, 5, 7
5.0L Alpha	1998-99	OL012052-OL618999	18-15114	57-861049	5	5.7L Bravo	2000-04	OL619000 & up	18-15104	57-863876 8	4, 7
5.0L Alpha	1998-99	OL012052-OL618999	18-15116	57-861758	2, 6	5.7L Ski	1997-02	OK040004-OM316999	18-15112	57-8077554	
5.0L Alpha	2000-04	OL619000 & up	18-15101	57-863876 4	3, 6, 7	5.7L Ski	2002-05	OM317000 & up	18-15121	57-865615005	
5.0L Alpha	2002-04	OM600000 & up	18-15102	57-863876 6	3, 5, 7	5.7L MIE	2001-05	OL677227 & up	18-15121	57-865615005	
5.0L Alpha	2001-04	OL619000 & up	18-15104	57-863876 8	4, 5, 7	377 Scorpion MCM	1999-04	OL416146 & up	18-15115	57-861757	
5.0L Alpha	2000-04	OL619000 & up	18-15105	57-865615009	4, 6, 7	377 Scorpion Ski	1997-98	OK000656 & up	18-15112	57-8077554	
5.0L Bravo	1998-99	OL012052-OL618999	18-15114	57-861049	2, 5	454 Mag MPI	1998-01	OL010029-OM024999	18-15114	57-861049	1
5.0L Bravo	1998-99	OL012052-OL618999	18-15115	57-861757	2, 6	454 Mag MPI	1998-01	OL010029-OM024999	18-15102	57-863876 6	2
5.0L Bravo	2000-04	OL619000 & up	18-15104	57-863876 8	4, 7	454 Mag MPI	1998-01	OL010029-OM024999	18-15103	57-865615007	4
350 Mag, Alpha	1997-04	OK001501-OL618999	18-15114	57-861049	2, 5	454 Mag MPI Horizon MIE	1998-01	OL002200-OL674000	18-15103	57-865615007	
350 Mag, Alpha	1997-04	OK001501-OL618999	18-15116	57-861758	2, 6	496 Mag & HO	2000-04	OM025000 & up	18-15119	57-863876 1	
350 Mag, Alpha	2000-04	OL619000 & up	18-15103	57-865615007	3, 6, 7	500 EFI	1999-04	OL001477 & up	18-15112	57-8077554	
350 Mag, Alpha	2002-04	OM600000 & up	18-15102	57-863876 6	3, 5, 7	502 Mag MPI	1998-01	OL017000-OM024999	18-15114	57-861049	1
350 Mag, Alpha	2000-04	OL619000 & up	18-15104	57-863876 8	4, 5, 7	502 Mag MPI	1998-01	OL017000-OM024999	18-15103	57-865615007	4
350 Mag, Alpha	2000-04	OL619000 & up	18-15105	57-865615009	4, 6, 7	502 Mag, MPI	1998-01	OL017000-OM024999	18-15102	57-863876 6	2
350 Mag, Bravo	1997-04	OK001501-OL618999	18-15114	57-861049	2, 5	525 SC	1991-96	OD456000-745215	18-15125	57-817113	
350 Mag, Bravo	1997-04	OK001501-OL618999	18-15115	57-861757	2, 6	575 Sci	2000-05	OL306696 & up	18-15125	57-817113	8
350 Mag, Bravo	2002-04	OM600000 & up	18-15102	57-863876 6	3, 5, 7	575 Sci	2000-05	OL306696 & up	18-15112	57-8077554	9
350 Mag, Bravo	2000-04	OL619000 & up	18-15104	57-863876 8	4, 7	600 SC	1991-96	OD456489-OF877462	18-15125	57-817113	
350 Mag MPI MIE	2001-05	OL678399-up	18-15121	57-865615005	6	600 SC	1998	OK000227 & up	18-15125	57-817113	
350 Mag MPI MIE	2002-05	OM317000 & up	18-15122	57-865615010	5	7.4L MPI	1998-01	OL010003-OM024330	18-15114	57-861049	1
350 Mag MPI Ski	2001-05	OM300000 & up	18-15121	57-865615005		7.4L MPI	1998-01	OL010003-OM024330	18-15102	57-863876 6	2
350 Mag MPI Horizon MIE	2001-02	OL678399-OM316999	18-15121	57-865615005		7.4L MPI	1998-01	OL010003-OM024330	18-15103	57-865615007	4
350 Mag MPI Horizon MIE	2001-05	OM317000 & up	18-15122	57-865615010		7.4L MPI MIE	1998-01	OL002006-OM025999	18-15103	57-865615007	
5.7L Alpha	1997-99	OK001501-OL618999	18-15114	57-861049	2, 5	Black Scorpion Ski	1997-01	OK040001-OM391599	18-15112	57-8077554	

Footnotes

- 1: Use with plastic 4-3/4" dia. p/s pump pulley
- 2: Use with metal 5-3/4" dia. p/s pump pulley
- 3: For engines with power steering

- 4: For engines without power steering
- 5: For engines with closed cooling
- 6: For engines with standard cooling

- 7: Engines with high mounted alternators
- 8: Blower
- 9: Alternator

BELT APPLICATION

Engine	Years	Serial #	Part #	Mercruiser #	Foothole	Engine	Years	Serial #	Part #	Mercruiser #	Foothole
Black Scorpion Ski	2003-05	OM391600 & up	18-15121	57-865615005		MX 6.2L MPI Horizon MIE	2001-05	OM310100 & up	18-15121	57-865615005	6
MX 6.2L Blk Scorpion Ski	2001	OL670015-OM391599	18-15112	57-8077554		MX 6.2L MPI Horizon MIE	2002-05	OM317000 & up	18-15122	57-865615010	5
MX 6.2L MPI	2002-04	OM600000 & up	18-15102	57-863876 6	3, 5	MX 6.2L MPI MIE	1999-01	OL670000-OM310099	18-15112	57-8077554	
MX 6.2L MPI	2000-04	OL680003 & up	18-15104	57-863876 8	4, 7	MX 6.2L MPI MIE	2001-05	OM310100 & up	18-15121	57-865615005	6
MX 6.2L MPI Horizon	2002-04	OM600000 & up	18-15102	57-863876 6	3	MX 6.2L MPI MIE	2002-05	OM317000 & up	18-15122	57-865615010	5
MX 6.2L MPI Horizon	2001-04	OM300000 & up	18-15104	57-863876 8	4	MX 6.2L MPI Ski	2002-05	OM317000 & up	18-15121	57-865615005	
MX 6.2L MPI Horizon MIE	2001	OM300000-OM310099	18-15112	57-8077554		8.2L MPI MIE	1998-01	OL002450-OL674200	18-15103	57-865615007	

Footnotes

- 1: Use with plastic 4-3/4" dia. p/s pump pulley
- 2: Use with metal 5-3/4" dia. p/s pump pulley
- 3: For engines with power steering
- 4: For engines without power steering

- 5: For engines with closed cooling
- 6: For engines with standard cooling
- 7: Engines with high mounted alternators
- 8: Blower
- 9: Alternator

Fits GM Big Block V8 454 cu. in. Models 330, 340 & 7.4L

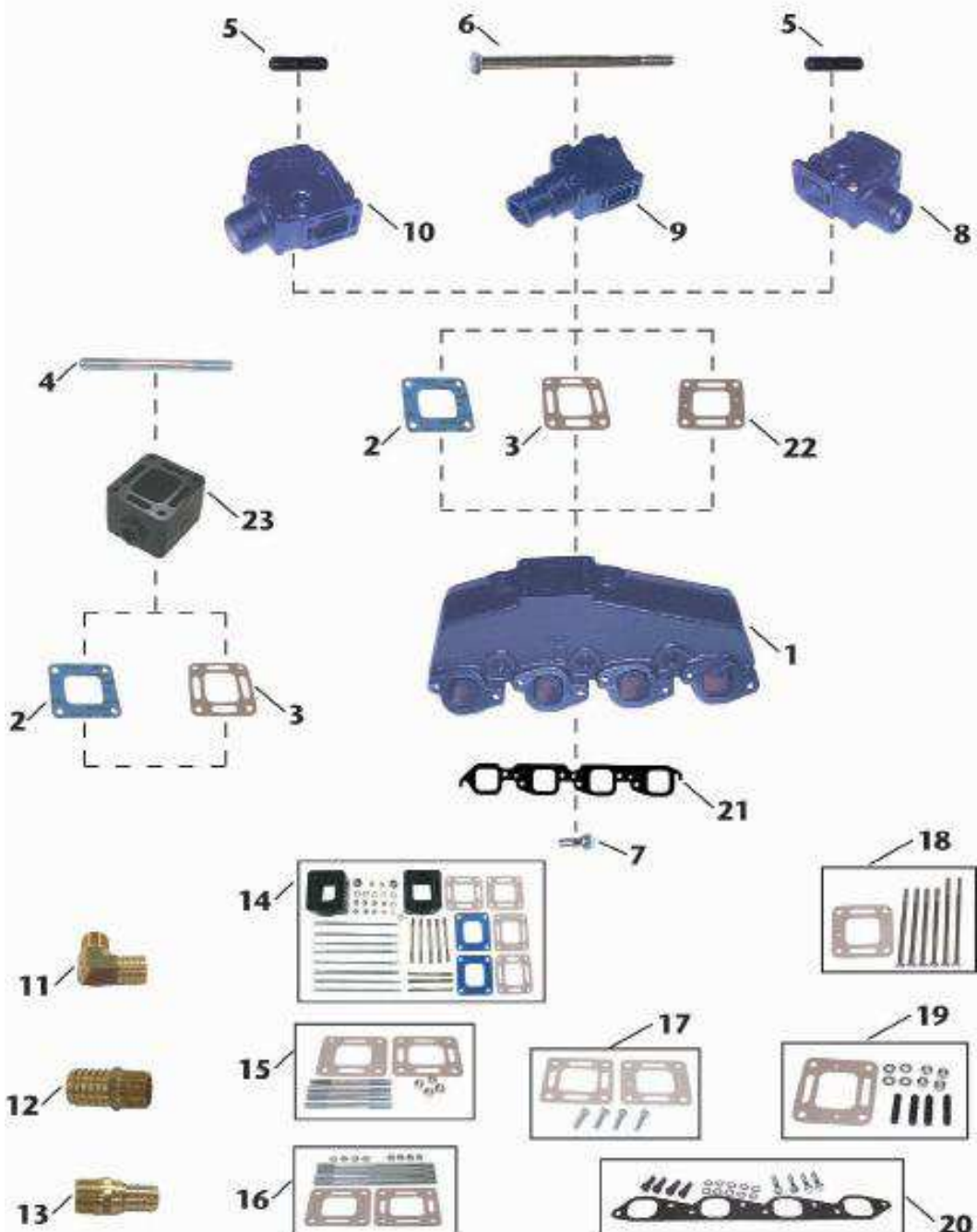

SEE NEXT PAGE FOR CHART

Item No.	Description	OE No.	Application	
1	18-1957-2	MANIFOLD	807078A6	GM Big Block (V8) 454 cu.in. Models 330, 340 & 7.4L. Use with 18-0418 manifold gasket; Mounting Kit: 18-8532
2	18-0672 (blocked)	ELBOW GASKET (Blocked)	27-860231	Fits Manifold: 18-1957-2 ; Elbows: 18-1970-2 , & 18-1976-2 , 18-1974 ; Spacer 18-1908
3	18-2849-1	ELBOW GASKET (Open)	27-818832	Fits Manifold: 18-1957-2 ; Elbows: 18-1970-2 , & 18-1976-2 , 18-1974 ; Spacer 18-1908
4	NSS	MOUNTING STUD	N/A	Included in 18-8554 mounting kit
5	NSS	MOUNTING STUD	N/A	Included in 18-8529 mounting kit
6	NSS	MOUNTING BOLT	N/A	Included in 18-8505 mounting kit
7	NSS	MOUNTING BOLT	N/A	Included in 18-8532 mounting kit
8	18-1974-1	MANIFOLD ELBOW (3" hose • 15° down angle)	98502A2	Fits Manifold: 18-1957-2 . Use Elbow gaskets: 18-2849-1 , 18-0897 , or 18-0672 ; Use mounting kit: 18-8529 (Do not use with spacer)
9	18-1976-2	MANIFOLD ELBOW (4" hose • 7° down angle)	44354A3	Fits Manifold: 18-1957-2 . Use Elbow gaskets: 18-2849-1 , 18-0897 , or 18-0672 ; Use mounting kit: 18-8505 , or if spacer is included use 18-8555
10	18-1970-2	MANIFOLD ELBOW (3" hose)	98504A3	Fits Manifold: 18-1957-2 . Use Elbow gaskets: 18-2849-1 , 18-0897 , or 18-0672 ; Use mounting kit: 18-8529 , or if spacer is included use 18-8554
11	18-8216	HOSE FITTING	N/A	3/4" - 14NPT X 1" Hose (Corrosion Resistant Brass Fitting)
12	18-4461	HOSE FITTING	N/A	3/4" - 14NPT X 1" Hose (Corrosion Resistant Brass Fitting)
13	18-8215	HOSE FITTING	N/A	3/4" - 14NPT X 3/4" Hose (Corrosion Resistant Brass Fitting)
14	18-1908K	MANIFOLD SPACER KIT	807476A6, 93320A5	3" Riser Kit for Manifold: 18-1957-2 . Includes (2) spacers, restrictor, open, & blocked gasket. All necessary mounting hardware is also included
15	18-8554	MOUNTING KIT	N/A	Use 18-8554 Mounting Kit when 18-1908 Spacer, 18-1970-2 Elbow and 18-1974 Elbow are used together. Included in 18-1908K . Includes (1) 18-2849-1 & 18-0897 elbow gaskets
16	18-8555	MOUNTING KIT	N/A	Use with Manifold Spacer: 18-1908 with Riser 18-1976-2 . Included in 18-1908K . Includes (1) 18-2849-1 & 18-0897 elbow gaskets.
17	18-8556	MOUNTING KIT	N/A	Use with Manifold Spacer: 18-1985 . Includes (1) 18-2849-1 & 18-0897 elbow gaskets
18	18-8505	MOUNTING KIT	N/A	Use with Riser: 18-1976-2 . Includes 18-0897 elbow gasket
19	18-8529	MOUNTING KIT	N/A	Use with Risers: 18-1970-2 & 18-1974-1 . Includes 18-0897 elbow gasket
20	18-8532	MOUNTING KIT	N/A	Use with Manifold: 18-1957-2 . Includes 18-0418 manifold gasket
21	18-0418	MANIFOLD GASKET	96653 / 27-41813	Use with Manifold: 18-1957-2 . Included in 18-8532 mounting kit.
22	18-0897	ELBOW GASKET (Restrictor)	27-41813	Fits Manifold: 18-1957-2 ; Manifold Spacers: 18-1985 , & 18-1908 ; Elbows: 18-1970-2 , & 18-1976-2 , 18-1974
23	18-1908	MANIFOLD SPACER	93322A12	3" Spacer for Manifold: 18-1952-1 . Use with mounting kit 18-8556 (Note: To mount elbows to spacer a separate mounting kit is needed)



**Fits GM In-Line 6 Cylinder 250 & 292 cu. in.
Models 165 & 200**

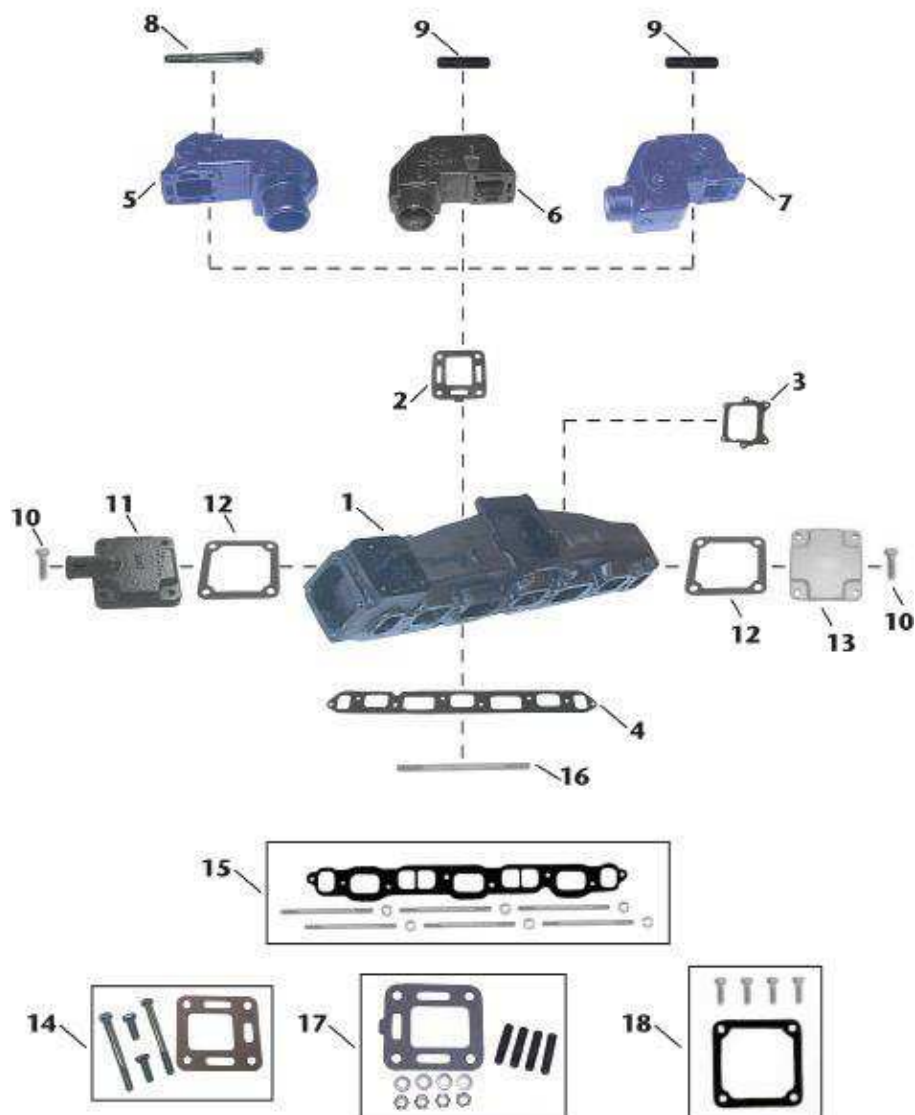

Item No.	Description	OE No.	Application
1	18-1960-1 MANIFOLD	58759A10	GM In-Line Six Cylinder 250 & 292 cu.in. Models 165 & 200. Use with 18-2830-1 manifold gasket; 18-8531 Mounting Kit
2	18-2833 ELBOW GASKET	27-99777-2	Use with Elbows: 18-1971 , 18-1978 & 18-1972 . Included in 18-4362 mounting kit
3	18-0353 CARBURETOR GASKET	27-58764	Fits Manifold: 18-1960-1
4	18-2830-1 MANIFOLD GASKET	27-46401	Fits Manifold: 18-1960-1 . Included in 18-8531 mounting kit.
5	18-1972 MANIFOLD ELBOW	76325A2	Use with Manifold: 18-1960-1 ; Elbow Gasket 18-2833
6	18-1971 MANIFOLD ELBOW	76351A2	Use with Manifold: 18-1960-1 ; Elbow Gasket 18-2833 ; Mounting Kit 18-4362
7	18-1978 MANIFOLD ELBOW	76771A3	Use with Manifold: 18-1960-1 ; Elbow Gasket 18-2833 ; Mounting Kit 18-4362
8	NSS MOUNTING BOLT	N/A	Included in 18-8552 mounting hardware
9	18-3233 MOUNTING STUD	16-49545	3/8-24, 3/8-16 X 1 3/4. Included in 18-4362 mounting kit.
10	NSS MOUNTING BOLT	N/A	Included in 18-8512 mounting kit.
11	18-4009 FRONT PLATE	60252A2	Fits Manifold: 18-1960-1
12	18-2832-1 FRONT/END PLATE GASKET	27-48043-1	Fits Port & Starboard Caps of Manifold: 18-1960-1 . Included in 18-8512 mounting kit
13	NSS END PLATE	N/A	Fits Manifold: 18-1960-1
14	18-8552 HARDWARE KIT	N/A	Includes only hardware for 18-1972 elbow.
15	18-8531 MOUNTING KIT	N/A	Use with Manifold: 18-1960-1 . Includes 18-2830-1 manifold gasket.
16	NSS MOUNTING STUD	N/A	Included in 18-8531 mounting kit
17	18-4362 MOUNTING KIT	N/A	Use with Elbows: 18-1971 & 18-1978 . Includes 18-2833 elbow gasket
18	18-8512 MOUNTING KIT	N/A	Use with Front Plate: 18-4009 . Includes 18-2832-1 gasket

Fits GM V6 229 & 262 cu. in. Models 185 & 205

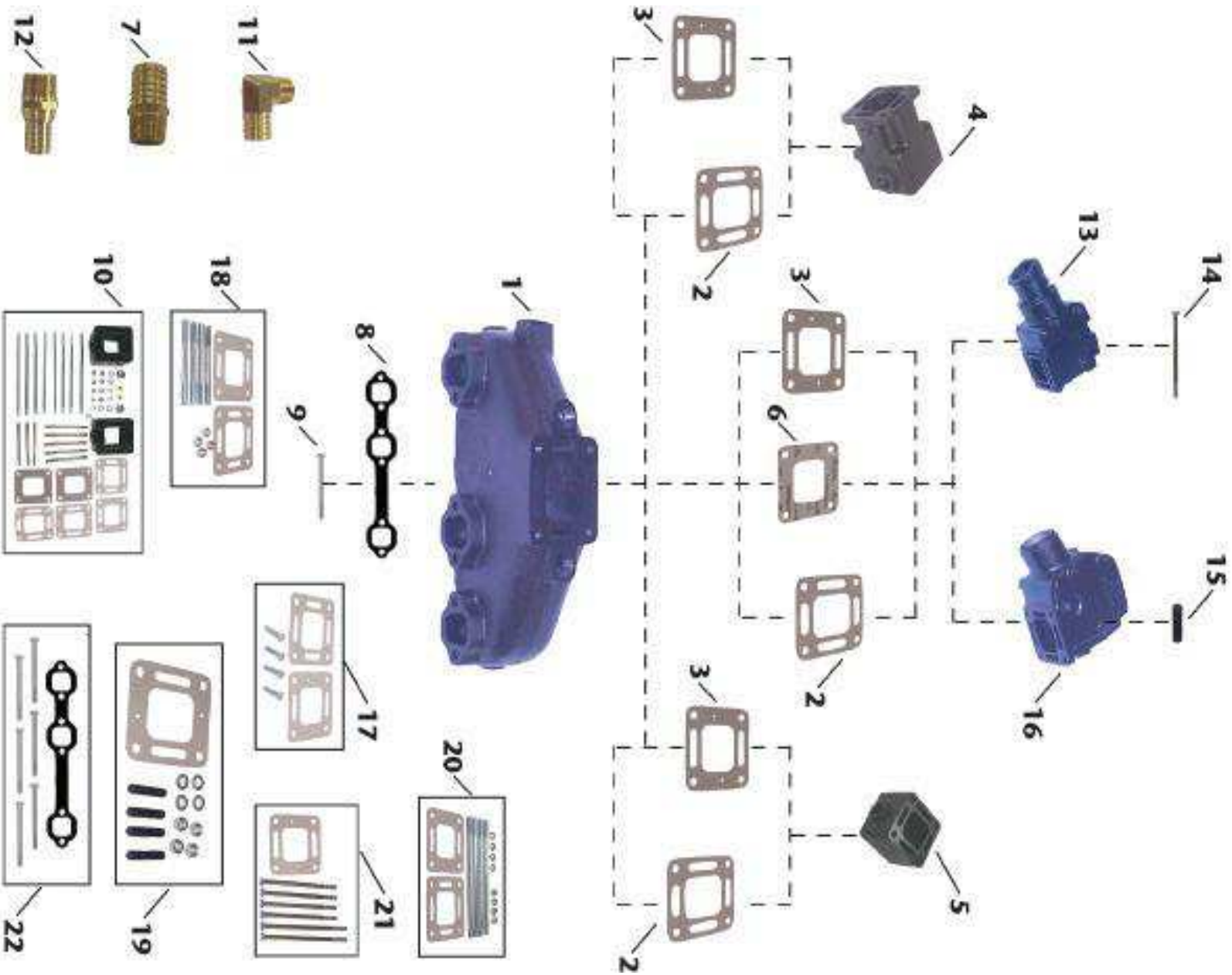

Item No.	Description	OE No.	Application	
1	18-1952-1	MANIFOLD	99746A8	GM (V6) 229 & 262 cu.in. Models 185 & 205 (Port & Starboard). Use with Manifold Gasket: 18-2909; Mounting Kit: 18-8533.
2	18-2849-1	ELBOW GASKET (OPEN)	27-818832	Fits Manifold: 18-1952-1; Manifold Spacers: 18-1985, & 18-1908; Elbows: 18-1970-2, & 18-1976-2
3	18-0897	ELBOW GASKET (RESTRICTOR)	27-41813	Fits Manifold: 18-1952-1; Manifold Spacers: 18-1985, & 18-1908; Elbows: 18-1970-2, & 18-1976-2
4	18-1985	MANIFOLD SPACER	93322A12	6" Spacer for Manifold: 18-1952-1. Use with mounting kit 18-8556. (Note: To mount elbows to spacer a separate mounting kit is required)
5	18-1908	MANIFOLD SPACER	933220	3" Spacer for Manifold: 18-1952-1. Use with mounting kit 18-8555 with 18-1976-2, or mounting kit 18-8554 with 18-1970-2.
6	18-0672	ELBOW GASKET (BLOCKED)	27-860231	Fits Manifold: 18-1952-1; Elbows: 18-1970-2, & 18-1976-2
7	18-4461	HOSE FITTING	N/A	3/4" - 14NPT X 1" Hose (Corrosion Resistant Brass Fitting)
8	18-2909	MANIFOLD GASKET	N/A	Gasket for Manifold: 18-1952-1. Included in 18-8533 mounting kit.
9	NSS	MOUNTING BOLT	N/A	Included in 18-8533 mounting kit.
10	18-1908K	MANIFOLD SPACER KIT	807476A6, 93320A5	3" Riser Kit for Manifold: 18-1952-1. Includes (2) spacers, restrictor, open, & blocked gasket. All necessary mounting hardware is also included.
11	18-8216	HOSE FITTING	N/A	3/4" - 14NPT X 1" Hose (Corrosion Resistant Brass Fitting)
12	18-8215	HOSE FITTING	N/A	3/4" - 14NPT X 3/4" Hose (Corrosion Resistant Brass Fitting)
13	18-1976-2	MANIFOLD ELBOW (4" hose • 7° down angle)	44354A3, 807914A1	Fits Manifold: 18-1952-1. Use Elbow gaskets: 18-2849-1, 18-0897, or 18-0672; Use mounting kit: 18-8554
14	NSS	MOUNTING BOLT	N/A	Included in 18-8505 mounting kit.
15	NSS	MOUNTING STUD	N/A	Included in 18-8529 mounting kit.
16	18-1970-2	MANIFOLD ELBOW (3" hose • 0° down angle)	98504A3	Fits Manifold: 18-1952-1. Use Elbow gaskets: 18-2849-1, 18-0897, or 18-0672; Use mounting kit: 18-8529, or if spacer is included use 18-8555
17	18-8556	MOUNTING KIT	N/A	Use with Manifold Spacer: 18-1985. Includes (1) 18-2849-1 & 18-0897
18	18-8554	MOUNTING KIT	N/A	Use with Manifold Spacer: 18-1908 with Riser 18-1970-2. Included in 18-1908K. Includes (1) 18-2849-1 & 18-0897 elbow gaskets.
19	18-8529	MOUNTING KIT	N/A	Use with Riser: 18-1970-2. Includes 18-0897 elbow gaskets
20	18-8555	MOUNTING KIT	N/A	Use with Manifold Spacer: 18-1908 with Riser 18-1976-2. Included in 18-1908K. Includes (1) 18-2849-1 & 18-0897 elbow gasket.
21	18-8505	MOUNTING KIT	N/A	Use with Riser: 18-1976-2. Includes 18-0897 elbow gasket.
22	18-8533	MOUNTING KIT	N/A	Use with Manifold: 18-1952-1. Includes 18-2909 manifold gasket.



**Fits GM Small Block V8 305-350 cu. in.
Models 198, 228 & 898**

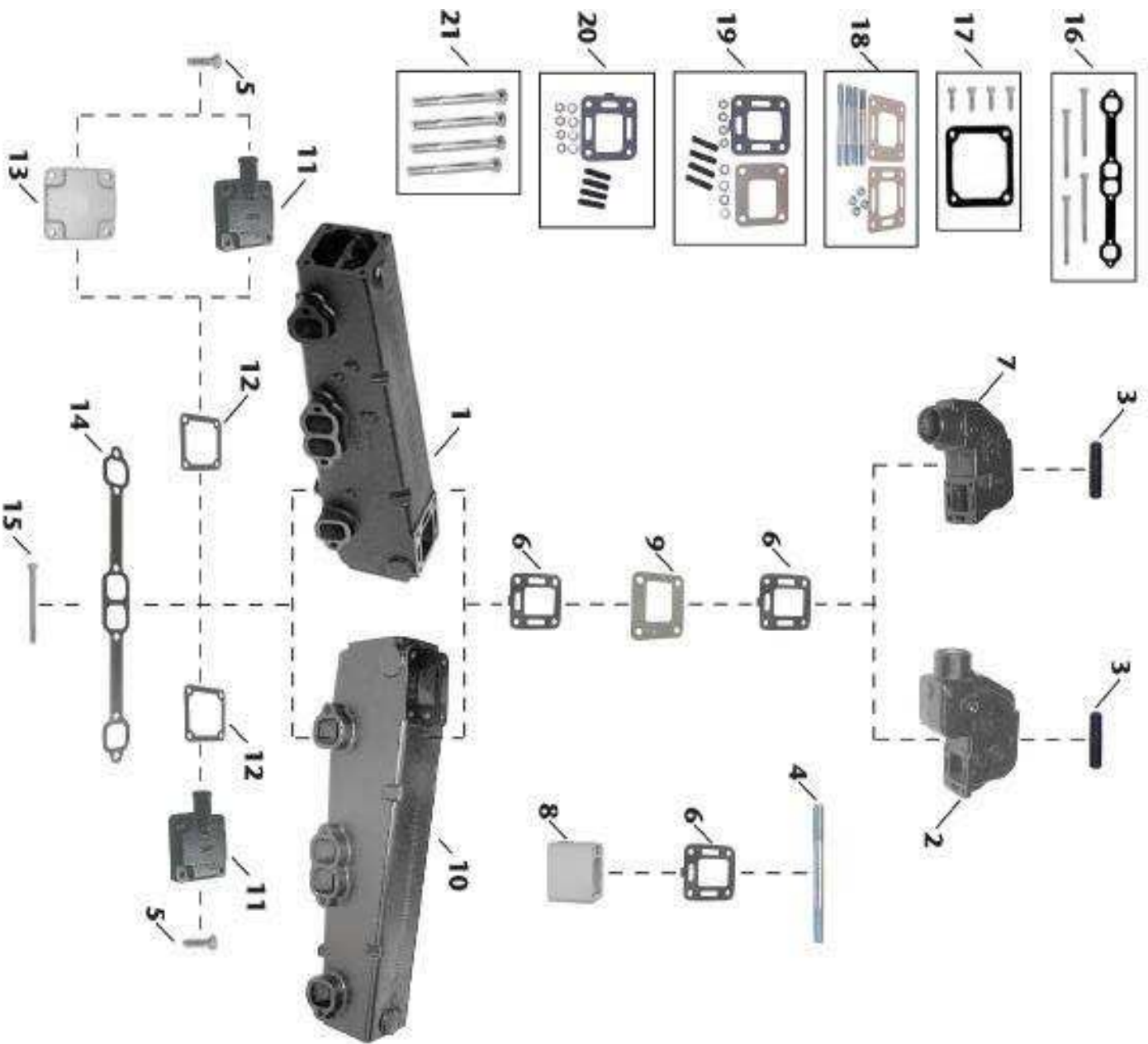

Item No.	Description	OE No.	Application	
1	18-1951-1	MANIFOLD (STARBOARD)	774235A2	GM Small Block (V8) 305-350 cu.in. Models 198, 228, & 898. (Starboard)
2	18-1978	MANIFOLD ELBOW	76771A3	Use with Manifolds: 18-1950-1, 18-1951-1; Elbow Gasket 18-2833; Mounting Kit 18-4362.
3	18-3233	MOUNTING STUD	16-49545	3/8-24, 3/8-16 X 1 3/4. Included in 18-4362 mounting kit.
4	NSS	MOUNTING STUD	N/A	Included in 18-8554 mounting kit.
5	NSS	MOUNTING BOLT	N/A	Included in 18-8512 mounting kit.
6	18-2833	ELBOW GASKET	27-99777-2	Use with Elbows: 18-1971 & 18-1978. Included in 18-4362 mounting kit.
7	18-1971	MANIFOLD ELBOW	76351A2	Use with Manifolds: 18-1950-1, 18-1951-1; Elbow Gasket 18-2833; Mounting Kit 18-4362.
8	18-1906	MANIFOLD SPACER	61851	3" Spacer for Manifold: 18-1950-1, 18-1951-1. Use with mounting kit 18-8554 with 18-1971 or 18-1978 Elbows.
9	18-4008	BLOCK OFF PLATE	60207	Use with Manifolds 18-1950-1, 18-1951-1. Requires (2) 18-2833 elbow gaskets.
10	18-1950-1	MANIFOLD (PORT)	77234A2	GM Small Block (V8) 305-350 cu.in. Models 198, 228, & 898. (Port)
11	18-4009	END PLATE	60252A2	Use with (Port & Starboard) Manifolds: 18-1950-1 & 18-1951-1; Mounting Kit: 18-8512
12	18-2832-1	FRONT/END PLATE GASKET	27-48043-1	Fits Port & Starboard Caps of Manifolds: 18-1950-1, 18-1951-1. Use with Front Plate: 18-4009. Included in 18-8512 mounting kit.
13	NSS	END PLATE	54870	Fits Manifold: 18-1950-1, 18-1951-1; Mounting Kit: 18-8512.
14	18-2949	MANIFOLD GASKET	96306	Use with Manifold: 18-1951-1
15	NSS	MOUNTING BOLT	N/A	Included in 18-8520 mounting kit.
16	18-8520	MOUNTING KIT	N/A	Use with Manifolds: 18-1950-1, 18-1951-1. Includes 18-2949 manifold gasket.
17	18-8512	MOUNTING KIT	N/A	Use with Front/End Plates: 18-4009. Includes 18-2832-1 front end plate gasket.
18	18-8554	MOUNTING KIT	N/A	Use with Manifold Spacer: 18-1906 with Riser 18-1971 or 18-1978 Elbows. Included in 18-1908K. Includes (1) 18-2849-1 & 18-0897 elbow gaskets.
19	18-8514	MOUNTING KIT	N/A	Use with Elbows: 18-1971 & 18-1978. Includes 18-2833 gasket & 18-4008 block off plate.
20	18-4362	MOUNTING KIT	N/A	Use with Elbows: 18-1971 & 18-1978. Includes 18-2833 elbow gasket.
21	18-8548	HARDWARE KIT	N/A	Includes only hardware for 18-1950-1 & 18-1951-1 manifolds. Included in 18-8520 mounting kit.



**Fits Ford Small Block V8 302-351 cu. in.
Models 215, 225, 233, 255 & 888**

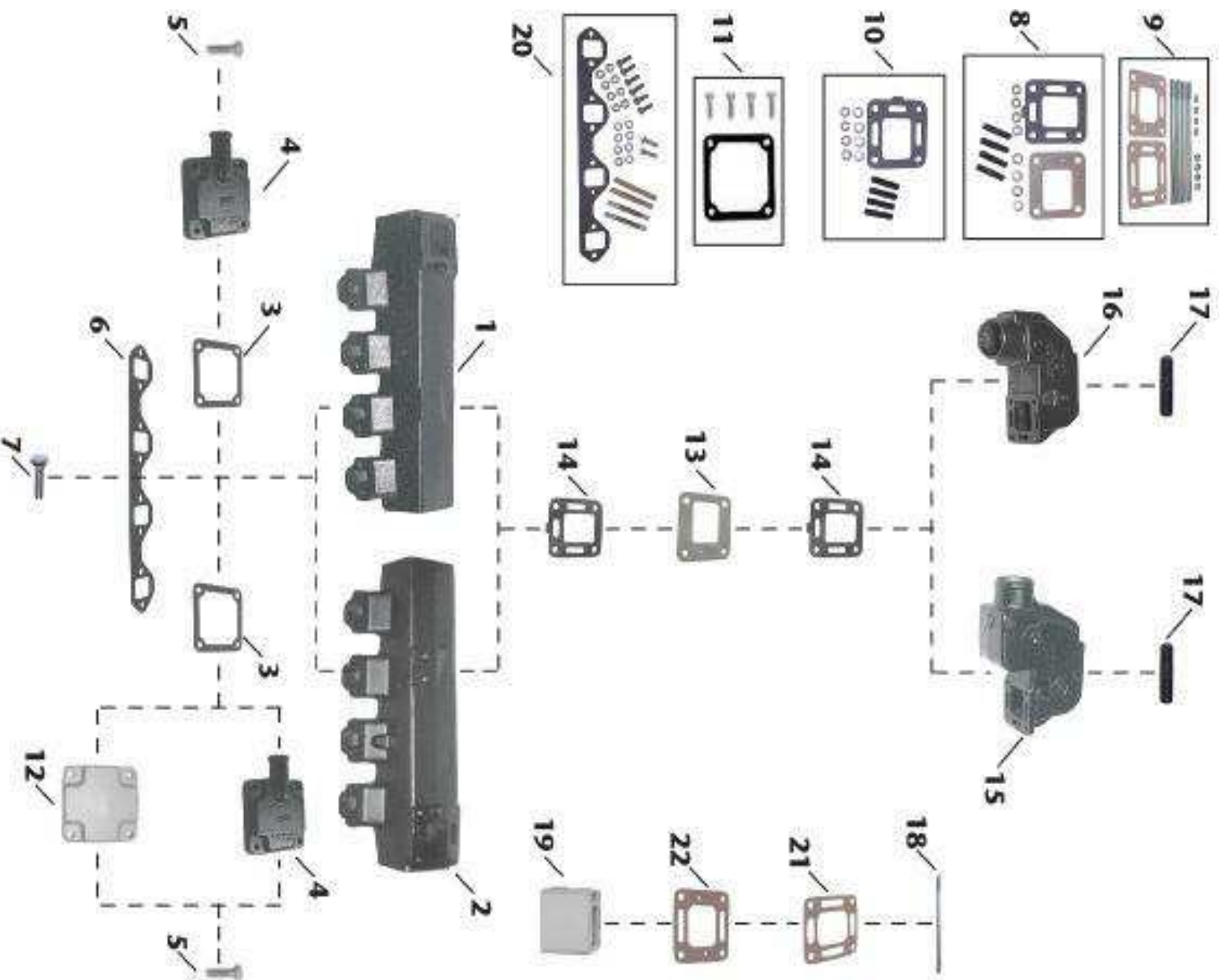

Item No.	Description	OE No.	Application
1	18-1958-1 MANIFOLD (PORT)	65604A4	Ford Small Block (V8) 302-351 cu.in. Models 215, 225, 233, 255, & 888 (Port). Use with Manifold Gasket: 18-0183-1 ; Mounting Kit: 18-8509
2	18-1962-1 MANIFOLD (STARBOARD)	65603A4	Ford Small Block (V8) 302-351 cu.in. Models 215, 225, 233, 255, & 888 (Port). & 888 (Starboard). Use with Manifold Gasket: 18-0183-1 ; Mounting Kit: 18-8509.
3	18-2832-1 FRONT/END PLATE GASKET	27-48043-1	Fits Port & Starboard Caps of Manifolds: 18-1958-1 , 18-1962-1 . Use with Front Plate: 18-4009 . Included in 18-8512 mounting kit.
4	18-4009 FRONT PLATE	60252A2	Use with (Port & Starboard) Manifolds: 18-1958-1 , 18-1962-1 ; Mounting Kit: 18-8512
5	NSS MOUNTING BOLT	N/A	Included in 18-8512 mounting kit.
6	18-0183-1 MANIFOLD GASKET	27-73866	Use with Manifold: 18-1958-1 , 18-1962-1 . Included in 18-8509 mounting kit.
7	NSS MOUNTING BOLT	N/A	Included in 18-8509 mounting kit.
8	18-8514 MOUNTING KIT	N/A	Use with Elbows: 18-1971 & 18-1978 . Includes 18-2833 gasket & 18-4008 block off plate.
9	18-8554 MOUNTING KIT	N/A	Use with Manifold Spacer: 18-1906 with Riser 18-1971 or 18-1978 . Includes (1) 18-2849-1 & 18-0897 elbow gaskets.
10	18-4362 MOUNTING KIT	N/A	Use with Elbows: 18-1971 & 18-1978 . Includes 18-2833 elbow gasket.
11	18-8512 MOUNTING KIT	N/A	Use with Front/End Plates: 18-4009 . Includes 18-2832-1 gasket.
12	NSS END PLATE	54870	Fits Manifolds: 18-1958-1 , 18-1962-1 ; Mounting Kit: 18-8512 .
13	18-4008 BLOCK OFF PLATE	60207	Use with Manifolds 18-1958-1 , 18-1962-1 . Requires (2) 18-2833 elbow gaskets.
14	18-2833 ELBOW GASKET	27-99777-2	Use with Elbows: 18-1971 & 18-1978 . Included in 18-4362 mounting kit.
15	18-1978 MANIFOLD ELBOW	76771A3	Use with Manifolds: 18-1958-1 , 18-1962-1 ; Elbow Gasket 18-2833 ; Mounting Kit 18-4362 .
16	18-1971 MANIFOLD ELBOW	76351A2	Use with Manifolds: 18-1958-1 , 18-1962-1 ; Elbow Gasket 18-2833 ; Mounting Kit 18-4362 .
17	18-3233 MOUNTING STUD	16-49545	3/8-24, 3/8-16 X 1 3/4. Included in 18-4362 mounting kit.
18	NSS MOUNTING STUD	N/A	Included in 18-8554 mounting kit.
19	18-1906 MANIFOLD SPACER	61851	3" Spacer for Manifolds: 18-1950-1 , 18-1951-1 . Use with mounting kit 18-8554 with 18-1971 or 18-1978 Elbows.
20	18-8509 MOUNTING KIT	N/A	Use with Manifolds: 18-1958-1 , 18-1962-1 . Includes 18-0183-1 manifold gasket.
21	18-2849-1 ELBOW GASKET (OPEN)	27-818832	Fits Manifolds: 18-1958-1 , 18-1962-1 ; Manifold Spacers: 18-1985 . Included in 18-8554 mounting kit.
22	18-0897 ELBOW GASKET (RESTRICTOR)	27-41813	Fits Manifolds: 18-1958-1 , 18-1962-1 ; Manifold Spacers: 18-1985 . Included in 18-8554 mounting kit.



**Fits GM 4 Cylinder 181 cu. in.
Models 120, 140, 2.5L & 3.0L**

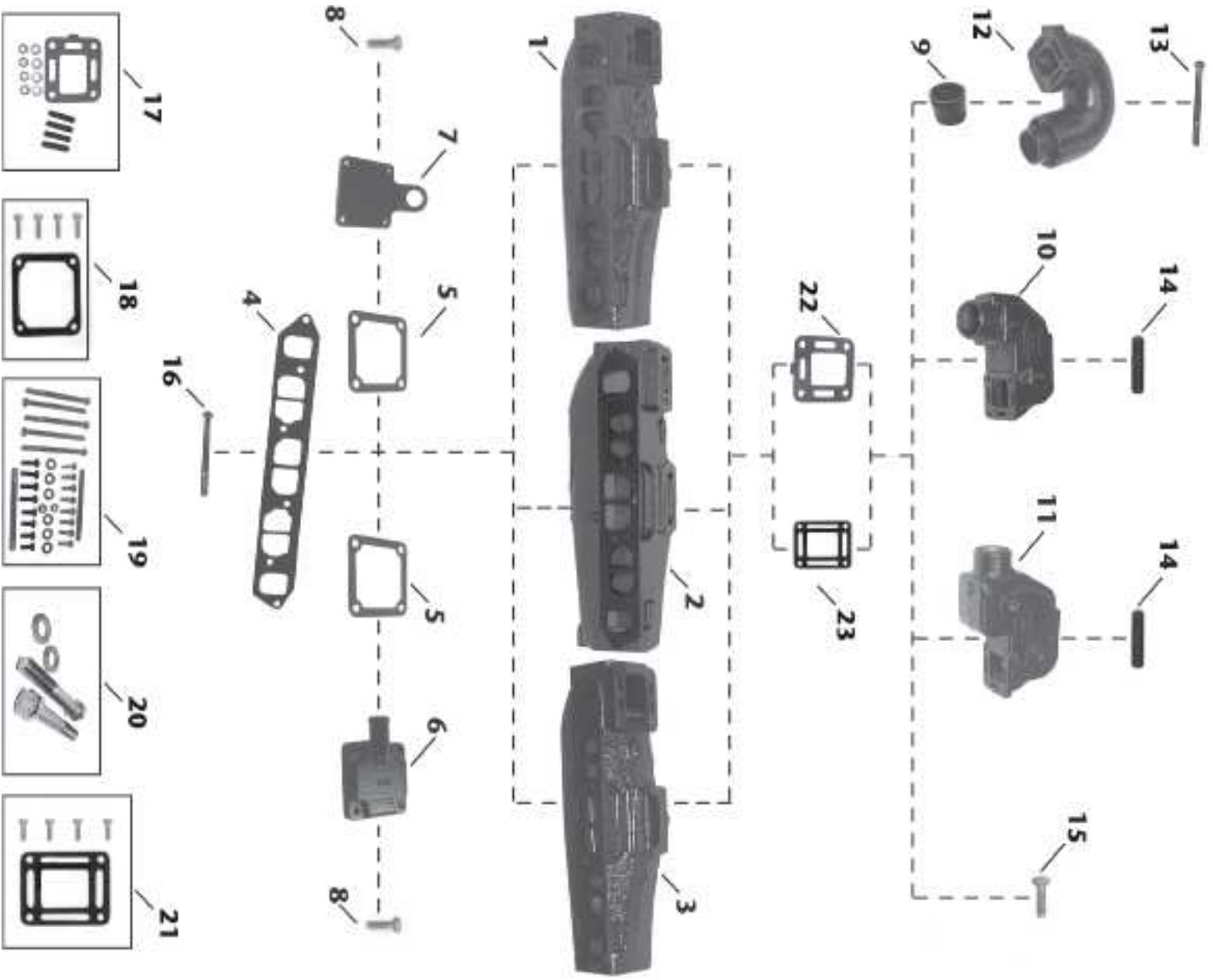

Item No.	Description	OE No.	Application	
1	18-1954-1	MANIFOLD	9582A5	Fits 2.5 & 3.0L 181 CID, Model 140 with Rochester carburetor w/ electrical choke (1983-89). Use with Manifold Gasket: 18-1204-1 .
2	18-1955-1	MANIFOLD	96705A1	Fits 3.0L 181 CID, Model 140 with Rochester carburetor w/ mechanical choke (1968-82). Use with Manifold Gasket: 18-1204-1 . Mounting Hardware: 18-8549 .
3	18-1956-3	MANIFOLD	99798A18	Fits 3.0L 181 CID, Model 140 & 3.0 with Mercarb carburetor w/ electrical choke (1983-95). Use with Manifold Gasket: 18-1204-1 .
4	18-1204-1	MANIFOLD GASKET	27-96429	Fits Manifolds: 18-1954-1 , 18-1955-1 , 18-1956-3
5	18-2832-1	FRONT/ END CAP GASKET	27-48043-1	Fits Port & Starboard Caps of Manifolds: 18-1954-1 , 18-1955-1 , 18-1956-3 .
6	18-4009	FRONT PLATE	60252A2	Fits Manifolds: 18-1954-1 , 18-1955-1 , 18-1956-3
7	18-5021	END PLATE	805629	Fits Manifolds: 18-1954-1 , 18-1955-1 , 18-1956-3
8	NSS	MOUNTING BOLT	N/A	Included in 18-8512 mounting kit.
9	18-2748	EXHAUST BOOT	32-44348T	4" Inside Diameter. Use with 18-1975-1 elbow.
10	18-1971	MANIFOLD ELBOW	76351A2	Use with Manifolds: 18-1954-1 , 18-1955-1 , 18-1956-3 ; Elbow Gasket 18-2833 ; Mounting Kit 18-4362
11	18-1978	MANIFOLD ELBOW	76771A3	Use with Manifolds: 18-1954-1 , 18-1955-1 , 18-1956-3 ; Elbow Gasket 18-2833 ; Mounting Kit 18-4362
12	18-1975-1	MANIFOLD RISER	12076A2	Use with Manifolds: 18-1954-1 , 18-1955-1 , 18-1956-3 ; Elbow Gasket 18-2819-1 ; Mounting Hardware 18-8551 ; Exhaust Boot 18-2748 .
13	NSS	MOUNTING BOLT	N/A	Included in 18-8551 mounting hardware.
14	18-3233	MOUNTING STUD	N/A	3/8-24, 3/8-16 X 1 3/4. Included in 18-4362 mounting kit.
15	NSS	MOUNTING BOLT	N/A	Included in 18-8508 mounting kit.
16	NSS	MOUNTING BOLT	N/A	Included in 18-8549 mounting kit.
17	18-4362	MOUNTING KIT	N/A	Use with Elbows: 18-1971 & 18-1978 . Includes 18-2833 elbow gasket
18	18-8512	MOUNTING KIT	N/A	Use with Front Plate: 18-4009 & End Plate (NSS). Includes 18-2832-1 front/end cap gasket.
19	18-8549	HARDWARE KIT	N/A	Includes only hardware for 18-1955-1 manifold.
20	18-8551	HARDWARE KIT	N/A	Includes only hardware for 18-1975-1 elbow.
21	18-8508	MOUNTING KIT	N/A	Use with Elbow 18-1973 . Includes 18-2819-1 elbow gasket.
22	18-2833	ELBOW GASKET	27-99777-2	Use with Elbows: 18-1971 & 18-1978 . Included in 18-4362 mounting kit
23	18-2819-1	ELBOW GASKET	27-39915	Use with Elbow: 18-1973 . Included in 18-8508 mounting kit.



**Fits GM Small Block V8 305 & 350 cu. in.
Models 200, 228, 230, 260 & 898**

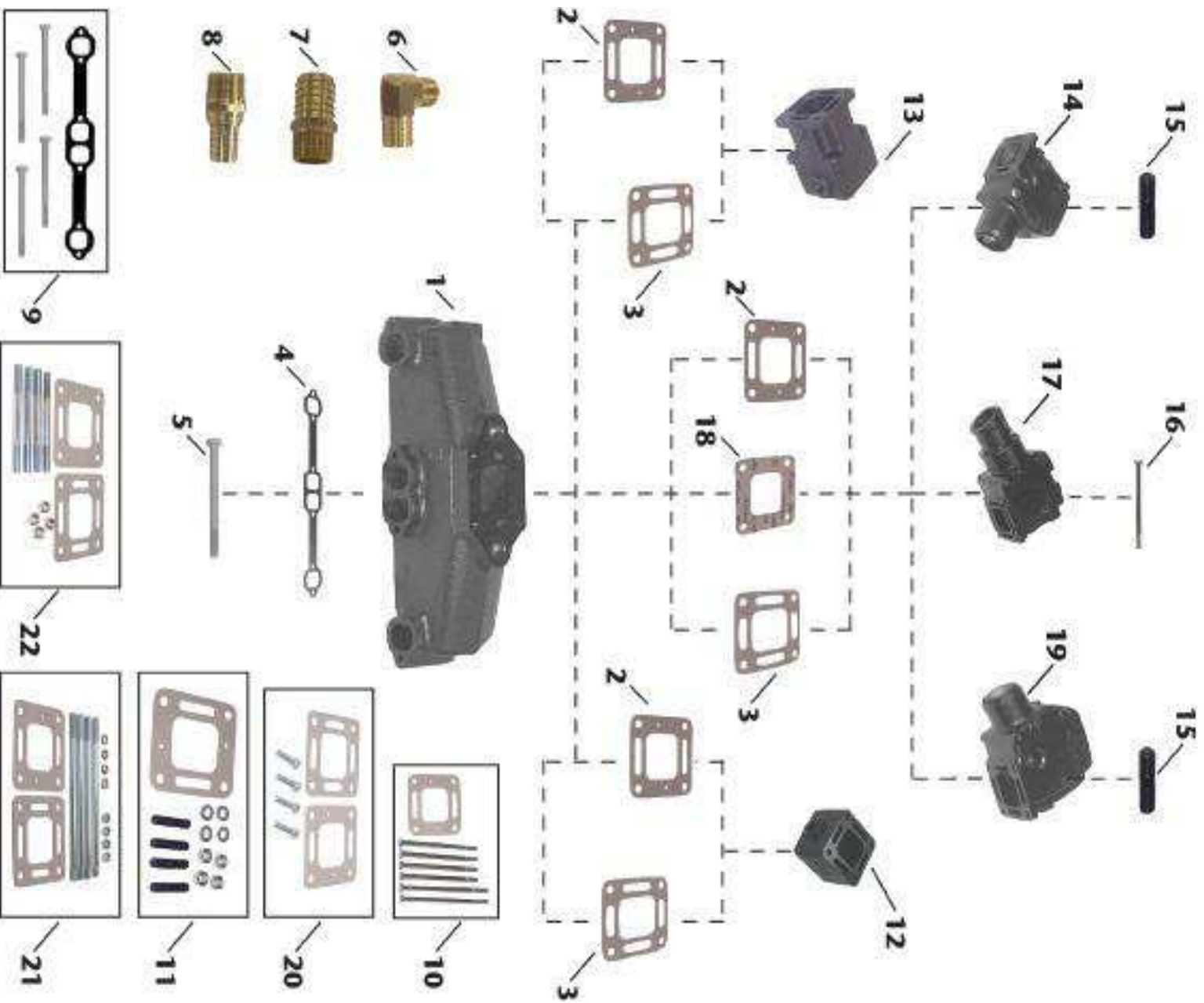

Item No.	Description	OE No.	Application	
1	18-1953-2	MANIFOLD	87114A19	GM Small Block (V8) 305-350 cu.in. Models 200, 228, 230, 260, & 898
2	18-0897	ELBOW GASKET (RESTRICTOR)	27-41813	Fits Manifold: 18-1953-2 ; Manifold Spacers: 18-1985 , & 18-1908 ; Elbows: 18-1970-2 , 18-1976-2 , 18-1974-1
3	18-2849-1	ELBOW GASKET (OPEN)	27-818832	Fits Manifold: 18-1953-2 ; Manifold Spacers: 18-1985 , & 18-1908 ; Elbows: 18-1970-2 , 18-1976-2 , 18-1974-1
4	18-2949	MANIFOLD GASKET	96306	Use with Manifold: 18-1953-2 . Included in 18-8520 mounting kit.
5	NSS	MOUNTING BOLT	N/A	Included in 18-8520 mounting kit
6	18-8216	HOSE FITTING	22-36305	3/4" - 14NPT X 1" Hose (Corrosion Resistant Brass Fitting)
7	18-4461	HOSE FITTING	N/A	3/4" - 14NPT X 1" Hose (Corrosion Resistant Brass Fitting)
8	18-8215	HOSE FITTING	N/A	3/4" - 14NPT X 3/4" Hose (Corrosion Resistant Brass Fitting)
9	18-8520	MOUNTING KIT	N/A	Use with Manifold: 18-1953-2 . Includes 18-2949 manifold gasket.
10	18-8505	MOUNTING KIT	N/A	Use with Riser: 18-1976-2 . Includes 18-0897 elbow gasket.
11	18-8529	MOUNTING KIT	N/A	Use with Risers: 18-1970-2 , 18-1974-1 . Includes 18-0897 elbow gaskets
12	18-1908	MANIFOLD SPACER	933220A12	3" Spacer for Manifold: 18-1953-2 . Use with mounting kit 18-8554 with 18-1970-2 , or mounting kit 18-8555 with 18-1976-2 .
13	18-1985	MANIFOLD SPACER	93322	6" Spacer for Manifold: 18-1953-2 . Use with mounting kit 18-8556 . (Note to mount elbows to spacer a separate mounting kit is required)
14	18-1974-1	MANIFOLD ELBOW (3" hose • 0° down angle)	98502A2	Fits Manifold: 18-1953-2 . Use Elbow gasket: 18-2849-1 , 18-0897 , or 18-0672 ; Use mounting kit: 18-8529 . (Do not use with spacer)
15	NSS	MOUNTING STUD	N/A	Included in 18-8529 mounting kit.
16	NSS	MOUNTING BOLT	N/A	Included in 18-8505 mounting kit.
17	18-1976-2	MANIFOLD ELBOW (4" hose • 7° down angle)	44354A3, 807914A1	Fits Manifold: 18-1953-2 . Use Elbow gasket: 18-2849-1 , 18-0897 , or 18-0672 ; Use mounting kit: 18-8505 , or if spacer is included use 18-8555 .
18	18-0672	ELBOW GASKET (CLOSED)	27-860231	Fits Manifold: 18-1953-2 ; Manifold Spacers: 18-1985 , & 18-1908 ; Elbows: 18-1970-2 , 18-1976-2 , 18-1974-1
19	18-1970-2	MANIFOLD ELBOW (3" hose • 15° down angle)	98504A3	Fits Manifold: 18-1953-2 . Use Elbow gasket: 18-2849-1 , 18-0897 , or 18-0672 ; Use mounting kit: 18-8529 , or if spacer is included use 18-8554 .
20	18-8556	MOUNTING KIT	N/A	Use with Manifold Spacer: 18-1985 . Includes 18-0897 & 18-2849-1 . (Note: To mount elbows to spacer a separate mounting kit is required)
21	18-8555	MOUNTING KIT	N/A	Use with Riser Kit 18-1908K : Spacer 18-1908 : Riser 18-1976-2 : Manifold: 18-1953-1
22	18-8554	MOUNTING KIT	N/A	Use with Riser Kit 18-1908K : Spacer 18-1908 : Riser 18-1970-2 : Manifold: 18-1952-1



SIERRA MANIFOLDS ARE PAINTED, PACKAGED & LEAK TESTED

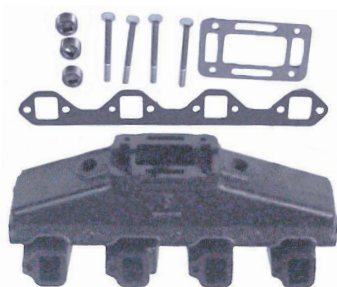

**18-1998-1
MANIFOLD**

Port & Starboard

Replaces: Barr FM-1-83
Universal Center Riser Manifold

Fits: Ford 302 and 351 CID engines

Comes with 18-4363 Mounting Package

Use with: Exhaust Manifold Gasket Set: 18-0603

*For Exploded View - See Pages 640-641



**18-1997-1
MANIFOLD**

Port & Starboard

Replaces: Barr CHV-1-83 Universal Center Riser Manifold

Fits: GM 283, 305, 307 and 350 CID engines

Use with: Exhaust Manifold Gasket Set: 18-0604

*For Exploded View - See Pages 638-639



**18-1898
MANIFOLD**

Port & Starboard

Replaces: Barr CHVA-1-84, Marine Power 0991-110

Fits: 454 cu. in. GM big block V8 engines

Use with:

Exhaust Manifold Gasket: 18-0418

Riser: 18-1939, 18-1999

*For Exploded View - See Pages 636-637



**18-1951-1*
MANIFOLD**

Supplied with Mounting Package

Replaces: 77235A2, 77235A8

Barr MC-1-77235

STARBOARD SIDE

Fits: Most Mercruiser (GM) small blocks with end riser

Use with:

Exhaust Manifold Gasket: 18-2949

Mounting Kit: 18-8548



**18-1950-1*
MANIFOLD**

Supplied with Mounting Package

Replaces: 77234A2, 77234A7

Barr MC-1-77234

PORT SIDE

Fits: Most Mercruiser (GM) small blocks with end riser

Use with:

Exhaust Manifold Gasket: 18-2949

Mounting Kit: 18-8548



**18-1952-1*
MANIFOLD**

Port & Starboard

Replaces: Mercruiser 99746A8, A17

Marine Power 611447, Barr MC-1-99746

Fits: Most 4.3L (262 CID) V-6 application

Supplied with Mounting Package

Use with:

Mounting Kit: 18-8533



**18-1953-2
MANIFOLD**

Port & Starboard

Supplied with Mounting Package

Replaces: Mercruiser 87114A19, 86024A10, 860246A15, 860246A3,

860246A7, 860246A9, 860336A2, 860337A2, 87114A19, 87114A30

Marine Power 0994-100, Barr MC-1-87114

Will fit either side - Fits most Mercruiser(GM) small blocks with center riser.

Supplied with gaskets

Use with:

Mounting Kit: 18-8520



**18-1954-1*
MANIFOLD**

Supplied with Mounting Package

Replaces: Mercruiser 95862A5

Marine Power 0993-000, Barr MC 1 95862

Fits: Most late Model 2.5L 153 CID & 3.0L 181 CID with Rochester Carb

5 BOLT PATTERN (1983-89)

Use with:

Exhaust Manifold Gasket: 18-1204-1

End Plate: 18-4009

* SEE APPLICATION CHART ON PAGES 783-789 FOR SPECIFIC MODELS

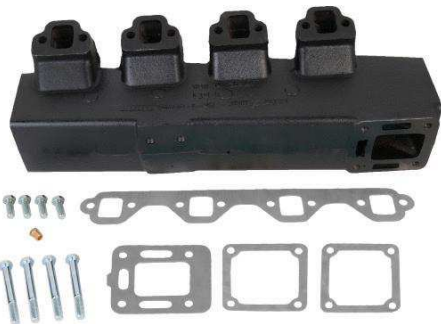

18-1958-1*
MANIFOLD

Replaces: 65604A4, A12, 54100A1, 54100A5
 Barr MC-1-65604 **PORT SIDE ONLY**
Fits: Most Mercruiser (Ford) V-8 small blocks
Supplied with Mounting Package
 Use with:
 Mounting Kit: 18-8509



18-1955-1*
MANIFOLD

New Style
Supplied with Mounting Package
Replaces: 96705A1, 52390A1
 Barr MC 1 96705
Fits: Most early Model 3.0L 181 CID with Rochester Carb. 5 bolt pattern and 2.5L, 153CID (1968-82)
 Use with:
 Exhaust Manifold Gasket: 18-1203
 End Plate: [18-4009](#)



18-1956-3
MANIFOLD

Supplied with Mounting Package
Replaces: Mercruiser 860235A04, 99798A3, 99798A9, 99798A16, 99798A18, 806867A8
 Marine Power 600333
 Barr MC 1 99798
Fits: 2.5 & 3.0L (1983-89)



18-1957-2*
MANIFOLD

Port & Starboard
Replaces: Mercruiser 89011A8, 807078A6, 807078T10, 80707809, 807078A4, 807078A2
 Marine Power 0991-1000, Barr MC-1-89011
WILL FIT EITHER SIDE
Fits: Most Mercruiser (GM) V-8 big blocks with center riser
 Use with:
 Exhaust Manifold Gasket: [18-0418](#)
 Mounting Kit: [18-8532](#)



18-1960-1*
MANIFOLD

Replaces: 58759A10, A14, 58759A13, 58759A1, 52969A1, 52073A1
 Barr MC 1 58759
Fits: Most Mercruiser (GM) Inline 6 Cyl. Engines
Supplied with Mounting Package
 Use with:
 Mounting Kit: [18-8531](#)

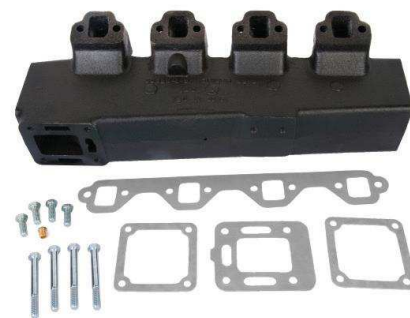

18-1962-1*
MANIFOLD

Starboard
Replaces: 65603A4, 65603A12, 54099A5, 54099A1
 Barr MC-1-65603
Fits: Most Mercruiser Engines (Ford) V-8 Small blocks
Supplied with Mounting Package
 Use with:
 Mounting Kit: 18-8509

18-1987-1
MANIFOLD
CONVERSION KIT

Not for use on engines with high mounted power steering pumps.

KIT INCLUDES:

- 2 Center rise manifolds
 - 2 Exhaust elbows
 - 1 Thermostat housing
 - 1 Thermostat cover
 - 1 Thermostat
- All hoses, hardware, gaskets plus complete instructions to do the job right!



This Manifold Kit is designed to convert all Mercruiser Stern Drive Engines with GM 305 & 350 CID Blocks that have Log Style Exhaust Manifolds and Raw Water Cooling to the Newer More Efficient Center Rise Manifolds



**18-1966-1
MANIFOLD**

Replaces: 806867A2, 806867A3, 806867A8, 806867A9, 806867A12, 816329A3, 860235A03, 99798A18
Fits: 3.0L/LX (1990 & Newer); Marine Power Engine Model E181S



**18-1843
EXHAUST MANIFOLD (DRY JOINT)**

Replaces: 865735A02, 865049T01, 864308T01
Fits: 305, 350, 377, 5.0L, 5.7L, 6.2L(2002 and Newer)
Use with:
Manifold Gasket: **18-2949**
Elbow Gaskets: **18-0720, 18-0721** or **18-0722**
Elbow: **18-1845**



**18-1842
V6 DRY JOINT EXHAUST MANIFOLD**

Replaces: 864612T01
Fits: 4.3L Alpha/Bravo (2002 and Newer without Engine Catalyst)
Use with:
Dry Joint Elbow Gaskets: **18-0720, 18-0721** or **18-0722**



**18-1999
ELBOW**

Replaces: Barr 20-0082
Fits: 3" I.D. exhaust hose.
Comes with 18-4364 open Mounting Package
Use with:
Manifold: **18-1997-1** or **18-1998-1** or **18-1898**
Riser Gasket: **18-2854-1** open or **18-0476-1** blocked
Mounting Kit: **18-4364** open or **18-8535** blocked



**18-1970-2*
ELBOW**

Replaces: Mercruiser 98504A3, 98503A2, 95755A2
Marine Power 0992-115, Barr MC-20-98504
Fits: V-6 & V-8 applications, 15" (3" O.D. Riser) Comes with **18-0897** & brass plugs
Use with:
Manifold: **18-1952-1, 18-1953-2, 18-1957-2**
Elbow Gasket: **18-0897** restrictor, **18-2849-1** open, **18-0672** blocked
Mounting Kit: **18-8529**



**18-1971*
ELBOW**

Replaces: Mercruiser 76351A2, 76351A1, 76351A04, 60426A1, 49964A1, 49964A2
Marine Power 0993-001
Fits: Most early model Mercruiser 140 HP (4 cyl) applications
Replaces: Barr MC20-60426P
Use with:
Manifold: **18-1960-1, 18-1958-1, 18-1950-1**
Elbow Gasket: **18-2833**
Mounting Kit: **18-4362**



**18-1992-1
EXHAUST ADAPTER**

Replaces: Barr 200087P
For: 3" I.D. Exhaust Hose
(As used in 18-1987 Exhaust Manifold Conversion Kit) 80°



**18-1972*
ELBOW**

Replaces: 76325A2, 12076A2
Barr MC-20-76325
Fits: Most late Model 120, 140 HP Mercruiser applications
Use with:
Manifold: **18-1955-1, 18-1954-1, 18-1956-3, 18-1901**
Elbow Gasket: **18-2833**
Mounting Kit: **18-8552**



**18-1973*
ELBOW**

Replaces: 39920, 39920A1, 55538A2
Barr MC-20-55538
Fits: Most early Model 120 HP Mercruiser applications



**18-1991
ELBOW ADAPTER**

Replaces: Barr 200089P
For: Use with 3" I.D. Exhaust Hose
Use with:
Manifold Riser: **18-1999** 30°



**18-1978
ELBOW**

Replaces: 76771A3, A2, 60427A2, 53779A2, 53779A1
Barr MC-20-76771
V-8 Inboard Applications Only
Use with:
Manifold: **18-1950-1, 18-1951-1, 18-1958-1, 18-1962-1**
Elbow Gasket: **18-2833**
Mounting Kit: **18-4362**

* SEE APPLICATION CHART ON PAGES 783-789 FOR SPECIFIC MODELS



18-1905
ELBOW
Replaces: 90880
Mer cruiser 4 Cylinder 224cu. in. 3.7L (Models: 165, 170, 180, 190).
Use with:
Manifold: Mer cruiser 99908
Exhaust Elbow Mounting Gasket: **18-0113-1**
Mounting Kit: **18-8500**



18-1937
ELBOW
Replaces: 98562A6
Mer cruiser 4 Cylinder 224cu. in. 3.7L (Models: 165, 170, 180, 190).
Use with:
Exhaust Elbow Mounting Gasket: **18-0881-1**
Mounting Kit: **18-8530**



18-1974-1*
ELBOW
Replaces: 98502A2, Barr MC-20-98502
Fits: V-6 & V-8 applications 0° (3" O.D. Riser)
Comes with **18-0897** gasket & brass plugs



18-1976-2*
ELBOW
Replaces: Mer cruiser 44354A3, 44354A9, 44354A10, 44354A13, 807914A1, 807988A2, 807988A03
Marine Power 0992-400, Barr MC-20-44354
Fits: Most Mer cruiser V-6 & V-8 applications 7° (4" O.D. Riser) Comes with **18-0897**, **18-4263** & **18-4258**
Use with:
Manifold: **18-1952-1**, **18-1953-2**, **18-1957-2**
Riser Gasket: **18-0897** restrictor, **18-2849-1** open, **18-0672** blocked
Mounting Kit: **18-8505**



18-1845
EXHAUST ELBOW (DRY JOINT)
Replaces: 864591T02
Fits: 2004 & Up V6 & V8(305, 350, 377) SN 0W310000 & Up, 2002 & Up V8(350 & 377) SN 0M317000 & Up
Use with:
Manifolds: **18-1843**, **18-1842**
Dry Joint Elbow Gaskets: **18-0720**, **18-0721** or **18-0722**



18-1907
RISER
Replaces: Barr 20-0102, Indmar 53-2009 and 53-2018
Barr, Indmar Ford Small Block V8 302-351cu. in. • Use with 3" hose.
Use with:
Manifold: **18-1997-1**, **18-1998-1**
Riser Gasket: **18-2854-1** open or **18-0476-1** blocked
Mounting Kit: **18-4364** open or **18-8535** blocked



18-1939
RISER
Replaces: Barr 20-0100, Marine Power 0992-593
Barr, Indmar and Marine Power Ford Small Block V8 302-351cu. in. GM Small Block V8 305-350cu. in., GM Big Block V8 454cu in. • Use with 3 1/2" hose.
Use with:
Manifold: **18-1997-1**, **18-1998-1**, **18-1898**
Riser Gasket: **18-2854-1** open or **18-0476-1** blocked
Mounting Kit: **18-4364** open or **18-8535** blocked



18-1975-1*
RISER
Replaces: Mer cruiser 12076A1, 12076A2, 95864A2
Marine Power 6000-33A
Fits: late Model Mer cruiser 4 cyl. Engines
Use with:
Manifold: **18-1955-1**, **18-1954-1**, **18-1956-3**, **18-1901**
Riser Gasket: **18-2833**
Mounting Kit: **18-8551**
Bellow: **18-2748**



18-1908K
MANIFOLD RISER SPACER KIT
Replaces: 807476A6, 93320A2, 93320A3, 93320A5, 93320A6, 93320A13
Alpha/Bravo/Gen+/GenIV GM Small Block V-8 305, 350, 4.3L, 454, 5.0, 5.7L, 502, 7.4L, 8.2L, (3" Riser Kit)
Complete with Mounting Hardware. Center Rise 3" PACKAGED AS SET
Use with:
Manifold: **18-1952-1**, **18-1953-2**, **18-1957-2** 3"



18-1906
MANIFOLD SPACER
Replaces: 61851A1
3" Spacer for 18-1950, 18-1951, 18-1958-1 & 18-1962-1 manifolds



18-1908
MANIFOLD RISER SPACER - 3"
Replaces: 93320
Mer cruiser GM V6 229 and 262cu.in. (Models: 185 and 205), GM Small Block V8 305-350cu.in. (Models: 200, 228, 230, 260 and 898), GM Big Block V8 454cu.in. (Models: 330, 340 and 7.4L)
Used with:
Manifolds: **18-1952-1**, **18-1953-2**, **18-1957-2**



18-1985
MANIFOLD SPACER - 6"
Replaces: Mer cruiser 93322
Marine Power 612011
Barr MC-20-93322A3
For: 229 and 262 V6, 305-350 Small Block V8, 454 Big Block V8
Used with:
Manifold: **18-1952-1**, **18-1957-2**, **18-1953-2**



18-1949
MANIFOLD SPACER
Barr CM 20-0097
3" Spacer for Barr, Indmar and Marine Power Ford Small Block V8 302-351cu.in., GM Small Block V8 305-350cu.in., GM Big Block V8 454cu.in.
Used with:
Manifold: **18-1998-1**, **18-1997-1** and **18-1898**



18-1990
MANIFOLD BLOCK OFF PLATE
 Replaces: 48045, 54870, 73813, 73813A1, 73813F1
 Barr 1-73813



18-5021
END PLATE
 Replaces: 805629
 Use with:
 Manifold: **18-1954-1**,
18-1955-1, 18-1956-3



18-4008
BLOCK-OFF PLATE
 Replaces: 60207
 Barr MC-20-60207
 Use with:
 Riser: **18-1971, 18-1978**



18-1995
MANIFOLD END PLATE
 Replaces: 47638, 47638A1
 GM 4 cyl. 153 cu. in.
 For: Model 110/120 where carb. linkage mounts to the rear of the engine

PIPE PLUGS



Part #	Replaces	Thread Size	Description
18-4257	—	1/4"	Blacksteel Plug
18-4263	22-32802, 22-328022, 22-328021, 22-841908, 22-30139, F700633, F15810151,	1/8" - 27 NPT	Pipe Plug
18-4264	22-32803, 22-87543, F15880010	3/8" - 18 NPT	Pipe Plug
18-4265	22-428611, 22-42861, 22-861187	3/4" - 14 NPT	Pipe Plug (Brass hexdrive)
18-8111 ①	22-36392	1/4" - 18 NPT	Pipe Plug
18-4258	22-33198A1, 22-41622	3/4" - 14 NPT	Pipe Plug (Stainless steel w/ square drive)

56507 Pipe Sealant with Teflon® is recommended for use on plug threads.

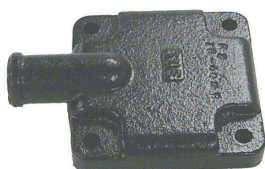

18-4009
MANIFOLD END PLATE
 Replaces: 52999, 60252, 60252A2
 Barr 160252
 Use with:
 Manifold: **18-1960-1, 18-1958-1**,
18-1950-1, 18-1951-1
 End Plate Gasket: **18-2832-1**
 Mounting Kit: **18-8512**



RISER BOLTS

Part #	Replaces	Thread Size	Description
18-8410	10-43749	3/8"-16 x 5 3/4"	Use w/o remote oil filter
18-8411	10-44387	1/8" - 16 x 6 3/4"	Use with remote oil filter



18-4363
EXHAUST ELBOW MOUNTING KIT
 Replaces: Barr FM-1-83-P
 Use with:
 Manifold: **18-1998-1**



18-4362
EXHAUST ELBOW MOUNTING KIT
 Replaces: Barr MC20-60426P
 Use with:
 Elbow: **18-1971**



18-8500
EXHAUST ELBOW MOUNTING KIT
 Mercruiser 4 Cylinder 224cu.in. 3.7L (Models: 165, 170, 180, 190)
 Used with:
 Elbow/Reservoir: **18-1905**



18-8505
EXHAUST ELBOW MOUNTING KIT
 Mercruiser GM V6 229 and 262cu.in. (Models 185 and 205), GM Small Block V8 305-350cu.in. (Models: 200, 228, 230, 260, 898), GM Big Block V8 454cu.in. (Models: 330, 340 and 7.4L)
 Used with:
 Riser: **18-1976-2**

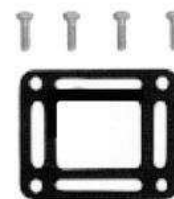

18-8508
EXHAUST MANIFOLD MOUNTING KIT
 Mercruiser GM 4 Cylinder 153cu.in. (Early models 110/120), GM Inline Cylinder 250cu.in. (Model: 160)
 Used with:
 Riser: **18-1973**

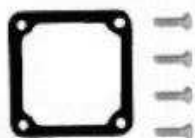

18-8512
EXHAUST ELBOW MOUNTING KIT
 Mercruiser GM 4 Cylinder 181cu.in. (Models: 120,140, 2.5L,3.0L), GM Inline 6 Cylinder 250-292cu.in. (Models: 165 and 200), Ford Small Block V8 302-351cu.in. (Models: 215,225,233, 255,888), GM Small Block V8 305, 350cu.in. (Models: 198,228,898)
 Used with:
 Front Plate: **18-4009**



18-8514
EXHAUST ELBOW MOUNTING KIT
 Mercruiser Ford Small Block V8 302-351cu.in. (Models: 215, 225, 233, 255, 888), GM Small Block V8 305-351cu.in. (Models: 198,228,898)
 Used with:
 Riser: **18-1971 & 18-1978**
 (Not for Fresh Water/Closed Cooling Systems)

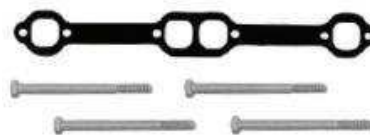

18-8520
EXHAUST MANIFOLD MOUNTING KIT
 Mercruiser GM Small Block V8 305-350cu.in. (Models: 198, 200, 228, 230, 260, 898)
 Used with:
 Manifold: **18-1950-1, 18-1951-1, 18-1953-2**

① This product is priced per piece. To order priced per package, please add -9 to the part number



18-4364 (Open)
EXHAUST ELBOW MOUNTING KIT
 Replaces: Barr 20-0082-P
 Use with:
 Riser: 18-1999, 18-1907, 18-1939



18-8529
EXHAUST ELBOW MOUNTING KIT
 Mercruiser GM V6 229 and 262cu.in. (Models 185 and 205), GM Small Block V8 305-350cu.in. (Models: 200, 228, 230, 260, 898), GM Big Block V8 454cu.in. (Models: 330, 340 and 7.4L)
 Used with:
 Riser: 18-1970-2



18-8530
EXHAUST ELBOW MOUNTING KIT
 Mercruiser 4 Cylinder 224cu.in. 3.7L (Models: 165, 170, 180, 190)
 Used with:
 Elbow/Reservoir: 18-1937



18-8531
EXHAUST MANIFOLD MOUNTING KIT
 Mercruiser GM Inline 6 Cylinder 250cu.in. (Models: 165 and 200)
 Used with :
 Manifold: 18-1960-1



18-8532
EXHAUST MANIFOLD MOUNTING KIT
 Mercruiser GM Big Block V8 454cu.in. (Models: 330, 340 and 7.4L)
 Used with:
 Manifold: 18-1957-2



18-8533
EXHAUST MANIFOLD MOUNTING KIT
 Mercruiser GM V6 229 and 262cu.in. (Models 185 and 205)
 Used with:
 Manifold: 18-1952-1



18-8535 (Blocked)
EXHAUST ELBOW MOUNTING KIT
 Barr, Indmar and Marine Power
 Ford Small Block V8 302-351cu.in., GM Small Block V8 305-350cu.in., GM Big Block V8 454cu. in.
 Used with:
 Risers: 18-1939, 18-1999, and 18-1907



18-8536
EXHAUST ELBOW MOUNTING KIT
 Barr, Indmar and Marine Power GM Small Block V8 305-350cu.in.
 Used with:
 Manifold: 18-1997-1



18-8538
EXHAUST MANIFOLD MOUNTING KIT
 Barr and Indmar Ford Small Block V8 302-351cu.in.
 Used with:
 Manifold: 18-1998-1



18-8554
EXHAUST ELBOW MOUNTING KIT
 For: 229 and 262 ci V6, 305 and 350 SB V8, 454 Big Block V8.
 Used with:
 Riser Kit: 18-1908K and 18-1908 Spacer
 Riser: 18-1970-2
 Manifold: 18-1952-1, 18-1953-2 & 18-1957-2



9 1/2" studs —

18-8555
EXHAUST ELBOW MOUNTING KIT
 For: 229 and 262 ci V6, 305 and 350 SB V8, 454 Big Block V8.
 Used with:
 Riser Kit: 18-1908K and 18-1908 Spacer
 Riser: 18-1976-2
 Manifolds: 18-1952-1, 18-1953-2 & 18-1957-2



18-8556
EXHAUST ELBOW MOUNTING KIT
 For: 229 and 262 ci V6, 305 and 350 SB V8, 454 Big Block V8. Used to mount Spacer 18-1985 to 18-1953-2, 18-1957-2 and 18-1952-1 Manifolds

HARDWARE KITS











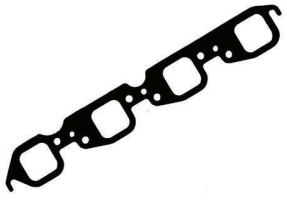
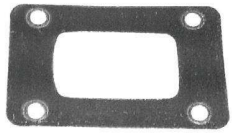







Part No.	Fits
18-8548	18-1950-1 & 18-1951-1 Manifold
18-8549	18-1950-1 Manifold
18-8551	18-1975-1 Exhaust Elbow





18-0183-1
EXHAUST MANIFOLD GASKET
 Replaces: Mercruiser 27-73866, 27-54566
 Volvo 3853742, 3852455, OMC 908717
 Used with:
 Manifold: 18-1962-1, 18-1938, 18-1998-1, 18-1996, 18-1979



18-0353
CARB MOUNTING GASKET
 Replaces: 27-58764
 Used with:
 Manifold: 18-1960-1

 <p>18-0418 EXHAUST MANIFOLD GASKET Replaces: 27-46820 Use with: Manifolds: 18-1957-2, 18-1982, 18-1929, 18-1933, 18-1898</p>	 <p>18-0476-1 RISER BLOCK OFF GASKET Barr, Indmar & Marine Power Ford Small Block V8 302-351cu.in. Used with: Risers: 18-1939, 18-1999, 18-1907</p>	<p>PKG. OF 2</p>  <p>18-0672 18-0672-9^① EXHAUST ELBOW GASKET Replaces: 27-860231, 8637251, 27-41811, 27-863725 Used with: Riser: 18-1970-2, 18-1976-2</p>	 <p>18-0881-1 EXHAUST ELBOW GASKET Replaces: 27-18272, 27-97863 Included in 18-8530 mounting kit Used with: Elbow: 18-1937</p>
 <p>18-0885-1 18-0885-9^① EXHAUST ELBOW GASKET Replaces: 27-48042</p>	 <p>18-0897 (Restrictor) EXHAUST ELBOW GASKET Replaces: 27-41813, 27-860233, 27-863724 Used with: Riser: 18-1976-2, 18-1970-2</p>	 <p>18-1204-1 18-1204-1-9^① EXHAUST MANIFOLD GASKET Replaces: 27-96429</p>	<p>PKG. OF 2</p>  <p>18-2819-1 18-2819-9^① EXHAUST ELBOW GASKET Replaces: 27-39915</p>
 <p>18-2830-1 EXHAUST MANIFOLD GASKET 6 cyl. Replaces: 27-46401</p>	<p>PKG. OF 2</p>  <p>18-1210-1 END CAP GASKET Replaces: 27-39923</p>	<p>PKG. OF 2</p>  <p>18-2832-1 18-2832-1-9^① MANIFOLD END CAP GASKET Replaces: 27-480431 Use with: Manifolds: 18-1951-1, 18-1950-1, 18-1954-1, 18-1958-1, 18-1955-1, 18-1956-3, 18-1960-1, 18-1962-1 End Plate: 18-4009</p>	 <p>18-2833 18-2833-9^① EXHAUST ELBOW GASKET Replaces: 27-997772</p>
<p>PKG. OF 2</p>  <p>18-2849-1 (Open) 18-2849-9-1^① EXHAUST ELBOW GASKET Replaces: 27-87105-1, 27-818832, 27-863726 Use with: Elbow: 18-1976-2, 18-1970-2</p>	<p>PKG. OF 2</p>  <p>18-2854-1 (Open) 18-2854-9^① EXHAUST ELBOW GASKET Replaces: Barr 01-0107 Use with: Riser: 18-1999, 18-1939, 18-1907</p>	 <p>18-2896-1 EXHAUST MANIFOLD GASKET Replaces: 27-52546, 27-32816 GM 4 cyl. 153 cu. in. For model 110/120 where carb. linkage mounts to the rear of the engine</p>	 <p>18-2909 18-2909-9^① EXHAUST MANIFOLD GASKET For: GM V-6 Used with: Manifold: 18-1952-1</p>
 <p>18-2912-1 EXHAUST MANIFOLD GASKET Replaces: 27-53354</p>	 <p>18-2949 18-2949-9^② EXHAUST MANIFOLD GASKET Replaces: Mercruiser 27-33395 Barr CHV-47-000 GM 5.0L & 5.7L Use with: Manifold: 18-1997-1, 18-1950-1, 18-1951-1</p>	 <p>18-0603 EXHAUST MANIFOLD GASKET SET For: Ford 302/351 CID Engines For use with 18-1998-1</p>	 <p>18-0604 EXHAUST MANIFOLD GASKET SET For: GM 305/350 CID Engines For use with 18-1997-1</p>

① Priced per Package

 <p>18-0720 DRY JOINT GASKET (CLOSED) Replaces: 27-864549A02, 27-864549A1 Fits: 4.3L, 5.0L, 5.7L, 6.2L utilizing the Dry Joint Manifold and Riser Used with: 18-1843, 18-1842 Manifolds & 18-1845 Riser</p>	 <p>18-0721 DRY JOINT GASKET (OPEN) Replaces: 27-864547A02, 27-864547A1 Fits: 4.3L, 5.0L, 5.7L, 6.2L utilizing the Dry Joint Manifold and Riser Used with: 18-1843, 18-1842 Manifolds & 18-1845 Riser</p>	 <p>18-0722 DRY JOINT GASKET (RESTRICTED) Replaces: 27-864850A02, 27-864547A1 Fits: 4.3L, 5.0L, 5.7L, 6.2L utilizing the Dry Joint Manifold and Riser Used with: 18-1843, 18-1842 Manifolds & 18-1845 Riser</p>
 <p>18-4218 DRAIN TAP Replaces: 22-87238, 22-16951A1, 22-64426, 22-16951Q1 1/4" NPT 18-3223-9Ⓜ Bulk pack of 12</p>	 <p>18-4224 DRAIN ELBOW ASSEMBLY Replaces: 22-806926A1, 22-862210A01 3/4" NPT</p>	 <p>18-4226 DRAIN PLUG Replaces: 22-806608A1, 22-806608A02</p>
 <p>18-4227 DRAIN ELBOW Replaces: 22-806926, 22-862210</p>	 <p>18-4461 HOSE BARB Replaces: 22-807155 3/4" - 14 NPT x 1" Hose Corrosion-Resistant Brass Fitting</p>	 <p>18-8216 HOSE BARB Replaces: 22-36305, 22-36305T 3/4"- 14 NPT x 1" hose barb Fits: Mercruiser- V6 (229 and 262ci), Small Block V8 (305-350ci), Big Block V8 (454ci)</p>

Ⓜ Items ending in "D" are Display Packaged - Regular number is Non-Display
Ⓜ Priced per Package

MANIFOLD/MANIFOLD GASKET APPLICATION

Liter	Model	Note	CID	# Cyl.	Stroke	Year Range	Serial # Range	Exh. Manifold Port	Exh. Manifold Starboard	Exh. Elbow	End Cap Front	End Cap Rear	Manifold Gasket	Exh. Elbow Gasket
2.5L	120		153	4	4	1966-1982	2046625 - 6229717						27-52546	18-2819-1
2.5L	120		153	4	4		2324347 - 3377340					18-1995	18-2896-1	18-2819-1
2.5L	120		153	4	4		3377341 - 5192408					18-1995	18-2896-1	18-2819-1
2.5L	120		153	4	4		5192049 - 6229717					18-1995	18-2896-1	18-2819-1
2.5	120		153	4	4	1983-1986	6229718 - B5311853			18-4009			18-1204-1	18-2833
2.5L	2.5L		153	4	4	1987-1989	B531854 - C853255	18-1956-3		18-4009	18-4009		18-1204-1	18-2833
3.0L	140		181	4	4	1968-1982	2508261 - 6229717	18-1955-1		18-1971	18-4009	18-1990	18-2912-1	18-2833
3.0L	140		181	4	4		3332138 - 5157668	18-1955-1				18-4009	18-1203	18-2833
3.0L	140		181	4	4		5157669 - 6229717	18-1955-1				18-4009	18-1203	18-2833
3.0L	140		181	4	4	1983-1986	6229718 - B450800			18-1975-1	18-4009		18-1204-1	18-2833
3.0L	3.0L		181	4	4	1990-1994	C856559 & UP	18-1956-3		18-1975-1	18-4009		18-1204-1	18-2833
3.0L	3.0L		181	4	4	1987-1989	B450801 - C856558			18-1975-1	18-4009		18-1204-1	18-2833
3.0L	3.0L		181	4	4	1998-2003	L010042 - M679999	18-1956-3		18-1975-1	18-1990		18-1204-1	18-2833
3.0L	3.0L		181	4	4	2003-2010	M680000 & UP	18-1956-3		18-1975-1			18-0680	18-2833
3.0L	3.0L MPI / 3.0L EC		181	4	4	1990-1997	C856559 - K999999	18-1956-3		18-1975-1	18-1990		18-0680	18-2833
	150			4	4		1666495 - 2048046						18-2830-1	
	160			4	4		2048022 - 2770031						18-2830-1	
3.7L	165		224	4	4	1987	B434941 - B774251	Ⓜ		18-1937			18-0956-1	18-0881-1
3.7L	165		224	4	4	1987	B434941 - B774251	Ⓜ					18-0956-1	
3.7L	165		224	4	4		2770032 & up	18-1960-1				18-4009	18-2830-1	18-2833
3.7L	170		224	4	4	1985-1986	6916779 - B434940	Ⓜ		18-1937			18-0956-1	18-0881-1
3.7L	170		224	4	4	1985-1986	6916779 - B434940	Ⓜ					18-0956-1	18-0113-1
3.7L	180		224	4	4	1987	B436391 - B775248	Ⓜ		18-1937			18-0956-1	18-0881-1

- Ⓜ For engines with aluminum exhaust manifolds
- Ⓜ For engines with cast iron exhaust manifolds
- Ⓜ 3" (76mm) O.D. & 0 degree down angle
- Ⓜ 3" (76mm) O.D. & 15 degree down angle
- Ⓜ 4" (102mm) O.D.
- Ⓜ 2 piece exhaust manifold
- Ⓜ 1 piece exhaust manifold
- Ⓜ Has a rectangular elbow mounting bolt pattern
- Ⓜ Has a square elbow mounting bolt pattern

- Ⓜ In-line applications
- Ⓜ V-drive applications
- Ⓜ Standard rise
- Ⓜ 2" (51mm) rise
- Ⓜ 3" (76mm) rise
- Ⓜ 6" (152mm) rise
- Ⓜ Port
- Ⓜ Starboard
- Ⓜ Engines with risers or closed cooling may require a different gasket than listed

- Ⓜ Exhaust manifold with external water rail
- Ⓜ Exhaust manifold w/o external water rail
- Ⓜ 1 piece exhaust manifold is n/a. Engine must be converted to the 2 piece exhaust system
- Ⓜ Engines with easy drain system
- Ⓜ Engines with multi-point drain system
- Ⓜ Intermediate collector housing

MANIFOLD/MANIFOLD GASKET APPLICATION (Cont.)

Liter	Model	Note	CID	# Cyl.	Stroke	Year Range	Serial # Range	Exh. Manifold Port	Exh. Manifold Starboard	Exh. Elbow	End Cap Front	End Cap Rear	Manifold Gasket	Exh. Elbow Gasket
3.7L	180		224	4	4	1987	B436391 - B775248	Ⓔ					18-0956-1	18-0113-1
3.7L	190		224	4	4	1985-1986	6916779 - B436390	Ⓘ		18-1937			18-0956-1	18-0881-1
3.7L	190		224	4	4	1985-1986	6916779 - B436390	Ⓔ					18-0956-1	18-0113-1
3.7L	3.7L		224	4	4	1988-1989	B774252 & UP	Ⓘ		18-1937			18-0956-1	18-0881-1
3.7L	3.7L		224	4	4	1988-1989	B774252 & UP	Ⓔ					18-0956-1	
3.7L	3.7LX		224	4	4	1988-1989	B775249 & UP	Ⓘ		18-1937			18-0956-1	18-0881-1
3.7L	3.7LX		224	4	4	1988-1989	B775249 & UP	Ⓔ					18-0956-1	18-0113-1
	470		224	4	4	1976-1977	4208730 - 4625579						18-0956-1	18-2833
	470 MCM / 470 MIE		224	4	4	1977-1982	4625580 - 6218036						18-0956-1	18-2833
	470		224	4	4	1983-1984	6218037 - 6916778						18-0956-1	18-0113-1
	485		224	4	4	1980-1982	5685394 - 6218036						18-0956-1	
	488		224	4	4	1983-1984	6170297 - 6916778						18-0956-1	18-0113-1
	140		194	6	4	1963	1538930 - 1725960						18-2830-1	
	150		230	6	4	1964-1966	1666495 - 2048046						18-2830-1	
	160		250	6	4	1967-1969	2048022 - 2770031						18-2830-1	
	165		250	6	4	1970-1981	2770032 - 5813433	18-1960-1		18-1971	18-4009	18-1990	18-2830-1	18-2833
	200		292	6	4	1969	2453769 - 2712072	18-1960-1		18-1971		18-1990	18-2830-1	18-2833
	185	4bbl	229	6	4	1983-1984	6330183 - 6919655	18-1952-1	18-1952-1	18-1970-2			18-2909	18-0897
	175		262	6	4	1987	B527955 - B773242	18-1952-1	18-1952-1	18-1976-2			18-2909	18-0897
	185	2bbl	262	6	4	1985-1986	A331455 - B527954	18-1952-1	18-1952-1	18-1970-2 Ⓘ			18-2909	18-0897
	185	2bbl	262	6	4	1985-1986	A331455 - B527954	18-1952-1	18-1952-1	18-1976-2 Ⓢ			18-2909	18-0897
	205		262	6	4	1985-1986	A331455 - B527954	18-1952-1	18-1952-1	18-1970-2 Ⓘ			18-2909	18-0897
	205		262	6	4	1985-1986	A331455 - B527954	18-1952-1	18-1952-1	18-1976-2 Ⓢ			18-2909	18-0897
	205		262	6	4	1987	B527955 - B775129	18-1952-1	18-1952-1	18-1976-2			18-2909	18-0897
4.3L	262 MAG EFI GEN +		262	6	4	1996-1997	F803800 - K999999	18-1952-1 Ⓢ	18-1952-1 Ⓢ	18-1976-2 Ⓢ			18-2909	18-0897
4.3L	262 MAG EFI GEN +		262	6	4	1996-1997	F803800 - K999999	Ⓢ	Ⓢ	Ⓢ			18-2909	
4.3L	4.3L		262	6	4	1988-1996	B773243 - F802999	18-1952-1	18-1952-1	18-1976-2			18-2909	18-0897
4.3L	4.3L GEN +		262	6	4	1998-2002	L010044 - M614999	18-1952-1 Ⓢ	18-1952-1 Ⓢ	18-1976-2 Ⓢ			18-2909	18-2849-1
4.3L	4.3L GEN +		262	6	4	1998-2002	L010044 - M614999	Ⓢ	Ⓢ	Ⓢ			18-2909	
4.3L	4.3L GEN +		262	6	4	2002-2004	M615000 - W309999						18-2909	
4.3L	4.3L GEN +		262	6	4	2004-2010	W310000 & UP						18-2909	
4.3L	4.3L EFI GEN +		262	6	4	1998-2002	L012009 - M322780	18-1952-1 Ⓢ	18-1952-1 Ⓢ	18-1976-2 Ⓢ			18-2909	18-2849-1
4.3L	4.3L EFI GEN +		262	6	4	1998-2002	L01009 - M322780	Ⓢ	Ⓢ	Ⓢ			18-2909	
4.3L	4.3L MPI		262	6	4	2002	M300000 - M614999	18-1952-1	18-1952-1	18-1976-2			18-2909	18-0897 ♣
4.3L	4.3L MPI		262	6	4	2002	M300000 - M614999	18-1952-1	18-1952-1	18-1976-2			18-2909	18-2849-1 ♣
4.3L	4.3L MPI		262	6	4	2002-2004	M615000 - W309999						18-2909	
4.3L	4.3L MPI		262	6	4	2004-2010	W310000 & UP						18-2909	
4.3L	4.3L MPI / 4.3L EC		262	6	4	2010-2011	A637496 & UP			Ⓢ			18-2909	
4.3L	4.3L MPI / 4.3L EC		262	6	4	2010-2011	A637496 & UP			Ⓢ			18-2909	
4.3L	4.3LH GEN +		262	6	4	1998-2002	L010044 - M614999	18-1952-1 Ⓢ	18-1952-1 Ⓢ	18-1976-2 Ⓢ			18-2909	18-2849-1
4.3L	4.3LH GEN +		262	6	4	1998-2002	L010044 - M614999	Ⓢ	Ⓢ	Ⓢ			18-2909	
4.3L	4.3LH	4 bbl	262	6	4	1988-1996	B775130 - F802999	18-1952-1	18-1952-1	18-1976-2			18-2909	18-0897
4.3L	4.3LX GEN +	2bbl	262	6	4	1996-1997	F803800 - K999999	18-1952-1 Ⓢ	18-1952-1 Ⓢ	18-1976-2 Ⓢ			18-2909	18-0897
4.3L	4.3LX GEN +	2bbl	262	6	4	1996-1997	F803800 - K999999	Ⓢ	Ⓢ	Ⓢ			18-2909	
4.3L	4.3LXH GEN +		262	6	4	1996-1997	F803814 - K999999	18-1952-1 Ⓢ	18-1952-1 Ⓢ	18-1976-2 Ⓢ			18-2909	18-0897
4.3L	4.3LXH GEN +		262	6	4	1996-1997	F803814 - K999999	Ⓢ	Ⓢ	Ⓢ			18-2909	
5.0L	215		302	8	4	1970	2781153 - 3040410	18-1958-1	18-1962-1	18-1971	18-4009	18-1990	18-0183-1	18-2833
5.0L	215		302	8	4	1971-1972	3040411 - 3385720	18-1958-1	18-1962-1	18-1971	18-4009	18-4009	18-0183-1	18-2833
5.0L	215 MIE		302	8	4	1970	2781153 - 3040410	18-1958-1	18-1962-1		18-4009	18-1990	18-0183-1	18-2833
5.0L	215 MIE		302	8	4	1971-1972	3040411 - 3563181	18-1958-1	18-1962-1		18-4009	18-4009	18-0183-1	18-2833
5.0L	225	FORD	302	8	4	1973-1974	3385721 - 4166999	18-1958-1	18-1962-1	18-1971	18-4009	18-4009	18-0183-1	18-2833
5.0L	225 MIE	FORD	302	8	4	1973-1974	3385721 - 4176999	18-1958-1	18-1962-1		18-4009	18-4009	18-0183-1	18-2833
5.0L	888		302	8	4	1971-1977	3108723 - 4867829	18-1958-1	18-1962-1	18-1971	18-4009	18-4009	18-0183-1	18-2833

- Ⓘ For engines with aluminum exhaust manifolds
- Ⓢ For engines with cast iron exhaust manifolds
- Ⓢ 3" (76mm) O.D. & 0 degree down angle
- Ⓢ 3" (76mm) O.D. & 15 degree down angle
- Ⓢ 4" (102mm) O.D.
- Ⓢ 2 piece exhaust manifold
- Ⓢ 1 piece exhaust manifold
- Ⓢ Has a rectangular elbow mounting bolt pattern
- Ⓢ Has a square elbow mounting bolt pattern

- Ⓢ In-line applications
- Ⓢ V-drive applications
- Ⓢ Standard rise
- Ⓢ 2" (51mm) rise
- Ⓢ 3" (76mm) rise
- Ⓢ 6" (152mm) rise
- Ⓢ Port
- Ⓢ Starboard
- Ⓢ Engines with risers or closed cooling may require a different gasket than listed

- Ⓢ Exhaust manifold with external water rail
- Ⓢ Exhaust manifold w/o external water rail
- Ⓢ 1 piece exhaust manifold is n/a. Engine must be converted to the 2 piece exhaust system
- ♣ Engines with easy drain system
- ♣ Engines with multi-point drain system
- ♣ Intermediate collector housing

MANIFOLD/MANIFOLD GASKET APPLICATION (Cont.)

Liter	Model	Note	CID	# Cyl.	Stroke	Year Range	Serial # Range	Exh. Manifold Port	Exh. Manifold Starboard	Exh. Elbow	End Cap Front	End Cap Rear	Manifold Gasket	Exh. Elbow Gasket
	190		283	8	4	1963-1964	1564539 - 1730903						18-2949	
5.0L	198 MIE		305	8	4	1977	4776402 - 4931099	Ⓢ	Ⓢ	Ⓢ	18-4009	18-4009	18-2949	18-0885-1
5.0L	198 MIE		305	8	4	1977	4776402 - 4931099	18-1950-1 Ⓢ	18-1951-1 Ⓢ	Ⓢ	18-4009	18-4009	18-2949	18-2833
5.0L	200		305	8	4	1985-1987	6899058 - B525981	18-1953-2	18-1953-2	18-1970-2 Ⓢ			18-2949	18-0897
5.0L	200		305	8	4	1985-1987	6899058 - B525981	18-1953-2	18-1953-2	18-1976-2 Ⓢ			18-2949	18-0897
5.0L	200		305	8	4	1987	B525982 - B774444	18-1953-2	18-1953-2	18-1976-2			18-2949	18-0897
5.0L	228		305	8	4	1977	4765100 - 4888929				18-4009	18-4009	18-2949	18-0885-1
5.0L	228		305	8	4	1977-1982	4888930 - 6218461	18-1950-1	18-1951-1	18-1971	18-4009	18-4009	18-2949	18-2833
5.0L	228		305	8	4	1983-1984	6218462 - 6899268	18-1953-2	18-1953-2	18-1970-2 Ⓢ			18-2949	18-0897
5.0L	228		305	8	4	1983-1984	6218462 - 6899268	18-1953-2	18-1953-2	18-1976-2 Ⓢ			18-2949	18-0897
5.0L	228 TR		305	8	4	1977-1978	4888930 - 5170008	18-1950-1	18-1951-1	18-1971	18-4009	18-4009	18-2949	18-2833
5.0L	228 TR		305	8	4	1977-1978	4888930 - 5170008	18-1950-1	18-1951-1	18-1971	18-4009	18-4009	18-2949	18-2833
5.0L	228 MIE		305	8	4	1977	4765100 - 4888929				18-4009	18-4009	18-2949	18-0885-1
5.0L	228 MIE		305	8	4	1977-1980	4888930 - 5907057	18-1950-1	18-1951-1		18-4009	18-4009	18-2949	18-2833
5.0L	230		305	8	4	1985-1987	6899269 - B525981	18-1953-2	18-1953-2	18-1970-2 Ⓢ			18-2949	18-0897
5.0L	230		305	8	4	1985-1987	6899269 - B525981	18-1953-2	18-1953-2	18-1976-2 Ⓢ			18-2949	18-0897
5.0L	230		305	8	4	1987	B525982 - B773739	18-1953-2	18-1953-2	18-1976-2			18-2949	18-0897
5.0L	230 MIE		305	8	4	1981-1987	5907058 - B788151	18-1953-2	18-1953-2	18-1974-1 Ⓢ			18-2949	18-0897
5.0L	230 MIE		305	8	4	1981-1987	5907058 - B788151	18-1953-2	18-1953-2	18-1970-2 Ⓢ			18-2949	18-0897
5.0L	230 MIE		305	8	4	1981-1987	5907058 - B788151	18-1953-2	18-1953-2	18-1976-2 Ⓢ			18-2949	18-0897
5.0L	5.0L		305	8	4	1988-1995	B774445 - F600999	18-1953-2	18-1953-2	18-1976-2			18-2949	18-0897
5.0L	5.0L GEN +		305	8	4	1988-2002	L015751 - M599999	18-1953-2	18-1953-2	18-1976-2			18-2949	
5.0L	5.0L GEN +		305	8	4	1988-2002	M600000 - W309999						18-2949	
5.0L	5.0L GEN +		305	8	4	2004-2010	W310000 & UP						18-2949	
5.0L	5.0L EFI GEN +		305	8	4	1998-2001	L012052 - M299999	18-1953-2	18-1953-2	18-1976-2			18-2949	18-2849-1
5.0L	5.0L MIE		305	8	4	1988	B788152 - C396832	18-1953-2	18-1953-2	18-1976-2			18-2949	18-0897
5.0L	5.0L MPI		305	8	4	2002	M300000 - M599999	18-1953-2	18-1953-2	18-1976-2			18-2949	18-0897
5.0L	5.0L MPI		305	8	4	2002-2004	M600000 - W309999						18-2949	
5.0L	5.0L MPI		305	8	4	2004-2010	W310000 & UP						18-2949	
5.0L	5.0LX		305	8	4	1988-1995	B773740 - F600900	18-1953-2	18-1953-2	18-1976-2			18-2949	18-0897
5.0L	898		305	8	4	1977-1982	4762210 - 6218461	Ⓢ	Ⓢ	Ⓢ	18-4009	18-4009	18-2949	18-0885-1
5.0L	898		305	8	4	1977-1982	4762210 - 6218461	18-1950-1 Ⓢ	18-1951-1 Ⓢ	Ⓢ	18-4009	18-4009	18-2949	18-2833
5.0L	898		305	8	4	1983-1984	6218462 - 6899057	18-1953-2	18-1953-2	18-1970-2			18-2949	18-0897
5.0L	898		305	8	4	1983-1984	6218462 - 6899057	18-1953-2	18-1953-2	18-1976-2 Ⓢ			18-2949	18-0897
	225	GM	327	8	4	1963-1968	1539620 - 2399397						18-2949	
	225	GM	327	8	4	1968-1969	2399398 - 2694014				18-4009	18-1990	18-2949	18-0885-1
	225 MIE	GM	327	8	4	1968	2278647 - 2399307						18-2949	
	225 MIE	GM	327	8	4	1968-1969	2399398 - 2694014				18-4009	18-1990	18-2949	18-0885-1
	250		327	8	4	1968-1969	2314301 - 2639854				18-4009	18-1990	18-2949	18-0885-1
	250 MIE		327	8	4	1968-1969	2314301 - 2639854				18-4009	18-1990	18-2949	18-0885-1
5.7L	250		350	8	4	1977	4768000 - 4908849	Ⓢ	Ⓢ	Ⓢ	18-4009	18-4009	18-2949	18-0885-1
5.7L	250		350	8	4	1977	4768000 - 4908849	18-1950-1 Ⓢ	18-1951-1 Ⓢ	18-1971 Ⓢ	18-4009	18-4009	18-2949	18-2833
5.7L	255	GM	350	8	4	1975-1976	4175500 - 4499060				18-4009	18-1990	18-2949	18-0885-1
5.7L	255	GM	350	8	4	1976	4499061 - 4767999	18-1950-1	18-1951-1	18-1971	18-4009	18-4009	18-2949	18-2833
5.7L	255 MIE	GM	350	8	4	1975-1976	4175500 - 4499060				18-4009	18-1990	18-2949	18-0885-1
5.7L	255 MIE	GM	350	8	4	1976-1980	4499061 - 5907057	18-1950-1	18-1951-1		18-4009	18-4009	18-2949	18-2833
5.7L	260		350	8	4	1978-1982	4908850 - 6218461	18-1950-1	18-1951-1	18-1971	18-4009	18-4009	18-2949	18-2833
5.7L	260		350	8	4	1983-1987	6218462 - B773304	18-1953-2	18-1953-2	18-1970-2 Ⓢ			18-2949	18-0897
5.7L	260		350	8	4	1983-1987	6218462 - B773304	18-1953-2	18-1953-2	18-1976-2 Ⓢ			18-2949	18-0897
5.7L	260 MIE		350	8	4	1981-1987	5907058 - B788151	18-1953-2	18-1953-2	18-1974-1 Ⓢ			18-2949	18-0897
5.7L	260 MIE		350	8	4	1981-1987	5907058 - B788151	18-1953-2	18-1953-2	18-1970-2 Ⓢ			18-2949	18-0897
5.7L	260 MIE		350	8	4	1981-1987	5907058 - B788151	18-1953-2	18-1953-2	18-1976-2 Ⓢ			18-2949	18-0897

- Ⓢ For engines with aluminum exhaust manifolds
- Ⓢ For engines with cast iron exhaust manifolds
- Ⓢ 3" (76mm) O.D. & 0 degree down angle
- Ⓢ 3" (76mm) O.D. & 15 degree down angle
- Ⓢ 4" (102mm) O.D.
- Ⓢ 2 piece exhaust manifold
- Ⓢ 1 piece exhaust manifold
- Ⓢ Has a rectangular elbow mounting bolt pattern
- Ⓢ Has a square elbow mounting bolt pattern

- Ⓢ In-line applications
- Ⓢ V-drive applications
- Ⓢ Standard rise
- Ⓢ 2" (51mm) rise
- Ⓢ 3" (76mm) rise
- Ⓢ 6" (152mm) rise
- Ⓢ Port
- Ⓢ Starboard
- Ⓢ Engines with risers or closed cooling may require a different gasket than listed

- Ⓢ Exhaust manifold with external water rail
- Ⓢ Exhaust manifold w/o external water rail
- Ⓢ 1 piece exhaust manifold is n/a. Engine must be converted to the 2 piece exhaust system
- Ⓢ Engines with easy drain system
- Ⓢ Engines with multi-point drain system
- Ⓢ Intermediate collector housing

MANIFOLD/MANIFOLD GASKET APPLICATION (Cont.)

Liter	Model	Note	CID	# Cyl.	Stroke	Year Range	Serial # Range	Exh. Manifold Port	Exh. Manifold Starboard	Exh. Elbow	End Cap Front	End Cap Rear	Manifold Gasket	Exh. Elbow Gasket
5.7L	270		350	8	4	1969-1972	2851074 - 3385720				18-4009	18-1990	18-2949	18-0885-1
5.7L	270 MIE		350	8	4	1969-1972	2851074 - 3077735				18-4009	18-1990	18-2949	18-0885-1
5.7L	280 TRS		350	8	4	1975-1976	4176250 - 4770199	Ⓔ	Ⓔ	Ⓔ	18-4009	18-1990	18-2949	18-0885-1
5.7L	280 TRS		350	8	4	1975-1976	4176250 - 4770199	18-1950-1 Ⓔ	18-1951-1 Ⓔ	Ⓔ	18-4009	18-4009	18-2949	18-2833
5.7L	300		350	8	4	1985-1986	6668677 - B4300367	18-1953-2	18-1953-2				18-2949	18-2849-1
5.7L	320 EFI		350	8	4	1987-1989	A543604 - C622418	18-1953-2	18-1953-2	18-1976-2			18-2949	18-0897
5.7L	350 MAG ALPHA		350	8	4	1986-1997	A635178 - K999999	18-1953-2	18-1953-2	18-1976-2			18-2949	18-0897
5.7L	350 MAG ALPHA /		350	8	4	1996-1997	F800300 - K999999	18-1953-2	18-1953-2	18-1976-2			18-2949	18-0897
	350 MAG EFI													
5.7L	350 MAG BRAVO /		350	8	4	1995	F415189 - F601999	18-1953-2	18-1953-2	18-1976-2			18-2949	18-0897
	350 MAG MPI													
5.7L	350 MAG BRAVO GEN + /		350	8	4	1996-1997	F602000 - K999999	18-1953-2	18-1953-2	18-1976-2			18-2949	18-0897
	350 MAG MPI GEN +													
5.7L	350 MAG EFI /		350	8	4	1994-1996	F215561 - F820706	18-1953-2	18-1953-2	18-1976-2			18-2949	18-0897
	350 MAG SKI													
5.7L	350 MAG EFI GEN + /		350	8	4	1996-1997	F820707 - K999999	18-1953-2	18-1953-2	18-1976-2			18-2949	18-0897
	350 MAG SKI GEN +													
5.7L	350 MAG MPI		350	8	4	1998-2001	L010019 - M299999	18-1953-2	18-1953-2	18-1976-2			18-2949	18-2849-1
5.7L	350 MAG MPI		350	8	4	2002	M300000 - M599999	18-1953-2	18-1953-2	18-1976-2			18-2949	18-0897
5.7L	350 MAG MPI		350	8	4	2002-2004	M600000 - W309999						18-2949	
5.7L	350 MAG MPI		350	8	4	2004-2010	W310000 & UP						18-2949	
5.7L	350 MAG MPI /		350	8	4	2002	M300000 - M599999	18-1953-2	18-1953-2	18-1976-2			18-2949	18-2849-1
	350 MAG HORIZON													
5.7L	350 MAG MPI /		350	8	4	2002-2004	M600000 - W309999						18-2949	
	350 MAG HORIZON													
5.7L	350 MAG MPI /		350	8	4	2004-2007	W310000 - A299999						18-2949	
	350 MAG HORIZON													
5.7L	350 MAG MPI /		350	8	4	1999-2001	L304700 - M299999	18-1953-2	18-1953-2	18-1976-2			18-2949	18-2849-1
	350 MAG HORIZON / 350 MAG MIE													
5.7L	350 MAG MPI /		350	8	4	2002	M300000 - M316999	18-1953-2	18-1953-2	18-1976-2			18-2949	18-2849-1
	350 MAG HORIZON / 350 MAG MIE													
5.7L	350 MAG MPI /		350	8	4	2002-2007	M317000 - A089999						18-2949	
	350 MAG HORIZON / 350 MAG MIE													
5.7L	350 MAG MPI /		350	8	4	1998-2001	L002008 - M299999	18-1953-2	18-1953-2	18-1976-2			18-2949	18-2849-1
	350 MAG MIE													
5.7L	350 MAG MPI		350	8	4	2002	M300000 - M316999	18-1953-2	18-1953-2	18-1976-2			18-2949	18-0897
	/ 350 MAG MIE													
5.7L	350 MAG MPI		350	8	4	2002-2007	M317000 - A089999						18-2949	
	/ 350 MAG MIE													
5.7L	350 MAG MPI		350	8	4	1995-1996	F350583 - F799999	18-1953-2	18-1953-2	18-1976-2			18-2949	
	/ 350 MAG SKI													
5.7L	350 MAG MPI GEN +		350	8	4	1998-2001	L002600 - M299999	18-1953-2	18-1953-2	18-1976-2			18-2949	18-2849-1
	/ 350 MAG SKI GEN +													
5.7L	350 MAG MPI GEN +		350	8	4	2002	M300000 - M316999	18-1953-2	18-1953-2	18-1976-2			18-2949	18-0897
	/ 350 MAG SKI GEN +													
5.7L	350 MAG MPI GEN +		350	8	4	2002-2007	M317000 - A089999			Ⓔ			18-2949	18-0897
	/ 350 MAG SKI GEN +													
5.7L	350 MAG MPI GEN +		350	8	4	2002-2007	M317000 - A089999			Ⓔ			18-2949	
	/ 350 MAG SKI GEN +													
5.7L	350 MAG SKI		350	8	4	1991-1997	D505450 - K999999	18-1953-2	18-1953-2	18-1976-2			18-2949	18-0897
5.7L	5.7L		350	8	4	1988-1997	B773305 - K999999	18-1953-2	18-1953-2	18-1976-2			18-2949	18-0897

- Ⓔ For engines with aluminum exhaust manifolds
- Ⓕ For engines with cast iron exhaust manifolds
- Ⓖ 3" (76mm) O.D. & 0 degree down angle
- Ⓗ 3" (76mm) O.D. & 15 degree down angle
- Ⓖ 4" (102mm) O.D.
- Ⓗ 2 piece exhaust manifold
- Ⓖ 1 piece exhaust manifold
- Ⓗ Has a rectangular elbow mounting bolt pattern
- Ⓖ Has a square elbow mounting bolt pattern

- Ⓔ In-line applications
- Ⓕ V-drive applications
- Ⓖ Standard rise
- Ⓗ 2" (51mm) rise
- Ⓖ 3" (76mm) rise
- Ⓗ 6" (152mm) rise
- Ⓔ Port
- Ⓕ Starboard
- Ⓖ Engines with risers or closed cooling may require a different gasket than listed

- Ⓔ Exhaust manifold with external water rail
- Ⓕ Exhaust manifold w/o external water rail
- Ⓖ 1 piece exhaust manifold is n/a. Engine must be converted to the 2 piece exhaust system
- Ⓗ Engines with easy drain system
- Ⓖ Engines with multi-point drain system
- Ⓕ Intermediate collector housing

MANIFOLD/MANIFOLD GASKET APPLICATION (Cont.)

Liter	Model	Note	CID	# Cyl.	Stroke	Year Range	Serial # Range	Exh. Manifold Port	Exh. Manifold Starboard	Exh. Elbow	End Cap Front	End Cap Rear	Manifold Gasket	Exh. Elbow Gasket
5.7L	5.7L GEN +		350	8	4	1998-2002	L010037 - M599999	18-1953-2	18-1953-2	18-1976-2			18-2949	18-2849-1
5.7L	5.7L GEN +		350	8	4	2002-2004	M600000 - W309999						18-2949	
5.7L	5.7L GEN +		350	8	4	2004-2010	W310000 & UP						18-2949	
5.7L	5.7L EFI		350	8	4	1995-1997	F225560 - K999999	18-1953-2	18-1953-2	18-1976-2			18-2949	18-0897
5.7L	5.7L EFI GEN +		350	8	4	1998-2001	L010035 - M299999	18-1953-2	18-1953-2	18-1976-2			18-2949	18-2849-1
5.7L	5.7L EFI / 5.7L MIE		350	8	4	1997	K040300 - K999999	18-1953-2	18-1953-2	18-1976-2			18-2949	18-0897
5.7L	5.7L MIE		350	8	4	1988-1997	B788152 - K999999	18-1953-2	18-1953-2	18-1976-2			18-2949	18-0897
5.7L	5.7L MIE GEN +		350	8	4	1998-2002	L002003 - M316999	18-1953-2	18-1953-2	18-1976-2			18-2949	18-2849-1
5.7L	5.7L MIE GEN +		350	8	4	2002-2010	M317000 & UP						18-2949	
5.7L	5.7L MPI / 5.7L MIE		350	8	4	2008-2010	A090000 & UP						18-2949	
5.7L	5.7L MPI / 5.7L SKI		350	8	4	2008-2010	A090000 & UP			Ⓜ			18-2949	
5.7L	5.7L MPI / 5.7L SKI		350	8	4	2008-2010	A090000 & UP			Ⓜ			18-2949	
5.7L	5.7L SKI		350	8	4	1985-1995	A338553 - F775199	18-1953-2	18-1953-2	18-1970-2 Ⓜ			18-2949	18-0897
5.7L	5.7L SKI		350	8	4	1985-1995	A338553 - F775199	18-1953-2	18-1953-2	18-1976-2 Ⓜ			18-2949	18-0897
5.7L	5.7L SKI		350	8	4	1996-1997	F775200 - K999999	18-1953-2	18-1953-2	18-1976-2			18-2949	18-0897
5.7L	5.7L SKI		350	8	4	1998-2002	L002005 - M316999	18-1953-2	18-1953-2	18-1976-2			18-2949	18-2849-1
5.7L	5.7L SKI		350	8	4	2002-2010	M317000 & UP						18-2949	
5.7L	5.7LX		350	8	4	1996-1997	F601000 - K999999	18-1953-2	18-1953-2	18-1976-2			18-2949	18-0897
5.7L	5.7LX BRAVO EFI		350	8	4	1996-1997	F800300 - K999999	18-1953-2	18-1953-2	18-1976-2			18-2949	18-0897
5.7L	5.7LX EFI		350	8	4	1996-1997	F752400 - K999999	18-1953-2	18-1953-2	18-1976-2			18-2949	18-0897
5.7L	BLACK SCORPION SKI		350	8	4	1996-1997	F800000 - K999999	18-1953-2	18-1953-2	18-1976-2			18-2949	18-0897
5.7L	BLACK SCORPION SKI		350	8	4	2003-2007	M391600 - W698432			Ⓜ			18-2949	
5.7L	BLACK SCORPION SKI		350	8	4	2003-2007	M391600 - W698432			Ⓜ			18-2949	
5.7L	SCORPION 350		350	8	4	2008-2010	W698433 & UP			Ⓜ			18-2949	
5.7L	SCORPION 350		350	8	4	2008-2010	W698433 & UP			Ⓜ			18-2949	
6.2L	233		351	8	4	1975-1977	4173000 - 4902304	18-1958-1	18-1962-1	18-1971	18-4009	18-4009	18-0183-1	18-2833
6.2L	233 MIE		351	8	4	1975-1977	4173000 - 4902304	18-1958-1	18-1962-1	N.L.A.	18-4009	18-4009	18-0183-1	18-2833
6.2L	233 MIE		351	8	4	1975-1977	4173000 - 4902304	18-1958-1	18-1962-1	N.L.A.	18-1990 □	18-4009	18-0183-1	18-2833
6.2L	255	FORD	351	8	4	1973-1974	3258728 - 4175499	18-1958-1	18-1962-1	18-1971	18-4009	18-4009	18-0183-1	18-2833
6.2L	255 MIE	FORD	351	8	4	1973-1974	3258728 - 4175499	18-1958-1	18-1962-1		18-4009	18-4009	18-0183-1	18-2833
6.2L	225 MIE	FORD	351	8	4	1973-1974	3258728 - 4175499	18-1958-1	18-1962-1		18-1990 □	18-4009	18-0183-1	18-2833
6.2L	377 MAG		377	8	4	2008-2010	A300000 & UP						18-2949	
6.2L	377 SCORPION MCM		377	8	4	1999-2005	L416146 - M907201	18-1953-2	18-1953-2	18-1976-2			18-2949	18-2849-1
6.2L	377 SCORPION SKI		377	8	4	1997-1998	K000656 - L600314	18-1953-2	18-1953-2	18-1976-2			18-2949	18-0897
6.2L	MX 6.2L MPI		377	8	4	2000-2001	L680003 - M299999	18-1953-2	18-1953-2	18-1976-2			18-2949	18-2849-1
6.2L	MX 6.2L MPI		377	8	4	2002	M300000 - M599999	18-1953-2	18-1953-2	18-1976-2			18-2949	18-0897
6.2L	MX 6.2L MPI		377	8	4	2002-2004	M600000 - W309999						18-2949	
6.2L	MX 6.2L MPI		377	8	4	2004-2007	W310000 - A299999						18-2949	
6.2L	MX 6.2L MPI / MX 6.2L HORIZON		377	8	4	2002	M300000 - M599999	18-1953-2	18-1953-2	18-1976-2			18-2949	18-2849-1
6.2L	MX 6.2L MPI / MX 6.2L HORIZON		377	8	4	2002-2004	M600000 - W309999						18-2949	
6.2L	MX 6.2L MPI / MX 6.2L HORIZON		377	8	4	2004-2007	W310000 - A299999						18-2949	
6.2L	MX 6.2L MPI / MX 6.2L HORIZON / MX 6.2L MIE		377	8	4	2002	M300000 - M316999	18-1953-2	18-1953-2	18-1976-2			18-2949	18-2849-1
6.2L	MX 6.2L MPI / MX 6.2L HORIZON / MX 6.2L MIE		377	8	4	2002-2007	M317000 - A089999						18-2949	
6.2L	MX 6.2L MPI / MX 6.2L MIE		377	8	4	1999-2001	L670000 - M299999	18-1953-2	18-1953-2	18-1976-2			18-2949	18-2849-1
6.2L	MX 6.2L MPI / MX 6.2L MIE		377	8	4	2002	M300000 - M316999	18-1953-2	18-1953-2	18-1976-2			18-2949	18-0897
6.2L	MX 6.2L MPI / MX 6.2L MIE		377	8	4	2002-2010	M317000 & UP						18-2949	
6.2L	MX 6.2L MPI / MX 6.2L SKI		377	8	4	2002-2007	M317000 - A089999						18-2949	
6.2L	MX 6.2L MPI / MX 6.2L SKI		377	8	4	2002-2007	M317000 - A089999						18-2949	
6.2L	MX 6.2L BLACK SCORPION SKI		377	8	4	2001-2003	L670015 - M391599	18-1953-2	18-1953-2	18-1976-2			18-2949	18-2849-1

- Ⓜ For engines with aluminum exhaust manifolds
- Ⓜ For engines with cast iron exhaust manifolds
- Ⓜ 3" (76mm) O.D. & 0 degree down angle
- Ⓜ 3" (76mm) O.D. & 15 degree down angle
- Ⓜ 4" (102mm) O.D.
- Ⓜ 2 piece exhaust manifold
- Ⓜ 1 piece exhaust manifold
- Ⓜ Has a rectangular elbow mounting bolt pattern
- Ⓜ Has a square elbow mounting bolt pattern

- Ⓜ In-line applications
- Ⓜ V-drive applications
- Ⓜ Standard rise
- Ⓜ 2" (51mm) rise
- Ⓜ 3" (76mm) rise
- Ⓜ 6" (152mm) rise
- Ⓜ Port
- Ⓜ Starboard
- Ⓜ Engines with risers or closed cooling may require a different gasket than listed

- Ⓜ Exhaust manifold with external water rail
- Ⓜ Exhaust manifold w/o external water rail
- Ⓜ 1 piece exhaust manifold is nla. Engine must be converted to the 2 piece exhaust system
- Ⓜ Engines with easy drain system
- Ⓜ Engines with multi-point drain system
- Ⓜ Intermediate collector housing

MANIFOLD/MANIFOLD GASKET APPLICATION (Cont.)

Liter	Model	Note	CID	# Cyl.	Stroke	Year Range	Serial # Range	Exh. Manifold Port	Exh. Manifold Starboard	Exh. Elbow	End Cap Front	End Cap Rear	Manifold Gasket	Exh. Elbow Gasket
6.2L	MX 6.2L BLACK SCORPION SKI		377	8	4	2003-2007	M391600 - W698432						18-2949	
6.2L	MX 6.2L BLACK SCORPION SKI		377	8	4	2003-2007	M391600 - W698432						18-2949	
6.2L	SCORPION 377		377	8	4	2008-2010	W698433 & UP						18-2949	
6.2L	SCORPION 377		377	8	4	2008-2010	W698433 & UP						18-2949	
7.4L	325		427	8	4	1968	2278747 - 2313964						18-0418	
7.4L	325		427	8	4	1968-1974	2313965 - 3780449				18-4009	18-1990	18-0418	18-0885-1
7.4L	325 MIE		427	8	4	1968	2278747 - 2313964						18-0418	
7.4L	325 MIE		427	8	4	1968-1974	2313965 - 3780449				18-4009	18-1990	18-0418	18-0885-1
7.4L	330		454	8	4	1977-1981	4623115 - 6083144				18-4009	18-4009	18-0418	18-0885-1
7.4L	330		454	8	4	1982-1987	6083145 - B816540	18-1957-2	18-1957-2	18-1970-2 ①			18-0418	18-0897
7.4L	330		454	8	4	1982-1987	6083145 - B816540	18-1957-2	18-1957-2	18-1976-2 ②			18-0418	18-0897
7.4L	330 MIE		454	8	4	1977-1981	4623115 - 6083144				18-4009	18-4009	18-0418	18-0885-1
7.4L	340 MIE W/BW		454	8	4	1981-1987	5889914 - B788365	18-1957-2	18-1957-2	18-1974-1 ③			18-0418	18-0897
7.4L	340 MIE W/BW		454	8	4	1981-1987	5889914 - B788365	18-1957-2	18-1957-2	18-1970-2 ④			18-0418	18-0897
7.4L	340 MIE W/BW		454	8	4	1981-1987	5889914 - B788365	18-1957-2	18-1957-2	18-1976-2 ⑤			18-0418	18-0897
7.4L	350 MIE		454	8	4	1974-1975	3780450 - 4501640				18-4009	18-1990	18-0418	18-0885-1
7.4L	350 MIE		454	8	4	1976	4501641 - 4623109				18-4009	18-4009	18-0418	18-0885-1
7.4L	370 TRS		454	8	4	1978-1985	4179554 - 6721527				18-4009	18-1990	18-0418	18-0885-1
7.4L	370 TRS		454	8	4	1985-1987	6721528 - B714586	18-1957-2	18-1957-2	18-1976-2			18-0418	18-2849-1
7.4L	400 TRS		454	8	4	1980-1986	4179554 - B457644				18-4009	18-1990	18-0418	18-0885-1
7.4L	420		454	8	4	1987-1989	A398941 - B622418						18-0418	
7.4L	425		454	8	4	1990-1992	G398941 - D937011						18-0418	
7.4L	440 TRS		454	8	4	1983-1986	4179554 - B485220						18-0418	
7.4L	450		454	8	4	1995-1996	F347100 - F347277			②			18-0418	
7.4L	450		454	8	4	1995-1996	F347100 - F347277			④			18-0418	
7.4L	450		454	8	4	1995-1996	F347100 - F347277			⑤			18-0418	
7.4L	454 MAG ALPHA		454	8	4	1986-1988	A631894 - B785148	18-1957-2	18-1957-2	18-1976-2			18-0418	18-0897
7.4L	454 MAG BRAVO		454	8	4	1988-1997	B721206 - K999999	18-1957-2	18-1957-2	18-1976-2			18-0418	18-0897
7.4L	454 MAG EFI		454	8	4	1994-1996	F115700 - F802349	18-1957-2	18-1957-2	18-1976-2			18-0418	18-0897
7.4L	454 MAG EFI / 454 MAG SKI		454	8	4	1995-1996	F215800 - F820099	18-1957-2	18-1957-2	18-1976-2			18-0418	18-0897
7.4L	454 MAG MPI		454	8	4	1996-1997	F802350 - K999999	18-1957-2	18-1957-2	18-1976-2			18-0418	18-0897
7.4L	454 MAG MPI		454	8	4	1998-2001	L010029 - M0224999	18-1957-2	18-1957-2	18-1976-2			18-0418	18-2849-1
7.4L	454 MAG MPI / 454 MAG HORIZON / 454 MAG MIE		454	8	4	1999-2001	L086050 - L674000	18-1957-2	18-1957-2	18-1976-2			18-0418	18-2849-1
7.4L	454 MAG MPI / 454 MAG SKI		454	8	4	1996-1997	F820100 - K999999	18-1957-2	18-1957-2	18-1976-2			18-0418	18-0897
7.4L	525 SC W/BRAVO		454	8	4	1991-1996	D456000 - F877734			②			18-0418	
7.4L	525 SC W/BRAVO		454	8	4	1991-1996	D456000 - F877734			④			18-0418	
7.4L	525 SC W/BRAVO		454	8	4	1991-1996	D456000 - F877734			⑤			18-0418	
7.4L	525 SC W/SSM		454	8	4	1991-1996	D456000 - F877734			②			18-0418	
7.4L	525 SC W/SSM		454	8	4	1991-1996	D456000 - F877734			④			18-0418	
7.4L	525 SC W/SSM		454	8	4	1991-1996	D456000 - F877734			⑤			18-0418	
7.4L	7.4L BRAVO		454	8	4	1988-1997	B771113 - K999999	18-1957-2	18-1957-2	18-1976-2			18-0418	18-0897
7.4L	7.4L EFI / 7.4L MIE		454	8	4	1996-1997	F874815 - K999999	18-1957-2	18-1957-2	18-1976-2			18-0418	18-0897
7.4L	7.4L MIE W/BW		454	8	4	1988-1992	B788366 - D715493	18-1957-2	18-1957-2	18-1974-1 ③			18-0418	18-0897
7.4L	7.4L MIE W/BW		454	8	4	1988-1992	B788366 - D715493	18-1957-2	18-1957-2	18-1970-2 ④			18-0418	18-0897
7.4L	7.4L MIE W/BW		454	8	4	1988-1992	B788366 - D715493	18-1957-2	18-1957-2	18-1976-2 ⑤			18-0418	18-0897
7.4L	7.4L MIE W/HURTH		454	8	4	1989-1992	C391564 - D715493	18-1957-2	18-1957-2	18-1976-2			18-0418	18-0897
7.4L	7.4L MIE		454	8	4	1992-1997	D715494 - K999999	18-1957-2	18-1957-2	18-1976-2			18-0418	18-0897
7.4L	7.4L MPI		454	8	4	1998-2001	L010003 - M024330	18-1957-2	18-1957-2	18-1976-2			18-0418	18-2849-1
7.4L	7.4L MPI / 7.4L MIE		454	8	4	1995-1997	F563052 - K999999	18-1957-2	18-1957-2	18-1976-2			18-0418	18-0897
7.4L	7.4L MPI / 7.4L MIE		454	8	4	1998-2001	L002006 - L674613	18-1957-2	18-1957-2	18-1976-2			18-0418	18-2849-1

- ① For engines with aluminum exhaust manifolds
- ② For engines with cast iron exhaust manifolds
- ③ 3" (76mm) O.D. & 0 degree down angle
- ④ 3" (76mm) O.D. & 15 degree down angle
- ⑤ 4" (102mm) O.D.
- ⑥ 2 piece exhaust manifold
- ⑦ 1 piece exhaust manifold
- ⑧ Has a rectangular elbow mounting bolt pattern
- ⑨ Has a square elbow mounting bolt pattern

- ⑩ In-line applications
- ⑪ V-drive applications
- ⑫ Standard rise
- ⑬ 2" (51mm) rise
- ⑭ 3" (76mm) rise
- ⑮ 6" (152mm) rise
- ⑯ Port
- ⑰ Starboard
- ⑱ Engines with risers or closed cooling may require a different gasket than listed

- ⑲ Exhaust manifold with external water rail
- ⑳ Exhaust manifold w/o external water rail
- ㉑ 1 piece exhaust manifold is n/a. Engine must be converted to the 2 piece exhaust system
- ㉒ Engines with easy drain system
- ㉓ Engines with multi-point drain system
- ㉔ Intermediate collector housing

MANIFOLD/MANIFOLD GASKET APPLICATION (Cont.)

Liter	Model	Note	CID	# Cyl.	Stroke	Year Range	Serial # Range	Exh. Manifold Port	Exh. Manifold Starboard	Exh. Elbow	End Cap Front	End Cap Rear	Manifold Gasket	Exh. Elbow Gasket
7.4L	7.4LX BRAVO EFI		454	8	4	1996-1997	F820000 - K999999	18-1957-2	18-1957-2	18-1976-2			18-0418	18-0897
7.4L	7.4LX BRAVO MPI		454	8	4	1996-1997	F602010 - K999999	18-1957-2	18-1957-2	18-1976-2			18-0418	18-0897
	390 MCM / 390 MIE		482	8	4	1969-1970	2781129 - 3042731				18-1990	18-1990	18-0418	18-0885-1
	496 MAG / 496 HO		496	8	4	2001-2003	M025000 - M687143		⑨	②			18-0418	
	496 MAG / 496 HO		496	8	4	2001-2010	M0225000 & UP		⑩	②			18-0418	
	8.1S / 8.1 HO / 8.1 MIE		496	8	4	2001-2003	M026000 - M319190		⑨	②			18-0418	
	8.1S / 8.1 HO / 8.1 MIE		496	8	4	2001-2010	M026000 & UP		⑩	②			18-0418	
8.2L	465		502	8	4	1990-1994	C849992 - F213244			②			18-0418	
8.2L	465		502	8	4	1990-1994	C849992 - F213244			④			18-0418	
8.2L	465		502	8	4	1990-1994	C849992 - F213244			⑤			18-0418	
8.2L	500 BRAVO		502	8	4	1994-1998	F213293 - L001772			②			18-0418	
8.2L	500 BRAVO		502	8	4	1994-1998	F213293 - L001772			④			18-0418	
8.2L	500 BRAVO		502	8	4	1994-1998	F213293 - L001772			⑤			18-0418	
8.2L	500 GEN +		502	8	4	1999	L414639 - L601036			②			18-0418	
8.2L	500 GEN +		502	8	4	1999	L414639 - L601036			④			18-0418	
8.2L	500 GEN +		502	8	4	1999	L414639 - L601036			⑤			18-0418	
8.2L	502 MAG BRAVO		502	8	4	1990-1993	C878221 - F114528	18-1957-2	18-1957-2	18-1976-2			18-0418	18-0897
8.2L	502 MAG EFI		502	8	4	1993-1995	D840650 - F802599	18-1957-2	18-1957-2	18-1976-2			18-0418	18-0897
8.2L	502 MAG MPI		502	8	4	1996-1997	F802600 - K999999	18-1957-2	18-1957-2	18-1976-2			18-0418	18-0897
8.2L	502 MAG MPI		502	8	4	1998-2001	L017000 - M024999	18-1957-2	18-1957-2	18-1976-2			18-0418	18-2849-1
8.2L	600 SC		502	8	4	1991-1996	D456489 - F877642						18-0418	
8.2L	600 SC		502	8	4	1991-1996	D456489 - F877642						18-0418	
8.2L	8.2L MIE		502	8	4	1990-1996	C878221 - F819619	18-1957-2	18-1957-2	18-1976-2			18-0418	18-0897
8.2L	8.2L MIE / 8.2L MPI		502	8	4	1996-1997	F819620 - K999999	18-1957-2	18-1957-2	18-1976-2			18-0418	18-0897
8.2L	8.2L MIE / 8.2L MPI		502	8	4	1998-2001	L002450 - L674200	18-1957-2	18-1957-2	18-1976-2			18-0418	18-2849-1
	500 BULLDOG W/BRAVO		540	8	4	1990-1998	C577254 - L001607			②			18-0418	
	500 BULLDOG W/BRAVO		540	8	4	1990-1998	C577254 - L001607			④			18-0418	
	500 BULLDOG W/BRAVO		540	8	4	1990-1998	C577254 - L001607			⑤			18-0418	
	500 BULLDOG W/BRAVO		540	8	4	1999-2001	L414620 - M050281			②			18-0418	
	500 BULLDOG W/BRAVO		540	8	4	1999-2001	L414620 - M050281			④			18-0418	
	500 BULLDOG W/BRAVO		540	8	4	1999-2001	L414620 - M050281			⑤			18-0418	
	500 BULLDOG W/SSM		540	8	4	1990-2001	C577254 - M050261			②			18-0418	
	500 BULLDOG W/SSM		540	8	4	1990-2001	C577254 - M050261			④			18-0418	
	500 BULLDOG W/SSM		540	8	4	1990-2001	C577254 - M050261			⑤			18-0418	

- Ⓚ For engines with aluminum exhaust manifolds
- Ⓚ For engines with cast iron exhaust manifolds
- Ⓚ 3" (76mm) O.D. & 0 degree down angle
- Ⓚ 3" (76mm) O.D. & 15 degree down angle
- Ⓚ 4" (102mm) O.D.
- Ⓚ 2 piece exhaust manifold
- Ⓚ 1 piece exhaust manifold
- Ⓚ Has a rectangular elbow mounting bolt pattern
- Ⓚ Has a square elbow mounting bolt pattern

- Ⓚ In-line applications
- Ⓚ V-drive applications
- Ⓚ Standard rise
- Ⓚ 2" (51mm) rise
- Ⓚ 3" (76mm) rise
- Ⓚ 6" (152mm) rise
- Ⓚ Port
- Ⓚ Starboard
- Ⓚ Engines with risers or closed cooling may require a different gasket than listed

- Ⓚ Exhaust manifold with external water rail
- Ⓚ Exhaust manifold w/o external water rail
- Ⓚ 1 piece exhaust manifold is n/a. Engine must be converted to the 2 piece exhaust system
- ♣ Engines with easy drain system
- ♣ Engines with multi-point drain system
- ♣ Intermediate collector housing



Features...

- Manufactured to meet or exceed OEM specifications.
- High Efficiency Filter
- Field-tested and approved.
- Anti-drainback valves where required.

Part #	O.E. #	Application
18-7824-2*	54111, 14957, 32716, 35-802885Q, 35-866340K01, 35-866340Q03, 35-866340Q02, 35-866340K01, 35-866340Q, 52731A1, 52731, 52022, 32717, 14957	GM Engines ① (Short Filter)
18-7871	35-805809, 35-805809T	D7.3L Diesel
18-7875*	60565, 35-802886Q	Ford Engines (Long Filter)
18-7876-1*	52731, 35-16595T, 35-866340Q03, 35-866340Q02, 32-802885Q, 14957, 54111, 52731A1, 52022, 32717, 32716	GM Engines (Long Filter)
18-7878-1*	803470, 803470Q, 46692, 38463	60 & 80 HP Engines (Renault) (Short Filter)
18-7879-1*	41815, 35-802884Q, 35-883702Q, K	GM V-6 Engines



OIL FILTERS

- ① Do not use on V-6 engines equipped with remote oil filter kit
- * Display Packaged

SEE PAGES 182-184 & 1147-1170 FOR ADDITIONAL INFORMATION

OIL PANS AND GASKET

Part No.	OE	OE No.	Application
18-0612	Mercruiser	809910, 14259	1 piece rear main seal; GM Small Block V8 (Right Handed Dipstick)
18-0613	Mercruiser	93476	2 piece rear main seal; GM Small Block V8 (Right Handed Dipstick)
18-0614	Mercruiser	845668T, 850458, 811549	1 piece rear main seal; GM Big Block V8 (Right Handed Dipstick)
18-0615	Mercruiser	93477T, 93477, 14760, 75639	2 piece rear main seal; GM Big Block V8 (Right Handed Dipstick)
18-0616	Mercruiser	14244T, 14244	1 piece rear main seal; GM V6 (Right Handed Dipstick)

Drain Plug: M12 - 1.75

CYLINDER HEAD ASSEMBLIES

All cylinder heads are new castings and complete assemblies with new- stainless steel valves, hardened steel exhaust seats, valve springs, valve locks, and retainers.
All GM cylinder heads utilize high performance screw-in rocker arm studs in place of factory press in rocker arm studs.



18-4485

CYLINDER HEAD ASSEMBLY

Replaces: 938-883490R1, 938-883490, 938-883490R50, 938-884741R 938-884741R50

Fits: 5.7L V-8 GM (1987-95) with press in rocker arm studs with 12 intake manifold mounting bolts- (4 inside intake manifold bolts at 23 degrees), center mount valve covers



18-4486

CYLINDER HEAD ASSEMBLY

Replaces: 938-883297 1, 938-803860T

Fits: 5.7L V-8 GM Vortec (1996-Up) with press in rocker arm studs with 8 intake manifold mounting bolts, composite valve cover



18-4486HP

CYLINDER HEAD ASSEMBLY

Fits: Vortec GM small block 5.7L high performance

Completely assembled with revised runner and combustion chambers. Add 30hp to stock motor with no additional modifications.

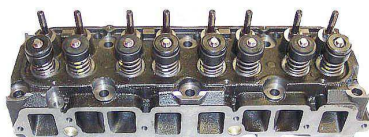

18-4489

CYLINDER HEAD ASSEMBLY

Replaces: 936-5544, 936-810840

1.94/1.60 valves.

Fits: 2.5L/3.0L GM (1968-95) (non MerCruiser LX models) (1968-95)



18-4491

CYLINDER HEAD ASSEMBLY

Replaces: 938-827178

Replaces 4.3L Vortec V-6 (1996-Up) with screw in rocker arm studs (non-adjustable valve train), 8 intake manifold mounting bolts, center mount valve cover. NOTE: not for use with engines using factory roller rocker arms.



18-4501

CYLINDER HEAD

Fits: 5.0L Vortec



18-4501HP

CYLINDER HEAD

Fits: Vortec GM small block 5.0L

Completely assembled with revised runner and combustion chambers. Add 30hp to stock motor with no additional modifications.





18-4492
ROCKER ARM ASSEMBLY
 Replaces: 35329, F3746241, FI1100014, FI1100495
 Fits: MCM/MIE Gm V6 & V8(283, 305 & 350 cid) engines



18-7508
POWER STEERING PUMP
 Replaces: 16792A39, 16792A33



18-8227
POWER STEERING PUMP PULLEY
 Replaces: 73873A1, 73873
 For: Sterndrives with v-belt



18-8297
POWER STEERING PUMP PULLEY
 Replaces: 861578
 For: Sterndrives with serpentine belt



18-1400
HYDRAULIC LIFTER
 Replaces: 17340, 17340T
 GM 4.3L/V-6 Late/5.0L/5.7L



18-1401
HYDRAULIC LIFTER
 Replaces: 56153, F724102
 Ford 302/351
 Ford 5.0L & 5.8L



18-1402
HYDRAULIC LIFTER
 Replaces: 72638, 34282, 35583, 46472, 46744, 49117, F2769931, F5232670, FI1100349, FI1100399, FI1100862, FI1100954, FI1101222
 GM 2.5L/120
 For: Mercruiser 140 (S/N 2508261-6229717), 140/3.0L (S/N 6229718-up), 3.0L/3.0LX (S/N C856559-up)

PISTONS



All pistons are supplied complete with piston rings and wrist pin.

RINGS	
STD	REPLACES
18-3928	39-74381A1, 39-75422
18-3937	39-17464, 39-65153, 39-67123, 39-34988, F328506, F3892364, FI1100386, FI1100692, FI1101321
18-3940	39-67127
18-3942	39-67132, 39-67119, 39-58096, 39-34479
18-3944	39-75609, FI1101057
.020	
18-3939	39-66217, 39-97125, 39-48344, FI1100387, FI1100783, FI1101134
.030	
18-3938	39-17465, 39-67126, 39-48345, FI1100694, FI1101322, F328516

PISTONS	
STD	REPLACES
18-4180	736-2343, 733-66217, 733-2278
18-4181	735-6538
18-4161	733-3819, 733-803850T, 733-4028, 24-38191, FI1100779, FI1100780
18-4109	778-9441A3, 759-80661A7, 759-80661A3, 759-8312A2, 759-831210, 759-661010, 759-592010, 778-9015A2
18-4173	735-6370, 735-9686, 735-808674, 735-850097, 735-808674A1, 735-808661, 735-9703, 735-6370, FI1101184, FI1101318, FI1101334, 833232E
.020	
18-4160	733-3818, 733-38181, FI1100781
18-4189	737-6523, 737-6523, 737-879194035, FI1101101
.030	
18-4134	778-9441A5, 759-80661A8, 759-80661A5, 759-9015A4, 759-8312A6, 759-831212, 759-661012, 759-592012
18-4164	735-6371, 735-9687, 735-850098, 735-9431, 735-9704, FI1101185, FI1101320, FI1101336
18-4178	735-9715, 735-97151, 735-9715T1, FI1101317
18-4191	733-3819, 733-38191, 733-803850T, 733-4028, FI1100779, FI1100780

PISTON/RING APPLICATION

Liter	Model	Note	CID	# Cyl	Stroke	Year	Serial #	Pistons Std.	0.02	0.03	Rings Std.	0.02	0.03	Qty. Eng.
1.6L	100 VASER		98	4	4	2007-2010	W995000 & UP	-	-	-	-	-	-	
2.5L	120		153	4	4	1964-1986	1666601 - B531853	18-4180	-	-	-	-	-	
2.5L	2.5L		153	4	4	1987-1989	B531854 - C853255	18-4180	-	-	-	-	-	
3.0L	140		181	4	4	1968-1986	2508261 - B450800	18-4161	18-4160	18-4191	18-3937	18-3939	18-3938	4
3.0L	140				4		3332138 - 5157668	18-4161	18-4160	18-4191	18-3937	18-3939	18-3938	4
3.0L	140				4		5157669 - 6229717	18-4161	18-4160	18-4191	18-3937	18-3939	18-3938	4
3.0L	140 / 3.0L				4		6229718 - C856558	18-4161	18-4160	18-4191	18-3937	18-3939	18-3938	4
3.0L	3.0L		181	4	4	1987-1989	B450801 - C856558	18-4161	18-4160	-	-	-	-	
3.0L	3.0L		181	4	4	1990-1994	C856559 - F603999	-	-	-	18-3937	18-3939	18-3938	6
3.0L	3.0L		181	4	4	1998-2010	L010042 & UP	-	-	-	-	-	-	
3.0L	3.0L MPI		181	4	4	2008-2010	A072812 & UP	-	-	-	-	-	-	
3.0L	3.0LX		181	4	4	1990-1997	C856559 - K999999	-	-	-	-	-	-	
3.7L	165 / 3.7L		224	4	4	1987-1989	B434941 - C762299	-	-(11)	18-4134	-	-	-	
3.7L	170		224	4	4	1985-1986	6916779 - B434940	18-4109	18-4118	18-4134	18-3928	18-3929	-	4
3.7L	180 / 3.7LX		224	4	4	1987-1989	B436391 - C762299	18-4109	-(11)	18-4134	-	-	-	
3.7L	190 / 3.7L		224	4	4	1985-1986	6916779 - B436390	18-4109	-(11)	18-4134	-	-	-	
3.7L	470		224	4	4	1976-1984	4208730 - 6916779	18-4109	18-4118	18-4134	18-3928	18-3929	-	4
3.7L	485		224	4	4	1980-1982	5685394 - 6218036	18-4109	-(11)	18-4134	-	-	-	
3.7L	488		224	4	4	1983-1984	6170297 - 6916778	18-4109	-(11)	18-4134	-	-	-	
	150				4		1666495 - 2048046	18-4180	18-4183	-	18-3942	-	-	6
4.1L	160		250	6	4	1987-1989	2048022 - 2770031	-	-	-	18-3942	-	-	
4.1L	165		250	6	4	1970-1981	2770032 - 5813433	-	-	-	18-3942	-	-	
4.3L	175 / 4.3L				4		B527955 - & Up	18-4173	18-4188	18-4164	18-3937	18-3939	18-3938	6
3.8L	185	2bbl			4	1983-1984	6330183 - 6919655	-	-	-	18-3944	-	-	
4.3L	175 / 4.3L		262	6	4	1987-1992	B527955 - D714106	-	-	-	-	-	-	
4.3L	185	2bbl	262	6	4	1985-1986	A331455 - B527954	-	-	18-4164	18-3937	18-3939	-	
4.3L	205 / 4.3LX		262	6	4	1985-1986	A331455 - B527954	-	-	18-4164	18-3937	18-3939	18-3938	
4.3L	262 MAG EFI GEN +		262	6	4	1987-1991	B527955 - D714369	18-4173	-	-	-	-	-	
4.3L	262 MAG EFI GEN +		262	6	4	1996-1997	F803800 - K999999	-	-	-	-	-	-	
4.3L	4.3L GEN II		262	6	4	1992-1996	D714107 - F802999	18-4173	18-4188	-	-	-	18-3938	6
4.3L	4.3L GEN +		262	6	4	1998-2010	L010044 & UP	-	-	-	-	-	-	
4.3L	4.3L EFI GEN +		262	6	4	1998-2001	L012009 - M299999	-	-	-	-	-	-	
4.3L	4.3L MPI		262	6	4	2002-2010	M322761 & UP	-	-	-	-	-	-	
4.3L	4.3LH GEN +		262	6	4	1998-2002	L010044 - M614999	-	-	-	-	-	-	
4.3L	4.3LX GEN II		262	6	4	1992-1996	D7141370 - F802999	-	-	18-4164	18-3937	18-3939	18-3938	6
4.3L	4.3LX GEN +		262	6	4	1996-1997	F803000 - K999999	-	-	-	-	-	-	
4.3L	4.3LXH GEN +		262	6	4	1996-1997	F803114 - K999999	-	-	-	-	-	-	
4.9L	215	FORD	302	8	4	1970-1972	2781153 - 3395720	-	-	-	18-3937	18-3939	18-3938	8
4.9L	215	FORD			4	1973-1974	3385721 - 4166999	-	-	-	18-3937	18-3939	18-3938	8
	225	GM			4		1536920 - & Up	-	-	-	18-3937	18-3939	18-3938	8
4.6L	190	GM	283	8	4	1963-1964	1564539 - 1730903	18-4180	18-4183	-	18-3942	-	-	6
5.0L	198 MIE		305	8	4	1977	4776402 - 4931099	-	-	-	-	-	-	
5.0L	200		305	8	4	1985-1987	6899058 - B525981	-	-	-	-	-	-	
5.0L	200 / 5.0L	GM	305	8	4	1987	B525982 - B774444	-	-	18-4178	18-3944	-	-	8
	200	GM			4		6218462 - & Up	-	-	-	18-3944	-	-	8
5.0L	228	GM	305	8	4	1977-1984	4765100 - 6899268	-	-	-	18-3944	-	-	8
5.0L	228 MIE		305	8	4	1977-1980	5170009 - 5907057	-	-	-	-	-	-	
5.0L	230		305	8	4	1985-1987	6899269 - B525981	-	-	-	-	-	-	
5.0L	230		305	8	4	1987-1995	B525982 - B773739	-	-	18-4178	18-3944	-	-	8
5.0L	230 MIE	GM	305	8	4	1981-1987	5907058 - B522505	-	-	-	18-3944	-	-	8
5.0L	230 MIE		305	8	4	1987	B522506 - B788151	-	-	18-4178	18-3944	-	-	8
5.0L	230 GM				8		6218462 - & Up	-	-	-	18-3944	-	-	8
5.0L	5.0L		305	8	4	1988-1995	B774445 - F600999	-	-	-	-	-	-	
5.0L	5.0L GEN +		305	8	4	1998-2010	L015751 & UP	-	-	-	-	-	-	
5.0L	5.0L EFI GEN +		305	8	4	1998-2001	L012052 - M299999	-	-	-	-	-	-	

- (1) Cast Aluminum (Use with GM Engine Code 1XW)
- (2) Cast aluminum (Use with GM Engine Code 4XW)
- (3) Forged Aluminum (Use with GM Engine Code 3UB)
- (4) Cast Aluminum (Use with GM Engine Code 4XX)

- (5) Cast Aluminum (Use with GM Engine Code 2XY)
- (6) Cast Aluminum (Use with GM Engine Code 4XY)
- (7) Flat Head
- (8) Forged Aluminum, Recessed Head

- (9) Starboard
- (10) Port
- (11) .010 (25mm) Oversize
- N.L.A. No longer available from O.E. source

PISTON/RING APPLICATION

Liter	Model	Note	CID	# Cyl	Stroke	Year	Serial #	Pistons Std.	0.02	0.03	Rings Std.	0.02	0.03	Qty. Eng.
5.0L	5.0L MIE		305	8	4	1988	B788152 - C396832	-	-	-	-	-	-	
5.0L	5.0L MPI		305	8	4	2002-2010	M300000 & UP	-	-	-	-	-	-	
5.0L	5.0LX		305	8	4	1988-1995	B773740 - F600999	-	-	-	-	-	-	
5.0L	898 / 198	GM	305	8	4	1977-1984	4762210 - 6899057	18-4181	-	-	18-3944	-	-	8
5.4L	225 MCM / 225 MIE	GM	327	8	4	1963-1969	1539620 - 2694014	-	-	-	-	-	-	
5.4L	250 MCM - 250 MIE	GM	327	8	4	1968-1969	2314301 - 2639854	-	-	-	18-3937	18-3939	18-3938	8
5.7L	250	GM	350	8	4	1977	4768000 - 4908849	18-4173	18-4188	18-4164	18-3937	18-3939	18-3938	8
5.7L	255	GM	350	8	4	1975-1976	4175500 - 4767999	18-4173	18-4188	18-4164	18-3937	18-3939	18-3938	8
5.7L	255 MIE	GM	350	8	4	1975-1980	4175500 - 5907057	18-4173	-	-	-	-	-	8
5.7L	260	GM	350	8	4	1978-1987	4908850 - B773304	18-4173	18-4188	18-4164	18-3937	18-3939	18-3938	8
5.7L	260 MIE	GM	350	8	4	1981-1987	5907058 - B788151	18-4173	18-4188	18-4164	18-3937	18-3939	18-3938	8
5.7L	260 / 5.7L	GM	350	8	4		B525982 - & Up	18-4173	18-4188	18-4164	18-3937	18-3939	18-3938	8
5.7L	270 MCM / 270 MIE		350	8	4	1969-1972	2851074 - 3077735	-	-	-	18-3937	18-3939	18-3938	8
5.7L	280		350	8	4	1975-1976	4176250 - 4770199	-	-	-	-	-	-	8
5.7L	300		350	8	4	1985-1988	6686877 - B430367	-	-	-	18-3937	18-3939	18-3938	8
5.7L	320 EFI		350	8	4	1987-1989	A543604 - C622418	-	-	-	18-3937	18-3939	18-3938	8
5.7L	320 GM EFI BRAVO			8	4		B157603 - & Up	-	-	-	18-3937	18-3939	18-3938	8
	325	GM			4		2278747 - & Up	-	-	-	18-3940	-	-	8
	330	GM			4		4623115 - & Up	-	18-4189	-	18-3940	-	-	8
	330 W/B.W.	GM			4		6083145 - & Up	-	18-4189	-	18-3940	-	-	8
5.7L	350 MAG ALPHA		350	8	4	1986-1997	A635178 - K999999	18-4173	18-4188	18-4164	18-3937	18-3939	18-3938	8
5.7L	350 MAG ALPHA EFI GEN +		350	8	4	1996-1997	F800300 - K999999	-	-	-	-	-	-	8
5.7L	350 MAG BRAVO MPI		350	8	4	1995	F415189 - F601999	18-4173	-	18-4164	-	-	-	8
5.7L	350 MAG BRAVO MPI GEN +		350	8	4	1996-1997	F602000 - K999999	-	-	-	-	-	-	8
5.7L	350 MAG SKI		350	8	4	1994-1996	F215561 - F820706	18-4173	-	18-4164	-	-	-	8
5.7L	350 MAG EFI SKI GEN +		350	8	4	1996-1997	F820707 - K999999	-	-	-	-	-	-	8
5.7L	350 MAG MPI GEN +		350	8	4	1998-2010	L010019 & UP	-	-	-	-	-	-	8
5.7L	350 MAG MPI / 350 MAG HORIZON		350	8	4	2002-2007	M300000 - A299999	-	-	-	-	-	-	8
5.7L	350 MAG MPI / 350 MAG HORIZON / 350 MAG MIE		350	8	4	1998-2007	L304700 - A899999	-	-	-	-	-	-	8
5.7L	350 MAG / 350 MAG MIE / 350 MAG MPI GEN +		350	8	4	1998-2007	L002008 - A089999	-	-	-	-	-	-	8
5.7L	350 MAG MPI SKI		350	8	4	1995-1996	F350583 - F799999	18-4173	-	18-4164	-	-	-	8
5.7L	350 MAG MPI SKI GEN +		350	8	4	1998-2007	L002600 - A089999	-	-	-	-	-	-	8
5.7L	350 MAG SKI		350	8	4	1991-1997	D505450 - K999999	18-4173	18-4188	18-4164	18-3937	18-3939	18-3938	8
5.7L	350	GM	350	8	4		3780450 - & Up	-	-	-	18-3940	-	-	8
5.7L	350 MAG	GM	350	8	4		B525982 - & Up	18-4173	18-4188	18-4164	18-3937	18-3939	18-3938	8
5.7L	5.7L		350	8	4	1988-1995	B773305 - F600999	18-4173	-	18-4164	-	-	-	8
5.7L	5.7L	2bbl	350	8	4	1996-1997	F601000 - K999999	18-4173	-	18-4164	-	-	-	8
5.7L	5.7L GEN +		350	8	4	1998-2010	L010037 & UP	-	-	-	-	-	-	8
5.7L	5.7L EFI		350	8	4	1995-1997	F225560 - K999999	18-4173	-	18-4164	-	-	-	8
5.7L	5.7L EFI GEN +		350	8	4	1998-2001	L010035 - M299999	-	-	-	-	-	-	8
5.7L	5.7L EFI MIE GEN +		350	8	4	1997	K040300 - K999999	-	-	-	-	-	-	8
5.7L	5.7L MIE		350	8	4	1988-1997	B788152 - K999999	18-4173	-	18-4164	-	-	-	8
5.7L	5.7L MIE GEN +		350	8	4	1998-2010	L002003 & UP	-	-	-	-	-	-	8
5.7L	5.7L MPI / 5.7L HORIZON / 5.7L MIE		350	8	4	2008-2010	A090000 & UP	-	-	-	-	-	-	8
5.7L	5.7L MPI / 5.7L MIE		350	8	4	2008-2010	A090000 & UP	-	-	-	-	-	-	8
5.7L	5.7L MPI / 5.7L SKI		350	8	4	2008-2010	A090000 & UP	-	-	-	-	-	-	8
5.7L	5.7L SKI		350	8	4	1985-1997	A338553 - K999999	18-4173	-	18-4164	-	-	-	8
5.7L	5.7L SKI GEN +		350	8	4	1998-2010	L002005 & UP	-	-	-	-	-	-	8
5.7L	5.7LX		350	8	4	1996-1997	F601000 - K999999	18-4173	-	18-4164	-	-	-	8
5.7L	5.7LX BRAVO EFI GEN +		350	8	4	1996-1997	F800300 - K999999	-	-	-	-	-	-	8
5.7L	5.7LX EFI		350	8	4	1996-1997	F752400 - K999999	18-4173	-	18-4164	-	-	-	8
5.7L	BLACK SCORPION SKI GEN +		350	8	4	1998-2007	F800000 - W6988432	-	-	-	-	-	-	8
5.7L	SCORPION 350		350	8	4	2008-2010	W698432 & UP	-	-	-	-	-	-	8
5.8L	233	FORD	351	8	4	1975-1977	4173000 - 4902304	-	-	-	-	-	-	8

- (1) Cast Aluminum (Use with GM Engine Code 1XW)
- (2) Cast aluminum (Use with GM Engine Code 4XW)
- (3) Forged Aluminum (Use with GM Engine Code 3UB)
- (4) Cast Aluminum (Use with GM Engine Code 4XX)

- (5) Cast Aluminum (Use with GM Engine Code 2XY)
- (6) Cast Aluminum (Use with GM Engine Code 4XY)
- (7) Flat Head
- (8) Forged Aluminum, Recessed Head

- (9) Starboard
- (10) Port
- (11) .010 (25mm)Oversize
N.L.A. No longer available from O.E. source

PISTON/RING APPLICATION

Liter	Model	Note	CID	# Cyl	Stroke	Year	Serial #	Pistons Std.	0.02	0.03	Rings Std.	0.02	0.03	Qty. Eng.
5.8L	255	FORD	351	8	4	1973-1974	3258728 - 4175499	-	-	-	-	-	-	8
6.2L	377 MAG		377	8	4	2008-2009	A000000 - A345479	-	-	-	-	-	-	8
6.2L	377 MAG		377	8	4	2009	A345480 - A345492	-	-	-	-	-	-	8
6.2L	377 MAG		377	8	4	2009	A345493 - A345765	-	-	-	-	-	-	8
6.2L	377 MAG		377	8	4	2009	A345766 - A345767	-	-	-	-	-	-	8
6.2L	377 MAG		377	8	4	2009	A345768 - A346789	-	-	-	-	-	-	8
6.2L	377 MAG		377	8	4	2009-2010	A346790 & UP	-	-	-	-	-	-	8
6.2L	377 SCORPION STERNDRIVE		377	8	4	2000-2010	L416146 & UP	-	-	-	-	-	-	8
6.2L	377 SCORPION SKI		377	8	4	1997-1998	K000656 - L600314	-	-	-	-	-	-	8
6.2L	MX 6.2L MPI		377	8	4	2000-2007	L680003 - A299999	-	-	-	-	-	-	8
6.2L	MX 6.2L MPI / MX 6.2L MIE		377	8	4	2002-2009	M300000 - A091825	-	-	-	-	-	-	8
6.2L	MX 6.2L MPI / MX 6.2L MIE		377	8	4	2009-2010	A091826 & UP	-	-	-	-	-	-	8
6.2L	MX 6.2L MPI / MX 6.2L SKI		377	8	4	2002-2007	M317000 - W689999	-	-	-	-	-	-	8
6.2L	MX 6.2L BLACK SCORPION SKI		377	8	4	2001-2007	L670015 - W698432	-	-	-	-	-	-	8
6.2L	SCORPION 377		377	8	4	2008-2009	W698826 & UP	-	-	-	-	-	-	8
6.2L	SCORPION 377 HO / SCORPION 377 EC		377	8	4	2009-2010	A091488 - A092170	-	-	-	-	-	-	8
7.4L	325 MCM / 325 MIE		454	8	4	1969-1972	2278747 - 3780449	-	-	-	-	-	-	8
7.4L	330		454	8	4	1977-1987	4623115 - B816540	-	-	-	-	-	-	8
7.4L	330 MIE		454	8	4	1977-1980	4623115 - 5779913	-	-	-	-	-	-	8
7.4L	340 MIE		454	8	4	1981-1987	5889914 - B788365	-	18-4189	-	18-3940	-	-	8
7.4L	350 MIE		454	8	4	1974-1976	3780450 - 4623109	-	-	-	-	-	-	8
7.4L	370 TRS		454	8	4	1978-1987	4179554 - B714586	-	-	-	18-3940	-	-	8
	390	GM	454	8	4		2781129 - 2825059	-	-	-	18-3940	-	-	8
7.4L	400 TRS		454	8	4	1980-1986	4179554 - B457644	-	-	-	18-3940	-	-	8
7.4L	420		454	8	4	1987-1989	A398941 - B6222418	-	-	-	18-3940	-	-	8
7.4L	425		454	8	4	1990-1992	B622419 - D725499	-	-	-	18-3940	-	-	8
7.4L	425 GEN V		454	8	4	1992-1993	D725500 - D937011	-	-	-	-	-	-	8
7.4L	440 TRS		454	8	4	1983-1986	4179554 - B485220	-	-	-	18-3940	-	-	8
7.4L	450 GEN V		454	8	4	1995-1996	F347100 - F347277	-	-	-	-	-	-	8
7.4L	454 MAG ALPHA		454	8	4	1986-1988	A631894 - B785148	-	18-4189	-	18-3940	-	-	8
7.4L	454 MAG BRAVO		454	8	4	1988-1992	D721206 - D805068	-	-	-	-	-	-	8
7.4L	454 MAG BRAVO GEN V		454	8	4	1992-1996	D805069 - F801699	-	-	-	-	-	-	8
7.4L	454 MAG BRAVO GEN VI		454	8	4	1996-1997	F801700 - K999999	-	-	-	-	-	-	8
7.4L	454 MAG EFI GEN V		454	8	4	1994-1996	F115700 - F802349	-	-	-	-	-	-	8
7.4L	454 MAG EFI SKI GEN V		454	8	4	1995-1996	F215800 - F820099	-	-	-	-	-	-	8
7.4L	454 MAG MPI GEN VI		454	8	4	1996-2001	F802350 - M0224999	-	-	-	-	-	-	8
7.4L	454 MAG MPI / 454 MAG HORIZON / 454 MAG MIE		454	8	4	1998-2001	L002200 - L674000	-	-	-	-	-	-	8
7.4L	454 MAG MPI SKI GEN VI		454	8	4	1996-1997	F820100 - K999999	-	-	-	-	-	-	8
7.4L	454 MAG BRAVO		454	8	4		B840126 - & Up	-	-	-	18-3940	-	-	8
	470		454	8	4		4208730 - & Up	18-4109	18-4118	18-4134	18-3928	18-3929	-	4
	485		454	8	4		5685394 - & Up	18-4109	18-4118	18-4134	18-3928	18-3929	-	4
	488		454	8	4		6170297 - & Up	18-4109	18-4118	18-4134	18-3928	18-3929	-	4
	525 SC		454	8	4	1991-1992	D456000 - D725808	-	-	-	-	-	-	8
7.4L	525 SC GEN V		454	8	4	1992-1996	D763746 - F348963	-	-	-	-	-	-	8
7.4L	525 SC GEN V		454	8	4	1996-1999	F615814 - L415623	-	-	-	-	-	-	8
7.4L	7.4L BRAVO		454	8	4	1988-1991	B771113 - D603117	-	-	-	-	-	-	8
7.4L	7.4L BRAVO I GEN V / 7.4L BRAVO II GEN V		454	8	4	1992-1995	D603118 - F800699	-(1)	-	-	-	-	-	8
7.4L	7.4L BRAVO I GEN V / 7.4L BRAVO II GEN V		454	8	4	1992-1996	D603118 - F800699	-(2)	-	-	-	-	-	8
7.4L	7.4L BRAVO III GEN V		454	8	4	1992-1995	D603118 - F800699	-(3)	-	-	-	-	-	8
7.4L	7.4L BRAVO III GEN V		454	8	4	1992-1996	D603118 - F800699	-(4)	-	-	-	-	-	8
7.4L	7.4L BRAVO GEN VI		454	8	4	1996-1997	F800700 - K999999	-	-	-	-	-	-	8
7.4L	7.4L EFI GEN VI / 7.4L MIE GEN VI / 7.4L GEN VI MIE		454	8	4	1996-1997	F874815 - K999999	-	-	-	-	-	-	8
7.4L	7.4L MIE W/HURTH		454	8	4	1988-1992	B788366 - D715493	-	-	-	-	-	-	8
7.4L	7.4L W/HURTH		454	8	4		C391564 - & Up	-	18-4189	-	18-3940	-	-	8

- (1) Cast Aluminum (Use with GM Engine Code 1XW)
- (2) Cast aluminum (Use with GM Engine Code 4XW)
- (3) Forged Aluminum (Use with GM Engine Code 3UB)
- (4) Cast Aluminum (Use with GM Engine Code 4XX)

- (5) Cast Aluminum (Use with GM Engine Code 2XY)
- (6) Cast Aluminum (Use with GM Engine Code 4XY)
- (7) Flat Head
- (8) Forged Aluminum, Recessed Head

- (9) Starboard
- (10) Port
- (11) .010 (25mm) Oversize
- N.L.A. No longer available from O.E. source

PISTON/RING APPLICATION

Liter	Model	Note	CID	# Cyl	Stroke	Year	Serial #	Pistons Std.	0.02	0.03	Rings Std.	0.02	0.03	Qty. Eng.
7.4L	7.4L MIE GEN V		454	8	4	1992-1995	D715494 - F820141	- (5)	-	-	-	-	-	8
7.4L	7.4L MIE GEN V		454	8	4	1992-1996	D715494 - F820141	- (5)	-	-	-	-	-	8
7.4L	7.4L MIE GEN VI		454	8	4	1996-1997	F820142 - K999999	-	-	-	-	-	-	8
7.4L	7.4L MPI GEN VI		454	8	4	1998-2001	L010003 - M024330	-	-	-	-	-	-	8
7.4L	7.4L MPI GEN V / 7.4L MIE GEN V		454	8	4	1995-1996	F563052 - F820103	-	-	-	-	-	-	8
7.4L	7.4L MPI GEN VI / 7.4L MIE GEN VI / 7.4LH GEN VI		454	8	4	1996-1997	F820104 - K999999	-	-	-	-	-	-	8
7.4L	7.4L MPI L-29 GEN VI / 7.4L MIE L-29 GEN VI		454	8	4	1998-2001	L002006 - M025999	-	-	-	-	-	-	8
7.4L	7.4LX BRAVO GEN VI / 7.4L BRAVO EFI		454	8	4	1996-1997	F802000 - K999999	-	-	-	-	-	-	8
7.4L	7.4LX BRAVO GEN V / 7.4L MPI GEN V		454	8	4	1996	F602010 - F801999	-	-	-	-	-	-	8
7.4L	7.4LX BRAVO GEN VI / 7.4L MPI GEN VI		454	8	4	1996-1997	F802000 - K999999	-	-	-	-	-	-	8
7.9L	390		482	8	4	1969-1970	2781129 - 2825059	-	-	-	-	-	-	8
7.9L	460 TRS		482	8	4	1983-1986	4179554 - 6181046	-	-	-	-	-	-	8
8.1L	496		482	8	4	2001-2010	M025000 & UP	- (9)	-	-	-	-	-	8
8.1L	496		496	8	4	2001-2010	M025000 & UP	- (10)	-	-	-	-	-	8
8.2L	465		502	8	4	1990-1992	C849992 - D725646	-	-	-	-	-	-	8
8.2L	465 GEN V		502	8	4	1992-1994	D725647 - F213244	-	-	-	-	-	-	8
8.2L	500 GEN V		502	8	4	1994-1996	F213293 - F745159	-	-	-	-	-	-	8
8.2L	500 GEN VI		502	8	4	1997-1999	K745195 - L601036	-	-	-	-	-	-	8
8.2L	500 EFI		502	8	4	1999-2005	L001477 - M907127	-	-	-	-	-	-	8
8.2L	502 MAG BRAVO		502	8	4	1990-1992	C878221 - D824588	-	-	-	-	-	-	8
8.2L	502 MAG BRAVO GEN V		502	8	4	1992-1993	D824589 - F114528	-	-	-	-	-	-	8
8.2L	502 MAG EFI		502	8	4	1993-1996	D640650 - F802599	-	-	-	-	-	-	8
8.2L	502 MAG MPI GEN VI		502	8	4	1996-2001	F802600 - M024999	-	-	-	-	-	-	8
8.2L	525 EFI		502	8	4	2003-2010	M900146 & UP	-	-	-	-	-	-	8
8.2L	575 Sci		502	8	4	2001-2005	L306696 - M950526	-	-	-	-	-	-	8
8.2L	600 SC		502	8	4	1991-1992	D456469 - D456768	-	-	-	-	-	-	8
8.2L	600 SC GEN V		502	8	4	1992-1996	D725676 - F877642	-	-	-	-	-	-	8
8.2L	600 SC GEN VI		502	8	4	1997-2000	K000227 - L601186	-	-	-	-	-	-	8
8.2L	8.2L MAG EC		502	8	4	2010	A350340 & UP	-	-	-	-	-	-	8
8.2L	8.2L MIE / 8.2L EC		502	8	4	2010	A350802 & UP	-	-	-	-	-	-	8
8.2L	8.2L MIE W/HURTH		502	8	4	1990-1992	C878221 - D857199	-	-	-	-	-	-	8
8.2L	8.2L MIE GEN V		502	8	4	1993-1995	D857200 - F819619	-	-	-	-	-	-	8
8.2L	8.2L MPI GEN VI / 8.2L MIE GEN VI / 8.2LH GEN VI		502	8	4	1996-2001	F819620 - L674200	-	-	-	-	-	-	8
8.9L	500 BULLDOG		540	8	4	1990-2001	C577254 - M050281	-	-	-	-	-	-	8
8.9L	575		540	8	4	1986-1992	A677429 - D763716	- (7)	-	-	18-3937	18-3939	18-3938	8

- (1) Cast Aluminum (Use with GM Engine Code 1XW)
- (2) Cast aluminum (Use with GM Engine Code 4XW)
- (3) Forged Aluminum (Use with GM Engine Code 3UB)
- (4) Cast Aluminum (Use with GM Engine Code 4XX)
- (5) Cast Aluminum (Use with GM Engine Code 2XY)
- (6) Cast Aluminum (Use with GM Engine Code 4XY)
- (7) Flat Head
- (8) Forged Aluminum, Recessed Head
- (9) Starboard
- (10) Port
- (11) .010 (25mm) Oversize
N.L.A. No longer available from O.E. source



ROD BEARINGS
(Sold individually, 1 per rod)

Part No.	Size	Replaces :
18-1148	Std.	68704A1, 23-853853, 23-853853A1, 23-853853002
18-1308	Std.	23-85701, 23-15961, 23-52221, 23-52270, F3910555, F3916351, F1100305, F1100570
18-1309	0.01	23-85704, 23-52224, 23-52273, 23-1596110, F1100381, F1100573
18-1327	Std.	23-11992, 23-11992001
18-1329	Std.	23-85677, 23-52242, 23-48351
18-1333	0.01	23-85691, 23-69887, 23-49171
18-1334	Std.	23-85726, 23-85726001, 23-49168, 23-69884, F1100980
18-1337	0.01	23-811858, 23-811858001
18-1341	0.02	23-85705, 23-1596120, 23-52225, 23-52274, F1100382

MAIN BEARINGS

Part No.	Per Eng.	Size	Replaces:
18-1131	4	0.010	74313A4
18-1137 ①	1	0.020	15103-A3
18-1300	①	Std.	23-818465, 23-85698, 23-52211, 23-15960, F724073
18-1311	①	Std.	23-801793
18-1316	①	0.010	23-818471, 23-818471001, 23-52264, 23-85718, F3829064, F1100853
18-1317	①	Std.	23-818469, 23-818469001, 23-34464, 23-85669, 23-85715, 23-52261,
18-1320	①	0.010	23-801803

CAM BEARINGS



Part No.	Per Eng.	Replaces:
18-1305	1 ①	23-85684
18-1339	1 ①	23-43293, 23-43293T, F3750884, F1101007
18-1340	5 ①	23-67484

① Complete engine set
② Priced per piece. Add -9 to order priced per package.

BEARING APPLICATION

HP	Liter	Model	Note	CID	# Cyl	Stroke	Year	Serial #	Rod Bearing			Main Bearing			
									Std.	0.01	0.02	Std.	0.01	0.02	Cam Bearing
100		100 VASER		98	4	4	2007-2010	W995000 & UP	-	-	-	-	-	-	-
120		120		153	4	4	1964-1986	1666601 - B531853	18-1329	-	-	-	-	-	-
120	2.5L	120/2.5L		153	4	4	1987-1989	B531854 - C853255	18-1329	18-1330	-	18-1317	18-1316	-	18-1339
140		140		181	4	4	1968-1986	2508261 - B450800	18-1308	18-1309	18-1341	18-1317	18-1316	-	18-1331
140		140		181	4	4		3462608 - 5157668	18-1308	18-1309	18-1341	18-1317	18-1316	-	18-1339
140		140		181	4	4		5157669 - 6229717	18-1308	18-1309	18-1341	18-1317	18-1316	-	18-1339
140	3.0L	140 / 3.0L		181	4	4		6229718 & Up	18-1308	18-1309	18-1341	18-1317	18-1316	-	18-1339
	3.0L	3.0L		181	4	4	1987-1989	B450801 - C856558	18-1308	-	-	-	-	-	-
	3.0L	3.0L		181	4	4	1990-1994	C856559 - F603999	18-1308	18-1309	18-1341	18-1317	18-1316	-	18-1339
	3.0L	3.0L		181	4	4	1998-1999	L010042 - L605541	18-1308	-	-	-	-	-	-
	3.0L	3.0L		181	4	4	2000-2010	L605542 & UP	-	-	-	-	-	-	-
	3.0L	3.0L MPI		181	4	4	2008-2010	A07282 & UP	-	-	-	-	-	-	-
	3.0L	3.0LX		181	4	4	1990-1997	C856559 - K999999	18-1308	-	18-1341	-	-	-	-
		165		224	4	4	1987	B434941 - B774251	-	-	-	-	-	-	-
		170		224	4	4	1985-1986	6916779 - B434940	-	-	-	-	-	-	-
		180		224	4	4	1987	B436391 - B775248	-	-	-	-	-	-	-
		190		224	4	4	1985-1986	6916779 - B436390	-	-	-	-	-	-	-
	3.7L	3.7L		224	4	4	1988-1989	B774252 - C762299	-	-	-	-	-	-	-
	3.7L	3.7LX		224	4	4	1988-1989	B775249 - C762299	-	-	-	-	-	-	-
		470		224	4	4	1976-1984	4208730 - 6916778	-	-	-	-	-	-	-
		485		224	4	4	1980-1982	5685394 - 6218036	-	-	-	-	-	-	-
		488		224	4	4	1983-1984	6170297 - 6916778	-	-	-	-	-	-	-
		140		6	4			1538930 - 1725960	18-1329	18-1330	-	-	-	-	-
		150			4			1666495 - 2048046	18-1329	18-1330	-	-	-	-	-
		160		250	6	4	1967-1969	2048022 - 2770031	18-1329	18-1330	-	-	18-1320	-	-
		165		250	6	4	1970-1981	2770032 - 5813433	18-1329	18-1330	-	-	18-1320	-	-
	4.3L	175 / 4.3L		262	6	4		B527955 & Up	18-1327	18-1337	18-1338	18-1311	-	-	-
		185	4bbl	229	6	4	1983-1984	6330183 - 6919655	-	-	-	-	-	-	-
		175		262	6	4	1987	B527955 - B773242	-	-	-	-	-	-	-
		185	2bbl	262	6	4	1985-1986	A331455 - B527954	-	-	-	-	-	-	-
		205		262	6	4	1985-1986	A331455 - B527954	-	-	-	18-1300	-	-	-
	4.3L	262 MAG / 262 EFI / 262 GEN +		262	6	4	1996-1997	F803800 - K999999	-	-	-	-	-	-	-
	4.3L	4.3L GEN II		262	6	4	1992-1996	D714107 - F802999	18-1327	18-1337	18-1338	18-1311	-	-	-
	4.3L	4.3L GEN +		262	6	4	1998-2010	L010044 & UP	-	-	-	-	-	-	-
	4.3L	4.3L EFI / 4.3L GEN +		262	6	4	1998-2001	L012009 - M299999	-	-	-	-	-	-	-
	4.3L	4.3L MPI		262	6	4	2002-2010	M3000000 & UP	-	-	-	-	-	-	-
	4.3L	4.3LH GEN +		262	6	4	1998-2002	L010044 - M614999	-	-	-	-	-	-	-
	4.3L	4.3LX		262	6	4	1988-1991	B775130 - D714369	-	-	-	-	-	-	-
	4.3L	4.3LX GEN II		262	6	4	1992-1996	D714370 - F802999	-	-	-	-	-	-	-
	4.3L	4.3LX GEN +		262	6	4	1996-1997	F803000 - K999999	-	-	-	-	-	-	-
	4.3L	4.3LXH GEN +		262	6	4	1996-1997	F803114 - K999999	-	-	-	-	-	-	-
		185		262	6	4		A331455 & Up	18-1327	18-1337	18-1338	18-1311	-	-	-
		205		262	6	4		A331455 & Up	18-1327	18-1337	18-1338	18-1311	-	-	-
	4.3L	205 / 4.3L / 4.3LX LX		262	6	4		B527955 & Up	18-1327	18-1337	18-1338	18-1311	-	-	-
		4.3LX GEN II		262	6	4		D714370 & Up	18-1327	18-1337	18-1338	18-1311	-	-	-
		190	GM	283	8	4	1963-1964	1564539 - 1730903	18-1329	18-1330	-	-	-	-	-
		200						2453769 - 2712072	18-1308	18-1309	18-1341	18-1317	18-1316	-	-
		200	GM			4		6218462 & Up	18-1308	18-1309	18-1341	18-1300	-	-	-
	5.0L	500			8	4		B525982 & Up	18-1308	18-1309	18-1341	18-1300	-	-	-
	5.0L	215	FORD	302	8	4		2781153 - 3395720	18-1336	-	-	-	-	-	-
	5.0L	225	FORD	302	8	4	1973-1974	3385721 - 4166999	18-1329	18-1330	-	-	-	-	-
	5.0L	225 S	FORD	302	8	4	1973-1974	3385721 - 4166999	-	-	-	-	-	-	-
	5.0L	225	GM		8	4		1536920 - 2278646	18-1329	18-1330	-	-	-	-	-
	5.0L	225	GM		8	4		2278647 - 2399397	18-1329	18-1330	-	18-1317	18-1316	-	-
	5.0L	225	GM		8	4		2399398 & Up	18-1308	18-1309	18-1341	18-1300	-	-	-
	5.0L	225	GM		8	4		4765100 & Up	18-1308	18-1309	18-1341	18-1300	-	-	-

CHART CONTINUED ON NEXT PAGE

BEARING APPLICATION

HP	Liter	Model	Note	CID	# Cyl	Stroke	Year	Serial #	Rod Bearing			Main Bearing			
									Std.	0.01	0.02	Std.	0.01	0.02	Cam Bearing
	5.0L	888		302	8	4	1971-1977	3108723 - 4887829	-	-	-	-	-	-	-
		190		283	8	4	1963-1964	1564539 - 1730903	18-1329	-	-	-	-	-	-
	5.0L	198 MIE		305	8	4	1977	4776402 - 4931099	18-1308	-	-	-	-	-	-
	5.0L	200		305	8	4	1985-1987	6899058 - B774444	18-1308	-	-	-	-	-	-
	5.0L	228		305	8	4	1977-1984	4765100 - 6899268	18-1308	-	-	-	-	-	-
	5.0L	228 MIE		305	8	4	1977-1980	4765100 - 5907057	18-1308	-	-	-	-	-	-
	5.0L	230		305	8	4	1985-1987	6899269 - B773739	18-1308	-	-	-	-	-	-
	5.0L	230	GM	305	8	4	1981-1987	5907058 - B788151	18-1308	18-1309	18-1341	18-1300	-	-	-
	5.0L	5.0L		305	8	4	1988-1995	B774445 - F600999	18-1308	-	-	-	-	-	-
	5.0L	5.0L GEN +		305	8	4	1998-2010	L015751 & UP	18-1308	-	-	-	-	-	-
	5.0L	5.0L EFI GEN +		305	8	4	1998-2001	L012052 - M299999	18-1308	-	-	-	-	-	-
	5.0L	5.0L MIE		305	8	4	1988	B788152 - C396832	18-1308	-	-	-	-	-	-
	5.0L	5.0L MPI		305	8	4	2002-2010	M3000000 & UP	18-1308	-	-	-	-	-	-
	5.0L	5.0LX		305	8	4	1988-1995	B773740 - F600999	18-1308	-	-	-	-	-	-
	5.0L	230 / 5.0L	GM	305	8	4		B522506 & Up	18-1308	18-1309	18-1341	18-1300	-	-	-
		230	GM		8	4		6218462 & Up	18-1308	18-1309	18-1341	18-1300	-	-	-
	5.0L	230 / 5.0L / 5.0LX	GM	305	8	4		B525982 & Up	18-1308	18-1309	18-1341	18-1300	-	-	-
	5.0L	898		305	8	4	1977-1984	4762210 - 6899057	18-1308	-	-	-	-	-	-
		225	GM	327	8	4	1963-1967	1539620 - 2399397	18-1329	-	-	-	-	-	-
		225	GM	327	8	4	1968-1969	2399398 - 2694014	18-1308	-	-	-	-	-	-
		250		327	8	4	1968-1969	2314301 - 2639854	18-1308	18-1309	18-1341	18-1300	-	-	-
	5.7L	250		350	8	4	1977	4768000 - 4908849	18-1308	18-1309	18-1341	18-1300	-	-	-
	5.7L	255	GM	350	8	4	1975-1976	4175500 - 4767999	18-1308	18-1309	18-1341	18-1300	-	-	-
	5.7L	255 MIE		350	8	4	1975-1980	4175500 - 5907057	18-1308	-	-	-	-	-	-
	5.7L	260	GM	350	8	4	1978-1987	4908850 - B773304	18-1308	18-1309	18-1341	18-1300	-	-	-
	5.7L	260 MIE		350	8	4	1981-1987	5907058 - B788151	18-1308	18-1309	18-1341	-	-	-	-
	5.7L	260 / 5.7L	GM	350	8	4		B525982 & Up	18-1308	18-1309	18-1341	18-1300	-	-	-
	5.7L	260 / 5.7L	GM	350	8	4		B522506 & Up	18-1308	18-1309	18-1341	18-1300	-	-	-
	5.7L	270	GM	350	8	4	1969-1972	2851074 - 3077735	18-1308	18-1309	18-1341	18-1300	-	-	-
	5.7L	280	GM	350	8	4	1975-1976	4176250 - 4770199	18-1308	18-1309	18-1341	18-1300	-	-	-
	5.7L	300	GM	350	8	4	1985-1986	6668677 - B430367	18-1308	18-1309	18-1341	18-1300	-	-	-
	5.7L	320 EFI	GM	350	8	4	1987-1989	A543604 - C622418	18-1308	18-1309	18-1341	18-1300	-	-	-
	5.7L	320 EFI BRAVO	GM	350	8	4		B157603 & Up	18-1308	18-1309	18-1341	18-1300	-	-	-
		325 GM			8	4		2278747 & Up	18-1334	18-1333	18-1332	-	-	-	-
		330 GM			8	4		4623115 & Up	18-1334	18-1333	18-1332	-	-	-	-
		330 W.B.W.	GM		8	4		6083045 & Up	18-1334	18-1333	18-1332	-	-	-	-
	7.4L	340 / 7.4L	GM		8	4		5899914 & Up	18-1334	18-1333	18-1332	-	-	-	-
	5.7L	350 MAG ALPHA		350	8	4	1986-1997	A635178 - K999999	18-1308	18-1309	18-1341	18-1300	-	-	-
	5.7L	350	GM	350	8	4		3780450 & Up	18-1334	18-1333	18-1332	-	-	-	-
	5.7L	350 MAG / 350 ALPHA / 350 EFI / 350 GEN +		350	8	4	1996-1997	F800300 - K999999	18-1308	-	-	-	-	-	-
	5.7L	350 MAG / 350 BRAVO / 350 MPI		350	8	4	1995	F415189 - F601999	18-1308	-	-	-	-	-	-
	5.7L	350 MAG / 350 BRAVO / 350MPI / 350 GEN +		350	8	4	1996-1997	F602000 - K999999	18-1308	-	-	-	-	-	-
	5.7L	350 MAG SKI		350	8	4	1994-1996	F215561 - F820706	18-1308	-	-	-	-	-	-
	5.7L	350 MAG EFI SKI GEN +		350	8	4	1996-1997	F820707 - K999999	18-1308	-	-	-	-	-	-
	5.7L	350 MAG MPI GEN +		350	8	4	1988-2010	L010019 & UP	18-1308	-	-	-	-	-	-
	5.7L	350 MAG MPI / 350 MAG MIE GEN +		350	8	4	1998-2007	L002008 - A089999	18-1308	-	-	-	-	-	-
	5.7L	350MG / 350 MPI / 350 SKI		350	8	4	1995-1996	F350583 - F799999	18-1308	-	-	-	-	-	-
	5.7L	350 MAG / 350 MPI / 350 SKI / 350 GEN +		350	8	4	1998-2007	L002600 - A089999	18-1308	-	-	-	-	-	-
	5.7L	350 MAG SKI		350	8	4	1991-1997	D505450 - K999999	18-1308	-	-	-	-	-	-
	5.7L	5.7L		350	8	4	1988-1997	4908850 - F600999	18-1308	-	-	-	-	-	-
	5.7L	5.7L GEN +		350	8	4	1998-2010	L010037 & UP	18-1308	-	-	-	-	-	-
	5.7L	5.7L EFI		350	8	4	1995-1997	F225560 - K999999	18-1308	-	-	-	-	-	-
	5.7L	5.7L EFI GEN +		350	8	4	1998-2001	L010035 - M299999	18-1308	-	-	-	-	-	-

CHART CONTINUED ON NEXT PAGE

BEARING APPLICATION

HP	Liter	Model	Note	CID	# Cyl	Stroke	Year	Serial #	Rod Bearing			Main Bearing				
									Std.	0.01	0.02	Std.	0.01	0.02	Cam Bearing	
5.7L	5.7L	EFI MIE GEN +		350	8	8	1997	K040300 - K999999	18-1308	-	-	-	-	-	-	-
5.7L	5.7L	MIE		350	8	4	1988-1997	B788152 - K999999	18-1308	-	-	-	-	-	-	-
5.7L	5.7L	MIE GEN +		350	8	4	1998-2010	L002003 & UP	18-1308	-	-	-	-	-	-	-
5.7L	5.7L	MPI / 5.7L MIE		350	8	4	2008-2010	A090000 & UP	18-1308	-	-	-	-	-	-	-
5.7L	5.7L	MPI SKI		350	8	4	2008-2010	A090000 & UP	18-1308	-	-	-	-	-	-	-
5.7L	5.7L	SKI		350	8	4	1985-1987	A338553 - K999999	18-1308	-	-	-	-	-	-	-
5.7L	5.7L	SKI GEN +		350	8	4	1998-2010	L002005 & UP	18-1308	-	-	-	-	-	-	-
5.7L	5.7L	5.7LX		350	8	4	1996-1997	F601000 - F600999	18-1308	-	-	-	-	-	-	-
5.7L	5.7L	5.7LX / 5.7LX BRAVO / 5.7LX EFI / 5.7LX GEN +		350	8	4	1996-1997	F800300 - K999999	18-1308	-	-	-	-	-	-	-
5.7L	5.7L	EFI		350	8	4	1996-1997	F752400 - K999999	18-1308	-	-	-	-	-	-	-
5.7L	5.7L	BLACK SCORPION SKI GEN +		350	8	4	1996-2006	F800000 - W689999	18-1308	-	-	-	-	-	-	-
5.7L	5.7L	BLACK SCORPION SKI GEN +		350	8	4	2003-2007	W690000 - W698432	1	1	-	-	-	-	-	-
5.7L	5.7L	SCORPION 350		350	8	4	2008-2010	W698433 & UP	1	1	-	-	-	-	-	-
	233			351	8	4	1975-1977	4173000 - 4902304	-	-	-	-	-	-	-	-
	255		FORD	351	8	4	1973-1974	3258728 - 4175499	-	-	-	-	-	-	-	-
	TOURNEY SKI				8	4		D505450 & Up	18-1308	18-1309	18-1341	18-1300	-	-	-	-
	370 TRS		GM		8	4		6721528 & Up	18-1334	18-1333	18-1332	-	-	-	-	-
	377 MAG			377	8	4	2008-2010	A3000000 & UP	1	1	-	-	-	-	-	-
	377 SCORPION MCM			377	8	4	1999-2005	L416145 - M907201	1	1	-	-	-	-	-	-
	377 SCORPION SKI GEN +			377	8	4	1997-1998	K000656 - L600314	1	1	-	-	-	-	-	-
6.2L	6.2L	MX 6.2L MPI		377	8	4	2000-2007	L680003 - A299999	1	1	-	-	-	-	-	-
6.2L	6.2L	MX 6.2L MPI / MX 6.2L HORIZON		377	8	4	2002-2007	M3000000 - A299999	1	1	-	-	-	-	-	-
6.2L	6.2L	MX 6.2L MPI / MX 6.2L HORIZON / MX 6.2L MIE		377	8	4	2002-2010	M3000000 & UP	1	1	-	-	-	-	-	-
6.2L	6.2L	MX 6.2L MPI / MX 6.2L MIE		377	8	4	2002-2010	M3000000 & UP	1	1	-	-	-	-	-	-
6.2L	6.2L	MX 6.2L BLACK SCORPION SKI		377	8	4	2002-2007	M300000 - W698432	1	1	-	-	-	-	-	-
6.2L	6.2L	SCORPION 377		377	8	4	2008-2010	W698433 & UP	1	1	-	-	-	-	-	-
7.4L	7.4L	325		454	8	4	1969-1972	2278747 - 3780449	-	-	-	-	-	-	-	-
7.4L	7.4L	330		454	8	4	1977-1987	4623115 - B816540	-	-	-	-	-	-	-	-
7.4L	7.4L	330 MIE		454	8	4	1977-1980	4623115 - 5889913	-	-	-	-	-	-	-	-
7.4L	7.4L	340 MIE W/B-W		454	8	4	1981-1987	5889914 - B788365	-	-	-	-	-	-	-	-
7.4L	7.4L	350 MIE		454	8	4	1974-1976	3780450 - 4623109	-	-	-	-	-	-	-	-
7.4L	7.4L	370 TRS		454	8	4	1978-1987	4179554 - B714586	-	-	-	-	-	-	-	-
	390		GM		8	4		2781129 - 2825059	18-1334	18-1333	18-1332	-	-	-	-	-
7.4L	7.4L	400 TRS		454	8	4	1980-1986	4179554 - B457644	-	-	-	-	-	-	-	-
7.4L	7.4L	420		GM	454	8	4	1987-1989	A398941 - B622418	18-1334	18-1333	18-1332	-	-	-	-
7.4L	7.4L	425		GM	454	8	4	1990-1992	B622419 - D725499	-	-	-	-	-	-	-
7.4L	7.4L	425 GEN V		454	8	4	1992-1993	D725500 - D937011	-	-	-	-	-	-	-	-
7.4L	7.4L	440 TRS		454	8	4	1983-1986	4179554 - B485220	-	-	-	-	-	-	-	-
7.4L	7.4L	450 GEN V		454	8	4	1995-1996	F347100 - F347277	-	-	-	-	-	-	-	-
7.4L	7.4L	454 MAG ALPHA		GM	454	8	4	1986-1988	A631894 - B785148	18-1334	18-1333	18-1332	-	-	-	-
7.4L	7.4L	454 MAG BRAVO		454	8	4	1988-1992	B721206 - D805068	-	-	-	-	-	-	-	-
7.4L	7.4L	454 MAG BRAVO		GM	454	8	4		B840126 & UP	18-1334	18-1333	18-1332	-	-	-	-
7.4L	7.4L	454 MAG BRAVO GEN V		454	8	4	1992-1996	D805069 - M801699	18-1334	18-1333	18-1332	-	-	-	-	-
7.4L	7.4L	454 MAG BRAVO GEN VI		454	8	4	1996-1997	F801700 - K999999	-	-	-	-	-	-	-	-
7.4L	7.4L	454 MAG EFI GEN V		454	8	4	1994-1996	F115700 - F802349	-	-	-	-	-	-	-	-
7.4L	7.4L	454 MAG EFI SKI GEN V		454	8	4	1995-1996	F215800 - F820099	-	-	-	-	-	-	-	-
7.4L	7.4L	454 MAG MPI GEN VI		454	8	4	1996-2001	F802350 - M024999	-	-	-	-	-	-	-	-
7.4L	7.4L	454 MAG MPI / 454 MAG HORIZON / 454 MAG MIE		454	8	4	1998-2001	L002200 - L674000	-	-	-	-	-	-	-	-
7.4L	7.4L	454 MAG MPI / 454 MAG SKI GEN VI		454	8	4	1996-1997	F820100 - K999999	-	-	-	-	-	-	-	-
7.4L	7.4L	454 EFI		454	8	4		F115700 & UP	18-1334	18-1333	18-1332	-	-	-	-	-
	502 MAG		GM		8	4		C878221 & Up	18-1334	18-1333	18-1332	-	-	-	-	-
	502 MAG BRAVO GEN V				8	4		D824589 & Up	18-1334	18-1333	18-1332	-	-	-	-	-
	502 MAG BRAVO GEN V				8	4		D840650 & Up	18-1334	18-1333	18-1332	-	-	-	-	-
	502 EFI				8	4		3108723 & Up	18-1336	-	-	-	-	-	-	-

1 8 Pair Bearing Set

CHART CONTINUED ON NEXT PAGE







BEARING APPLICATION

HP	Liter	Model	Note	CID	# Cyl	Stroke	Year	Serial #	Rod Bearing			Main Bearing			
									Std.	0.01	0.02	Std.	0.01	0.02	Cam Bearing
		525 SC		454	8	4	1991-1992	D456000 - D725808	-	-	-	-	-	-	-
		525 SC GEN V		454	8	4	1992-1996	D763746 - F745215	-	-	-	-	-	-	-
		525 SC GEN V		454	8	4	1996-1999	F745260 - L415623	-	-	-	-	-	-	-
7.4L		7.4L BRAVO		454	8	4	1988-1991	B771113 - D603117	-	-	-	-	-	-	-
7.4L		7.4L BRAVO GEN V		454	8	4	1992-1996	D603118 - F800699	-	-	-	-	-	-	-
7.4L		7.4L BRAVO GEN VI		454	8	4	1996-1997	F800700 - K299999	-	-	-	-	-	-	-
7.4L		7.4L EFI / 7.4L MIE GEN VI		454	8	4	1996-1997	F874815 - K999999	-	-	-	-	-	-	-
7.4L		7.4L MIE		454	8	4	1988-1992	B788366 - D715493	-	-	-	-	-	-	-
7.4L		7.4L MIE GEN V		454	8	4	1992-1996	D715494 - F820141	-	-	-	-	-	-	-
7.4L		7.4L LH / 7.4L MIE GEN VI		454	8	4	1996-1997	F820142 - K999999	-	-	-	-	-	-	-
7.4L		7.4L MPI GEN V		454	8	4	1998-2001	L010003 - M024330	-	-	-	-	-	-	-
7.4L		7.4L MPI GEN V / 7.4L MIE GEN V		454	8	4	1995-1996	F563052 - F820103	-	-	-	-	-	-	-
7.4L		7.4L MPI GEN VI / 7.4L MIE GEN VI		454	8	4	1996-1997	F820104 - K999999	-	-	-	-	-	-	-
7.4L		7.4L MPI GEN VI L29 / 7.4L MIE GEN VI L29		454	8	4	1998-2001	L002006 - M025999	-	-	-	-	-	-	-
7.4L		7.4LX BRAVO TBI GEN VI		454	8	4	1988-2001	F802000 - K999999	-	-	-	-	-	-	-
7.4L		7.4LX BRAVO MPI GEN V		454	8	4	1996	F602010 - F801999	-	-	-	-	-	-	-
7.4L		7.4LX BRAVO MPI GEN VI		454	8	4	1996-1997	F802000 - K999999	-	-	-	-	-	-	-
7.4L		7.4L BRAVO	GM					D603118 & Up	18-1334	18-1333	18-1332	-	-	-	-
7.4L		7.4L BRAVO GEN V						C991564 & Up	18-1334	18-1333	18-1332	-	-	-	-
7.4L		7.4L WHURTH						D715494 & Up	18-1334	18-1333	18-1332	-	-	-	-
7.4L		7.4LHR GEN V						C878221 & Up	18-1334	18-1333	18-1332	-	-	-	-
		390		482	8	4	1969-1970	2781129 - 2825059	-	-	-	-	-	-	-
		460 TRS		482	8	4	1983-1986	4179554 - 6181046	❶	❶	-	-	-	-	-
		496 MAG / 496 HO		496	8	4	2001-2010	M025000 & UP	-	-	-	-	-	-	-
		8.1S MPI / 8.1S MIE / 8.1S HO		496	8	4	2001-2010	M025000 & UP	-	-	-	-	-	-	-
8.2L		465		502	8	4	1990-1992	C849992 - D725646	-	-	-	-	-	-	-
8.2L		465 GEN V		502	8	4	1992-1994	D725647 - F213244	-	-	-	-	-	-	-
8.2L		500 GEN V		502	8	4	1994-1996	F213293 - F745159	-	-	-	-	-	-	-
8.2L		500 GEN VI		502	8	4	1997-1999	K745195 - L601036	-	-	-	-	-	-	-
8.2L		500 EFI		502	8	4	1999-2000	L001477 - L306499	-	-	-	-	-	-	-
8.2L		500 EFI		502	8	4	2000-2005	L306500 - M907127	-	-	-	-	-	-	-
8.2L		502 MAG BRAVO		502	8	4	1990-1992	C876221 - D824588	-	-	-	-	-	-	-
8.2L		502 MAG BRAVO GEN V		502	8	4	1992-1993	D824589 - F114528	-	-	-	-	-	-	-
8.2L		502 MAG EFI		502	8	4	1993-1996	D840650 - F802599	-	-	-	-	-	-	-
8.2L		502 MAG MPI GEN VI		502	8	4	1996-2001	F802600 - M024999	-	-	-	-	-	-	-
8.2L		525 EFI		502	8	4	2003-2007	M900146 - M958499	-	-	-	-	-	-	-
8.2L		525 EFI		502	8	4	2007-2010	M958500 & UP	-	-	-	-	-	-	-
8.2L		575SCi		502	8	4	2000-2005	L306696 - M950526	-	-	-	-	-	-	-
8.2L		600 SC		502	8	4	1991-1992	D456489 - D456768	-	-	-	-	-	-	-
8.2L		600SC GEN V		502	8	4	1992-1996	D725676 - F877642	-	-	-	-	-	-	-
8.2L		600 SC GEN VI		502	8	4	1997-2000	K000227 - L601186	-	-	-	-	-	-	-
8.2L		8.2L MAG		502	8	4	2010	A350340 & UP	-	-	-	-	-	-	-
8.2L		8.2L MIE		502	8	4	2010	A350802 & UP	-	-	-	-	-	-	-
8.2L		8.2L MIE WHURTH		502	8	4	1990-1992	C878221 - D857199	-	-	-	-	-	-	-
8.2L		8.2L WHURTH (IB)		502	8	4		D857200 & Up	18-1334	18-1333	18-1332	-	-	-	-
8.2L		8.2L MIE GEN V		502	8	4		D857200 - F819619	-	-	-	-	-	-	-
8.2L		8.2L MPI GEN VI / 8.2L MIE GEN VI / 8.2LH GEN VI		502	8	4	1996-2001	F819620 - L674200	-	-	-	-	-	-	-
		500 BULLDOG		540	8	4	1990-1996	C577254 - F745405	❶	❶	-	-	-	-	-
		500 BULLDOG		540	8	4	1997-2001	K000248 - M050281	❶	❶	-	-	-	-	-
		575		540	8	4	1986-1992	A677429 - D763716	❶	❶	-	-	-	-	-
		800 SC GEN V		540	8	4	1993-1998	D763836 & UP	❶	-	-	-	-	-	-
		888	FORD		8	4		4762210 & Up	18-1308	18-1309	18-1341	18-1300	-	-	-
		898 / 198	GM					A338553 & Up	18-1308	18-1309	18-1341	18-1300	-	-	-

❶ 8 Pair Bearing Set

MERCURUISER 3.7L BEARING APPLICATION

Model	Serial #	Rod Bearings			Main Bearings			Main (Thrust Bearings)		
		Std.	.010	.020	Std.	.010	.020	Std.	.010	.020
165\3.7 (4cyl)	6916779 & Up	18-1148	-	-	-	-	-	18-1149	-	-
170 (4cyl)	6916779 & Up	18-1148	-	-	-	-	-	18-1149	-	-
180\3.7L (4cyl)	6916779 & Up	18-1148	-	-	-	-	-	18-1149	-	-
190 (4cyl)	6916779 & Up	18-1148	-	-	-	-	-	18-1149	-	-
470	4208730 & Up	18-1148	-	-	-	-	-	18-1149	-	-
485	5685394 & Up	18-1148	-	-	-	-	-	18-1149	-	-
488	6170297 & Up	18-1148	-	-	-	-	-	18-1149	-	-

 <p>18-0518 VALVE STEM SEAL Replaces: 26-34217, 26-72564, 26-58094, 26-75413, 26-75624</p>	 <p>18-4023 VALVE STEM SEAL Replaces: 26-75413, 26-75624, 26-72564, 26-58094 For: 165, 170, 180, 190 4 cyl. (224 CID) SN 6916779 & later</p>	 <p>18-4022 VALVE STEM SEAL Replaces: 26-75988, 26-75982, 26-67863, 26-49131, F3866612, F1100968, F1101117 For: 330 (SN 4623115 & later), 340 (IB) (SN 5889914 & later), 454 Mag (SN A631894 & later)</p>	 <p>18-4024 18-4024-9² VALVE STEM SEAL Replaces: 26-97664, 26-976641 26-8M0050563, F11101200</p>
 <p>ONE PIECE REAR MAIN SEALS 18-1234 Replaces: 24-811554, 24-17057A1, 24-801879, 24-801879T For: 7.4L, GL, GI, GSI: 8.2L, GL 18-0519 Replaces: 26-14240, F11101300 4.3L/3.0L/5.0L 5.7L 18-0864 Replaces: 26-90925, 27-67389</p>	 <p>TWO PIECE REAR MAIN SEALS 18-0528 Replaces: 26-56868 18-1211 Replaces: 26-58203, 26-49947, 26-814622, F1110026, F1110027, F1110041</p>		 <p>TIMING COVER SEALS 18-1213 Replaces: 26-97335, 26-11973, 26-42750, 26-54799 18-1230 Replaces: 26-56866 18-1233 Replaces: 26-8219471, 26-821947, 26-49154, F11100986 18-0578 Replaces: 26-67388</p>

MERCURUISER SEAL APPLICATION

Model	Serial No.	Rear Main Crankshaft Seal	Timing Cover Seal
120/2.5L	1666601 & UP	—	18-1213
120/2.5L	2786857 & UP	18-1211	18-1213
140/3.0L & LX	2508261 & UP	—	18-1213
140/3.0L & LX	6229718 & UP	18-1211	18-1213
150/160/165/200 (I/L-6)	1666495 & UP	—	18-1213
150/160/165/200 (I/L-6)	2770032 & UP	18-1211	18-1213
175/185/205/262/4.3L (V-6)	6330183 & UP	18-1211	18-1213
200/228/225/230/250/255/260/270/280/300/320/5.0L/5.7L/898 (V-8)	2453769 & UP	18-1211 ¹	18-1213
215	2781153 & UP	18-0528	—
224I/L4	ALL	18-0864	18-0578
225 FORD	3885721 & UP	18-0528	—
5.0L/5.7L, 4.3L, 3.0L Std. Rotation	"All" one piece seal	18-0519	18-1213
340 (7.4L)	4623115 & UP	—	18-1233
370 TRS	5889914 & UP	—	18-1233
400 TRS	4179554 & UP	—	18-1233
420	A398941 & UP	—	18-1233
440 TRS	4179554 & UP	—	18-1233
454 MAGNUM	A631894 & UP	—	18-1233
460 TRS	4179554 & UP	—	18-1233
7.4L/8.2L/454/502 Std. Rotation	"All" one piece seal	18-1234	18-1233
7.4 BRAVO	B771113 & UP	—	18-1233
888 (188)	3108723 & UP	18-0528	—

¹ Lrg. Journal Crankshaft GM Engines ² Priced per Package

SIERRA OFFERS MORE!



PARTS THAT MOVE YOU:

Sierra offers an extensive selection of over 600 Rotating Electrical products, all backed by an industry leading warranty.

Protect your customer and your reputation. Use only a certified marine product from Sierra.

- **Alternators**
- **Solenoids**
- **Starters**
- **Rectifiers**
- **Trim Motors**
- **Accessories**

The Very Best Parts of Boating

www.sierramarine.com

Sierra
Marine Engine and Drive Parts

MANIFOLD & EXHAUST MANIFOLD GASKET SETS



18-0403

INTAKE GASKET KIT

Replaces: 27-805722A1, 27-812712, 27-61782, 27-52571
 For: MCM 370, 400, 325, 454, 502 Mag, 7.4L Bravo II & MIE 8.2L1978-1997



18-0404

INTAKE GASKET KIT

Replaces: 27-805403A1
 For: MCM/MIE 454 Mag MPI, 7.4L/LX MPI & 8.2L MPI 1993-UP



18-0603

EXHAUST MANIFOLD GASKET SET

For: Ford 302/351 CID Engines
 For use with **18-1998-1**

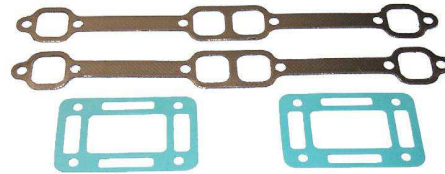

18-0604

EXHAUST MANIFOLD GASKET SET

For: GM 305/350 CID Engines
 For use with **18-1997-1**



18-4347-1

EXHAUST MANIFOLD GASKET SET

For: GM 175, 185, 205 (229 & 262 CID)

— CONTAINS —

Part #	Description	O.E. #	Qty.
18-0897	Exhaust Elbow Mounting Gasket	27-41813-1	2
18-2909	Exhaust Manifold to Cyl. Head Gasket	27-99757	2



18-4348

EXHAUST MANIFOLD GASKET SET

For: GM 454, 525 (7.4L & 8.2L)

— CONTAINS —

Part #	Description	O.E. #	Qty.
18-0418	Manifold to Cylinder Head Gasket	27-46820	2
18-0897	Exhaust Elbow Mounting Gasket	27-41813-1	2

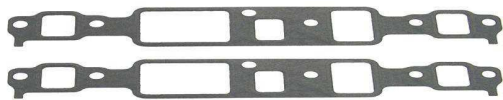

18-4408

INTAKE MANIFOLD GASKET SET

Replaces: 27-11977, 27-11987
 For: GM 262 CID Engines 175, 185 and 205 HP



18-4349

EXHAUST MANIFOLD GASKET SET

For: GM 200, 228, 230, 260, 898 (5.0 & 5.7L)

— CONTAINS —

Part #	Description	O.E. #	Qty.
18-2949	Exhaust Manifold Gasket	27-33395	2
18-0897	Exhaust Elbow Mounting Gasket	27-41813-1	2

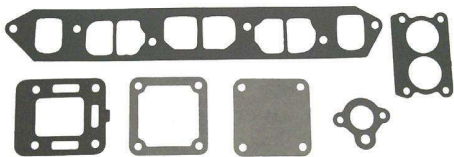

18-4367

EXHAUST MANIFOLD GASKET SET

Replaces: 27-99777A1
 For: GM 153 & 181 (2.5 & 3.0L) CID Eng's; 120 & 140 HP S/N 6229718 & UP
 (With Siamese Port Cylinder Heads)

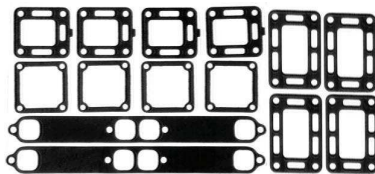

18-4394

EXHAUST MANIFOLD GASKET SET

Replaces: 27-33395A2, 27-33395A1

For: GM 350 (5.7L) CID Eng; 250 HP S/N 4768000-4908849 255 HP S/N 5195909 & UP

— CONTAINS —

Part #	Description	O.E. #	Qty.
18-2832-1	Manifold End Cap Gasket	27-48043	4
18-2833	Exhaust Elbow Gasket	27-99777-2	4
18-2949	Exhaust Manifold Gasket	27-33395	2
18-0885-1	Exhaust Elbow Gasket	27-48042	4

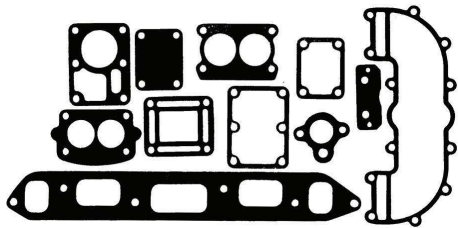

18-4395
EXHAUST MANIFOLD GASKET SET
Replaces: 27-35898A4, 27-35898A3, 27-35898A2
For: GM 153 (2.5L) CID Eng;
 120 HP S/N 2046625-6229717

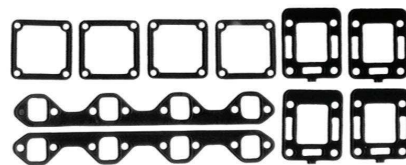

18-4399
EXHAUST MANIFOLD GASKET SET
Replaces: 27-54566A1
For: Ford 302/351 (5.0L & 5.8L) CID Eng; All 888 (188 HP)
 & 233 HP, 255 HP • S/N 3258728-4175498

— CONTAINS —

Part #	Description	O.E. #	Qty.
18-0183-1	Exhaust Mounting Gasket	27-46820	2
18-2832-1	Manifold End Cap Gasket	27-48043-1	4
18-2833	Exhaust Elbow to Gasket	27-99777-2	4

18-4396
EXHAUST MANIFOLD GASKET SET

Replaces: 27-46401A1
For: 250 (4.1L) CID Eng; 165 HP S/N 2770032 & UP

— CONTAINS —

Part #	Description	O.E. #	Qty.
18-2830-1	Intake Exhaust Gasket	27-46401	1
18-2831	Thermostat Gasket	27-47590-1	1
18-2832-1	Manifold End Cap Gasket	27-48083-1	2
18-2833	Exhaust Elbow Gasket	27-99777-2	1
18-0353	Carb. Mounting Gasket	27-58764	1
18-0356	Carb. Mounting Gasket	27-64692	1
18-0928-1	Exhaust End Cap Gasket	27-73814	1

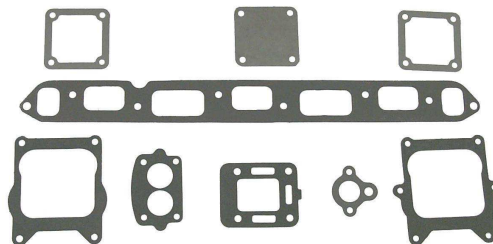

18-4397
EXHAUST MANIFOLD GASKET SET
Replaces: 27-46820A1
For: GM 454 (7.4L) CID Eng; All 325, 350, 400 HP Jet Drives 330 HP S/N 6083144 & BELOW

— CONTAINS —

Part #	Description	O.E. #	Qty.
18-0418	Exhaust Mounting Gasket	27-46820	2
18-0885-1	Exhaust Elbow Mounting Gasket	27-48042	4
18-2832-1	Manifold End Cap Gasket	27-48043-1	4

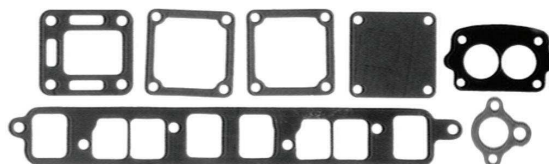

18-4398
EXHAUST MANIFOLD GASKET SET
Replaces: 27-53354A1
For: GM 181 (3.0L) CID Eng; 140 HP S/N 3332137-6229717
 (Without Siamese Port Cylinder)

CYLINDER HEAD AND INTAKE MANIFOLD GASKET SETS

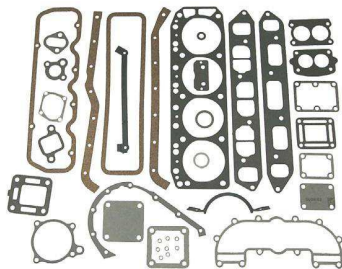

18-4383
For: GM 153 (2.5L) CID Eng;
 S/N 2324347 & UP Includes 18-3880 Head Gasket

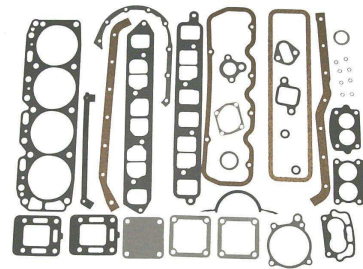

18-4384
For: GM 181 (3.0L) CID Eng;
 S/N 2508261-6229717 (Except 3.0LX)

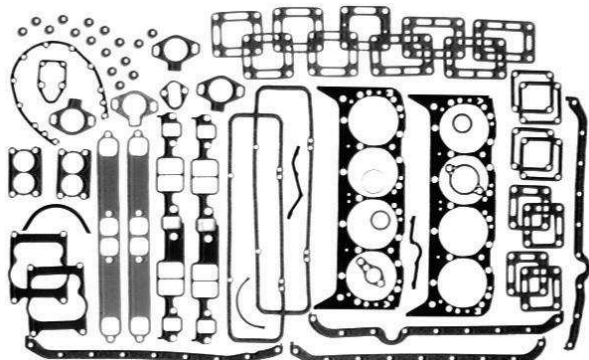

18-4386
For: GM 305 & 350 (5.0L & 5.7L) CID Eng; With Heads (1987 & Earlier)

— CONTAINS —

Part #	Description	O.E. #	Qty.
18-0976	Timing Chain Cover Gasket	27-14250	1
18-0868	Intake Manifold Gasket	27-17145	1
18-2949	Exhaust Manifold Gasket	27-33395	2
18-0897	Exhaust Elbow Mounting Gasket	27-41813	2
18-0885-1	Exhaust Elbow Mounting Gasket	27-48042	4
18-2917	Lower Thermostat Housing Gasket	27-53045-1	1
18-0153	Port Dip Gasket	27-85817A1	1
18-2848	Quadrajet Base Gasket	27-58457-2	2
18-2849-1	Exhaust Elbow To Manifold Gasket	27-8105-1, 27-818832	4
18-3876	Head Gasket	27-75611	2
18-2554	Thermostat Gasket	27-41812	1
18-2832-1	Manifold End Cap Gasket	27-48043-1	4
18-2553	Thermostat Gasket	27-47510	1
18-2833	Exhaust Elbow To Manifold Gasket	27-99777-2	4
18-2844	Thermostat Cover Gasket	27-48818-1	1
18-0889	Fuel Pump Housing Gasket	27-34213	1
18-0891	Water Pump Mounting Gasket	27-34897	1
18-0905	Oil Pan Drain Plug Gasket	27-49955	1
18-0876	Water Pump Mounting Gasket	27-34898	1
18-0994	Carb. Mounting Gasket	27-70143-1	2
18-0518	Seal	26-34217	16
18-2845	Valve Cover Gasket	121-122	2

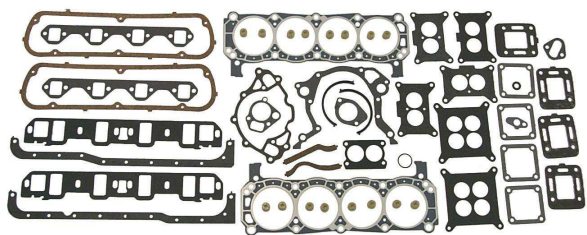

18-4385

For: Ford 302 (5.0L) CID Eng; 215, 225 & 888 (188 HP)
Includes **18-3883** Head Gasket

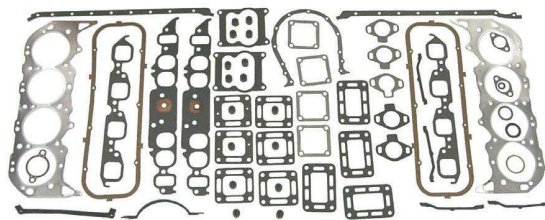

18-4387

Replaces: 27-801853
For: GM 454 (7.4L) CID Eng; Production Models
Oval Port
Includes **18-3877** Head Gasket

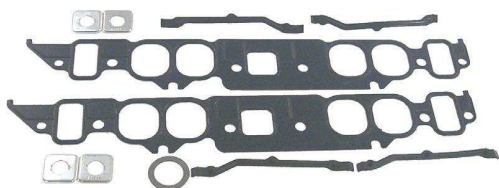

18-0465

INTAKE MANIFOLD GASKET SET

Replaces: 27-65184, 27-8M0050224
For: GM 454 CID Engines, 325, 330, 340, 350 HP
and 454 Magnums, 7.4L

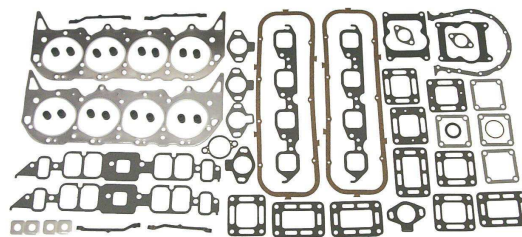

18-4365

INTAKE MANIFOLD GASKET SET

Replaces: 27-801855
For: GM 454 (7.4L) CID Eng; Production Models
Rectangular Port
Includes **18-3877** Head Gasket

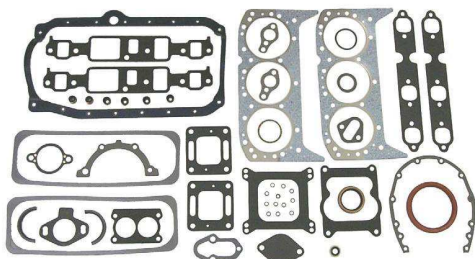

18-4388

INTAKE MANIFOLD GASKET SET

Replaces: 27-11977A88, A92
For: GM 262 CID Eng; 175, 185 & 205 HP, 4.3L
Includes **18-3879** Head Gasket

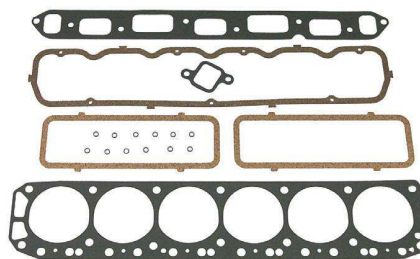

18-4389

INTAKE MANIFOLD GASKET SET

Replaces: 27-47453A1
For: All GM 165 HP (S/N 270032 & UP) & Inline 6 cyl.
250 CID

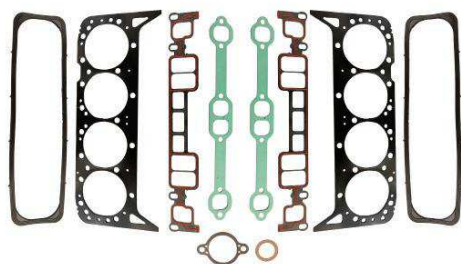

18-1254

**VORTEC
HEAD GASKET SET**

Replaces: 27-75611A03
For: Small Block GM V8 engines with Vortech heads

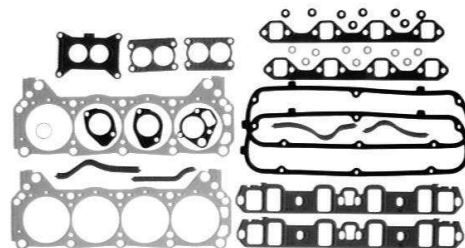

18-4391

INTAKE MANIFOLD GASKET SET

Replaces: 27-64763A2
For: Ford 351 CID Eng; 233 HP S/N 4173000-4500860, 5.8L
Includes **18-3883** Head Gasket

18-4392

INTAKE MANIFOLD GASKET SET

Replaces: 27-75611A2, 27-75611A1
For: GM 305 & 350 CID Eng, 898 (198 HP) 200, 228,
230/260 (Inboard) 230, 250, 255, 260, 280 & 5.7L Ski

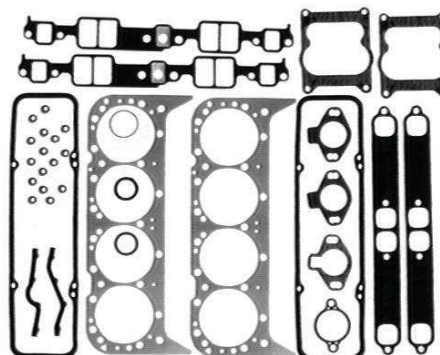

— CONTAINS —

Part #	Description	O.E. #	Qty.
18-0868	Intake Manifold Gasket	27-17145	1
18-2949	Exhaust Manifold Gasket	27-33395	2
18-2848	Quadrajel Base Gasket	27-52457-2	2
18-3876	Head Gasket	27-75611	2
18-2553	Thermostat Gasket	27-47510	1
18-2844	Thermostat Cover Gasket	27-48818-1	1
18-2554	Thermostat Gasket	27-41812	2
18-2917	Lower Thermostat		
	Housing Gasket	27-53045-1	1
18-2845	Valve Cover Gasket	27-11999	2
18-0518	Seal	26-34217	16

FOR MODULAR GASKET SETS SEE PAGES 653-660

OVERHAUL GASKET SETS
(Sets do not include Front and Rear Crankshaft Seals)

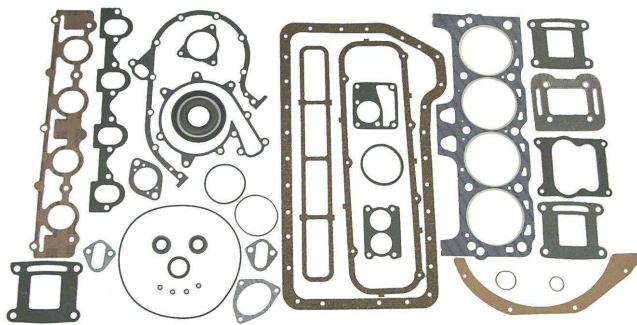

18-4381

Replaces: 27-43186A1, 27-89656A1, 27-41636A1
For: 224 (3.7L) CID Eng; 165, 170, 180, 190 HP
S/N 6916779 & UP

— CONTAINS —			
Part #	Description	O.E. #	Qty.
18-0175	O-Ring	25-26543	4
18-0860	O-Ring	25-62700	1
18-0864	Seal	26-90925	1
18-0881-1	Exhaust Elbow Mounting Gasket	27-18272	1
18-0992	Exhaust Manifold Mounting Gasket	27-68715	1
18-0994	Carburetor Mounting Gasket	27-70143-1	1
18-0158	Intake Manifold Gasket	27-70905	1
18-0111	Exhaust Elbow Mounting Gasket	27-89657	2
18-0160	Lower Exhaust to Intake Manifold Gasket	27-94136	1
18-0113-1	Exhaust Elbow Mounting Gasket	27-97542	1
18-2843	Thermostat Cover Gasket	27-74830	1
18-2848	QuadraJet Base Gasket	27-52457-2	1
18-3878	Head Gasket	27-13709T	1
18-7121	O-Ring	25-35027	1
18-0874	Distributor Gasket	27-34486	1
18-0185	Seal	27-91892	1
18-2555	Thermostat Gasket	27-89656-1	1
18-0889	Fuel Pump Mounting Gasket	27-34213	1
18-4366	Oil Pan Gasket Set	27-72479A5	1
18-0387	Flywheel Cover Gasket	27-94976	1
18-0172	Oil Seal	26-97530	2

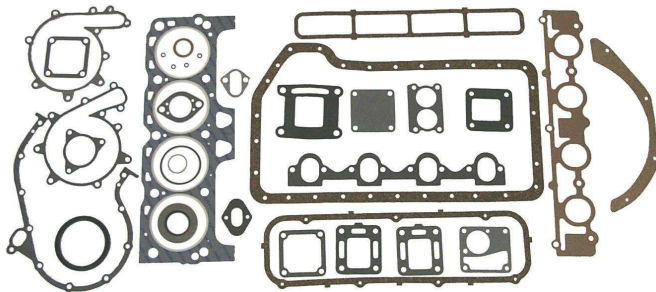

18-4382

Replaces: 27-74830A3, 27-74830A1, 27-74264A1
For: 224 (3.7L) CID Eng; 470 S/N 4208730 & UP

— CONTAINS —			
Part #	Description	O.E. #	Qty.
18-0864	Seal	26-90925	1
18-0956-1	Exhaust Manifold Mounting Gasket	27-68715	1
18-0158	Intake Manifold Gasket	27-70905	1
18-0950	Impeller Cover Gasket	27-88046	1
18-0954	Exhaust Mounting Gasket	27-92720	1
18-0113-1	Exhaust Elbow Mounting Gasket	27-97542	1
18-2832-1	Manifold End Cap Gasket	27-48043-1	2
18-2833	Exhaust Elbow To Manifold Gasket	27-99777-2	2
18-2843	Thermostat Cover Gasket	27-74830	1
18-3878	Head Gasket	27-13709T	1
18-0175	O-Ring	25-26543	4
18-0889	Fuel Pump Mounting Gasket	27-34213	1
18-7121	O-Ring	25-35029	1
18-0874	Distributor Gasket	27-34486-3	1
18-0928-1	Manifold End Cap Gasket	27-73814	1
18-0994	Carb. Mounting Gasket	27-70143-1	1
18-2555	Thermostat Cover Gasket	27-89656-1	1
18-4366	Oil Pan Gasket Set	27-72479A5	1
18-0387	Flywheel Cover Gasket	27-94976	1

MISCELLANEOUS GASKET SETS



18-0153

OIL PAN GASKET SET

Replaces: 27-85817A1, FI5110037, FI5110032, 27-72627
For: Mercruiser GM 350 CID (5.7L)



18-1239

OIL PAN GASKET

Replaces: 27-810846T, 27-810846
For: Mercruiser 3.0L GM 181



18-0348

OIL PAN GASKET SET

Replaces: 27-52550, 27-49107, FI1100229, FI5000229, FI5000245
For: Mercruiser GM 454/502 CID Eng; (7.4L and 8.2L)



18-1237

OIL PAN GASKET

Replaces: 27-138651, 27-13865, FI1101281
For: Mercruiser GM 5.7L



18-0466

OIL PAN GASKET SET

Replaces: 27-14901A1, 27-14901, 27-52144
For: Mercruiser GM 153/181 (2.5L & 3.0L)

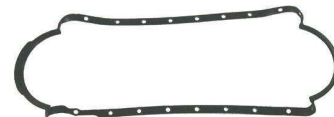

18-1232

OIL PAN GASKET

Replaces: 27-811566, 27-845628
For: GM Big Block



18-1231

INTAKE GASKET

Replaces: 27-8181881, 27-818188
For: Rectangular port high performance big block Chevy



18-0405

OIL PAN GASKET

Replaces: 27-883964, 27-14247, 27-883964T
For: Mercruiser GM 262 CID Eng. (4.3L)



18-1238

INTAKE GASKET SET

Replaces: 27-824326
For: Mercruiser 4.3L/LX models, pre SN F802999



18-61513

OIL PAN GASKET

Replaces: 27-14247T1, 27-142471
Fits: Mercruiser MCM 262 Mag & 4.3L/LX/LH/LHX Gen+ (1996 & Up); All GM V6 (1996 & Up)



18-0407

OIL PAN GASKET SET

Replaces: 27-64798, 27-56870A1
For: Mercruiser: 215, 225, 888



18-0410

INTAKE MANIFOLD GASKET SET

Replaces: 27-75648
For: Ford 5.0L/302, 5.8L/351 CID Engine; (233HP) S/N 3108723 & UP



18-0411

OIL PAN GASKET SET

Replaces: 27-90458A1, 27-90458, FI5000178, FI5000183
For: Mercruiser GM 350 CID (5.7L) Starboard Dipstick



18-0611

OIL PAN GASKET SET

Replaces: 27-75483
For: Mercruiser Ford 351 CID Eng.



18-0868

INTAKE MANIFOLD GASKET SET

Replaces: 27-17145, 27-72637, FI5000263, FI5000232, FI1101296
For: Mercruiser 305, 350

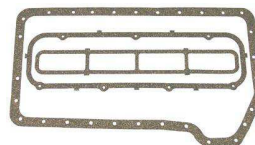

18-4366

OIL PAN GASKET SET

Replaces: 27-72479A5, 27-72479T, 27-72479
For: Mercruiser 224 CID (3.7L)

18-4375

TIMING CHAIN GASKET SET

Replaces: 27-34213A2, 27-34213A1
For: Mercruiser GM 153 & 181 CID Eng's: 110, 120, 130, 140, 150, 160 & 165 HP; 2.5L & 3.0L

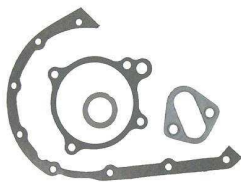

— CONTAINS —

Part #	Description	O.E. #	Qty.
18-0889	Fuel Pump Mounting Gasket	27-34213	1
18-0887	Timing Cover Gasket	27-49953	1
18-0948	Distributor Gasket	27-87707	1
18-0327	Water Pump Gasket	27-33956	1

18-4377

TIMING CHAIN GASKET SET

Replaces: 27-42457A1
For: GM 262 CID Eng; 175, 185 & 205 HP

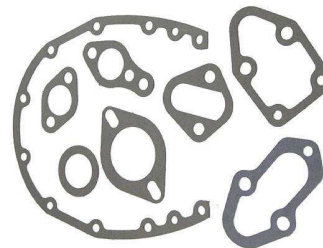

18-4378

TIMING CHAIN GASKET SET

Replaces: 27-54529A1
For: GM 454 CID Eng. 325, 330, 340 & 350 Inboards & 300TRS



— CONTAINS —

Part #	Description	O.E. #	Qty.
18-0889	Fuel Pump Mounting Gasket	27-34213	1
18-0903	Water Pump Gasket	27-49110	2
18-0980	Timing Chain Gasket	27-54529	1

18-4380

TIMING CHAIN GASKET SET

Replaces: 27-68714A6, 27-68714A7, 27-68714, 27-72098
For: Mercruiser 224 CID Eng. 165, 170, 180, 190, 470, 485 & 488 HP

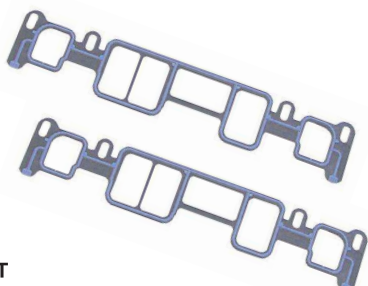

18-0487

INTAKE GASKET SET

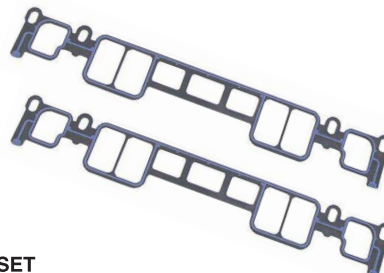

Replaces: 27-8243261, 27-824326002
Fits: MCM 262 Mag & 4.3L/LX/LH/LHX Gen II (1996-up)



18-0488

INTAKE GASKET SET

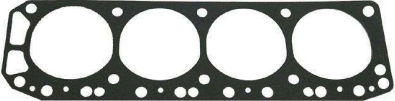
Replaces: 27-807473A1
Fits: MCM 350 Mag, 5.0L & 5.7L/LX Gen II (1996-up)

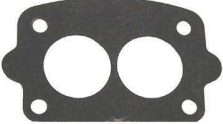
 <p>18-2946 HEAD GASKET Replaces: 27-52364, 27-81084, FI5000204 For: GM 181 (3.0L) CID Eng.</p>	 <p>18-3874 HEAD GASKET Replaces: 27-811546, 27-879150139 For: (8.2L) 502 CID</p>	 <p>18-3876 HEAD GASKET Replaces: 27-75611, 27-75611001, 27-48330, 27-34278 For: GM 305 (5.0L)/350 (5.7L) CID Eng.</p>	
 <p>18-3877 HEAD GASKET Replaces: 27-13218, 27-13687, 27-19315, 27-49104, 27-61224, 27-97529, 27-8M0049045 For: GM 454 (7.4L) CID Eng., Mark IV (pre-1992)</p>	 <p>18-3878 HEAD GASKET Replaces: 27-13709, 27-13709T, 27-74264, 27-79986, 27-92166, 27-921661 For: Mercruiser 224 (3.7L) CID Eng. Model 470</p>	 <p>18-3879 HEAD GASKET Replaces: 27-11986, 27-816460, 27-879150140, 27-42744 For: GM 262 (4.3L) CID Eng.</p>	
 <p>18-3880 HEAD GASKET Replaces: 27-34273, 27-342731 For: GM 153 (2.5L)</p>	 <p>18-3881 HEAD GASKET Replaces: 27-47453, 27-72622, 27-39164, 27-34274 For: GM 250 (4.1L) CID (6 cyl) Eng.</p>	 <p>18-3883 HEAD GASKET Replaces: 27-75647, 27-75646, 27-64763, 27-56110 For: Ford 302 (5.0L) 351 (5.8L) CID Eng.</p>	
 <p>18-3887 HEAD GASKET Replaces: 27-850470, 27-879150141, 27-811547 For: (7.4L) 454 CID GEN V and VI (1992-up)</p>	 <p>18-0353 CARB MOUNTING GASKET Replaces: 27-58764</p>	 <p>18-0354 CARB MOUNTING GASKET Replaces: 27-60715</p>	 <p>18-0685 VALVE COVER GASKET Replaces: 27-73666 224 CID (3.7L)</p>
 <p>18-0356 CARB MOUNTING GASKET (For Rochester) Replaces: 27-64692, 27-32910</p>	 <p>18-0357 CARB MOUNTING GASKET Replaces: 27-65577, 27-56884</p>	<p>PKG. OF 2</p>  <p>18-0876 18-0876-9^① FUEL PUMP GASKET For GM 4.3L, 5.0L & 5.7L Replaces: 27-34898, FI5005756</p>	<p>PKG. OF 2</p>  <p>18-0889 18-0889-9^① FUEL PUMP GASKET For GM 4.3L, 5.0L & 5.7L Replaces: 27-34213, 27-56883, FI5000074</p>
<p>SEE PAGES 201-202 FOR OUR COMPLETE LINE OF GASKET SEALANTS</p>			

① Priced per Package



18-0360
CARB MOUNTING GASKET
 Replaces: 27-70142



18-0462
CARB MOUNTING GASKET
 Replaces: 27-48399

Model	Year	S/N
250	1968-69	2314301-2639854
270	1969-72	2851074-3385720
325	1969-70	2278747-3042730
390	1969-70	2781129-3042731



18-0463
CARB MOUNTING GASKET
 (For Weber)
 Replaces: 27-814210



18-0467
CARB MOUNTING GASKET
 (For Weber)
 Replaces: 27-41610, 27-49814

PKG. OF 2



18-0994
18-0994-9①
CARB MOUNTING GASKET
 Replaces: 27-701431, 27-8079821, 27-807982, 27-70143, 27-807982B, 27-70143B1

PKG. OF 2



18-2848
18-2848-9①
CARB BASE GASKET
 Replaces: 27-524572, 18-52457, 18-524571

PKG. OF 2



18-0874
18-0874-9①
DISTRIBUTOR GASKET
 For GM V6 & V8
 Replaces: 27-344863, 27-344861, 27-34486, 27-52184, 27-34891, F15000162, F3932344
 For: 2.6L (1989), 3.5L (1989), 4.3L (1987-93), 5.0L (1987-88), 5.7L (1987-92), 7.4L (1988-93), 8.2L (1992-93)

PKG. OF 2



18-0948
18-0948-9①
DISTRIBUTOR GASKET
 Replaces: 27-87707 4 Cyl.



18-0422
DISTRIBUTOR CAP GASKET
 Replaces: 391-5076 V8



18-0740-1
THROTTLE BODY GASKET
 Replaces: 27-805396

PKG. OF 2



18-2552
18-2552-9①
THERMOSTAT GASKET
 Replaces: 27-331792, 27-331791

PKG. OF 2



18-0667
18-0667-9①
CONNECTOR COVER GASKET
 Replaces: 27-995061, 27-99506

PKG. OF 2



18-2553
18-2553-9①
THERMOSTAT GASKET
 Replaces: 27-47510, 27-47510Q GM V-6, V-8

PKG. OF 2



18-2554
18-2554-9①
THERMOSTAT GASKET
 Replaces: 27-41812, 27-90556, 27-41812Q V-6 & V-8

PKG. OF 2



18-2555
18-2555-9①
THERMOSTAT GASKET
 Replaces: 27-896561, 27-89656 4 Cyl.

PKG. OF 2



18-2831
18-2831-9①
THERMOSTAT GASKET
 Replaces: 27-475901, 27-47590 4 & 6 Cyl.

PKG. OF 2



18-2834
18-2834-9①
THERMOSTAT GASKET
 Replaces: 27-60208 Ford V-8

PKG. OF 2



18-2843
18-2843-9①
THERMOSTAT GASKET
 Replaces: 27-74830 470

PKG. OF 2



18-2844
18-2844-9①
THERMOSTAT GASKET
 Replaces: 27-48818, 27-488181, 27-48818Q1 V-8











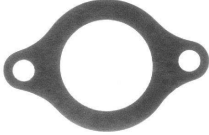





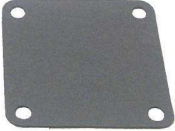

PKG. OF 2

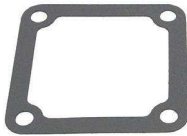

18-2917
18-2917-9①
THERMOSTAT GASKET
 Replaces: 27-53045, 27-530451, 27-33179, F10077105, F11101276, F11101291, F15000096



















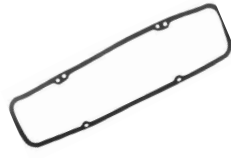

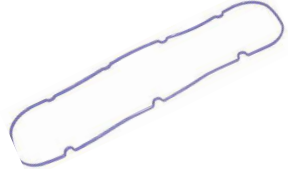
SEE PAGES 201-202 FOR OUR COMPLETE LINE OF GASKET SEALANTS

① Priced per Package

<p>PKG. OF 2</p>  <p>18-0398 18-0398-9① THERMOSTAT GASKET Replaces: 27-8M2021920, 27-33918</p>	 <p>18-0111 EXHAUST ELBOW GASKET Replaces: 27-89657</p>	 <p>18-0113-1 EXHAUST ELBOW GASKET Replaces: 27-97542, 27-856705</p>	<p>PKG. OF 2</p>  <p>18-0672 18-0672-9① EXHAUST ELBOW GASKET Replaces: 27-860231, 27-8637251</p>
 <p>18-0365 HEAT EXCHANGER END GASKET 2 3/4" dia. Replaces: 27-75450 224 CID</p>	 <p>18-0389 HEAT EXCHANGER END GASKET 3 15/16" dia. Replaces: 27-99960</p>	 <p>18-0881-1 EXHAUST ELBOW GASKET Replaces: 27-18272</p>	<p>PKG. OF 2</p>  <p>18-0885-1 18-0885-9① EXHAUST ELBOW GASKET Replaces: 27-48042</p>
 <p>18-0897 EXHAUST ELBOW GASKET Replaces: 27-41813</p>	<p>PKG. OF 2</p>  <p>18-0928-1 18-0928-9① MANIFOLD END CAP GASKET Replaces: 27-73814, 27-738141, 27-807218</p>	 <p>18-0954 EXHAUST ELBOW GASKET Replaces: 27-92720</p>	<p>PKG. OF 2</p>  <p>18-2819-1 18-2819-9① EXHAUST ELBOW GASKET Replaces: 27-39915</p>
<p>PKG. OF 2</p>  <p>18-2832-1 18-2832-1-9① MANIFOLD END CAP GASKET Replaces: 27-480431, 27-48043</p>	<p>PKG. OF 2</p>  <p>18-2833 18-2833-9① EXHAUST ELBOW GASKET Replaces: 27-997772, 27-997771, 27-99777, 27-52076</p>	<p>PKG. OF 2</p>  <p>18-2849-1 18-2849-9-1① EXHAUST ELBOW GASKET Replaces: 27-87105, 27-871051, 27-860232, 27-818832, 27-863726</p>	<p>PKG. OF 2</p>  <p>18-1210-1 END CAP GASKET Replaces: 27-39923</p>
 <p>18-0158 INTAKE MANIFOLD GASKET Replaces: 27-70905 For: 3.7L</p>	 <p>18-0183-1 EXHAUST MANIFOLD GASKET Replaces: 27-73866, 27-54566</p>	 <p>18-0418 EXHAUST MANIFOLD GASKET Replaces: 27-46820</p>	 <p>18-2830-1 EXHAUST MANIFOLD GASKET Inline 6 cyl. Replaces: 879036, 27-46401, 27-52584, 27-33121</p>



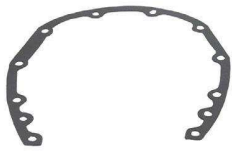











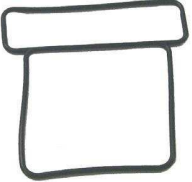

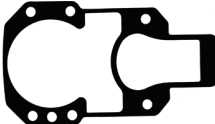
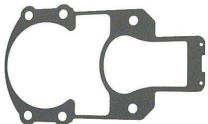

SEE PAGES 201-202 FOR OUR COMPLETE LINE OF GASKET SEALANTS

① Priced per Package

 <p>18-0680 EXHAUST MANIFOLD GASKET Replaces: 27-815528</p>	 <p>18-2896-1 EXHAUST MANIFOLD GASKET Replaces: 27-52546, 27-32816</p>	<p>PKG. OF 2</p>  <p>18-2909 18-2909-9① EXHAUST MANIFOLD GASKET Replaces: 27-99757</p>	 <p>18-2949 EXHAUST MANIFOLD GASKET Replaces: 27-33395 GM 5.0L & 5.7L</p>	 <p>18-2912-1 EXHAUST MANIFOLD GASKET Replaces: 27-53354</p>																									
 <p>18-0956-1 EXHAUST MANIFOLD GASKET Replaces: 27-68715</p>	<p>PKG. OF 2</p>  <p>18-1204-1 18-1204-1-9① EXHAUST MANIFOLD GASKET Replaces: 27-96429</p>	 <p>18-61319 VALVE COVER GASKET Replaces: 27-827154 Fits: Mercruiser MCM 262 Mag & 4.3L/LX/LH/LHX Gen+ w/plastic valve cover(1996 & Up); All GM V6 (1996 & Up)</p>	 <p>18-0664 VALVE COVER GASKET Replaces: 27-17467, F11101287 For: GM 305/350, 5.0 & 5.7L</p>	 <p>18-2845 VALVE COVER GASKET Replaces: 27-11999, 27-34043, 27-52202, F11101236, F15000161 V-8 GM 305/350 CID, 5.0 & 5.7L</p>																									
 <p>18-25001 VALVE COVER GASKET Replaces: 27-14765, F3860315, F11110294, F11110958 Fits: GM 454, 7.4L</p>	 <p>18-25002 VALVE COVER GASKET Replaces: 27-811588 Fits: GM 454, 502, (1992-UP) Recessed Grooved Valve Cover</p>	 <p>18-0311 VALVE COVER GASKET Replaces: 27-11988 For: 4.3 Litre 262 CID</p>	 <p>18-0346 VALVE COVER GASKET Replaces: 27-49936, 27-34042 For: GM 250 CID (4.1L), 160/165/200 (6 cyl.)</p>																										
 <p>18-0347 VALVE COVER GASKET Replaces: 27-52145, 27-806452, 27-34041 For: GM 153 & 181 CID (2.5L & 3.0L)</p>	<p>PKG.. OF 2</p>  <p>18-0464 18-0464-9① VALVE COVER GASKET Replaces: 27-49121, 27-91831 For: GM 454/502 CID (7.4L & 8.2L)</p> <table border="1"> <thead> <tr> <th>Model</th> <th>Year</th> <th>S/N</th> </tr> </thead> <tbody> <tr> <td>330</td> <td>1977-81</td> <td>4623115-6083144</td> </tr> <tr> <td>7.4 Bravo</td> <td>1988-91</td> <td>B771113-D603117</td> </tr> <tr> <td>454 Mag</td> <td>1986-92</td> <td>A631894-D805068</td> </tr> <tr> <td>370 TRS</td> <td>1978-87</td> <td>4179554-B714586</td> </tr> <tr> <td>400 TRS</td> <td>1980-86</td> <td>4179554-B457644</td> </tr> <tr> <td>400 TRS</td> <td>1983-86</td> <td>4179554-B485220</td> </tr> <tr> <td>460 TRS</td> <td>1983-86</td> <td>4179554-6181046</td> </tr> <tr> <td>502 Mag Bravo</td> <td>1990-92</td> <td>C878221-D824588</td> </tr> </tbody> </table>	Model	Year	S/N	330	1977-81	4623115-6083144	7.4 Bravo	1988-91	B771113-D603117	454 Mag	1986-92	A631894-D805068	370 TRS	1978-87	4179554-B714586	400 TRS	1980-86	4179554-B457644	400 TRS	1983-86	4179554-B485220	460 TRS	1983-86	4179554-6181046	502 Mag Bravo	1990-92	C878221-D824588	 <p>18-0352 VALVE COVER GASKET Replaces: 27-56173 For: Ford 302/351 CID (5.0L & 5.8L)</p>
Model	Year	S/N																											
330	1977-81	4623115-6083144																											
7.4 Bravo	1988-91	B771113-D603117																											
454 Mag	1986-92	A631894-D805068																											
370 TRS	1978-87	4179554-B714586																											
400 TRS	1980-86	4179554-B457644																											
400 TRS	1983-86	4179554-B485220																											
460 TRS	1983-86	4179554-6181046																											
502 Mag Bravo	1990-92	C878221-D824588																											
 <p>18-0468 TIMING COVER GASKET Replaces: 27-811572 GM 4.3L, 5.0L & 5.7L</p>	<p>PKG.. OF 2</p>  <p>18-0887 18-0887-9① TIMING COVER GASKET Replaces: 27-49953, 27-34216, F15000201 4 & 6 Cyl.</p>	<p>PKG.. OF 2</p>  <p>18-0976 18-0976-9① TIMING CHAIN COVER GASKET Replaces: 27-14250, 27-34895, F11101297</p>	 <p>18-0980 TIMING COVER GASKET Replaces: 27-54529, 27-49109, 110990, 1100990 GM 7.4L</p>																										

SEE PAGES 201-202 FOR OUR COMPLETE LINE OF GASKET SEALANTS

① Priced per Package

<p>PKG.. OF 2</p>  <p>18-0328 18-0328-9① PUSH ROD/LIFTER COVER GASKET Replaces: 27-34208 153 & 181 CID, 120/140 (4 Cyl.)</p>	 <p>18-0329 PUSH ROD/LIFTER COVER GASKET Replaces: 27-34209 For: 140/150/160/165 (6 cyl.)</p>	 <p>18-2815 PUSH ROD COVER GASKET Replaces: 27-814703, FI5000119, FI5000199 For: 3.0L</p>	<p>PKG. OF 2</p>  <p>18-0185 18-0185-9① REMOTE OIL SEAL Replaces: 27-91892</p>
 <p>18-1240 OUTDRIVE SEAL For Bravo Replaces: 12708</p>	<p>PKG. OF 5</p>  <p>18-2516 18-2516-9① BRAVO OUTDRIVE SEAL Replaces: 16755, 16755A1, 16755Q1</p>	<p>PKG. OF 2</p>  <p>18-2556 18-2556-9① DRIVE SHAFT HOUSING TO BELL HOUSING GASKET Replaces: 27-35996, A1</p>	 <p>18-2743 OUTDRIVE HOUSING GASKET Replaces: 27-94996, 27-949962, 27-94996A1, 27-94996A2, 27-94996Q2, 27-94996A3, 27-94996A20, 27-64818A2</p>
<p>PKG. OF 5</p>  <p>18-2820 18-2820-9① OUTDRIVE GASKET Replaces: 27-64818, Q4, 27-64818A20, 27-64818A4, 27-64818A1, 27-45821</p>	<p>PKG. OF 5</p>  <p>18-2840 18-2840-9① BELL HOUSING GASKET Replaces: 27-35982</p>	<p>PKG. OF 2</p>  <p>18-2847 18-2847-9① OUTDRIVE GASKET Replaces: 27-54014, 27-54014A1, 27-54014Q1, 27-54014T1 For: E, H, TR, TRS</p>	 <p>18-0386 WATER PUMP BODY GASKET Replaces: 27-94914, 27-72780</p>
<p>PKG. OF 2</p>  <p>18-0894 18-0894-9① WATER POCKET COVER GASKET Replaces: 27-55810, 27-55810 -1</p>	 <p>18-0916 WATER PUMP GASKET Replaces: 27-8052151, 27-805215, 27-94915, 27-72779</p>	<p>PKG. OF 2</p>  <p>18-0903 18-0903-9① WATER PUMP GASKET Replaces: 27-49110, FI1101000 454 CID</p>	 <p>18-0147 WATER PUMP GASKET For Ford V-8 Replaces: 27-56880</p>
 <p>18-0327 WATER PUMP GASKET Replaces: 27-33956, FI5000200, FI5000219 4 & 6 Cyl.</p>	<p>PKG. OF 2</p>  <p>18-0891 18-0891-9① WATER PUMP MOUNTING GASKET Replaces: 27-34897, 27-34896, FI5000077, FI5000078 For: GM 4.3L, 5.0L & 5.8L</p>	<p>PKG. OF 2</p>  <p>18-0893 18-0893-9① WATER PUMP BACK-IN PLATE GASKET Replaces: 27-35380 GM 4.3L, 5.0L & 5.7L</p>	<p>PKG. OF 2</p>  <p>18-2564 18-2564-9① IMPELLER GASKET Alpha I - Generation 2 Replaces: 27-430331</p>











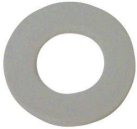







SEE PAGES 201-202 FOR OUR COMPLETE LINE OF GASKET SEALANTS

① Priced per Package

 <p>18-0950 IMPELLER HOUSING GASKET Replaces: 27-88046 224 CID</p>	<p>PKG. OF 2</p>  <p>18-2565 18-2565-9① IMPELLER GASKET Alpha I - Generation 2 Replaces: 27-430472</p>	<p>PKG. OF 2</p>  <p>18-2566 18-2566-9① IMPELLER GASKET Alpha I - Generation 2 Replaces: 27-817277</p>	<p>PKG. OF 2</p>  <p>18-2823 18-2823-9① LOWER WATER PUMP GASKET Replaces: 27-32769, 27-19553</p>
<p>PKG. OF 2</p>  <p>18-2824 18-2824-9① UPPER WATER PUMP GASKET Replaces: 27-32770, 27-19551</p>	<p>PKG. OF 2</p>  <p>18-2825 18-2825-9① WATER PUMP BASE GASKET Replaces: 27-32771</p>	<p>PKG. OF 2</p>  <p>18-2826 18-2826-9① WATER PUMP BASE GASKET Replaces: 27-856101, 27-856704, 27-85610</p>	<p>PKG. OF 2</p>  <p>18-2914 18-2914-9① WATER PUMP GASKET Replaces: 27-856081, 27-85608, 27-32433, 27-30603, 27-8M0090319</p>
<p>PKG. OF 2</p>  <p>18-2915 18-2915-9① WATER PUMP GASKET Replaces: 27-856091, 27-858524, 27-85609, 27-32434, 27-30604</p>	<p>PKG. OF 2</p>  <p>18-2919 18-2919-9① WATER PUMP GASKET Replaces: 27-426311, 27-42631</p>	<p>PKG. OF 2</p>  <p>18-0342 POWER TRIM HOSE CONNECTOR PLATE GASKET Replaces: 27-476441, 27-47644</p>	<p>PKG. OF 2</p>  <p>18-0388 POWER TRIM HOSE CONNECTOR GASKET Replaces: 27-988231, 27-98823</p>
<p>PKG. OF 2</p>  <p>18-0322 18-0322-9① REAR SEAL GASKET Replaces: 27-14241, 27-881715, F11101656 GM 5.0L & 5.7L</p>	<p>PKG. OF 2</p>  <p>18-0898 OIL PUMP MOUNTING GASKET Replaces: 27-56859 For: Ford Engines</p>	<p>PKG. OF 2</p>  <p>18-3289 DOUBLE LIP SEAL Replaces: 26-864319 For: Gen II Upper Housing</p>	<p>PKG. OF 2</p>  <p>18-2094 OIL SEAL Replaces: 26-36143, 26-88416 Fits: 120/140(1978-82), 165 (1978-81), 260 (1978-82), 470 (1978-82), 485 (1980-82), 898/228 (1978-82), Alpha I/Gen II (1991 & Up), Blackhawk (1994-95), Bravo I/II/III (1988-98), R/MR/Alpha One Sterndrive and Transom (1983-90)</p>
<p>PKG. OF 2</p>  <p>18-2944 18-2944-9① SEAL RING GASKET (Quad Ring) Replaces: 26-45577, 26-455771</p>	<p>PKG. OF 2</p>  <p>18-2945 18-2945-9① 18-29451-9① (PKG. OF 50) DRAIN SCREW GASKET Replaces: 12-20260, 12-19183, 12-191832, 12-191833, F50556, F8077, F8186 Used in most lower units and sea water pumps</p>	<p>PKG. OF 5</p>  <p>18-2948 18-2948-9① RUBBER WASHER Replaces: 12-492211, 12-49221, 12-23245</p>	<p>PKG. OF 5</p>  <p>18-2349 SHIFT SHAFT SLEEVE Replaces: 23-67370 For: Ratios 1.47, 1.62, 1.81 & 1.94. For: Gen II (1998 & up), (0L100040 & up) 1/4" Thick</p>

SEE PAGES 201-202 FOR OUR COMPLETE LINE OF GASKET SEALANTS

① Priced per Package

<p>PKG. OF 2</p>  <p>18-0905 18-0905-9① OIL PAN DRAIN PLUG GASKET Replaces: 27-49955, 27-34502, 27-60721, 27-8M0077608</p>	<p>PKG. OF 2</p>  <p>18-4267 18-4267-9① SHIFT SHAFT WASHER Replaces: 12-29395, 12-8M0042641</p>	<p>PKG. OF 3</p>  <p>18-0681 18-0681-9① WASHER Replaces: 12-32834, 12-8M2001219, 12-93416, 12-934161</p>	<p>PKG. OF 5</p>  <p>18-0203 18-0203-9① BELL HOUSING WASHER Replaces: 12-35935 All Mercruiser Stern drives 1963-1998</p>																		
<p>PKG. OF 5</p>  <p>18-2316 18-2316-9① SHIFT SHAFT WASHER Replaces: 12-77674, 12-25410 Used over 18-2349 sleeve For: Ratios 1.47, 1.62, 1.81 & 1.94 For: Gen II (1998 & up), (0L100040 & up) 1/8" Thick</p>	 <p>18-0318 WASHER Replaces: 12-815472</p>	<p>PKG. OF 2</p>  <p>18-4270 18-4270-9① WASHER Replaces: 12-36001</p>	<p>PKG. OF 5</p>  <p>18-2340 18-2340-9① SHIFT SHAFT WASHER Replaces: 12-31266 For: #1R/MR (1/16" Thick)</p>																		
<p>PKG. OF 2</p>  <p>18-2343 18-2343-9① PINION NUT WASHER Replaces: 12-92721 For: MR/Alpha/Gen II</p>	<p style="text-align: center;">SCREWS</p>  <table border="1"> <thead> <tr> <th>Part No.</th> <th>Description</th> <th>O.E. #</th> </tr> </thead> <tbody> <tr> <td>18-2361</td> <td>(PKG. OF 2)</td> <td>10-805763, 10-853163</td> </tr> <tr> <td>18-2361-9①</td> <td>Lower Unit Mounting Screw</td> <td>10-30206</td> </tr> <tr> <td>18-3197</td> <td>Water Pick-Up Insert Screw</td> <td>10-76156, 10-67373</td> </tr> <tr> <td>18-3230</td> <td>Gear Housing to Drive Shaft Housing Screw</td> <td>10-816601</td> </tr> <tr> <td>18-3231</td> <td>Upper Drive Shaft Top Cover Screw</td> <td>10-98794</td> </tr> </tbody> </table>		Part No.	Description	O.E. #	18-2361	(PKG. OF 2)	10-805763, 10-853163	18-2361-9 ①	Lower Unit Mounting Screw	10-30206	18-3197	Water Pick-Up Insert Screw	10-76156, 10-67373	18-3230	Gear Housing to Drive Shaft Housing Screw	10-816601	18-3231	Upper Drive Shaft Top Cover Screw	10-98794	<p>PKG. OF 5</p>  <p>18-3721 18-3721-9① NUT Replaces: 11-13439-1, 11-859116 For: MR/Alpha</p>
Part No.	Description	O.E. #																			
18-2361	(PKG. OF 2)	10-805763, 10-853163																			
18-2361-9 ①	Lower Unit Mounting Screw	10-30206																			
18-3197	Water Pick-Up Insert Screw	10-76156, 10-67373																			
18-3230	Gear Housing to Drive Shaft Housing Screw	10-816601																			
18-3231	Upper Drive Shaft Top Cover Screw	10-98794																			
 <p>18-3236 HOUSING ALIGNMENT BUSHING Replaces: 23-32632 For: #1R/MR/Alpha</p>	 <p>18-4272 WELCH PLUG O.D. 0.870" Replaces: 19-32652</p>	 <p>18-4273 WELCH PLUG O.D. 1.250" Replaces: 19-42682</p>	 <p>18-2140 ENGINE MOUNT BOLT KIT For: Mercruiser I</p>																		
 <p>18-2141 ENGINE MOUNT BOLT KIT Replaces: 10-97934A1 For: R/MR/Alpha I/ Gen II/Bravo</p>	 <p>18-3728 LOCK NUT Replaces: 11-99298, 11-863332</p>	 <p>18-3729 MOTOR MOUNT BOLT 1/2" - 20 x 5 3/8" Replaces: 10-97934, 10-36289</p>	 <p>18-2193 REAR ENGINE MOUNT Replaces: 33149, 99297A1, 99297A2 For: 120/140 HP S/N 6229717 & UP; All 224 CID Blocks; All 898, 200, 228, 230, 260, 300 & 320 HP; All 350-454 Magnums</p>																		

① Priced per Package

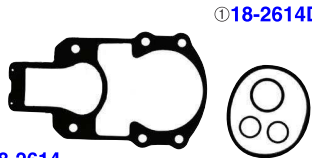

① 18-2614D



**18-2614
OUTDRIVE GASKET SET**

1967-1982
Replaces: 27-64818A1, 27-64818T4,
27-64818Q4, 27-64818A20, 27-64818A4, 27-
64818, 27-45821

—CONTAINS—

Part #	Description	O.E. #	Qty.
18-2820	Drive Shaft Housing to Bell Housing Gasket	27-64818	1
18-2840	Bell Housing Gasket	27-35982	1
18-7153	O-Ring	25-25439	2
18-7170	O-Ring	25-33504	1

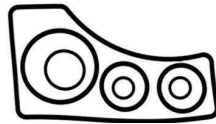

**18-2615
OUTDRIVE GASKET SET**

(Bravo Unit)
Replaces: 16755, 16755A1, 16755Q1, 16755T1
For: All Bravo

—CONTAINS—

Part #	Description	O.E. #	Qty.
18-2516	Seal	16755	1
18-7198	O-Ring	25-45710	1
18-7153	O-Ring	25-25439	2
18-7168	O-Ring	25-48171	2
18-7105	O-Ring	25-62705	1
18-7117	O-Ring	25-35027	1

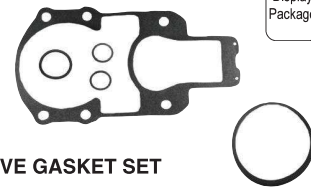

**18-2617
OUTDRIVE GASKET SET**

Old Style
Replaces: 27-35996, 27-35996A1
For: IA/IB/IC and EZ Shift (1964-1966)

—CONTAINS—

Part #	Description	O.E. #
18-2556	Drive Shaft Housing to Bell Housing Gasket	27-35996
18-2840	Bell Housing Gasket	27-35982
18-7153	O-Ring	25-25439
18-7170	O-Ring	25-33504

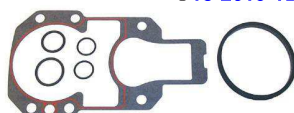

① 18-2619-1D



**18-2619-1
OUTDRIVE GASKET SET**

Replaces: 27-64818A3, 27-94996Q2, 27-94996T2, 27-94996,
27-94996A1, 27-94996A2, 27-94996A20, 27-64818A2, 27-64818A3
For: R, MR, Alpha I, Alpha Gen II (1983-Newer)

—CONTAINS—

Part #	Description	O.E. #
18-2743	Drive Shaft Housing to Bell Housing Gasket	27-94996-2
18-2840	Bell Housing Gasket	27-35982
18-7153	O-Ring	25-25439
18-7170	O-Ring	25-33504
18-7117	O-Ring	25-35027



**18-2620
OUTDRIVE GASKET SET**

Replaces: 27-54014A1, 27-54014Q1, 27-54014T1, 27-54014
For: E, H, TR, TRS

—CONTAINS—

Part #	Description	O.E. No.
18-7175	O-Ring	25-62817
18-2847	Drive Shaft Housing to Bell Housing Gasket	27-54014

① Items ending in "D" are Display Packaged - Regular number is Non-Display

Stern Drive Model	Beginning Serial #	Ending Serial #	Bell Housing Gasket	Bell Housing O-Ring	Bell Housing Rubber Gasket	U-Joint O-Ring (2 Required)	Gasket Set
I	1534570	1684187	—	18-7170	—	18-7153	—
IA	1684188	2062140	18-2556	18-7170	18-2840	18-7153	18-2617
IB	1684633	2062140	18-2556	18-7170	18-2840	18-7153	18-2617
IC	1685240	2065189	18-2556	18-7170	18-2840	18-7153	18-2617
II TR	3377316	4794899	18-2847	18-7175	—	—	18-2620
120	2062141	6225576	18-2820	18-7170	18-2840	18-7153	18-2614
120	6225577	UP	18-2743	18-7170	18-2840	18-7153	18-2619-1
120	6225577	UP	18-2743 ③	18-7170	18-2840	18-7153	18-2619-1
140	2062141	6225576	18-2820	18-7170	18-2840	18-7153	18-2614
140	6225577	UP	18-2743	18-7170	18-2840	18-7153	18-2619-1
140	6225577	UP	18-2743 ③	18-7170	18-2840	18-7153	18-2619-1
160	2065190	2763441	18-2820	18-7170	18-2840	18-7153	18-2614
165	2763442	UP	18-2820	18-7170	18-2840	18-7153	18-2614
170	6225577	UP	18-2743	18-7170	18-2840	18-7153	18-2619-1
170	6225577	UP	18-2743 ③	18-7170	18-2840	18-7153	18-2619-1
185	6225577	UP	18-2743	18-7170	18-2840	18-7153	18-2619-1
185	6225577	UP	18-2743 ③	18-7170	18-2840	18-7153	18-2619-1
190	6225577	UP	18-2743	18-7170	18-2840	18-7153	18-2619-1
190	6225577	UP	18-2743 ③	18-7170	18-2840	18-7153	18-2619-1
200	6225577	UP	18-2743	18-7170	18-2840	18-7153	18-2619-1
200	6225577	UP	18-2743 ③	18-7170	18-2840	18-7153	18-2619-1
215 E/H	2782203	2915034	18-2847	18-7175	—	18-7153 □	18-2620
225	3856268	4200499	18-2820	18-7170	18-2840	18-7153	18-2614
228	4782330	6225576	18-2820	18-7170	18-2840	18-7153	18-2614
228	6225577	UP	18-2743	18-7170	18-2840	18-7153	18-2619-1
228	6225577	UP	18-2743 ③	18-7170	18-2840	18-7153	18-2619-1
230	6225577	UP	18-2743	18-7170	18-2840	18-7153	18-2619-1
230	6225577	UP	18-2743 ③	18-7170	18-2840	18-7153	18-2619-1
233	4200500	UP	18-2820	18-7170	18-2840	18-7153	18-2614
250	4791300	4898729	18-2820	18-7170	18-2840	18-7153	18-2614

① Hydraulic Shift Only ② Borg Warner Transmission Only ③ For housing with oil reservoir check valve

CHART CONTINUED ON NEXT PAGE

Stern Drive Model	Beginning Serial #	Ending Serial #	Bell Housing Gasket	Bell Housing O-Ring	Bell Housing Rubber Gasket	U-Joint O-Ring (2 Required)	Gasket Set
255 TRS	3377316	4203749	18-2847	18-7175	—	—	18-2620
260	4898730	6225576	18-2820	18-7170	18-2840	18-7153	18-2614
260	6225577	UP	18-2743	18-7170	18-2840	18-7153	18-2619-1
260	6225577	UP	18-2743 ③	18-7170	18-2840	18-7153	18-2619-1
280 TRS	4203750	4895399	18-2847	18-7175	—	—	18-2620
470	4208730	6225576	18-2820	18-7170	18-2840	18-7153	18-2614
470	6225577	UP	18-2743	18-7170	18-2840	18-7153	18-2619-1
470	6225577	UP	18-2743 ③	18-7170	18-2840	18-7153	18-2619-1
485	4893835	UP	18-2820	18-7170	18-2840	18-7153	18-2614
488	6225577	UP	18-2743	18-7170	18-2840	18-7153	18-2619-1
488	6225577	UP	18-2743 ③	18-7170	18-2840	18-7153	18-2619-1
888	3106717	UP	18-2820	18-7170	18-2840	18-7153	18-2614
898	4782330	6225576	18-2820	18-7170	18-2840	18-7153	18-2614
898	6225577	UP	18-2743	18-7170	18-2840	18-7153	18-2619-1
898	6225577	UP	18-2743 ③	18-7170	18-2840	18-7153	18-2619-1
R/MR/Alpha One	6225577	UP	18-2743	18-7170	18-2840	18-7153	18-2619-1
R/MRAlpha One	6225577	up	18-2743 ③	18-7170	18-2840	18-7153	18-2619-1
Bravo (I/II)	B664190	UP	18-2516	—	—	18-7153	18-2615
TR-TRS	4794900	UP	18-2847	18-7175	18-2847	18-7153 □	18-2620

① Hydraulic Shift Only ② Borg Warner Transmission Only ③ For housing with oil reservoir check valve

**All Sierra products
meet or exceed the
original equipment part
it replaces.**



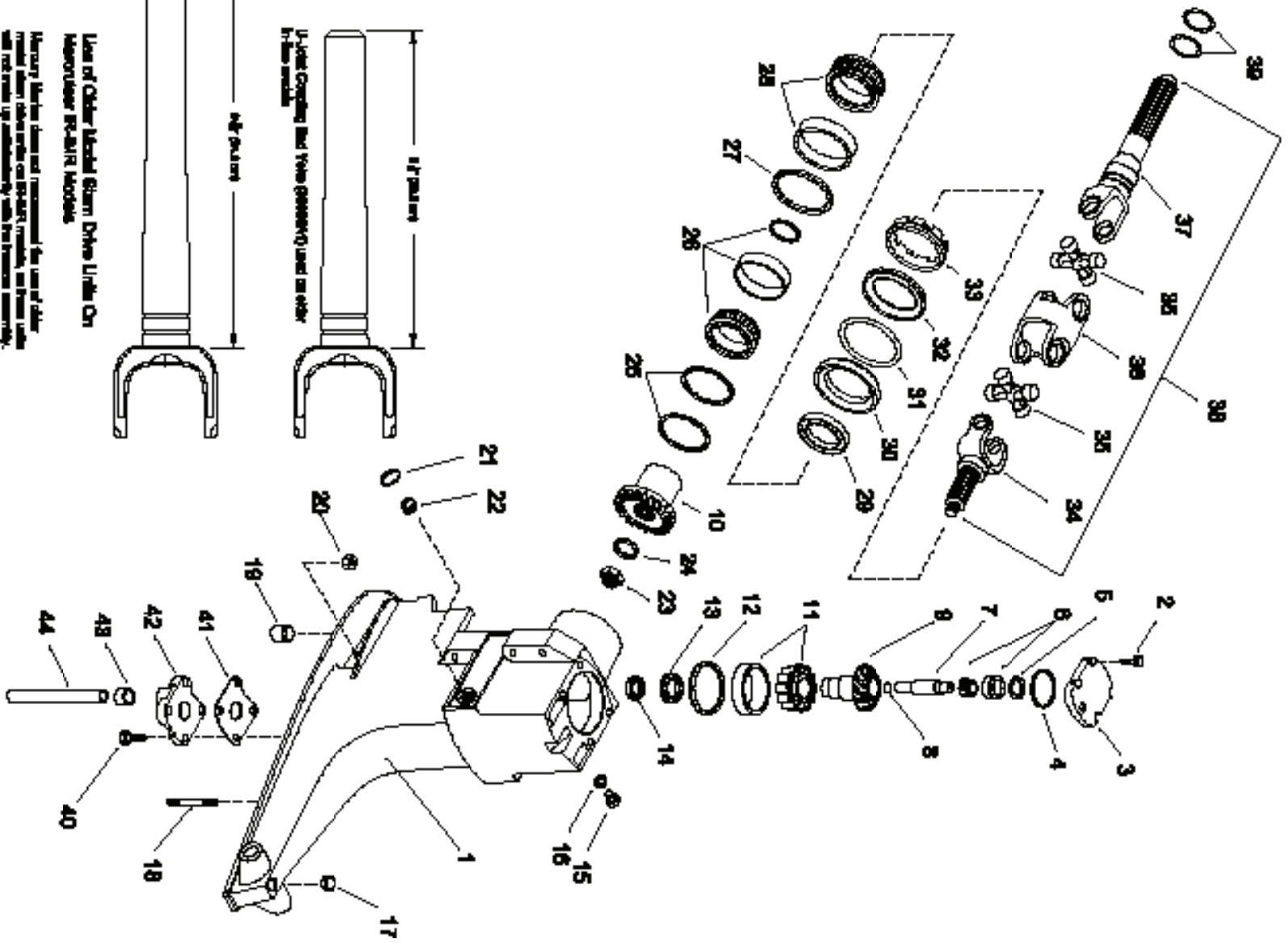

Mercury identifies items not recommended for use of older model items when order on parts, models, or items lists will not result in substitution with the present assembly. In addition, the older model to the item lists are equipped with U-joint coupling and yoke (green). The yoke is either 2 1/2" (63.5mm) or 3" (76.2mm) wide on the flange side (drive end), and 2 1/2" (63.5mm) wide on the other side (propeller end). The yoke is either 2 1/2" (63.5mm) or 3" (76.2mm) wide on the flange side (drive end), and 2 1/2" (63.5mm) wide on the other side (propeller end). The yoke is either 2 1/2" (63.5mm) or 3" (76.2mm) wide on the flange side (drive end), and 2 1/2" (63.5mm) wide on the other side (propeller end).

SEE PAGES 826-827 FOR COMPLETE REPLACEMENT HOUSINGS

Figure #	Description	Part #	OEM #	Qty.
1	Upper Gear Housing	N/A	1547-9412A18	1
2	Screw, Top Cover	18-3231	10-98794	4
3	Top Cover	18-2381	94998A2	1
4	O-Ring, Top Cover	18-7161	25-32546	1
5	Shim, Bearing Cup to Top Cover	18-2283	15-45691A1	1
6	Tapered Roller Bearing	18-1165	31-61100A1	1
7	Upper Drive Shaft	18-2179	45-55796	1
8	O-Ring, Upper Drive Shaft	18-7445	25-55801	1
9./10.	Upper Unit Gear Set			
	1.5:1	18-2201	43-18410A2, 46-18411A2	1
	Rebuild Kit	18-2256	43-803116T1	1
	1.65:1	18-2203	43-45814A5	1
	Rebuild Kit	18-2257	43-803112T1	1
	1.84:1	18-2204	43-75325A3	1
	Rebuild Kit	18-2258	43-803114T1	1
	1.98:1	18-2205	43-55778A3	1
	Rebuild Kit	18-2259	43-803101T1	1
11	Tapered Roller Bearing	18-1161	31-35990A1	1
12	Shim Kit, Bearing Cup to Drive Shaft Housing	18-2293	15-36178A1	1
13	Oil Seal, Upper Drive Shaft Housing	18-2049	26-32511	1
14	Oil Seal, Lower Drive Shaft Housing	18-2056	26-96503	1
15	Vent Screw	18-2244	10-79953A2	1
16	Gasket, Gear Housing Drain Screw	18-2945	12-19183, 12-20260	1
17	Plug, Trim Tab Hole	18-3232	19-47579	1
18	Stud, Drive Shaft Housing	N/A	16-56295	2
19	Bushing, Drive Shaft Housing	18-3236	23-32632	1
20	Nut, Gear Housing Stud	18-2362	11-13439-1	3
21	Welch Plug, Drive Shaft Housing			
	(7/8" OD)	18-4272	19-32652	1
	(1 1/4" OD)	18-4273	19-42682	1
22	Pipe Plug, Water Pocket	18-4265	22-428611	1
23	Nut, Drive Gear to U-Joint	18-3713	11-22339	1
24	Washer, Drive Gear to U-Joint Nut	18-3712	12-45810	1
25	Shim Kit Drive Gear	18-2292	15-35980A1	1
26	Bearing Kit	18-1160	31-35988A2, A12	1
27	Spacer (comes with kit)	18-1160	31-35988A2, A13	1
28	Roller Bearing (comes with kit)	18-1160	31-35988A2, A13	1
29	Oil Seal	18-2003	26-64893	1
30	Carrier Assembly Oil Seal	18-0577	66081A2	1
31	O-Ring	18-7169	25-70937	1
32	Ring, Roller Bearing Retainer	18-4296	35983	1
33	Retaining Nut Drive Shaft Housing	18-3752	816811-1	1
34	Yoke Assembly	18-2125	46020T	1
35	Heavy Duty U-Joint	18-2104	75832A2	1
36	Center Socket	18-2128	39383T	1
37	U-Joint Shaft Coupler	18-2146	59830A1	1
38	Drive Shaft	18-9218	59830A5	1
39	O-Ring	18-7153	25-25439	2
40	Screw, Water Pocket Cover to Drive Shaft Housing	18-3229	10-28668	4
41	Gasket, Water Pocket Cover	18-0894	27-55810	1
42	Water Pocket Cover (Sold as Assembly includes 40-44)	18-3219	42724A3	1
43	Bushing, Water Pump Housing	18-3110	26-38970	1
44	Water Tube	18-3220	32-54236	1

AR As required

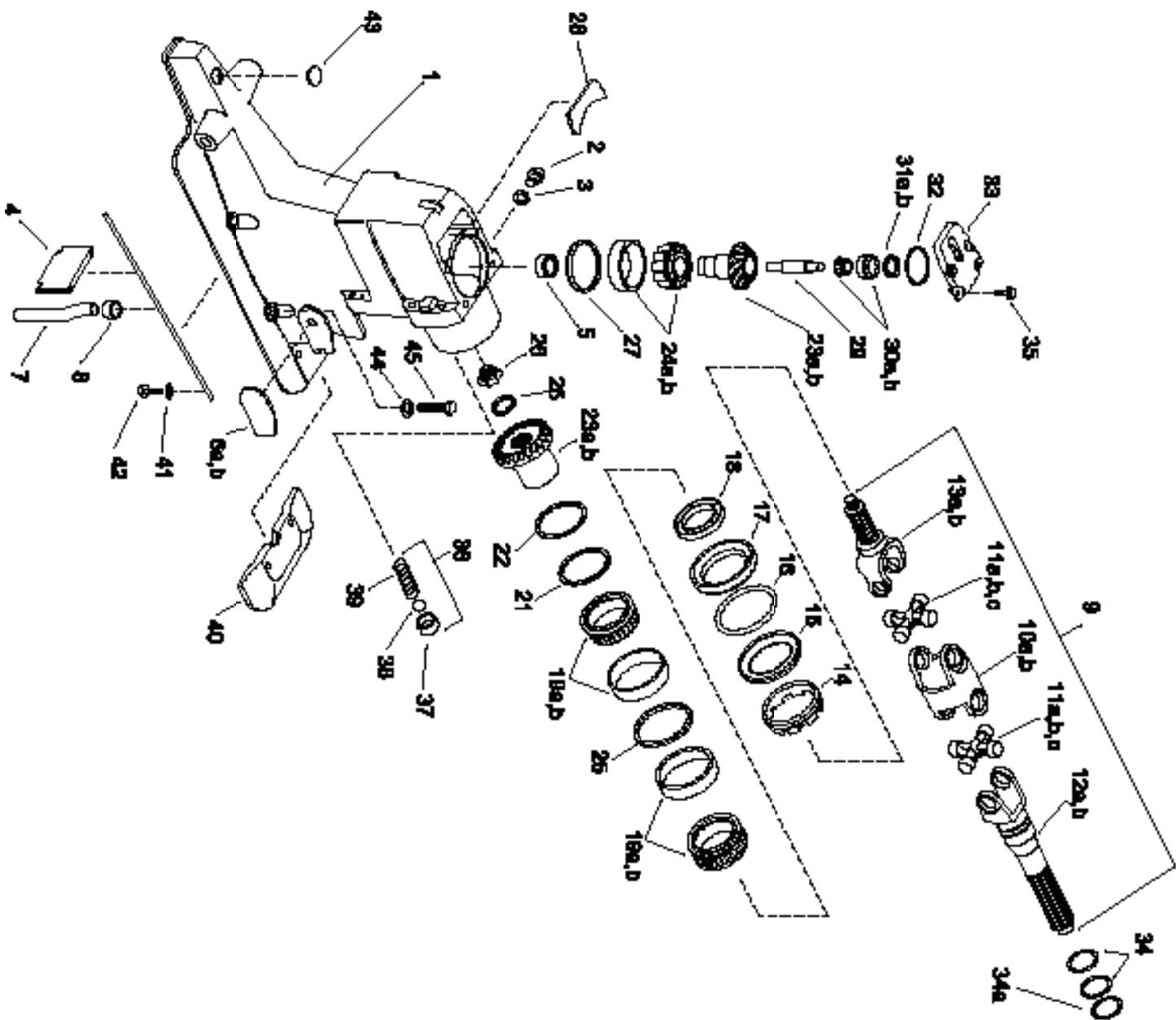

SEE PAGES 826-827 FOR COMPLETE REPLACEMENT HOUSINGS

Figure #	Description	Part #	OEM #	Qty.	Figure #	Description	Part #	OEM #	Qty.
1	Drive Shaft Housing (OL100009 & UP)	18-2411	1547-861063A 4	1		1.84:1/ 1.81:1 Gear Set (tooth count... 17/19)	18-2204	43-75325A3	1
2	Screw	18-2244	10-79953A2	1		Std. Rebuild Kit	18-2258	43-803114T 1	1
3	Washer	18-2945	12-19183, 12-20260	1		Complete Service Kit	18-2365	43-803120 T 1	1
4	Filler Wall	N/A	815932	1		1.98:1/ 1.94:1 Gear Set (tooth count... 20/24)	18-2205	43-55778A3	1
5	Oil Seal	18-2056	26-66302	AR		Std. Rebuild Kit	18-2259	43-803101T 1	1
6a	Wear Pad (Port)	NSS	814386	1		Complete Service Kit	18-2363	43-803118T 1	1
6b	Wear Pad (Stbd)	NSS	814387	1	23a	Upper Unit Gear Set (OL100009 & UP)			
7	Water Tube	18-3221	32-860220	1		1.47:1 Gear Set (tooth count... 20/22)	18-6351	43-853641A2	1
8	Seal	NSS	26-88397	1		Complete Service Kit	18-6351K	43-803103T 1	1
9	Yoke Assembly (OK999999 & Below)	18-9218	814819A2	1		1.62:1 & 2.0:1 Gear Set (tooth count... 24/24)	18-6350	43-853640A2	1
	Yoke Assembly (OL100009 & UP)	NSS	864281A2	1		Complete Service Kit	18-6350K	43-803104T 1	1
10a	Socket, Center (old design)	18-2128	343831, 39383T	1		1.81:1 Gear Set (tooth count... 17/19)	18-6353	43-853643A2	1
10b	Socket, Center GKN Series	NSS	865503T	1		Complete Service Kit	18-6353K	43-803105T 1	1
11	Cross and Bearing					1.94 & 2.4:1 Gear Set (tooth count... 20/24)	18-6352	43-853642A2	1
11a	D469859 - F679999 (old design)	18-2174	75832A2	2		Complete Service Kit	18-6352K	43-803106T 1	1
11b	F680000 - OK999999 (old design- permalube)	18-2097	8055361, 805536A1, 805536A2	2	24	Roller Bearing (All but 1.47:1 ratio)	18-1161	43-803106T 1	1
11c	OL100009 & UP (GKN Series)	18-6406	865493A01	2	24a	Roller Bearing (1.47:1 Ratio only)	18-1142	31-32573A 1	1
12a	Yoke, Coupling End (OK999999 & Below)	18-2146	59830A1	1	25	Washer	18-3712	12-45810	1
12b	Yoke, Coupling End (OL100009 & UP)	NSS	865491A01	1	26	Nut	18-3713	11-22339	1
13a	Yoke, Gear End (OK999999 & Below)	18-2125	46020T	1	27	Shim Kit	18-2293	15-36178A1	1
13b	Yoke, Gear End (OL100009 & UP)	NSS	865492T	1	28	Plug	NSS	861738	1
14	Retaining Nut	18-3752	816811-1	1	29	Drive Shaft, Upper (F680000 & Up)	18-2324	45-55796-1	1
15	Ring	18-4296	35983	1	30	Bearing Assembly			
16	O-Ring	18-7169	25-70937	1	30a	F680000 & UP (small bearing)	18-1179	31-32575A1	1
17	Carrier Assembly (Set)	18-0577	66081A2	1	30b	D494569 - F679999 (large bearing)	18-1165	31-61100A1	1
18	Oil Seal	18-2003	26-68493	1	31	Shim Kit			
19	Roller Bearing Kit (D469859 - K999999)	18-1160	31-35988A2, A12	1	31a	D494569 -F679999	18-2283	15-45691A1	1
19a	Roller Bearing Kit (OL100009 & UP)	18-1182	31-30894A 15	1	31b	F680000 & UP	18-2282	15-32563A1	1
20	Cup Spacer (Included with 18-1160)	18-1160	31-35988A2, A12	AR	32	O-Ring	18-7161	25-32546	1
20a	Cup Spacer (Included with 18-1182)	NSS	23-853649A 1	AR	33	Cover Assembly, Top (F680000 & Up)	18-2382	828692A1	1
21	Shim Kit	18-2292	15-35980A1	1	34	O-Ring	18-7153	25-25439	2
22	Shim Spacer	18-2296	15-71013	1	34a	O-Ring	18-7117	25-35027	1
23	Upper Unit Gear Set (0D469859-0K999999)				35	Screw	18-3231	10-98794	4
	1.5:1/ 1.47:1 Gear Set (tooth count... 20/22)	18-2201	43-18410A2, 43-18411A2	1	36	Check Valve Kit, Oil Passage	18-2715 KIT	24-17997A1	1
	Std.Rebuild Kit	18-2256	43-803116T 1	1	37	Oil Seal (Included in Kit)	NSS	—	1
	Complete Service Kit	18-2358	43-803102T 1	1	38	Ball (Included in Kit)	NSS	—	1
	1.65:1/ 1.62:1 Gear Set (tooth count... 24/24)	18-2203	43-45814A5	1	39	Spring	NSS	—	1
	Std. Rebuild Kit	18-2257	43-803112T 1	1	40	Anode Plate	18-6080	821629A1	1
	Complete Service Kit	18-2364	43-803119T 1	1	41	Lockwasher	N/A	13-78968	2
					42	Screw	18-3229	10-28668	2
					43	Plug	N/A	19-824928	1
					44	Washer	18-4858-9	12-45176	4
					45	Bolt	18-3230	10-816601	4

AR As Required

NSS Not Sold Separate

N/A Not Available

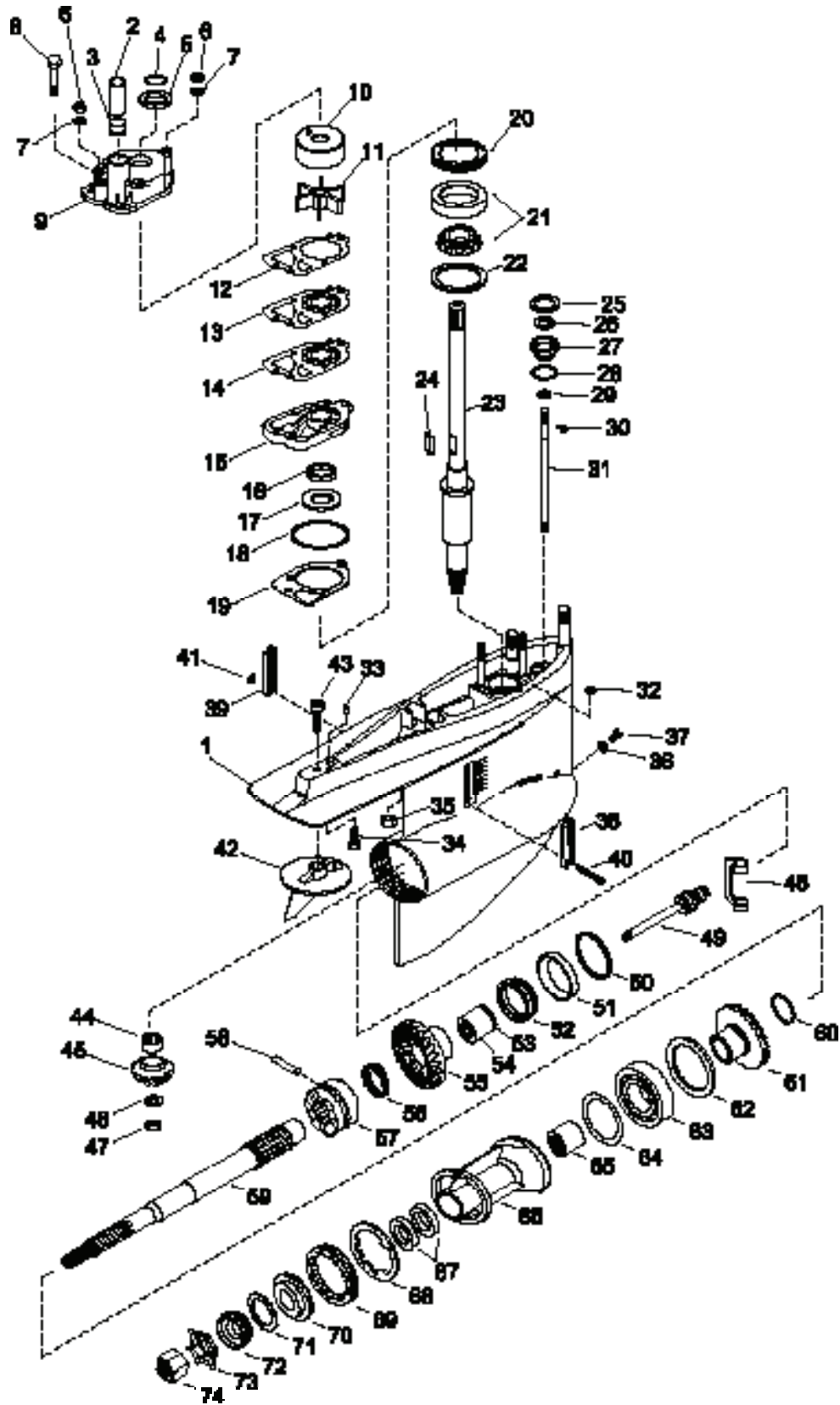

SEE PAGES 826-827 FOR COMPLETE REPLACEMENT HOUSINGS

Figure #	Description	Part #	OEM #	Qty.	Figure #	Description	Part #	OEM #	Qty.
1	Gear Housing	18-2401	1623-8951A37	1	36	Gasket, Gear Housing Drain Screw	18-2945	12-19183, 12-20260	1
2	Water Tube Guide	18-3109	23-29804	1	37	Plug, Oil Fill/Drain	18-2244	10-79953A2	1
3	Bushing/Water Pump Housing	18-3110	26-38970	1	38	Insert, Water Pick (Stbd)	18-3199	93423-1	1
4	O-Ring, Upper Drive Shaft	18-7158	25-30613	1	39	Insert, Water Pick (Port)	118-3198	93424-1	1
5	Slinger	18-7426	25-30271	1	40	Screw, Insert to Gear Housing	18-3197	10-76156	1
6	Stainless Steel Locknuts (5/16-24)	N/A	11-13436	1	41	Nut, Insert Screw	18-2344	11-45812	1
	Stainless Steel Locknuts (1/4-28)	N/A	11-13438	2	42	Trim Tab	18-6011	31640A1	1
7	Washer	18-4270	12-36001	3	43	Screw, Trim Tab Gear Housing	18-6245	10-32470	1
8	Screw, Water Pump Body to Water Pump Base	N/A	10-96411	1	44	Pinion Bearing	18-1117	31-42647A1	1
9	Upper Pump Housing	18-3116	46-96148A1	1	45	Lower Alpha Gear Set (pinion gear)	18-2206	43-17064A2, 43-17064A3, 43-42934	1
10	Insert Cup	18-3114	48752	1	46	Anti-Galling Washer Pinion Gear	18-2343	22-92721	1
11	Impeller	18-3017	47-89984	1	47	Pinion Nut	18-3719	11-35921	1
12	Gasket, Upper Water Pump to Wear Plate	18-2915	27-85609-1	1	48	Shift Crank	18-2130	76865	1
13	Impeller Plate	18-3117	32435	1	49	Shift Spool Assembly	18-2286	818349A1	1
14	Gasket, Wear Plate to Water Pump Base	18-2914	27-85608-1	1	50	Shim Kit, Forward Gear	18-2285	15-47397A1	1
15	Water Pump Base	18-3420	46-44292A3	1	51	Tapered Roller Bearing Set	18-1159	31-35928A1	1
16	Oil Seal (upper)	18-2013	26-16977	1	52	Inner Bearing, Forward Gear	18-1157	31-30895	1
17	Oil Seal (lower)	18-2014	26-89238	1	53	Retaining Clip, Inner Bearing	N/A	—	1
18	O-Ring, Water Pump	18-7176	25-90011	1	54		18-1157	31-30895	1
19	Gasket, Water Pump Base to Gear Housing	18-2919	27-42631-1	1	55	Lower Alpha Gear Set (Forward Gear/Pinion)	18-2206	43-17064A2, 43-17064A3, 43-42934	1
20	Retainer, Drive Shaft Bearing	18-2346	824519	1	56	Spring, Retainer - Cross Pin	18-2348	24-30893	1
21	Tapered Roller Bearing Drive Shaft	18-1143	31-36387A1	1	57	Sliding Clutch	18-2202	52-66063	1
22	Shim Kit, Lower Drive Shaft Bearing	18-2294	15-42637A1	1	58	Cross Pin, Clutch to Actuating Shaft	18-2357	24-30893	1
23	Drive Shaft	18-2180	45-42634	1	59	Propeller Shaft	18-2166	44-66060, 44-6606-3	1
24	Drive Key Water Pump Impeller	N/A	28-56654	1	60	Spacer, Reverse Gear	N/A	23-824108	1
25	Shift Shaft Washer	18-4267	12-29395	1	61	Lower Alpha Gear Set (Reverse Gea-NSS)	18-2206	43-17064A2, 43-17064A3, 43-42934	1
26	Washer Rubber Shift Shaft Bushing	18-2340	12-31266	1	62	Thrust Ring, Bearing Carrier	18-2342	68100-1	1
27	Shift Bushing	18-2154	23-30617A2	1	63	Ball Bearing	18-1155	30-88957A1	1
28	O-Ring, Shift Shaft Bushing	18-7153	25-25439	1	64	O-Ring, Bearing Carrier	18-7159	25-31534	1
29	Washer, Lower Shift Shaft	NSS	12-27880	1	65	Needle Roller Bearing	18-1158	31-30956	1
30	Retaining Clip, Shift Shaft	NSS	53-29641	1	66	Bearing Carrier	18-2191	73020A-14	1
31	Stainless Steel Shift Shaft	18-2150	77481-1	1	67	Oil Seals, Bearing Carrier	18-2002	26-76868	2
32	Oil Passage Seal	18-2944	26-45577	1	68	Tab Washer	18-2298	14-18323	1
33	Dowel Pin, Gear Housing to Drive Shaft Housing	18-3226	10-30720	2	69	Spanner Nut	18-3751	79448	1
34	Screw, Gear Housing to Drive Shaft Housing	18-2361	10-30206	1	70	Thrust Washer	18-4220	13171, 77987	1
35	Nut, Gear Housing to Drive Shaft Housing	18-2362	11-13439-1	2	71	Continuity Washer	N/A	13-423511	1
					72	Brass Castle Washer	18-3714	12-31211A2	1
					73	Tab Washer	18-3200	14-31210, 14-816629	1
					74	Prop Nut	18-3700	11-52707	1

N/A Not Available

NSS Not Sold Separate



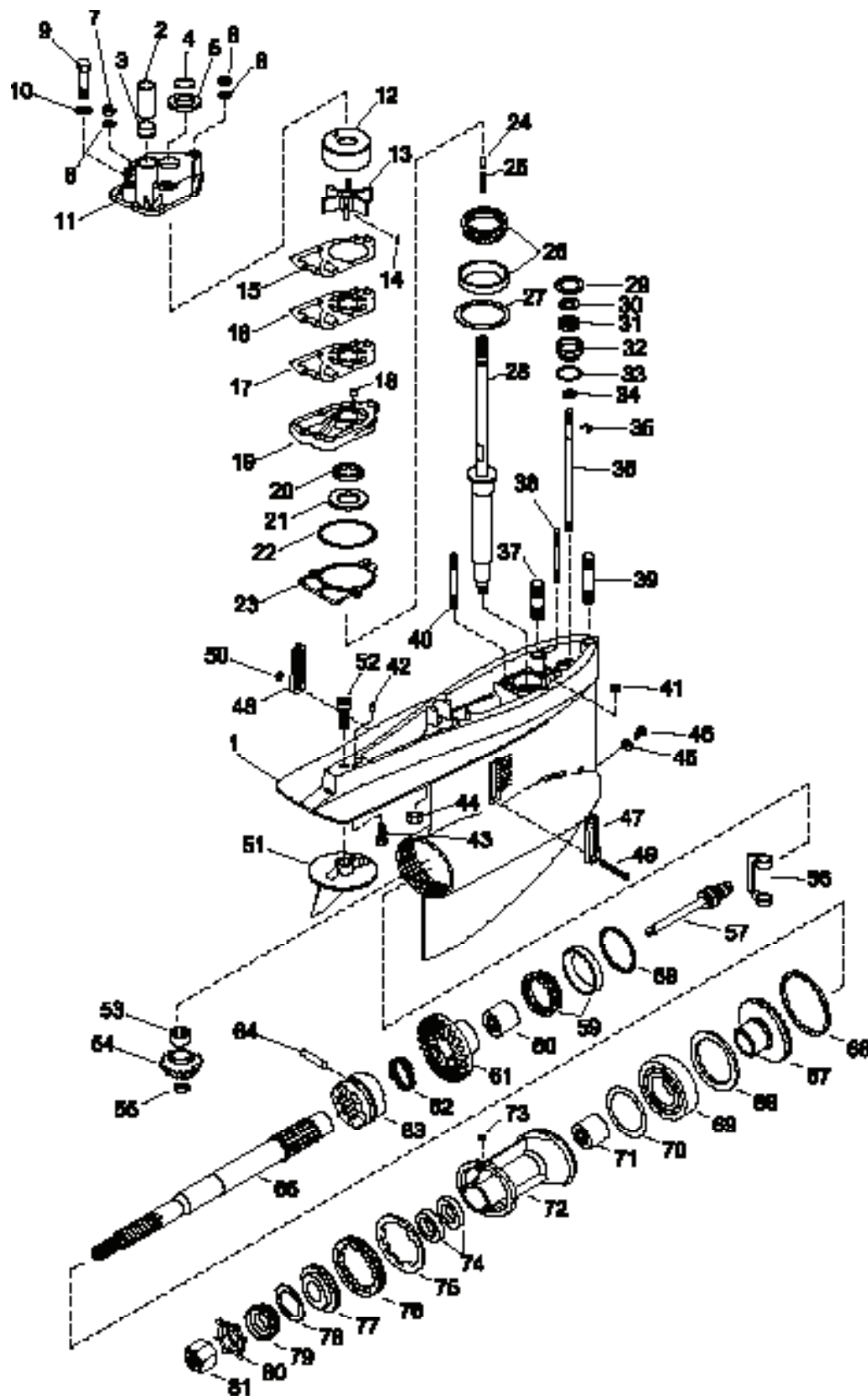

SEE PAGES 826-827 FOR COMPLETE REPLACEMENT HOUSINGS

Figure #	Description	Part #	OEM #	Qty.	Figure #	Description	Part #	OEM #	Qty.
1	Lower Gear Housing	N/A	1623-5356A4	1	41	Oil Passage Seal	18-2944	26-45577	1
2	Water Tube Guide	18-3109	23-29804	1	42	Dowel Pin, Gear Housing to Drive Shaft Housing	N/A	17-35973	2
3	Bush Water Pump Housing	18-3110	26-38970	1	43	Screw, Gear Housing to Drive Shaft Housing	18-2361	10-30206	1
4	O-Ring, Upper - Drive Shaft	18-7158	25-30613	1	44	Nut Gear Housing to Drive Shaft Housing	N/A	11-82671015	2
5	Slinger	18-7426	25-30271	1	45	Gasket, Gear Housing Drain Screw	18-2945	12-19183, 12-20260	1
6	Stainless Steel Locknuts (5/16-24)	18-3723	11-45592	1	46	Plug, Oil Fill/Drain	18-2244	10-79953A2	1
7	Stainless Steel Locknuts (1/4-28)	18-3722	11-20361, 11-35888	2	47	Insert, Water Pick (Stbd)	N/A	66885	1
8	Washer	18-4275	12-29245	3	48	Insert, Water Pick (Port)	N/A	66884	1
9	Screw	18-3226	10-30720	1	49	Screw Insert to Gear Housing	18-3197	10-76156	1
10	Washer, Water Pump Body	18-4270	12-36001	1	50	Nut, Insert Screw	18-2344	11-45812	1
11	Upper Pump Housing	18-3116	46-96148A1	1	51	Trim Tab	18-6011	31640A1	1
12	Insert Cup	18-3114	48752	1	52	Screw, Trim Tab to Gear Housing	18-6245	10-32470	1
13	Impeller	18-3017	47-89984	1	53	Needle Roller Bearing	18-1150	31-92366A1	1
14	Drive Key	N/A	28-56654	1	54	Lower Unit Gear Set (pinion gear)	18-2200	23-96084A4	1
15	Gasket, Upper Water Pump to Wear Plate (upper)	18-2915	27-85609-1	1	55	Pinion Nut	18-3719	11-35921	1
16	Impeller Plate	18-3117	32435	1	56	Shift Crank	18-2130	76865	1
17	Gasket, Upper Water Pump to Wear Plate (lower)	18-2914	27-85608-1	1	57	Shift Spool Assembly	19755A2	18-2286	1
18	Dowel Pin	18-3227	17-35973	2	58	Shim Kit, Forward Gear Bearing	18-2285	15-47397A1	1
19	Water Pump Base	18-3417	46-57234A1	1	59	Tapered Roller Bearing	18-1159	31-35928A1	1
20	Oil Seal (upper)	18-2026	26-16977	1	60	Needle Roller Bearing	18-1157	31-30895	1
21	Oil Seal (lower)	18-2014	26-89238	1	61	Lower Unit Gear Set (Forward)	18-2200	23-96084A4	1
22	O-Ring (2.175 ID) & (2.1091 ID)	18-7176, 18-7196	25-90011	1	62	Spring, Retainer, Cross Pin	18-2348	24-30893	1
23	Gasket, Water Pump Base to Gear Housing	18-2826	27-85610-1	1	63	Sliding Clutch	18-2202	52-66063	1
24	Pin, Driveshaft	N/A	17-30545	1	64	Cross Pin, Clutch to Clutch Actuating Shaft	18-2348	17-30632	1
25	Spring	N/A	24-34576	1	65	Propeller Shaft	18-2166	44-66060, 44-66060-3	1
26	Tapered Roller Bearing	N/A	31-53079A1	1	66	Shim Kit, Thrust Ring to Gear Housing	18-2284	15-31535A1	1
27	Shim Kit, Drive Shaft Bearing	18-2295	15-57007A	1	67	Lower Unit Gear Set (reverse)	18-2200	43-96084A4	1
28	Drive Shaft	N/A	45-41939A1	1	68	Thrust Ring, Bearing Carrier	18-3759	35915	1
29	Shift Shaft Washer	18-4267	12-29395	1	69	Ball Bearing	18-1155	30-88957A1	1
30	Washer, Rubber Shift Shaft Bushing	18-2340	12-31266	1	70	O-Ring	18-7159	25-31534	1
31	Oil Seal	26-89236	18-2009	1	71	Needle Roller Bearing	18-1158	31-30956	1
32	Shift Bushing	18-2154	23-30617A2	1	72	Bearing Carrier Assembly	18-2191	73020A14	1
33	O-Ring	18-7153	25-25439	1	73	Key, Locating - Bearing Carrier	N/A	28-30281	1
34	Washer, Lower Shift Shaft Bushing	N/A	12-27880	1	74	Oil Seals	18-2002	26-76868	2
35	Retaining Clip, Shift Shaft	18-4295	53-29641	1	75	Tab Washer	18-2299	14-79447	1
36	Stainless Steel Shift Shaft	18-2150	77481-1	1	76	Spanner Nut	18-3751	79448	1
37	Stud, Gear Housing to Drive Shaft Housing (1-31/32")	N/A	16-56298	2	77	Thrust Washer	18-4220	13171, 77987	1
38	Stud, Water Pump to Gear Housing (3 - 3/8")	N/A	16-562972	1	78	Continuity Washer	NSS	13-423511	1
39	Stud, Gear Housing to Drive Shaft Housing (3 - 3/16")	N/A	16-46911	1	79	Brass Castle Washer	18-3714	12-31211A2	1
40	Stud, Water Pump to Gear Housing (3 - 1/4")	N/A	16-69501	2	80	Tab Washer	18-3200	14-31210, 14-816629	1
					81	Prop Nut	18-3700	11-52707	1

AR As required NSS Not Sold Seperate



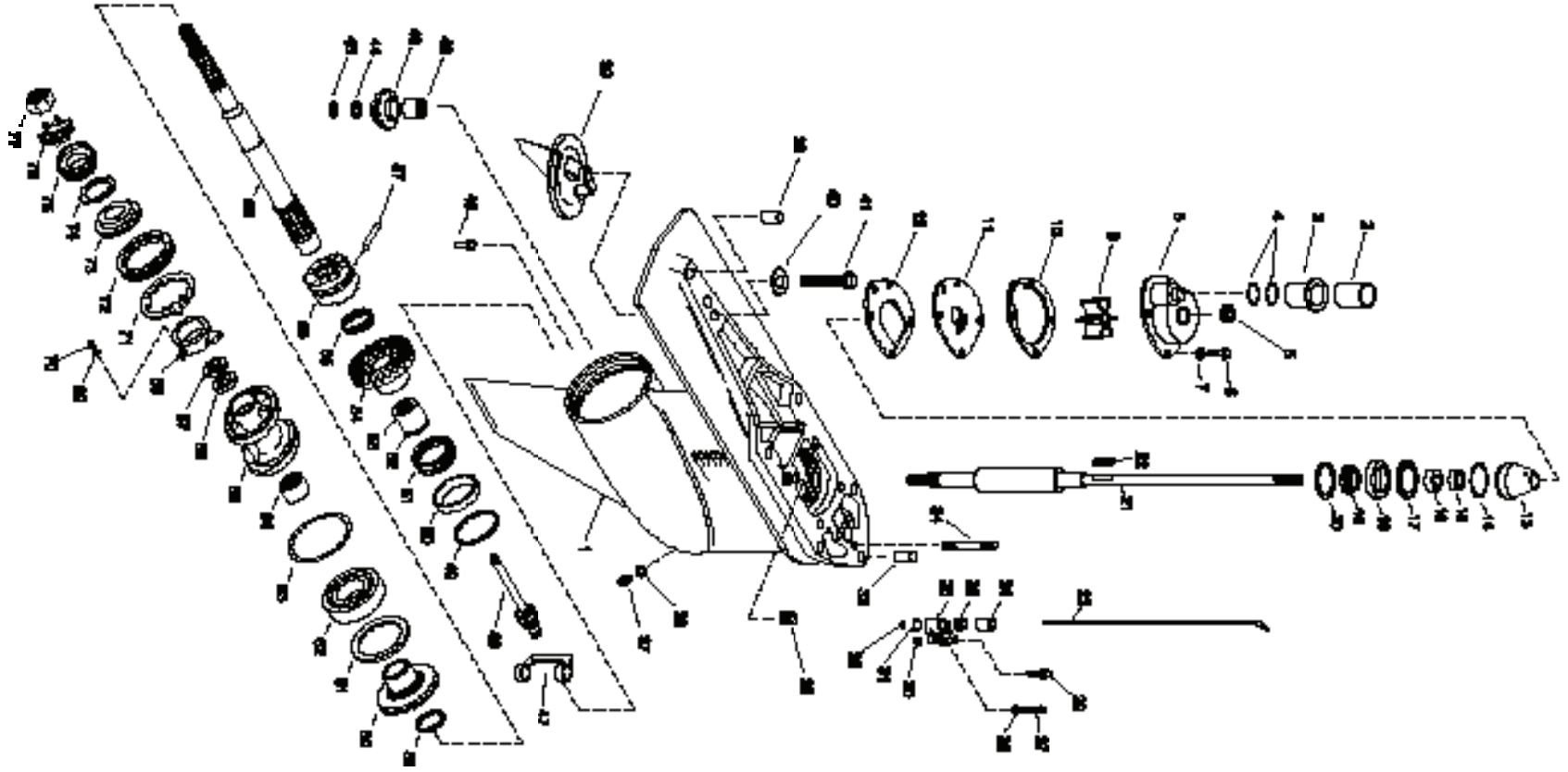

SEE PAGES 826-827 FOR COMPLETE REPLACEMENT HOUSINGS

Figure #	Description	Part #	OEM #	Qty.	Figure #	Description	Part #	OEM #	Qty.
1	Gear Housing	18-2415	1623-815822A36	1	39	Trim Tab	18-6016	76214A5	1
2	Sleeve	—	23-816573	1	40	Washer, Anode Mounting	—	13-806210	1
3	Coupling	18-3151	816597A1	1	41	Bolt, Anode Mounting	—	10-806327	1
4	O-Rings	18-7420	25-21836	2	42	Pinion Bearing	18-1117	31-42647A1	1
5	Face Seal	18-2599	26-816575A2	1	43	Pinion Gear	18-2206	43-828072A2	1
6	Screw, 10-32 X 5/8	NSS	10-816928	4	44	Washer	18-2343	12-92721	1
7	Star Washer	NSS	13-69432	4	45	Nut	18-3719	11-35921	1
8	Water Pump Body	18-3147	817275A1	1	46	Pin	—	17-37972-1	1
9	Impeller	18-3056	47-43026-2	1	47	Shift Crank	18-2130	76865	1
10	Gasket	18-2563	27-817277	1	48	Shift Spool Assembly	18-2286	818349A1	1
11	Face Plate	18-3122	817276	1	49	Shim Kit	18-2285	15-47397A1	1
12	Gasket	18-2564	27-43033-1	1	50 & 51	Forward Gear, Outer Bearing	18-1159	31-35928A1	1
13	Seal Carrier	18-2354	821759A2	1	52	Retaining Clip, Inner Bearing	NSS	—	1
14	O-Ring	18-7176	25-90011	1	53	Forward Gear, Inner Bearing	18-1157	31-30895	1
15	Seal	18-2013	26-16977	1	54	Forward Gear	18-2206	43-828072A2	1
16	Seal	18-2014	26-89238	1	55	Cross Pin Spring	18-2348	24-30893	1
17	Cover Nut	18-2346	824519	1	56	Sliding Clutch	18-2202	52-824112	1
18 & 19	Bearing, Upper Driveshaft (1.50-1.65 Ratio)	18-1143	31-36387A1	1	57	Cross Pin	18-2357	17-30632	1
20	Shim Kit	18-2294	15-42637A1	1	58	Propeller Shaft	18-2166	44-824110	1
21	Drive Shaft (1:47 & 1:62)	18-2331	45-853648	1	59	Spacer	—	23-824108	1
	Drive Shaft (1:50 & 1:65)	18-2261	45-816919	1	60	Reverse Gear	18-2206	43-828072A2	1
	Drive Shaft (1:84 & 1:98) (Early Style use with 18-1143)	—	45-816472	1	61	Thrust Ring	18-2342	681001	1
22	Impeller Drive Key	18-3293	28-43037	1	62	Ball Bearing	18-1155	30-88957A1	1
23	Shift Shaft	18-2320	815919A1	1	63	O-Ring	18-7159	25-31534	1
24	Sleeve	18-2349	23-67370	1	64	Roller Bearing	18-1158	31-30956	1
25	Seal	18-2009	26-89236	1	65	Bearing Carrier	18-2376	818763A10	1
26	Shift Rod Bushing Assembly	18-2353	23-815921A21	1	66	Seal	18-2002	26-14077	1
27	Screw, 10-32 X 5/8	NSS	10-806290	2	67	Seal	18-2076	26-12224	1
28	Star Washer	NSS	13-69432	2	68	Carrier Anode	18-6093	806105A1	1
29	Speedometer Pickup Fitting	—	NSS	1	69	Lockwasher, Anode Mounting	—	13-69432	2
30	O-Ring	18-7440-1	25-36318	1	70	Bolt, Anode Mounting	—	10-806290	2
31	O-Ring	18-7440-1	25-36318	1	71	Tab Washer	18-2298	14-18323	1
32	Retaining Ring	18-4295	53-29641	1	72	Cover Nut	18-3751	79448	1
33	Dowel Pin	—	17-43044	1	73	Thrust Hub	18-4220	13171	1
34	Stud, Mounting	—	16-57984	1	74	Continuity Washer	NSS	13-42351-1	1
35	Seal	18-2944	26-45577	1	75	Splined Washer	18-3714	12-31211A2	1
36	Dowel Pin	—	17-43044	1	76	Tab Washer	18-3200	14-31210	1
37	Plug	18-2375	22-67892A1	1	77	Propeller Nut	18-3700	11-52707	1
38	Gasket	18-2945	12-19183	1		Seal Kit (Not Pictured)	18-2646-1	26-816575A3	1

NSS Not Sold Separate





18-2292 SHIM KIT

Drive Gear
Replaces: 15-35980A1
 Contains (1) each
 .002, .003, .005, .006, .010, .025
For: Mercruiser Vazer



18-2293 SHIM KIT

Upper Bearing
Replaces: 15-36178A1, 15-36178A02, 15-39899A1, 15-23097A1
 Contains (1) each .002, .003, .015
 (2) each .010
For: Mercruiser Vazer



18-2294 SHIM KIT

Lower Drive Shaft Bearing
Replaces: 15-8M0063267, 15-42637A1
 Contains (1) each
 .002, .003, .005, .010, .020
For: Mercruiser Vazer



18-2295 SHIM KIT

Lower Drive Shaft Bearing
Replaces: 15-57007A1, 15-33143A1
 Contains (1) each
 .002, .003, .005, .010, .020
For: Mercruiser Vazer

SHIMS

Part No.	Size	O.E. #
18-0208	.208	23-1761515 ⑥
18-0210	.210	23-1761516 ⑥
18-0212	.212	23-1761517 ⑥
18-0214	.214	23-1761518 ⑥
18-0216	.216	23-1761519 ⑥
18-0218	.218	23-1761520 ⑥
18-0230	.230	23-1761526 ⑥
18-0222	.222	23-1761522 ⑥
18-0224	.224	23-1761523 ⑥
18-0226	.226	23-1761524 ⑥



Part No.	Size	O.E. #
*18-2282	Kit	15-32563A1 • For: Mercruiser Vazer
*18-2283	Kit	15-45691A1
*18-2284	Kit	15-31535A1
*18-2285	Kit	15-35931A1, 15-47397A1
*18-2296	.055	15-71013, 15-45811
* 18-2282	(1) each	.002, .003, .005, .010, .025
* 18-2283	(1) each	.002, .003, .005, .010
* 18-2284	(1) each	.002, .003, .005, .010, .020
* 18-2285	(1) each	.002, .003, .005, .010, .020

SHIM KIT APPLICATION

HP	Serial No.	Bearing to Top Cover Kit	Bearing Cup to Drive Shaft Housing	Drive Gear	Drive Gear Spacer	Drive Shaft Bearing to Gear Housing	Reverse Gear	Forward Gear Kit
120/140	2062141 thru 2791956	18-2282 ②	18-2293	18-2292	18-2296	18-2295	18-2284 ⑤	18-2285
120/140	2791957 thru 4893634	18-2283 ④	18-2293	18-2292	18-2296	18-2295	18-2284 ⑤	18-2285
120/140	4893635 thru 6225576	18-2283	18-2293	18-2292	18-2296	18-2295	—	18-2285
160	2065190 thru 2763441	18-2282 ②	18-2293	18-2292	18-2296	18-2295	18-2284 ⑤	18-2285
165	2763442 thru 4890459	18-2283 ④	18-2293	18-2292	18-2296	18-2295	18-2284 ⑤	18-2285
165	4890460 & UP	18-2283	18-2293	18-2292	18-2296	18-2295	—	18-2285
888	3106717 & UP	18-2283 ③	18-2293	18-2292	18-2296	18-2295	18-2284 ⑤	18-2285
898/228	4782330 thru 4898729	18-2283	18-2293	18-2292	18-2296	18-2295	18-2284 ⑤	18-2285
898/228	4898730 thru 6225576	18-2283	18-2293	18-2292	18-2296	18-2295	—	18-2285
225-S	3856268 thru 4200499	18-2283	18-2293	18-2292	18-2296	18-2295	18-2284 ⑤	18-2285
233	4200500 & UP	18-2283	18-2293	18-2292	18-2296	18-2295	18-2284 ⑤	18-2285
250	4791300 thru 4898729	18-2283	18-2293	18-2292	18-2296	18-2295	18-2284 ⑤	18-2285
260	4898730 thru 6225576	18-2283	18-2293	18-2292	18-2296	18-2295	—	18-2285
470	4208730 thru 4893934	18-2283	18-2293	18-2292	18-2296	18-2295	18-2284 ⑤	18-2285
470	4893835 thru 6225576	18-2283	18-2293	18-2292	18-2296	18-2295	—	18-2285
485	4893835 & UP	18-2283	18-2293	18-2292	18-2296	18-2295	—	18-2285
R/MR/Alpha One	6225577 & UP (R)	18-2283	18-2293	18-2292	18-2296	18-2295	—	18-2285
R/MR/Alpha One	6225577 & UP (MR)	18-2283	18-2293	18-2292	18-2296	18-2294	⑥	18-2285
Alpha Gen II	D494569 thru F679999	18-2283	18-2293	18-2292	18-2296	18-2294	⑥	18-2285
Alpha Gen II	F680000 & UP	18-2282	18-2293	18-2292	18-2296	18-2296	18-2294 ⑥	—

② S/N #2187468 & Below use 18-2293 ③ S/N #4433200 & UP Only ④ S/N #4530702 & UP Only ⑤ Kit ⑥ For Counter Rotation Only

18-2400 COMPLETE LOWER GEAR CASE

Replaces: 1623-815822A53, 1623-815822A5, 1623-815822A32, 1623-815822A43
For: Ratios 1.47, 1.62, 1.81 & 1.94
Fits: Gen II (1998 & up) 0L100040 & up



18-2411 DRIVE SHAFT HOUSING ASSEMBLY

Replaces: 1547-861063A4
For: Gen II Upper (1998-up), 0L100040-up, 1.47:1 Ratio/Gen II Upper (1998-up) 0L100040-up, 1.62/2.00:1 Ratio/s/Gen II Upper (1998-up), 0L100040-up, 1.81:1 Ratio/Gen II Upper (1998-up), 0L100040-up, 1.94/2.40:1 Ratios
Used with: 18-2416, 18-2419 Complete Upper Gear Cases



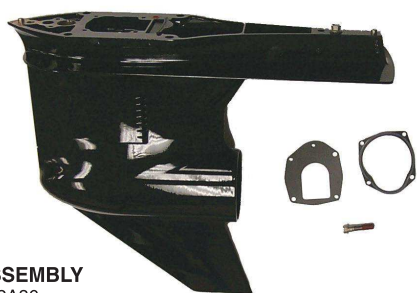

18-2415
GEAR HOUSING ASSEMBLY
Replaces: 1623-815822A36
For: Ratios 1.47, 1.62
 Gen II (1998 & up), (OL100040 & up)
 Used with: **18-2400** Complete Lower Gear Case



18-2416
COMPLETE UPPER GEAR CASE
Replaces: 1547-815930A16, 1547-815930A6, 1547-861063A12
For: Alpha Gen II (1991 & UP) for gear ratios 1.47:1, 1.50:1
 Used with **18-2411** Drive Shaft Housing Assembly



18-2419
COMPLETE UPPER GEAR CASE
Replaces: 1547-815930A13, 1547-815930A3, 1547-861063A6
For: Alpha Gen II (1991 & UP) for gear ratios 1.98:1, 2.40:1
 Used with **18-2411** Drive Shaft Housing Assembly

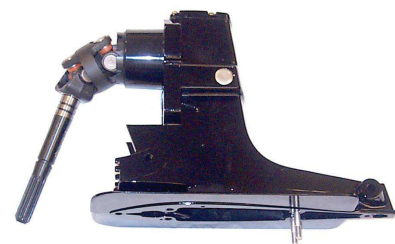

18-2450
COMPLETE UPPER GEAR CASE
Replaces: 1547-9412A20, 1547-3917A13, 1547-3917A21, 1547-3917A32, 1547-3917A37, 1547-5523A2, 1547-5523A9, 1547-5523A12, 1547-5523A68, 1547-8265A15, 1547-9412A30, 1547-9412A35
For: Alpha I
 1.5:1/1.47:1



18-2451
COMPLETE UPPER GEAR CASE
Replaces: 1547-9412A21, 1547-3917A4, 1547-3917A8, 1547-3917A16, 1547-3917A30, 1547-3917A38, 1547-5523A8, 1547-5523A11, 1547-8265A16
For: Alpha I
 1.65:1/1.62:1



18-2452
COMPLETE UPPER GEAR CASE
Replaces: 1547-9412A22, 1547-5523A67, 1547-8265A17, 1547-9412A36
For: Alpha I
 1.84:1/1.81:1



18-2453
COMPLETE UPPER GEAR CASE
Replaces: 1547-9412A23, 1547-5523A49, 1547-5523A67, 1547-8265A17
For: Alpha I
 1.98:1/1.94:1

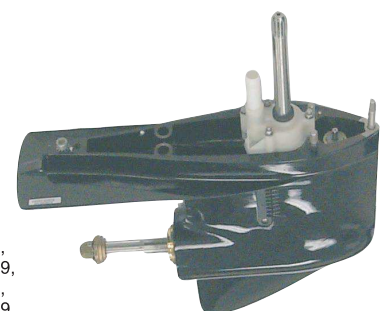

18-2443
COMPLETE LOWER GEAR CASE
Replaces: 1623-8951A43, 1623-4110A4, 1623-4110A6, 1623-4110A13, 1623-5356A3, 1623-5356A18, 1623-5356A19, 1623-5356A20, 1623-8951A2, 1623-8951A14, 1623-8951A19, 1623-8951A23
For: R/MR/ALPHA 1



18-2401
LOWER GEAR HOUSING
Replaces: 1623-8951A27, 1623-8951A37, 1623-8951A5, 1623-8951A15
For: MR/ALPHA Style
 Bore size 3.2635-3.2650. Includes tapered roller bearing for non-tractor 14/28 or 17/28 gears. When installing new gears use **18-2206-1** gear kit which includes tapered roller bearing **18-1156** for tractor 13/21 gears.



18-2402
LOWER GEAR HOUSING
Replaces: 1623-5356A4
For: R Style



18-2368
LOWER GEARCASE KIT
 Replaces: 43-803069T1
 ALPHA/Gen II 1991-95



18-2369
LOWER GEARCASE KIT
 Replaces: 43-803069T1
 ALPHA/Gen II 1991-95

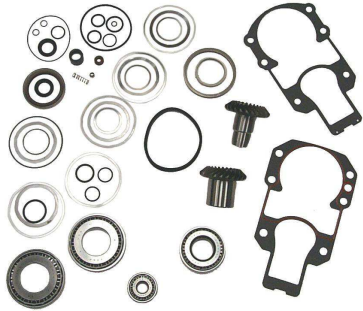

18-2358
UPPER UNIT GEAR REPAIR KIT
 Replaces: 43-803102T1
 For: 20-22 Teeth: 1.50:1 (1.47:1)
 Gen II applications serial number range up to OK999999 only



18-2363
UPPER UNIT GEAR REPAIR KIT
 Replaces: 43-803118T1
 For: 20-24 Teeth: 1.98:1 (1.94/2.40:1)
 Gen II applications serial number range up to OK999999 only



18-2364
UPPER UNIT GEAR REPAIR KIT
 Replaces: 43-803119T1
 For: 24-24 Teeth: 1.65:1 (1.62:1)
 Gen II applications serial number range up to OK999999 only

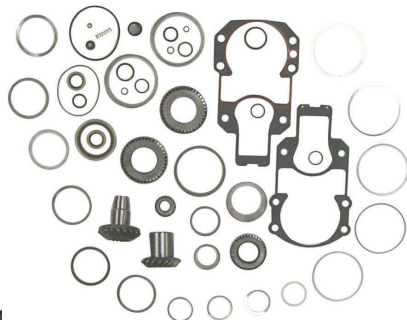

18-2365
UPPER UNIT GEAR REPAIR KIT
 Replaces: 43-803120T1
 For: 17-19 Teeth: 1.84:1 (1.81:1)
 Gen II applications serial number range up to OK999999 only



18-6350K
UPPER UNIT GEAR REPAIR KIT
 Replaces: 43-803104T1
 For: Gen II (1998 & Up)(S/N OL100040 & Up)
 1.62:1 and 2.00:1 Ratio



18-6351K
UPPER UNIT GEAR REPAIR KIT
 Replaces: 43-803103T1
 For: Gen II (1998 & Up)(S/N OL100040 & Up)
 1.47:1 Ratio



18-6352K
UPPER UNIT GEAR REPAIR KIT
 Replaces: 43-803106T1
 For: Gen II (1998 & Up)(S/N OL100040 & Up)
 1.94:1 and 2.40:1 Ratio



18-6353K
UPPER UNIT GEAR REPAIR KIT
 Replaces: 43-803105T1
 For: Gen II (1998 & Up)(S/N OL100040 & Up)
 1.81:1 Ratio



18-2204
UPPER UNIT GEAR SET
Replaces: 43-75325A3, 43-75325A2
(1.84:1 Ratio)
(Drive Gear = 17 teeth Driven Gear = 19 teeth)
For: V-6 and 470/485 (4 Cyl. etc.) and Gen II (S/N K999999 & BELOW)



18-2205
UPPER UNIT GEAR SET
Replaces: 43-55778A3, 43-55766A2, 43-55766A3
(1.98:1 Ratio)
(Drive Gear = 20 teeth Driven Gear = 24 teeth)
For: 120/140 (S/N 2791957 & UP) and Gen II (S/N K999999 & BELOW)



18-6350
UPPER UNIT GEAR SET
Replaces: 43-853640A2, 43-821823A1
For: Gen II Upper (1998-up), 0L100040-up, 1.62/2.00:1 Ratios (24-24 Teeth)

18-2201
UPPER UNIT GEAR SET
Replaces: 43-18410A2, 43-18411A2, 43-59832A2, A4
Includes: (1) **18-1142**
 Mercruiser #31-32573A1
(1.5:1 Ratio)
(Drive Gear = 22 teeth Driven Gear = 20 teeth)
For most V-8 Drives and Gen II (S/N K999999 & BELOW)

Stern Drive Model	Beg. S/N	End. S/N
225	3856268	4200499
260	4898730	6225576
898/228	4782330	6225576
Stern Drive Model	Beg. S/N	End. S/N
888	3106717	& UP
V8R/MR/AlphaOne	6225577	& UP



18-2203
UPPER UNIT GEAR SET
Replaces: 43-45814A5, 43-55765A2, 43-55765A3
(1.65:1 Ratio) (Drive Gear = 24 teeth Driven Gear = 24 teeth)
For: 6 Cyl. Inline S/N K999999 & BELOW



18-6351
UPPER UNIT GEAR SET
Replaces: 43-853641A2
For: Alpha I (Gen II) (1998-up), 0L100040-up, 1.47:1 Ratio (20-22 Teeth)
Used with: 18-2416 Complete Upper Gear Case



18-6352
UPPER UNIT GEAR SET
Replaces: 43-853642A2
For: Alpha I (Gen II) (1998-up), 0L100040-up, 1.94:1, 2.40:1 Ratios (20-24 Teeth)
For: Mercruiser Vazer
Used with: 18-2411 Drive Shaft Housing Assembly, 18-2419 Complete Upper Gear Case



18-6353
UPPER GEAR KIT
Replaces: 43-853643A2
1.81 Ratio Upper Gear Set, 17-19 Teeth
For: Alpha I Gen II 1998-up/0L00040-up
For: Mercruiser Vazer



18-2201
UPPER UNIT GEAR SET
Replaces: 43-18410A2, 43-18411A2, 43-59832A2, A4
Includes: (1) **18-1142**
 Mercruiser #31-32573A1
(1.5:1 Ratio)
(Drive Gear = 22 teeth Driven Gear = 20 teeth)
For most V-8 Drives and Gen II (S/N K999999 & BELOW)

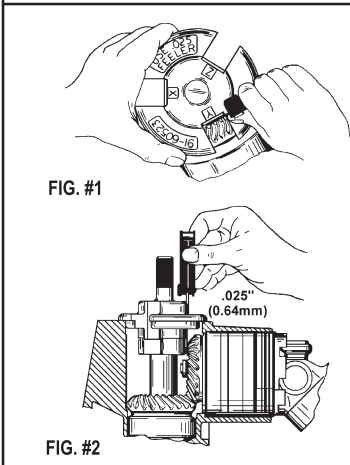



FIGURES #1 - #2
 Provides two separate views of the upper gear housing driven gear being properly shimmed using the Sierra installation tools.

FIGURES #3 - #4
 Provides the same views of the drive gear being shimmed in the same application.

NOTE:
 This installation **cannot** be performed correctly without the Sierra **18-9856** shim tool. Improper installation **will** result in gear failure. The .025 referenced in **FIG #2** & **FIG #4** is achieved when .026 will not fit the clearance but .025 will.

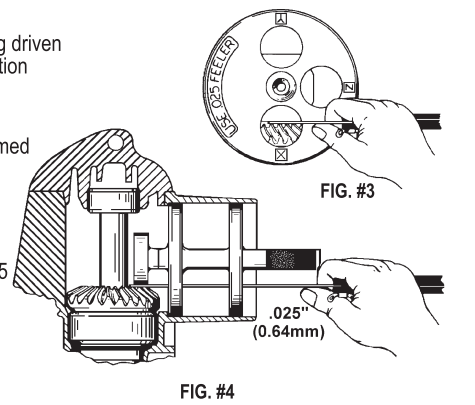
A service manual should always be consulted for step-by-step instructions.

18-2256
UPPER GEAR KIT
Replaces: 43-803116T1
Most V-8 Drives (1.5:1 Ratio)

— CONTAINS —

Part #	Description	O.E. #	Qty.
18-2201	Upper Unit Gear Set	43-18410A2	1
18-2648	Seal Kit	26-32511A2	1
18-2619-1	Outdrive Gasket Set	27-94996A1	1
18-2820	Drive Shaft Housing to Bell Housing Gasket	27-64818	1
18-2743	Drive Shaft Housing to Bell Housing Gasket	27-94996-2	1
18-1160	Bearing	31-35988A2	1
18-1165	Bearing	31-61100A1	1
18-1142	Bearing	31-35990A1	1

— CONTAINS —

Part #	Description	O.E. #	Qty.
18-2203	Gear Set	43-45814A5	1
18-2648	Seal Kit	26-32511A2	1
18-2619-1	Outdrive Gasket Set	27-94996A1	1
18-2820	Drive Shaft Housing to Bell Housing Gasket	27-64818	1
18-1160	Bearing	31-35988A2	1
18-1161	Bearing	31-35990A1	1
18-1165	Bearing	31-61100A1	1
18-2743	Drive Shaft Housing to Bell Housing Gasket	27-94996-2	1

**18-2257
UPPER GEAR KIT**
Replaces: 43-803112T1
6 Cyl. Inline (1.65:1 Ratio)



— CONTAINS —

Part #	Description	O.E. #	Qty.
18-2204	Gear Set	43-75325A3	1
18-2648	Seal Kit	26-32511A2	1
18-2619-1	Outdrive Gasket Set	27-94996A1	1
18-2820	Drive Shaft Housing to Bell Housing Gasket	27-64818	1
18-1160	Bearing	31-35988A2	1
18-1161	Bearing	31-35990A1	1
18-2743	Drive Shaft Housing to Bell Housing Gasket	27-94996-2	1
18-1165	Bearing	31-61100A1	1

**18-2258
UPPER GEAR KIT**
Replaces: 43-803114T1
V-6 (470/485) (1.84:1 Ratio)

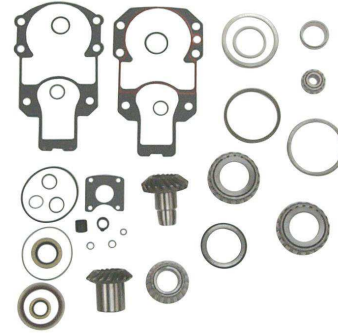

— CONTAINS —

Part #	Description	O.E. #	Qty.
18-2205	Gear Set	43-55778A3	1
18-2648	Seal Kit	26-32511A2	1
18-2619-1	Outdrive Gasket Set	27-94996A1	1
18-2820	Drive Shaft Housing to Bell Housing Gasket	27-64818	1
18-1160	Bearing	31-35988A2	1
18-1161	Bearing	31-35990A1	1
18-1165	Bearing	31-61100A1	1
18-2743	Drive Shaft Housing to Bell Housing Gasket	27-94996-2	1

**18-2259
UPPER GEAR KIT**
Replaces: 43-803101T1
120/140 (1.98:1 Ratio)



**18-2125
YOKE**
Replaces: 39384, 46020, 460201, 46020T, 4602002, 46020002
Fits all #1/ALPHA Units (S/N 1684188 - OK999999)



**18-2146
YOKE**
Replaces: 20175, 59830A1, 59830A7
Fits all #1, R, MR, Alpha I, Alpha I Gen II, Bravo & Blackhawk



**18-6400
YOKE**
Replaces: 12784, 12784T
For: Bravo (OM111207 & below) and Blackhawk



**18-6401
YOKE ASSEMBLY**
Replaces: 12784A10, 12784A4
For: Bravo I, II, III (OB664190 - up) (1998-05)



**18-9218
YOKE ASSEMBLY**
Replaces: 814819A2, 59830A5, 59829A1
For all #1, R/MR/ALPHA Gen II
OK999999 & Below (1971-97)



**18-2128
CENTER SOCKET**
Replaces: 39383, 39383T, 393831 (Rockwell)
Fits IA/IB/IC & EZ, MC-I, R, MR, Alpha One, Gen II (OL949778 & below), Bravo (OM111207 & below), MC II & TS



**18-6404
CENTER SOCKET**
Replaces: 865503T
Fits: Alpha I Gen II OL949779 & UP, (GKN style)



**18-1711
U-JOINT**
Replaces: 862132, 862132T
For: Bravo One, Two, & Three (All Ratios), Bravo One X/Two X, Three X (All Ratios), Bravo One XR/XZ (All Ratios), Bravo One XR Sportmaster (All Ratios) & Integrated Transom



**18-2097
U-JOINT**
Permalube
Replaces: 8055361, 805536A1, 805536A2
For: Generation II F680000 & UP

 <p>18-2104 U-JOINT Heavy Duty Replaces: 75832, 75832A2, 75832T, 758321, 75832T1, 75832A1, 75832A3, 58749, 41431, 36312 Includes both straight and 90° grease fitting. Fits all #1 and ALPHA I Units S/N 1684188-B418818. Also TR/TRS and II SSM.</p>	 <p>18-2174 U-JOINT Heavy Duty Replaces: 36312, 41431, 58749, 75832, 75832T, 75832A1, 75832A2, 75832A3, 758321, 75832T1 Includes both straight and 90° grease fitting. Fits ALPHA I Units S/N B418819 & above. Also fits ALPHA I SS & BRAVO</p>	 <p>18-6406 U-JOINT ASSEMBLY Replaces: 865496A01, 865493A01, 865510T, 865496A01, 865511T GKN new style with external clips. Fits: Alpha I Gen II 0L949779 & UP, Bravo 0M11208 & UP For: Mercruiser Vazer</p>	 <p>18-8311 GIMBAL HOUSING REBUILD KIT Fits: Alpha One</p>
 <p>18-8312 GIMBAL HOUSING REBUILD KIT Fits: Gen II</p>	 <p>18-8313 GIMBAL HOUSING REBUILD KIT Fits: Bravo</p>	 <p>18-21001 GIMBAL BEARING Replaces: 30-60794A2, 30-60794A4, 30-879194A02 Non Greasable Fits: MC-1, R, MR and Alpha(1974-97), Gen II(1991-97), Bravo I/II/III (1988-95)</p>	 <p>18-21006 GIMBAL BEARING Non Greasable Replaces: 30-862540T1, 30-862540A3, 30-862540A4, 30-879194A01 Fits: Gen II (1998-10), Bravo I/II/III & X/XR/XZ (1996-10)</p>
 <p>18-21005 GIMBAL BEARING Replaces: 30-862540A3, 30-862540T1, 30-862540A04, 30-879194A01 Greasable Fits: All Bravos, Alpha One Gen II (1998-up)</p>	 <p>18-21005K SEAL & GIMBAL BEARING KIT Replaces: 30-862540A3, 30-862540T1, 30-862540A04, 30-879194A01 Greasable Contains (1) each of 18-2094 & 18-21005 Fits: Gen II (1998-Up) and all Bravo</p>	 <p>18-2101 GIMBAL BEARING Replaces: 30-36418, 30-36056, 36147 Greasable (Link-Belt)</p>	 <p>18-2100 HEAVY DUTY GIMBAL BEARING Replaces: 30-60794A4, 30-60794A2, 30-879194A02 Greasable (Link Belt) Fits: Mercruiser- 120HP / 140HP (2791957-6225576) (With Gimbal Trim Sender), 165HP (2763442 & Up), 225S (3856268-4200499), 228HP (4782330 & Up), 233HP (4200500 & Up), 250HP (4791300 & Up)</p>
 <p>18-2100K SEAL & GIMBAL BEARING KIT Replaces: 30-60794A2, 30-60794A4, 30-879194A02 Greasable Contains (1) each of 18-2094 & 18-2100 Fits: 1, R, MR and Alpha (1974-97)</p>	 <p>18-73131 SWIVEL GIMBAL RING SHAFT Replaces: 98230A1 Fits: Mercruiser Alpha/Gen II/Bravo I/II/III & Vazer</p>	 <p>18-1705 HINGE PIN Replaces: 77123, 77123A1, 65547 (with grease port)For gimbal housing Fits: Alpha, Alpha Gen II S/N 0M815638 & Lower</p>	 <p>18-1706 HINGE PIN Replaces: 10-86801 For gimbal housing Fits: Alpha Gen II S/N 0M85639 & UP Bravo All Models with trim sender</p>

GIMBAL BEARING APPLICATION

Model	Year Range	Serial No. Range	Gimbal Bearing	Model	Year Range	Serial No. Range	Gimbal Bearing
I	1963	1534570-1684187	30-32537T	250 / 260	1977-1982	1791300-6225576	18-21001
IA	1964	1684188-1777798	18-2101	R / MR / ALPHA I	1983-1990	6225577 & UP	18-21001
IB	1964	1684188-1777798	18-2101	ALPHA I SS	1986-1989	A545004 & UP	18-21001
IC	1964	1684188-1777798	18-2101	ALPHA I GEN II	1991-1997	D469859-K999999	18-21001
EZ-SHIFT	1964	1684188-1777798	18-2101	ALPHA I GEN II	1998-2010	L100040 & UP	18-21001
120 / 140	1967-1973	2062141-3780849	18-2101	BRAVO I	1988-1995	B664190-F729999	18-21001
120 / 140	1974-1982	3780850-6225576	18-21001	BRAVO II	1988-1995	B664190-F729999	18-21001
470 / 485	1976-1982	4208730-6225575	18-21001	BRAVO III	1988-1995	B664190-F729999	18-21001
160 / 165	1967-1973	2065190-3780849	18-2101	BRAVO I	1996-2010	F730000 & UP	18-21006
165	1974-1981	3780850 & UP	18-21001	BRAVO II	1996-2010	F730000 & UP	18-21006
888	1971-1973	3106717-3784374	18-2101	BRAVO III	1996-2010	F730000 & UP	18-21006
888	1974-1977	3784375 & UP	18-21001	X / XR / XZ	1996-2010	F730000 & UP	18-21006
225 / 233	1974	3856268 & UP	18-21001	BLACKHAWK	1994-1995	F186717 & UP	18-21001
898 / 228	1977-1982	4782330-6225576	18-21001	II	1964-1969	1602186-2671321	18-2101



18-2381
UPPER DRIVE UNIT CAP
 Replaces: 94998A1, 94998A2,
 94998A3, 94998A4
 S/N 6225577 & Later Alpha I, except Gen II



18-2382
UPPER DRIVE UNIT CAP
 Replaces: 828692A1, 18312A3
 For: Gen II S/N F680000 & UP



18-3752
RETAINING NUT
 Replaces: 8168111, 8168112,
 66071, 35992



18-4296
SPACER RING
 Replaces: 35983
 (Upper Housing)



18-0577
CARRIER OIL SEAL ASSEMBLY
 Replaces: 66081A2, 35993A1,
 66081A1, 66081A4



18-3219
WATER TUBE & COVER ASSEMBLY
 Replaces: 32489, 32489A2, 42724A3
 For: Merc I and Alpha I drives
 Models: I, 1A, 1B, 1C, 1CEZ, 120, 140, 160,
 165, 888, 898, 228, 225-S, 233, 250, 260,
 470, 485, R, MR, Alpha
18-3229 Bolt Replaces: 10-28668



18-2322
SHIFT SHAFT
 Replaces: 62104, 621041
 For: I and Alpha I



18-2169
SHIFT ARM
 Replaces: 45589A1, 45589A3



18-3749
UPPER SHIFT SHAFT
 Replaces: 816685
 For: Alpha Gen II (1991-98)

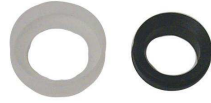

18-2599
FACE SEAL & TOOL
 Replaces: 26-816575A2
 For: ALPHA I GENERATION II



18-2622
BELL HOUSING BUSHING KIT
 Replaces: 23-79373A1,
 23-805041A2, 27-45588, 27-79373



18-3760
BELL HOUSING BUSHING KIT
 Replaces: 23-806036A1
 For: GEN II Serial # F680000 & UP



18-2179
DRIVE SHAFT
 Replaces: 45-55796



18-2324
DRIVE SHAFT
 Replaces: 45-557961
 For: Gen II (S/N F680000 & UP),
 Mercuriser Vazer



18-3713
LOCK NUT
 Replaces: 11-22339, 11-97522,
 11-36084, F1348, F1881
 $\frac{5}{8}$ " - 18



18-3712
CARRIER NUT WASHER
 Replaces: 12-45810



18-2161
SHIFT ARM
 Replaces: 45518A1, 45518A2,
 45518A3



18-2170
SHIFT ARM SCREW
 Replaces: 10-45590,
 10-8M0084649



18-2162
SHIFT CABLE SLIDE & SCREW
 Replaces: 33981, 33981T,
 33981T1, 8507521, 8507522



18-2162E
SHIFT CABLE SLIDE & SCREW
 Replaces: 33981, 33981T1,
 8507521, 8507522
 For: Extreme Cables Only

PKG. OF 5



18-2163
18-2163-9①
SHIFT SLIDE SCREW
 Replaces: Mercuriser 10-31700
 GLM: 21090
 Mallory: 9-72152

PKG. OF 5 **XTREME**



18-2163E-9①
SHIFT SLIDE SCREW
 For: Extreme Cables Only



18-2715
CHECK VALVE KIT
 Replaces: 24-17997A1
 For: Alpha I Generation II and Bravo I, II, and III Drives



18-2724
TRANSOM SEAL
 Replaces: 3713
 For: Alpha Gen II, All Bravo

— CONTAINS —

Part #	Description	O.E. #	Qty.
18-2619-1	Outdrive Gasket Set	27-64818A3 27-94996A1,Q2	1
18-2100	Gimbal Bearing	30-60794A2, 30-60794A4	1
18-2161	Shift Arm	45518A2	1
18-2751	U-Joint Bellows	60932A4	1
18-2750	Exhaust Bellows	32734A3, 18654A1	1
18-2753-1	Shift Cable Bellows	74639	1
18-3601	Water Intake Hose	32-32461	1
18-3602	Water Intake Hose	32-41725-33	1
18-710-16-2	Hose Clamp	—	2
18-7314	Stainless Steel Hose Clamp	—	1
18-710-64-2	Stainless Steel Hose Clamp	—	1



18-2601-1
TRANSOM SEAL KIT
 Replaces: 30-803097T1
 R, MR, ALPHA 1 (1983-90) S/N 6225577 & UP
 ALPHA 1 SS (1986-89) S/N OA 545004 & UP
 *Greasable Gimbal Bearing

— CONTAINS —

Part #	Description	O.E. #	Qty.
18-2100	Gimbal Bearing	30-60794A4, 30-60794A2	1
18-2751	U-Joint Bellows	60932A4	1
18-2760	Exhaust Tube	78458A1	1
18-3601	Water Intake Hose	32-32461	1
18-3602	Water Intake Hose	32-41725-33	1
18-2743	Drive Shaft Housing to Bell Housing Gasket	27-94996-2	1
18-2840	Bell Housing Gasket	27-35982	1
18-7153	O-Ring	25-25439	1
18-7117	O-Ring	25-35027	1
18-710-16-2	Hose Clamp	—	2
18-7170	O-Ring	25-33504	1
18-710-24-2	Hose Clamp	—	1
18-2753-1	Shift Cable Bellows	74639	1
18-7321	Bellows Clamp	54-38863	1



18-8205
TRANSOM SEAL KIT
 Replaces: 30-803098T1
 For: 1, R, MR, Alpha 1 with exhaust tube
 *Greasable Gimbal Bearing

— CONTAINS —

Part #	Description	O.E. #	Qty.
18-3602	Water Intake Hose	32-41725-33	1
18-710-16-2	Hose Clamp	—	2
18-710-24-2	Hose Clamp	—	1
18-2753-1	Shift Cable Bellows	74639	1
18-7321	Bellows Clamp	54-38863	1
18-2100	Gimbal Bearing	30-60794A4, 30-60794A2	1
18-2743	Drive Shaft Housing to Bell Housing Gasket	27-94996-2	1
18-2840	Bell Housing Gasket	27-35982	1
18-7153	O-Ring	25-25439	1
18-7170	O-Ring	25-33504	1
18-7117	O-Ring	25-35027	1
18-2750	Exhaust Bellows	18654A1, 32734A3	1
18-2747	Drive Bellows	816431A1	1



18-8206-1
TRANSOM SEAL KIT
 Replaces: 30-803099T1
 For: Alpha 1 Gen II
 *Greasable Gimbal Bearing

— CONTAINS —

Part #	Description	O.E. #	Qty.
18-2753-1	Shift Cable Bellow	74639	1
18-2100	Gimbal Bearing	30-862540A3	1
18-2756	U-Joint Bellows	86840A3	1
18-2750	Exhaust Bellows	32734A3	1
18-2760	Exhaust Tube	78458A1	1
18-3603	Water Hose	32-43437	1
18-2615	Outdrive Mounting Kit	16755A1	1



18-8212-1
TRANSOM SEAL KIT
 Replaces: 30-803100T1, 8M0095485
 For: All Bravos 1982 & up
 *Greasable Gimbal Bearing

① Priced per Package



18-8213
TRANSOM SEAL KIT
Replaces: 30-803097T1
For: R, MR, Alpha 1 (1983-90) S/N 6225577-0D469858; Alpha 1 SS (1986-89) S/N 0A545004 & Up
 *Sealed Gimbal Bearing **18-21001**



18-8217
TRANSOM SEAL KIT
Replaces: 30-803098T1
For: R, MR, Alpha 1 (1983-90) w/exhaust tube S/N 6225577-0D469858; Alpha 1 SS (1986-89) w/exhaust tube S/N 0A545004 & Up
 *Sealed Gimbal Bearing **18-21001**



18-8218
TRANSOM SEAL KIT
Replaces: 30-803099T1
For: Alpha 1 Gen II (1991 & Up) S/N 0D469859 & Up
 *Sealed Gimbal Bearing **18-21006**



18-8219
TRANSOM SEAL KIT
Replaces: 30-803100T1
For: Bravo I/II/III (1988 & Up) S/N 0B664190 & Up; Blackhawk (1994-95) S/N 0F186717 & Up
 *Sealed Gimbal Bearing **18-21006**



18-2747
U-JOINT BELLOWS
 Alpha 1, Gen II
Replaces: 816431A1



18-2750
EXHAUST BELLOWS
 All #1 Units, Gen II, TRS, & Bravo I, II, III
Replaces: 32734, 32734A3, 18654A1
 (Includes **18-710-48-2** Clamp)



18-2751
U-JOINT BELLOWS
 All #1 units with ridge
 (S/N 3469428 & UP)
Replaces: 60932A1, 60932A4
 (Includes **18-710-72-2** Clamp)



18-2752
U-JOINT BELLOWS
 All #1 units without ridge
 (S/N 3443920 & BELOW)
Replaces: 36223, 36223A1, 36223A2
 (Includes **18-710-72-2** Clamp)



18-2753-2
SHIFT CABLE BELLOWS
 All #1, #2 units, Alpha, Bravo I, II, III
Replaces: 31659, 74639, 74639A2
 (Includes **18-7321** Clamp)



18-2756
U-JOINT BELLOWS
Replaces: 86840A3, 86840A05, 8M0062406
Fits: All Bravo and Blackhawk models



18-1710
BELLOW FLANGE RING
Replaces: 862209, 86814
Fits: All Bravo



18-1728
BELLOW FLANGE RING
Replaces: 816607
Fits: Alpha One (GenII) (1991 and Up)



18-2746
EXHAUST BOOT
Replaces: 32-14358, 32-14358T, 31-14358001
 (4" Lower Tube)



18-2748
EXHAUST BOOT
Replaces: 32-44348, 32-44348T, 31-44348001
 (4" Upper Tube)



18-2759
EXHAUST TUBE
Replaces: 53114, 53114A1



18-2760
EXHAUST TUBE
Replaces: 78458, 78458A1
 (Includes **18-7314** Clamp)
For: #1, Bravo I, II, III



18-2761
EXHAUST TUBE
 3" I.D.
Replaces: 32-90949, 32-90949T



18-2762
EXHAUST TUBE
Replaces: 70981, 70981A3











18-2770
EXHAUST TUBE
Replaces: 32-807458T

① Items ending in "D" are Display Packaged - Regular number is Non-Display

BELLOWS APPLICATION

Model	Years	Serial #	Exhaust Bellows	Shift Cable Bellows	U-Joint
I/1A/1B/1C & EZ	1963-1966	1534570-2065186	18-2750	18-2753-2	18-2752
120/140/160/165	1967-1972	2062141-3443920	18-2750	18-2753-2	18-2752
120/140/160/165	1972-1982	3469428-6225576	18-2750	18-2753-2	18-2751
888	1971-1972	3106717-3472477	18-2750	18-2753-2	18-2752
888	1973-1977	3472478 & Up	18-2750	18-2753-2	18-2751
225/233	1974-1977	3856268 & Up	18-2750	18-2753-2	18-2751
898/228/250/260	1977-1982	4782330-6225576	18-2750	18-2753-2	18-2751
R/MR/Alpha One	1983-1990	6225577 & Up	18-2750	18-2753-2	18-2751
R/MR/Alpha One	1983-1990	6225577 & Up	18-2760 ②	18-2753-2	18-2751
Alpha One Gen II	1991 & Newer	0D469859 & Up	18-2750	18-2753-2	18-2747
Bravo I/II/III	1988 & Newer	0B664190 & Up	18-2750	18-2753-2	18-2756
Bravo I/II/III	1988 & Newer	0B664190 & Up	18-2760 ②	18-2753-2	18-2756
Blackhawk	1994-1995	0F18677 & Up	18-2750	18-2753-2	18-2756
Blackhawk	1994-1995	0F18677 & Up	18-2760 ②	18-2753-2	18-2756
II	1962-1969	1474909-2671321	—	18-2753-2	—
215H	1970	2782203-2909034	—	—	18-2752
215E	1970-1972	2909035-2915034	—	18-2753-2	18-2752
TR/TRS	1973-1993	3377316 & Up	—	—	18-2751

② Tube

<p>PKG. OF 5</p>  <p>18-7321 18-7321-9② BELLOWS CLAMP Replaces: 54-38863, 54-866507, 54-8M0090424</p>	<p>18-2159 INNER SHIFT CABLE Replaces: 19543A2, 19543A4, 19543A8, 19543A10, 41951A1, 66065A1, 66069A2, 73679A2, 865436A02 Use in 18-2157, 18-2158 and their MerCruiser equivalent as replacement wire and tube Stranded Core 73" 18-2189 Replaces: 32992A1, 34086A1, 37611A1, 38399A2 Use with 18-2248 Inner Core Wire 59"</p> 
<p>18-2160 SHIFT CABLE SUPPORT TUBE Replaces: 32-38377 Replaces tube on 18-2157, 18-2158 & 18-2159</p> 	<p>18-2248 SHIFT CABLE ASSEMBLY Replaces: 73723A1, 73723A01, 49518A1, 35187A1, 35187A2, 35187A4 MerCruiser #1 Drives S/N 1562900-6225576 for forward installation into bell housing. Has new style armored strand construction. (No support tube) 54" conduit with hardware package.</p> 
<p>18-2157 Replaces: 19543A2, 41951A1, 19543A8, 19543A10, 19543A4, 66065A1, 66069A2, 73679A2, 865436A02 MerCruiser 1 drives S/N 6225577 & UP For AFT installation into bell housing. Has old style stranded core wire with soldered tip (Uses Support Tube). 18-2158 MerCruiser #1 Drives S/N 1562900-6225576 for forward installation into bell housing. Has old style stranded core wire with soldered tip. (Uses support tube 18-2160) 63" conduit</p>  <p>SHIFT CABLE ASSEMBLY</p>	<p>18-2190 SHIFT CABLE Replaces: 19543A2, 19543A4, 19543A8, 19543A10, 41951A1, 66065A1, 66069A2, 73679A2, 865436A02 MerCruiser 1 drives S/N 6225577 & UP For AFT installation into bell housing. For use in applications using core wire with armored strand construction (No Support Tube). 63" Conduit with hardware package.</p> 
<p>18-2190E SHIFT CABLE Replaces: 19543A4, 19543A10, 19543A8, 19543A2, 41951A1, 66065A1, 66069A2, 73679A2, 865436A02 S/N 6225577 & UP. For AFT installation into bell housing. For use in applications using core wire with armored strand construction (No Support Tube). 63" Conduit with hardware package. Lower Shift Cable- Alpha One (Gen II) (1991-97) Requires 18-9806E (Xtreme Shift Cable Tool) to complete installation</p> 	<p>18-2145 SHIFT CABLE Replaces: 815471A3, 815471A6, 85147A5, 865437A02, 43432A2, 19297A3</p> 



18-2145E
SHIFT CABLE

Replaces: 815471, A3, A6
Bravo One, Two, & Three (All Ratios), Bravo One X/Two X, Three X (All Ratios), Bravo One XR/XZ(All Ratios), Bravo One XR Sportmaster (All Ratios) & Integrated Transom



18-9806E
SHIFT CABLE TOOL

Installs and removes shift cables on MC-I, R-MR, Alpha I, Alpha I Gen II drive units. Use with **18-2190** and **18-2190E** cables.



18-2149
SHIFT CABLE GUIDE

Replaces: 22879, 29880, 43433
For: Alpha & Bravo cables

PKG OF 25



18-2303
18-2303-9①
ANCHOR SCREW SET

Replaces: 10-20518
For: #1R, MR, Alpha, Alpha I, Gen II & Bravo



18-3754
CABLE ANCHOR

Replaces: 43436
For: #1R, MR, Alpha, Alpha I, Gen II & Bravo

18-2600
LOWER SHIFT CABLE KIT

— CONTAINS —

Part #	Description	O.E. #	Qty.
18-2753-2	Shift Cable Bellows	74639	1
18-2248	Shift Cable Assembly	73723A1	1
18-2162	Shift Slide & Screw	33981T	1
18-2149	Shift Cable End Kit	43433	1
18-2163	Shift Slide Screw	10-31700	1
18-2743	Drive Shaft Housing to Bell Housing Gasket	27-94996-2	1
18-2820	Drive Shaft Housing to Bell Housing Gasket	27-64818	1
18-2840	Bell Housing Gasket	27-35982	1
18-7117	O-Ring	25-35027	1
18-7153	O-Ring	25-25439	2
18-7170	O-Ring	25-33504	1



18-2603
LOWER SHIFT CABLE KIT

Replaces: 19543T1, 19543T2, 865436A03
ALPHA I GENERATION II

— CONTAINS —

Part #	Description	O.E. #	Qty.
18-2619-1	Outdrive Gasket Set	27-94996A1	1
18-2753-2	Shift Cable Bellows	74639	1
18-2190	Shift Cable Assembly	19543A4	1
18-2743	Drive Shaft Housing to Bell Housing Gasket	27-94996-2	1



18-2603E
LOWER SHIFT CABLE KIT (XTREME)

Replaces: 19543T1, 19543T2, 865436A03
For: Alpha I Gen II
Uses **18-2190E** shift cable.
Requires **18-9806E** (Xtreme Shift Cable Tool) to complete installation



18-2604
LOWER SHIFT CABLE KIT

Replaces: 815471T1
BRAVO

— CONTAINS —

Part #	Description	O.E. #	Qty.
18-2145	Bravo Shift Cable	815471A3	1
18-2149	Shift Cable End Kit	43433	1
18-2753-1	Shift Cable Bellows	74639	1
18-2615	Outdrive Gasket Set	—	1



18-2604E
LOWER SHIFT CABLE KIT (XTREME)

Replaces: 815471T1
Uses **18-2145E** shift cable.
For: Bravo

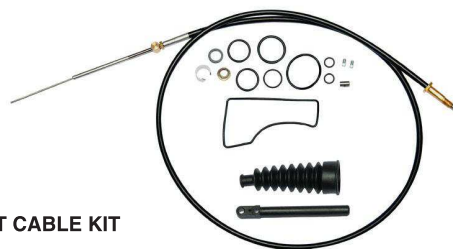

**GRADE 316
STAINLESS STEEL WORM GEAR
HOSE CLAMPS**



All components are manufactured from Marine Grade 316 stainless steel. These clamps are designed to fit many applications from 5/16" to 7" diameter hoses.

STAINLESS STEEL CLAMPS

Part #	O.E. #	Diameter Size	Std. #	Part #	O.E. #	Diameter Size	Std. #
18-710-06-2	-	7/16" to 3/4"	006	18-710-32-2	-	1 9/16" to 2 1/2"	032
18-710-10-2	-	9/16" to 1 1/16"	010	18-710-48-2 ①②	54-815504348	2 9/16" to 3 1/2"	048
18-710-12-2	-	9/16" to 1 1/4"	012	18-710-64-2 ①	-	2 1/2" to 4 1/2"	064
18-710-16-2	-	1 1/16" to 1 1/2"	016	18-710-72-2 ①③	-	3" to 5"	072
18-710-20-2	-	3/4" to 1 3/4"	020	18-710-104-2	-	5" to 7"	104
18-710-24-2	-	1 1/16" to 2"	024				

① For use with 3" Bellows ② O.E. #54-32533 ③ O.E. #'s 54-31765, 54-815504372

**18-2175
ENGINE
COUPLER**

Replaces: 12632A4
Uses **18-2146** Yoke Shaft
Flex plate style for late model, small crankshaft bolt pattern, style engines



**18-2195
ENGINE COUPLER**

Replaces: 12632A3, 12632A7
Uses **18-2146** Yoke Shaft
Flex plate style for GM 4 Cyl engines with late style, small crankshaft bolt pattern



**18-2323
ENGINE COUPLER**

Replaces: 18643A5
(Same as **18-2175** without yoke)



**18-2321
ENGINE COUPLER**

Replaces: 12632A6
(Same as **18-2195** without yoke)
For: Late model GM 4 cylinder



**18-2412-1
ENGINE
COUPLER**

Replaces: 18309A2, 18311A2, 18311A17,
812964A2, 861523A9, 8M0098795
For: Bravo



**18-2413
ENGINE
COUPLER**

Replaces: 69354A1, 69354A2
For: 470, 485 (224 cu. in.)
S/N 4208730-6218036 (1976-1982)



**18-2414
ENGINE
COUPLER**

Replaces: 97432A2
For: 165, 170, 470, 3.7L S/N 6170297 & UP (1983-1989)
180, 190, 488, 3.7LX S/N 6170297 & UP (1983-1989)



**18-2171
ENGINE
COUPLER**

Replaces: 32492A2, 32492A3, 32492A5,
38965A1, 38965A2, 76850A2
For: All GM engines except MR/ALPHA/BRAVO
with "Triangular", 3-Bolt coupler



**18-2172
ENGINE COUPLER**

Replaces: 14505A2
Used when replacing V6 or V8 2 piece rear main seal
with 3-1/2" crankshaft bolt pattern to a newer 1 piece
rear main seal engine with 3" bolt pattern



**18-2173
ENGINE
COUPLER**

Replaces: 59826A1, 59826A3
For: Ford engines



① Priced per Package

ENGINE COUPLER APPLICATION

HP	Liter	Model	CID	# Cyl	Stroke	Years	Serial #	Part #
110		110	153	4		1963-1966	1537370 - 2044033	18-2171
120		120	153	4		1964-1982	1537370 - 6229717	18-2171
120		120	153	4	4	1964-1982	1666601 - 6229717	18-2171
120		120	153	4	4	1983-1986	6229718 - B531853	18-2171 ①
120		120	153	4	4	1983-1986	6229718 - B531853	18-2195 ②
	2.5L	2.5L	153	4	4	1987-1989	B531854 - C853255	18-2171 ③
	2.5L	2.5L	153	4	4	1987-1989	B531854 - C853256	18-2195 ④
140		140	181	4	4	1968-1982	2508261 - 6229717	18-2171
140		140	181	4	4	1983-1986	6229718 - B450800	18-2171 ⑤
140		140	181	4	4	1983-1986	6229718 - B450800	18-2195 ⑥
140		140 INLINE 6		6	4	1963	1538930 - 1725960	18-2171
	3.0L	3.0L	181	4	4	1987-1989	B450801 - C856558	18-2171 ⑦
	3.0L	3.0L	181	4	4	1987-1989	B450801 - C856558	18-2195 ⑧
	3.0L	3.0L	181	4	4	1990-1994	C856559 - F603999	18-2195
	3.0L	3.0L	181	4	4	1998-2010	L097000 & UP	18-2323
	3.0L	3.0L MPI	181	4	4	2008-2010	A072812 & UP	18-2323
	3.0L	3.0LX	181	4	4	1990-1993	C856559 - F000000	18-2195
	3.0L	3.0LX	181	4	4	1994-1998	F000001 - L096999	18-2321
150		150			4	1964-1966	1666495 - 2048046	18-2171
160		160			4	1967-1969	2048022 - 2770031	18-2171
165		165	224	4	4	1987	B434941 - B774251	18-2414
165		165 INLINE 6		6	4	1970-1981	2770032 - 5813433	18-2171
170		170	224	4	4	1985-1986	6916779 - B434940	18-2414
180		180	224	4	4	1987	B436391 - B775248	18-2414
190		190	224	4	4	1985-1987	6916779 - B775248	18-2414
	3.7L	3.7L	224	4	4	1988-1989	B774252 & UP	18-2414
	3.7L	3.7LX	224	4	4	1983-1989	B775249 & UP	18-2414
		470	224	4	4	1976-1982	4208730 - 6218036	18-2413
		470	224	4	4	1983-1984	6218037 - 6916779	18-2414
		485	224	4	4	1980-1982	5685394 - 6218036	18-2413
		488	224	4	4	1983-1984	6170297 - 6916779	18-2414
		140	194	6	4	1963	1538930 - 1664117	18-2171
		150	230	6	4	1964-1966	1664118 - 2048046	18-2171
		160	250	6	4	1967-1969	2048022 - 2770031	18-2171
		165	250	6	4	1970-1981	2770032 - 5813433	18-2171
175		175			4	1987	B527955 - B773242	18-2175
185		185 (4bbl)	229	6	4	1983-1984	6330183 - 6919655	18-2171
175		175	262	V-6	4	1987	B527955 - B773242	18-2175
185		185 (2bbl)	262	6	4	1985-1986	A331455 - B527954	18-2171 ⑨
185		185 (2bbl)	262	6	4	1985-1986	A331455 - B527954	18-2175 ⑩
205		205	262	6	4	1985-1986	A331455 - B527954	21-2171 ⑪
205		205	262	6	4	1985-1986	A331455 - B527954	18-2175 ⑫
205		205	262	6	4	1987	B527995 - B775129	18-2175
		262 MAG EFI GEN+	262	V-6	4	1996-1997	F803800 - K999999	18-2323
	4.3L	4.3L	262	V-6	4	1988-1993	B527955 - F000877	18-2175
	4.3L	4.3L	262	V-6	4	1993-2010	F000878 & UP	18-2323
	4.3L	4.3L EFI GEN +	262	V-6	4	1998-2001	L012009 - M299999	18-2323
	4.3L	4.3L MPI	262	V-6	4	2002-2010	M300000 & UP	18-2323
	4.3L	4.3LH GEN +	262	V-6	4	1998-2002	L010044 - M614999	18-2323
	4.3L	4.3LX	262	V-6	4	1988-1993	B775130 - F001219	18-2175
	4.3L	4.3LX (4bbl)	262	V-6	4	1993-1995	F001220 - F802999	18-2323
	4.3L	4.3LX GEN + (2bbl)	262	V-6	4	1996-1997	F803000 - K999999	18-2323
	4.3L	4.3LXH GEN +	262	V-6	4	1996-1997	F803000 - K999999	18-2323
	5.0L	225 (FORD)	302	V-8	4	1973-1974	3385721 - 4166999	18-2173 ⑬
	5.0L	888	302	V-8	4	1971-1977	3108723 - 4887829	18-2173

- ① Use with Borg Warner transmission
- ② Low speed / work application
- ③ Coupler mounts to flywheel
- ④ Use with Hurth transmission

- ⑤ Hydraulic shift only
- ⑥ I drive only
- ⑦ Round shape coupler
- ⑧ Standard Bravo applications

- ⑨ Coupler mounts to crankshaft
- ⑩ Triangular shape coupler
- ⑪ Use with Borg Warner 71/72 series in-line transmission
- ⑫ Use with Borg Warner 5000 or Hurth 630 transmission

ENGINE COUPLER APPLICATION

HP	Liter	Model	CID	# Cyl	Stroke	Years	Serial #	Part #
		190	283	V-8	4	1963-1964	1564539 - 1730903	18-2171
5.0L		200	305	V-8	4	1985-1986	6899058 - B525981	18-2171 ①
5.0L		200	305	V-8	4	1985-1986	6899058 - B525981	18-2175 ②
5.0L		200	305	V-8	4	1985-1987	6899058 - B774444	18-2175
5.0L		228	305	V-8	4	1977-1982	4765100 - 6218461	18-2171
5.0L		228	305	V-8	4	1977-1984	6218462 - 6899268	18-2171
5.0L		230	305	V-8	4	1985-1987	6899269 - B773739	18-2171 ①
5.0L		230	305	V-8	4	1985-1987	6899269 - B773739	18-2175 ②
5.0L		5.0L ALPHA	305	V-8	4	1988-1993	B774445 - F000000	18-2175
5.0L		5.0L ALPHA	305	V-8	4	1994-1995	F000001 - F600999	18-2323
5.0L		5.0L GEN+ ALPHA	305	V-8	4	1998-2010	L015751 & UP	18-2323
5.0L		5.0L GEN + BRAVO	305	V-8	4	1998-2010	L015751 & UP	18-2412-1 ③
5.0L		5.0L EFI ALPHA	305	V-8	4	1998-2001	L012052 - M299999	18-2323
5.0L		5.0L EFI BRAVO	305	V-8	4	1998-2001	L015751 - M299999	18-2412-1 ③
5.0L		5.0LX ALPHA	305	V-8	4	1988-1993	B773740-F000000	18-2175
5.0L		5.0LX ALPHA	305	V-8	4	1994-2007	F000001 & UP	18-2323
5.0L		5.0L MPI BRAVO	305	V-8	4	1998-2007	L015751 & UP	18-2412-1
5.0L		5.0L MPI ALPHA	305	V-8	4	2002-2010	M300000 & UP	18-2323
5.0L		5.0L MPI BRAVO	305	V-8	4	2002-2010	M300000 & UP	18-2412-1 ③
5.0L		5.0LX ALPHA	305	V-8	4	1988-1993	B773740 - F000000	18-2175
5.0L		5.0LX ALPHA	305	V-8	4	1994-1995	F000001 - F600999	18-2323
5.0L		898	305	V-8	4	1977-1985	4762210 - 6899057	18-2171
		225 (GM)	327	V-8	4	1963-1969	1539620 - 2694014	18-2171
		250	327	V-8	4	1977	4768000 - 4908849	18-2171
5.7L		260	350	V-8	4	1978-1982	4908850 - 6218461	18-2171
5.7L		260	350	V-8	4	1982-1986	6218462 - B525981	18-2171 ①
5.7L		260	350	V-8	4	1982-1987	6218462 - B773304	18-2175 ②
5.7L		260	350	V-8	4	1987	B525982 - B773304	18-2175
5.7L		300 TEMPEST ALPHA	350	V-8	4	1985-1986	6668677 - B430367	18-2171 ①
5.7L		300 TEMPEST ALPHA	350	V-8	4	1986	A434310 - B430367	18-2175 ②
5.7L		320 EFI	350	V-8	4	1987-1989	A543604 - C622418	18-2175
5.7L		350 MAG ALPHA	350	V-8	4	1986-1993	A635178 - F000000	18-2175
5.7L		350 MAG ALPHA	350	V-8	4	1993-1997	F000001 - K999999	18-2323
5.7L		350 MAG ALPHA EFI GEN +	350	V-8	4	1996-1997	F800300 - K999999	18-2323
5.7L		350 Mag MPI ALPHA	350	V-8	4	1998-2010	L010019 & UP	18-2323
5.7L		350 MAG MPI BRAVO	350	V-8	4	1998-2010	L010019 & UP	18-2412-1 ③
5.7L		350 MAG MPI HORIZON ALPHA	350	V-8	4	2002-2007	M300000 - A299999	18-2323
5.7L		350 MAG MPI HORIZON BRAVO	350	V-8	4	2002-2007	M300000 - A299999	18-2412-1 ③
5.7L		350 MAG MPI HORIZON ALPHA	350	V-8	4	1993-2007	F000001 & UP	18-2323
5.7L		HORIZON BRAVO	350	V-8	4	1999-2007	M300000 & UP	18-2412-1
5.7L		5.7L ALPHA	350	V-8	4	1988-1993	B773305-F000000	18-2175
5.7L		5.7L ALPHA	350	V-8	4	1993-2010	F000001 & UP	18-2323
5.7L		5.7L BRAVO	350	V-8	4	1988-2010	B773305 & UP	18-2412-1 ③
5.7L		5.7L EFI ALPHA	350	V-8	4	1995-2001	F225560 - M299999	18-2323
5.7L		5.7L EFI BRAVO	350	V-8	4	1998-2001	L010035 - M299999	18-2412-1 ③
5.7L		5.7LX EFI ALPHA	350	V-8	4	1996-1997	F752400 - K999999	18-2323
5.7L		5.7LX EFI ALPHA	350	V-8	4	1993-2007	F000001 & UP	18-2323
5.7L		5.7L EFI BRAVO	350	V-8	4	1998-2007	L010035 & UP	18-2412-1 ③
5.7L		233	351	V-8	4	1975-1977	4173000 - 4902304	18-2173
6.2L		377 MAG	377	V-8	4	2008-2010	A300000 & UP	18-2412-1 ③
6.2L		MX 6.2L MPI	377	V-8	4	2000-2007	L680003 - A299999	18-2412-1 ③
6.2L		MX 6.2L MPI	377	V-8	4	2000-2007	L680003 - A299999	N/A ④
6.2L		MX 6.2L MPI HORIZON	377	V-8	4	2002-2007	M300000 - A299999	18-2412-1 ③
7.4L		454 MAG ALPHA	454	V-8	4	1986-1988	A631894 - B785148	18-2175 ⑤

- ① Use with Borg Warner transmission
- ② Low speed / work application
- ③ Coupler mounts to flywheel
- ④ Use with Hurth transmission
- ⑤ Hydraulic shift only
- ⑥ I drive only
- ⑦ Round shape coupler
- ⑧ Standard Bravo applications
- ⑨ Coupler mounts to crankshaft
- ⑩ Triangular shape coupler
- ⑪ Use with Borg Warner 71/72 series in-line transmission
- ⑫ Use with Borg Warner 5000 or Hurth 630 transmission



18-4442
ENGINE ALIGNMENT TOOL
Replaces: 91-57797A3, 91-57797A2, 91-57797A1, 91-8M0067546, 91-48347, 91-37384
For use with all #1 units, MR, all Alpha & Bravo units



18-9803
SPANNER NUT WRENCH
Replaces: 91-36235, 91-17256

SIERRA HYDRO DEFENSE MARINE GREASE

18-9240-0
 (8 oz Tube)
Replaces:
 Mercury 92-802859A1



18-9240-1
 (14oz Cartridge)
Replaces:
 Mercury 92-802863A1

- Prohibits rust and corrosion.
- Prevents wear against the most extreme friction in marine applications.
- Will not break down in marine conditions.
- Contains PTFE for minimum wear and added friction protection.
- For use on prop shafts, trailer bearings, throttle and shift cables and linkage, swivel pins and more!



18-2200
LOWER UNIT GEAR SET
Replaces: 43-61027, 43-96084A4
 888 S/N 3106717 & UP #1 Units S/N 3469428 & UP Except, MR/ALPHA Units (which have no pre-load pin in the top of the drive shaft).



18-2410
FORWARD GEAR SET
Replaces: 43-96084A7, 43-96084A5
For: "R" drive



18-2360
PINION & FORWARD GEAR SET
Replaces: 43-828072A3, 43-878087A2
 13-21 Teeth



18-2206-1
LOWER UNIT GEAR SET
Replaces: 43-878087A2 + 43-828073A1, 43-828072A2
For: Alpha 1 Gen II (serial 0F680000 & Up)



18-2409
REVERSE GEAR
Replaces: 43-92320, 43-92320T
For: "R" drive (28 teeth)



18-2406
FORWARD GEAR SET
Replaces: 43-878087A2, 43-878072A3
For: MR/Alpha/Gen II lower S/N D469859 & UP

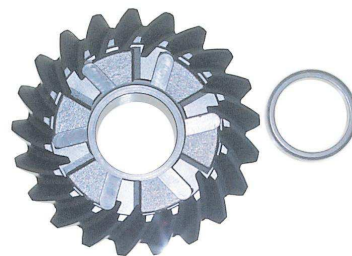

18-2408
REVERSE GEAR
Replaces: 43-828073A1
For: Alpha I/Gen II lower S/N D469859 & UP

18-2404
GEAR REPAIR KIT

Replaces: 43-803079T1
For: "R" drive

— CONTAINS —

Part #	Description	O.E. #	Qty.
18-2200	Lower Unit Gear Set	43-96084A4	1
18-2202	Sliding Clutch	52-66063	1
18-1157	Needle Roller Bearing	31-30895	1
18-1155	Ball Bearing	30-88957A1	1
18-1159	Tapered Roller Bearing	31-35928A1	1
18-2285	Shim	15-47397A1	1
18-3719	Pinion Nut	11-35921	1
18-2299	Tab Washer	14-79447	1



18-2405
GEAR REPAIR KIT

Replaces: 43-803091T1
For: MR/Alpha I

— CONTAINS —

Part #	Description	O.E. #	Qty.
18-2652	Lower Gear Housing Seal Kit	26-33144A2	1
18-3719	Pinion Nut	11-35921	1
18-2343	Washer	12-982721	1
18-2298	Tab Washer	14-18323	1
18-2299	Tab Washer	14-79447	1
18-2206-1	Gear Set	43-42934	1
18-2285	Shim	15-47397A1	1
18-1155	Ball Bearing	30-88957A1	1
18-1158	Needle Roller Bearing	31-30956	1
18-1117	Pinion Bearing	31-42647A1	1
18-1143	Alpha Bearing	31-36387A1	1
18-2294	Shim Kit	15-42637A-1	1
18-2202	Sliding Clutch	52-66063	1



18-2407
GEAR SET

Replaces:
43-878087A4, 43-823072A2, 43-42933A3,
43-42933A2, 43-17064A3
For: MR/Alpha/Gen II
lower gear housings

— CONTAINS —

Part #	Description	O.E. #	Qty.
18-2206-1	Gear Set	43-42934	1
18-1155	Ball Bearing	30-88957A1	1
18-1117	Pinion Bearing	31-42647A1	1
18-1158	Needle Roller Bearing	31-30956	1
18-1143	Alpha Bearing	31-36387A1	1
18-2294	Shim Kit	15-42637A-1	1
18-2285	Shim	15-47397	1
18-3719	Pinion Nut	11-35921	1
18-2343	Washer	12-982721	1

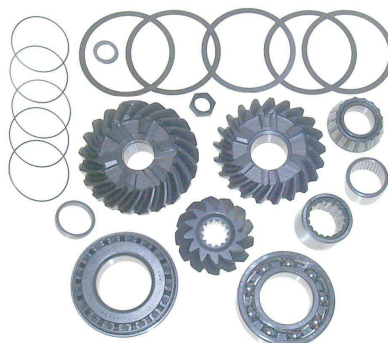

18-2202
SLIDING CLUTCH

Replaces: 52-66063, 52-853594T, 52-853594,
52-824112
888 S/N 3784375 & UP
#1 Units S/N 3469428 & UP



18-2357
CROSS PIN

Replaces:
17-30632, 17-8M0020941, 17-8M0100263,
17-8M0084681

PKG. OF 2



18-2348
18-2348-9^①
**CLUTCH CROSS
PIN SPRING**

Replaces: 24-30893
1/MC-1/R/MR/Alpha
Mercuriser/Gen II lower
S/N D469859-F679999
Mercuriser Vazer



18-2166
PROP SHAFT

Replaces: 44-66060, 44-660603, 44-824110, 44-660602, 44-55857
For: All #1 & MR/ALPHA Units S/N 2791957 & above.
Also for 165 (6 cyl.) S/N 2763442 & above.



18-2254
PROP SHAFT

Replaces: 44-850308
For: Alpha One Gen II S/N 0L100040 & up/Vazer

① Priced per Package



18-2180
DRIVE SHAFT

Replaces: 45-42634
For all MR/ALPHA Units & older units which have been retro-fitted with MR/ALPHA lower units.



18-2331
DRIVE SHAFT

Replaces: 45-853648, 45-853647
For: Ratios 1.47, 1.62, 1.81 & 1.94.
Fits: Gen II (1998 & up), (0L100040 & up)
For use with: 18-2400 Complete Lower Gear Case



18-2261
DRIVE SHAFT

Replaces: 45-816919
All Alpha I Generation II Drives (with new style 18-3056 Impeller)
Serial #D494569 & above.



18-2346
RETAINER NUT

Replaces: 824519, 8245191, 11-42633, F694961, F694961-1
For: MR Alpha & Gen II



18-3719
PINION NUT

Replaces: 11-35921, 11-47411,
11-826375, 11-F694188
5/8" - 18 thread • 1 1/16" wrench

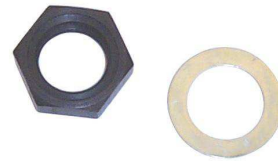

18-2359
DRIVE SHAFT NUT SET

— INCLUDES —

Sierra #	Description	Replaces:
18-3719	Pinion Nut	11-35921
18-2343	Pinion Nut Washer	12-92721



18-2286
Replaces: 66067, 66067T,
19755A2, 818349A1, 818349T1



18-2196
Replaces: 37967, 61073, 19755A4,
19755A08

SHIFT SPOOL ASSEMBLIES

SHIFT SPOOL ASSEMBLY APPLICATION

Model	Serial #	Part #
1A (EZ-Shift)	1776349 & UP	18-2196
1B (EZ-Shift)	1775193 & UP	18-2196
1C (EZ-Shift)	1777799 & UP	18-2196
120/140	2062141-3780849	18-2196
120/140	3780850 & UP	18-2286
160	2065190-2763441	18-2196
165	2763442-3780849	18-2196
165	3780850 & UP	18-2286
888	3106717-3784374	18-2196
888	3784375 & UP	18-2286
898/228	4782330 & UP	18-2286
225-S	3856268-4200499	18-2286
233	4200500 & UP	18-2286
470/485	4208730 & UP	18-2286
R/MR/Alpha One	6225377 & UP	18-2286
Alpha One (Gen II)	D494569 & UP	18-2286





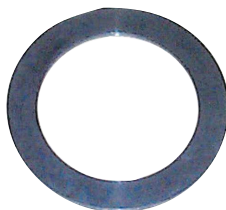







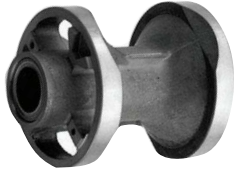



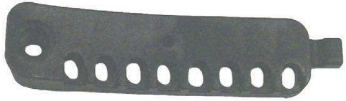

18-3759
THRUST BEARING RING
Replaces: 35915



18-2342
THRUST RING
Replaces: 68100, 681001
For: MR/ ALPHA



18-2191
CARRIER BEARING
Replaces: 56211A1, 73020A1, 73020A14
For: #1R/MR/Alpha I
For: Housings with casting #73020C

 <p>18-2376 CARRIER BEARING Replaces: 73020A20, 818763A4, 818763A10 For: Alpha Gen II & MR Units For: Housings with casting #73020C1, Mercruiser Vazer</p>	 <p>18-2150 SHIFT SHAFT Replaces: 37973, 65028, 66066, 77481, 774811 Stainless Steel</p>	 <p>18-2353 SHIFT ROD BUSHING ASSEMBLY Replaces: 23-815921A21, 23-815921A17, 23-815921A10, 23-815921A8, 23-815921A6, 815921A2</p>												
 <p>18-2154 SHIFT SHAFT HOUSING BUSHING Replaces: 23-30617A1, 23-30617A2 Mercruiser & Alpha 1 (S/N 1684188 & UP)</p>	 <p>18-3198 WATER PICK-UP (Port) Replaces: 93424, 934241, 934243 For: MR Alpha</p>	 <p>18-3199 WATER PICK-UP (Starboard) Replaces: 93423, 934231, 934233 For: MR Alpha</p>												
 <p>18-2320 SHIFT SHAFT Replaces: 815919A1 For: Gen II</p>	 <p>18-2130 SHIFT CRANK Replaces: 66062, 76865, 8M2009865 For: All #1 Units R/MR/Alpha, Mercruiser Vazer</p>	<p>PKG. OF 2</p>  <p>18-4295 18-4295-9① E-CLIP Replaces: 53-29641 For: Gen II</p>	 <p>18-2299 TAB WASHER Replaces: 14-79447, 14-52833</p>	 <p>18-2298 TAB WASHER Replaces: 14-18323, 14-17460</p>										
 <p>18-3751 SPANNER NUT Replaces: 79448 For: Mercruiser Vazer</p>	 <p>18-2354 CARRIER SEAL Replaces: 821759A4, 821759A3, 821759A2, 821759A1, 815922A5, 815922A1, 807929A2, 807929A1</p>	<p>PKG. OF 2</p>  <p>18-2707 18-2707-9① COLLAR KEEPER Replaces: 97351 For: Bravo</p>	 <p>18-1117 PINION BEARING Replaces: 31-42647A1</p>											
 <p>18-1120 PINION BEARING Replaces: 31-35246 For: Lower drive shaft III, TR & Bravo I, II, III (1986-95)</p>	 <p>18-1356 PINION BEARING Replaces: 31-54928</p> <table border="1"> <thead> <tr> <th>Model</th> <th>Year</th> <th>Model</th> <th>Year</th> </tr> </thead> <tbody> <tr> <td>215 EH</td> <td>1970-72</td> <td>II, TR</td> <td>1973-76</td> </tr> <tr> <td>225TRS, 280 TRS</td> <td>1973-76</td> <td>TR, TRS</td> <td>1977-93</td> </tr> </tbody> </table>	Model	Year	Model	Year	215 EH	1970-72	II, TR	1973-76	225TRS, 280 TRS	1973-76	TR, TRS	1977-93	 <p>18-1142 UPPER PINION BEARING Replaces: 31-32573A1</p>
Model	Year	Model	Year											
215 EH	1970-72	II, TR	1973-76											
225TRS, 280 TRS	1973-76	TR, TRS	1977-93											

① Priced per Package



18-1193
TAPERED
ROLLER BEARING
 Replaces: 31-33138A1
 Fits: Gen II (1998-Up), Mercuriser Vazer



18-1143
TAPERED
ROLLER BEARING
 Replaces: 31-36387A1



18-1156
FORWARD
GEAR BEARING
 Replaces: 31-30894A1
 For: Mercuriser Vazer



18-1161
TAPERED
ROLLER BEARING
 Replaces: 31-35990A1
 For: Mercuriser Vazer



18-1162
TAPERED
ROLLER BEARING
 Replaces: 31-38356A1, 31-F84901, FA84901,
 F84903



18-1165
TAPERED
ROLLER BEARING
 Replaces: 31-61100A1



18-1173
TAPERED
ROLLER BEARING
 Replaces: 31-828437A2



18-1179
TAPERED
ROLLER BEARING
 Replaces: 31-32575A1, T1
 For: Gen II F680000 & UP, Mercuriser Vazer



18-1126
TAPERED ROLLER
BEARING
 Replaces: 31-8M0103474



18-1127
TAPERED
ROLLER BEARING
 Replaces: 31-54038A1
 For: Bravo II - Lower (S/N B664190 & UP)



18-1163
TAPERED ROLLER
BEARING
 Replaces: 31-48941A1



18-1197
TAPERED FORWARD GEAR
BEARING
 Replaces: 31-828439A2
 For: Alpha One Gen II (1996-97)
 (s/n 0F680000-0K999999)



18-1182
ROLLER BEARING KIT
 Replaces: 31-30894A5
 For: Alpha I (Gen II) (1998 & up)
 (OL100040 & up), Mercuriser Vazer



18-1129
UPPER DRIVE
SHAFT BEARING
 Replaces: 31-86748A1,
 31-8M0103473, 31-F506818,
 F508814
 For: Bravo I, II, III - Lower
 (S/N B664190 & UP)



18-1150
NEEDLE ROLLER BEARING
 Replaces: 31-92366A1,
 31-92366



18-1180
NEEDLE BEARING
 Replaces: 31-54042T
 For: Bravo I, II, III (1988-98), TRS
 (1977-93)-carrier



18-1157
FORWARD GEAR
INNER BEARING
 Replaces: 31-30895, 31-30895T
 For: Mercuriser Vazer



MERCRUISER STERNDRIVE UPPER GEAR HOUSING BEARINGS

Sterndrive Model	Drive Ratio	Years	Serial #	Drive Gear (Yoke)	Driven Gear	Upper Cap
IA,IB,IC & EZ Shift	All	1964-66	1684188 - 2065186	18-1160	18-1161	18-1179
120/140	1.98	1967	2062141 - 2187468	18-1160	18-1161	18-1161
120/140	1.98	1967-71	2187469 - 3134193	18-1160	18-1161	18-1179
120/140	1.98	1971-82	3134194 - 6225576	18-1160	18-1161	18-1165
470/485	1.84	1976-82	4208730 - 6225576	18-1160	18-1161	18-1165
160	1.68	1967	2065190 - 2182197	18-1160	18-1161	18-1161
160	1.68	1967-71	2182198 - 3134193	18-1160	18-1161	18-1179
165	1.65	1971-81	3213658 - UP	18-1160	18-1161	18-1165
888	1.5	1971-73	3106717 - 3134193	18-1160	18-1161	—
888	1.5	1973-77	3134194 - UP	18-1160	18-1161	18-1165
225-S	1.5	1974	3856268 - 4200499	18-1160	18-1161	18-1165
898/228	1.65	1977-82	4782330 - 6225576	18-1160	18-1161	18-1165
233	1.32	1975-77	4200500 - UP	—	—	18-1165
250	1.32	1977	4791300 - 4898729	—	—	18-1165
255-TRS	All	1973-74	3377316 - 4203749	18-1162 ③	18-1162	—
260	1.5	1978-82	4898730 - 6225576	18-1160	18-1161	18-1165
280-TRS	All	1975-76	4203750 - 4895399	18-1162 ③	18-1162	—
R/MR/Alpha One	1.98/1.84/1.65/1.50	1984-90	6225577 - UP	18-1160	18-1161 ① ④	18-1165
R/MR/Alpha One	1.5	1984-90	6225577 - UP	18-1160	18-1142	18-1165
R/MR/Alpha One	1.32	1984-90	6225577 - UP	—	—	18-1165
R/MR/Alpha One	1.5 Heavy Duty	1984-90	6225577 - UP	—	18-1142	18-1165
Alpha One SS	1.32	1986-89	A545004 - UP	—	—	18-1165
Alpha One SS	1.5	1986-89	A545004 - UP	—	18-1142	18-1165
Alpha One Gen II	2.40/1.98/1.84/1.65	1991-95	D469859 - F679999	18-1160	18-1161 ④	18-1165
Alpha One Gen II	1.5	1991-95	D469859 - F679999	18-1160	18-1142	18-1165
Alpha One Gen II	2.40/1.94/1.81/1.62	1996-97	F680000 - K999999	18-1160	18-1161 ④	18-1179
Alpha One Gen II	1.47	1996-97	F680000 - K999999	18-1160	18-1142	18-1179
Alpha One Gen II	2.40/2.00/1.94/1.81/1.62	1998 & Up	L100040 - UP	—	18-1161	18-1179
Alpha One Gen II	1.47	1998 & Up	L100040 - UP	—	18-1142	18-1179
II-TR	—	1973-76	3377316 - 4794899	18-1162 ②	18-1162	—
SSM II	—	1982-97	ALL	18-1162 ③	18-1162	—
TR/TRS	—	1977-93	4794900 - UP	18-1162 ③	18-1162	—
Bravo I, II, III	All	—	B664190 & UP	—	—	18-1129

- ① Timken Cone # 89449 / Cup 89410
- ② Straight Shoulder Gear Only
- ③ Bearing for U-Joint Yoke
- ④ Use 18-1142 for 1.5:1 Upper Gear Ratio

MERCRUISER STERNDRIVE LOWER GEAR HOUSING BEARINGS

Sterndrive Model	Years	Beg. Serial # - End Serial #	Prop Bearing Carrier	Lower Drive Shaft (Pinion)	Upper Drive Shaft	Inside Forward Gear (Needle)	Outside Forward Gear	Reverse Gear
60	1965-66	1830753 - 2063740	—	—	—	—	18-1162	—
80/90	1966-72	2063741 - 3225967	18-1158	—	—	18-1157	18-1156	—
I	1963	1534570 - 1536617	18-1158	—	18-1153	18-1157	18-1156	—

- ① 18-1161 Top Bearing / 18-1163 Bottom Bearing
- ② Torrington#B1616
- ③ Prop Shaft Drive Gear
- ④ #15520 Stamped on Cup
- ⑤ Use 18-1173 for 2.40:1 ratio only (new style lower gears) our 18-2206-1

MERCURISER STERNDRIVE LOWER GEAR HOUSING BEARINGS (Cont.)

Sterndrive Model	Years	Beg. Serial # - End Serial #	Prop Bearing Carrier	Lower Drive Shaft (Pinion)	Upper Drive Shaft	Inside Forward Gear (Needle)	Outside Forward Gear	Reverse Gear
I	1963	1536618 - 1684187	18-1158	—	—	18-1157	18-1156	—
IA,IB,IC & EZ Shift	1964-66	1684188 - 2065189	18-1158	—	—	18-1157	18-1159	18-1155
120/140	1967-69	2062141 - 2791956	18-1158	—	—	18-1157	18-1159	18-1155
120/140	1970-77	2791957 - 4893634	18-1158	—	—	18-1157	18-1159	18-1155
120/140	1978-82	4893635 - 6225576	18-1158	18-1150	—	18-1157	18-1159	18-1155
470	1976-77	4208730 - 4893934	18-1158	—	—	18-1157	18-1159	18-1155
470/485	1978-82	4893835 - 6225576	18-1158	18-1150	—	18-1157	18-1159	18-1155
160	1967-69	2065190 - 2763441	18-1158	—	—	18-1157	18-1159	18-1155
165	1970-77	2763442 - 4890459	18-1158	—	—	18-1157	18-1159	18-1155
165	1978-81	4890460 - UP	18-1158	18-1150	—	18-1157	18-1159	18-1155
888	1971-77	3106717 - UP	18-1158	—	—	18-1157	18-1159	18-1155
225/233	1974-77	3856268 - UP	18-1158	—	—	18-1157	18-1159	18-1155
898/228	1977	4782330 - 4898729	18-1158	—	—	18-1157	18-1159	18-1155
898/228	1978-82	4898730 - 6225576	18-1158	18-1150	—	18-1157	18-1159	18-1155
250	1977	4791300 - 4898729	18-1158	—	—	18-1157	18-1159	18-1155
255-TRS	1973-74	3377316 - 4203749	18-1158	—	—	—	18-1159	N/A
260	1978-82	4898730 - 6225576	18-1158	18-1150	—	18-1157	18-1159	18-1155
280-TRS	1975-76	4203750 - 4895399	18-1158	—	—	—	18-1159	N/A
R	1983	6225577 - UP	18-1158	18-1150	—	18-1157	18-1159	18-1155
MR / Alpha One	1984-90	6225577 - UP	18-1158	18-1117	18-1143	—	18-1159 ⑤	18-1155
MR / Alpha One	1984-90	6225577 - UP	18-1158	18-1117	18-1143	18-1157 ②	18-1159 ⑤	18-1155
MR / Alpha One (CR)	1984-90	6225577 - UP	18-1158	18-1117	18-1143	—	—	—
Alpha One SS	1986-89	A545004 - UP	18-1158	18-1117	18-1143	18-1157	18-1159	18-1155
Alpha One Gen II	1991-95	D469859 - F679999	18-1158	18-1117	18-1143	18-1157	18-1159 ⑤	18-1155
Alpha One Gen II (CR)	1991-95	D469859 - F679999	18-1158	18-1117	18-1143	—	—	—
Alpha One Gen II	1996-97	F680000 - K999999	18-1158	18-1117	18-1143	18-1157	18-1156	18-1155
Alpha One Gen II (CR)	1996-97	F680000 - K999999	18-1158	18-1117	18-1143	—	—	—
Alpha One Gen II	1998-newer	L100040 - UP	18-1158	18-1117	18-1143	18-1157	18-1156 ③	18-1155
Alpha One Gen II (CR)	1998-newer	L100040 - UP	18-1158	18-1117	18-1143	—	—	—
II	1962-67	1474909 - 2275488	—	—	—	N/A	18-1156 ③	N/A
II	1968-69	2398798 - 2671321	—	—	—	—	18-1162	18-1156 ③
II-TR	1973-76	3377316 - 4794899	—	—	18-1161 ①	—	—	N/A
TR	1973-93	4794900 - UP	—	—	18-1161 ①	—	—	N/A
TRS	1973-93	4794900 - UP	18-1158	—	—	—	18-1159	N/A

① 18-1161 Top Bearing /
18-1163 Bottom Bearing

② Torrington#B1616
③ Prop Shaft Drive Gear

④ #15520 Stamped on Cup
⑤ Use 18-1173 for 2.40:1 ratio only (new style lower gears) our 18-2206-1



18-2349
SHIFT SHAFT SLEEVE
Replaces: 23-67370



18-2244
18-22441-9①
(PKG. OF 50 WITHOUT GASKET)
DRAIN PLUG
Replaces: 10-79953A2, 10-79953, 10-79953Q04, 10-28634, 10-28634A1, 10-20259, 816610A1, 816610A2, F40109, 10-F50109
For: #1/R/MR/Alpha/Alpha I Gen II Both Upper And Lower Units



18-2375
18-23751-9①
(PKG. OF 50 WITHOUT GASKET)
DRAIN PLUG MAGNET
Replaces: 10-14834, 10-14834A1, 22-67892, 22-67892A1, 22-67892A05, 22-67892A06, 22-8M0058389 (Magnet)
For: Alpha MR/Gen II lower units Not to be used on #1/R lower units



18-2460
PLUG KIT
Replaces: 22-88847A1, 11-88462
Fits: Mercuriser Stern Drives



18-72005
NUT AND WASHER KIT
Fits: Mercuriser R/MR/Alpha/Gen II Drives



18-4220
THRUST WASHER
Replaces: 13171, 77987
V-6, Outboards & Mercuriser Sterndrives

① 18-4220D



18-3784
THRUST WASHER
Replaces: 805100
Fits: Bravo III (Front)



18-3701
PROP NUT KIT
 Replaces: 11-52707A1, 11-52707A2, 11-52707Q1

② **18-3701D** 

CONTAINS			
Part #	O.E. #	Description	Qty
18-3200	14-31210, 14-816629, 14-816629Q, 14-F697140	Tab Washer	2
18-3700	11-52707	Prop Nut	1



18-3755
PROP NUT KIT
 Fits: Bravo III (Front)



18-3756
PROP NUT KIT
 Fits: Bravo III (Rear)

PKG. OF 10



18-3200
18-3200-9①
TAB WASHER
 Replaces: 14-31210, 14-816629, 14-816629Q, 14-F697140



18-3787
TAB WASHER
 Replaces: 805101T
 Fits: Bravo III (Rear)

PKG. OF 10



18-3788-9①
TAB WASHER
 Replaces: 14-34817
 Fits: Bravo II



18-72510
STUD KIT
 Fits: Mercruiser Coupler to Flywheel



18-3783
PROP NUT
 Replaces: 11-859131, 11-805092, 11-805092T
 Fits: Bravo III (Front)



18-3785
PROP NUT
 Replaces: 11-82671127, 11-54034, 11-39907, 11-39823
 Fits: Bravo II



18-3786
PROP NUT
 Replaces: 11-862907, 11-805093
 Fits: Bravo III (Rear)



18-3700
PROP NUT
 Replaces: 11-52707, 11-827614, F7040
 3/4" - 20 thread • 1 1/16" wrench



18-3714
BRASS CASTLE WASHER
 Replaces: 12-31211A2, 12-31211, 12-31211A3, 12-31211Q03
 Fits: Alpha/Bravo I (without Flo-Torq II Hub)
 NOTE: Fits above product with rubber hub propellers (non-Flo-Torq II)



18-4444
PROP WRENCH
 Replaces: 91-95830A1, 91-95830, 91-38277A1



18-4446
PROP WRENCH KIT
 —CONTAINS—

Part #	O.E. #	Description
18-3200	14-31210, 14-816629	Tab Washer
18-3700	11-52707	Prop Nut
18-4444	91-95830A1	Prop Wrench



18-4459
PROP WRENCH
 Replaces: 91-821887A1, 91-859046Q4, 91-859046T4

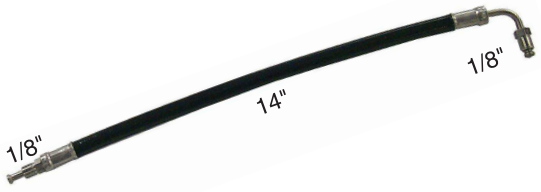

18-2103
POWER TRIM HOSE
 Replaces: 32-47373, 32-66073, 32-68676, 32-73004, 32-79431, 32-86036, 32-86036A1, 32-86036Q

1/8" 14" 1/8"



① Priced per Package

② Items ending in "D" are Display Packaged - Regular number is Non-Display



18-2105
POWER TRIM HOSE
Replaces: 32-45973



18-2106
POWER TRIM HOSE
Replaces: 32-45974

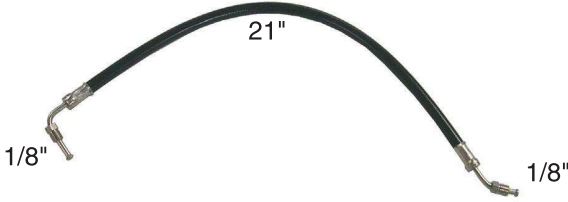

18-2107
POWER TRIM HOSE
Replaces: 32-55816



18-2108
POWER TRIM HOSE
Replaces: 32-59841, 32-59841A1, 32-73123



18-2109
POWER TRIM HOSE
Replaces: 32-59842, 32-73005



POWER TRIM HOSE
Starboard
Connector to bottom of trim cylinder MCM 120-260 & BRAVO

Part #	O.E. #	Description
18-2114	32-99902-1, 32-864960	Trim Cyl. Casting #14034-1
18-2136*	32-99902, 32-864589	Trim Cyl. Casting #98704, 98704-1

* Approximately 11 1/4" long



POWER TRIM HOSE
Port • Connector to bottom of trim cylinder MCM 120-260 & BRAVO

Part #	O.E. #	Description
18-2115	32-99903-1, 32-864959	Trim Cyl. Casting #14035-1
18-2137*	32-99903, 32-864588	Trim Cyl. Casting #98703, 98703-1

* Approximately 11 1/4" long

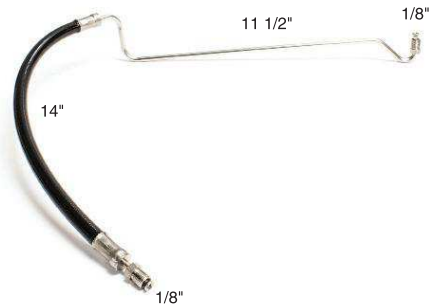

18-2112
POWER TRIM HOSE
Replaces: 32-87234

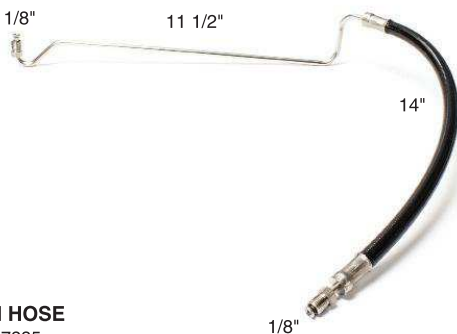

18-2113
POWER TRIM HOSE
Replaces: 32-87235



18-2435
POWER TRIM HOSE
Replaces: 32-861127, 32-95858
Fits: R/MR/Alpha/Alpha Gen II/Bravo I, II, III/Bravo X, XR, XZ
Serial number 0W099999 and below without quick connect fittings.
OEM hose color is black.

 <p>15" 1/8"</p> <p>18-2116 POWER TRIM HOSE Replaces: 32-99904, 32-99904Q</p>	 <p>51"</p> <p>18-2436 POWER TRIM HOSE Replaces: 32-861128, 32-95859 Fits: R/MR/Alpha/Alpha Gen II/Bravo I, II, III/Bravo X, XR, XZ Serial number 0W099999 and below without quick connect fittings. OEM hose color is gray.</p>	 <p>18-2126 POWER TRIM HOSE Trim Pump to reverse lock 10 ft (3.04 m) length Replaces: 32-52951A1, 32-48418 Fits: MC-1 Drive (w/ in-line engines) and II drives</p>
--	--	---

POWER TRIM HOSE APPLICATION

Stern Drive Model	Years	Serial #	Trim Cylinder to Connector (Port Down)	Trim Cylinder to Connector (Port Up)	Trim Cylinder to Connector (Stbd Down)	Trim Cylinder to Connector (Stbd Up)	Pump to Hydraulic Connector	Pump to Hydraulic Connector	Connector to Reverse Lock Valve	Hydraulic Pump & Reverse Lock Valve
120, 140	1967-69	2062141 - 2791956	—	18-2106	—	18-2105	—	N/A	—	18-2126
120, 140	1970-73	2791957 - 3780849	18-2103	18-2103	18-2103	18-2103	18-2107	N/A	—	18-2126
120, 140	1974-82	4893635 - 6225576	18-2103	18-2103	18-2103	18-2103	18-2107	N/A	18-2109	18-2126
470/485	1976-82	4208730 - 6225576	18-2103	18-2103	18-2103	18-2103	18-2107	N/A	18-2109	18-2126
160	1967-69	2065190 - 2763441	—	18-2106	—	18-2105	—	N/A	—	18-2126
165	1970-73	2763442 - 3780849	18-2103	18-2103	18-2103	18-2103	18-2107	N/A	—	18-2126
165	1974-81	3780850 & UP	18-2103	18-2103	18-2103	18-2103	18-2107	N/A	18-2109	18-2126
888	1974 & UP	3106717 & UP	18-2103	18-2103	18-2103	18-2103	18-2108	N/A	18-2109	—
225/233	1974-77	3856268 & UP	18-2103	18-2103	18-2103	18-2103	18-2108	N/A	18-2109	—
228/898/250/260	1977-82	4782330 - 6225576	18-2103	18-2103	18-2103	18-2103	18-2108	N/A	18-2109	—
R/MR/Alpha/SS	1983-90	6225577 & UP	18-2137 ③	18-2116	18-2136 ③	18-2116	18-2436	18-2435	N/A	N/A
R/MR/Alpha/SS	1983-90	6225577 & UP	18-2115 ④	18-2116	18-2114 ④	18-2116	18-2436	18-2435	N/A	N/A
Alpha One GEN II	1991-97	D469859 & UP	18-2115	18-2116	18-2114	18-2116	18-2436	18-2435	N/A	N/A
Alpha One GEN II ⑥	1998 & UP	0L100040 & UP	18-2115	18-2116	18-2114	18-2435	18-2436	18-2435	N/A	N/A
Bravo I, II & III ⑥	1988 & UP	B664190 & UP	18-2137	18-2116	18-2136	18-2116	18-2436	18-2435	N/A	N/A
Blackhawk	1994-95	F186717 & UP	18-2137	18-2116	18-2136	18-2116	18-2436	18-2435	N/A	N/A
II (1.78)	1968-69	2398798 - 2671321	18-2103	18-2103	18-2103	18-2103	—	N/A	—	18-2126
III	1968-72	2373127 - 3002613	18-2103	18-2103	18-2103	18-2103	—	N/A	—	—
215E/H	1970-72	2909035 - 2915034	18-2103	18-2103	18-2103	18-2103	—	N/A	—	—
TR/TRS	1973-93	3377316 & Up	18-2103 ②	18-2103	18-2103 ②	18-2103	—	N/A	—	—
TR/TRS	1973-93	3377316 & Up	18-2103 ②	18-2103	18-2103 ②	18-2103	—	N/A	—	—
TR/TRS	1973-93	3377316 & Up	— ①	18-2103	— ①	18-2103	—	N/A	—	—

① 90° hose end
② External trim lines

③ Internal cylinder lines
④ Oildyne pump

⑤ 18-2436 OEM hose color is gray, 18-2435 OEM hose color is black
⑥ Serial number 0W099999 and below without quick connect fittings.

- ★ High quality EPDM rubber cups
- ★ Metal hose connector complete with rubber washer
- ★ Use with a standard garden hose
- ★ Corrosion resistant dicromate finish
- ★ Installs in seconds
- ★ No tools required



18-9010
MOTOR FLUSHER
Heavy Duty

Flushes cooling system of salts and sediments and allows engine to idle for tuning and engine adjustment in your own driveway. Simply slip attachment over the engine's side water intakes. Coated spring steel arms clamp suction cup securely over the engine's side water intakes.

STAINLESS STEEL LOCKNUTS



Part #	O.E. #	Thread Size	Std. Pkg.
*18-3720 ③	11-34932	3/8" - 24	1
*18-3721 ③	11-34933, 11-95702, 11-82671015, 11-46355, 11-33962, 11-29241, 11-24648, 11-22178, 11-21298	7/16" - 20	6
*18-3722 ③	11-35888, 11-20361, 11-8267089	1/4" - 28	5
*18-3723 ③	11-45592	5/16" - 24	1

*To order locknuts in a package of 5, add -9 to end of part number



18-9099

TRAWLING CLIPS

Replaces: 817019A1, 817019Q2, 817019A2, 879078, 86459A2, 86459A1, 86459, 41155A2, 41155A1, 32657A4, 32657A3
I.D. 3/4" x 11 1/8" length
For: all ALPHA I, ALPHA Generation II, Bravo I, II, III, and Blackhawk



18-2372

TRIM CYLINDER END CAP

Replaces: 88035
1.850 Cap Diameter
For: R/MR/Alpha



18-2373

TRIM CYLINDER END CAP

Replaces: 14698, 14698T, 14698T10 806191T, 8M0110717
1.890 Cap Diameter
For: R/MR/Alpha/ Gen II/Bravo
 (Seals included)

PKG. OF 2



18-2465-9^④

PIVOT PIN END CAP

Replaces: 19-14842, 19-148421
For: R/MR/Alpha One (1983-90)
 Serial No. 6225577 and up
 I/II/III (1988-02) Serial No. 6225577

PKG. OF 2



18-2466-9^④

PIVOT PIN END CAP

Replaces: 19-815951
For: Alpha One Gen II (1991-02)
 Serial No. OD469859 and up



18-2461

TRIM CYLINDER ANCHOR PIN KIT

Replaces: 17-44166T1
For: Bravo I/II/III (1988-02)
 Serial No. 6225577 and up



18-2462

TRIM CYLINDER ANCHOR PIN KIT

Replaces: 17-14873A1, 17-85056
For: R/MR/Alpha One (1983-90)
 Serial No. 6225577 and up (Front)



18-2463

TRIM CYLINDER ANCHOR PIN KIT

Replaces: 17-14872A1, 17-99207
For: R/MR/Alpha One (1983-90)
 Serial No. 6225577 and up (Rear)



18-2464

FRONT AND REAR ANCHOR PIN KIT

Replaces: 17-815953T1, 56-864641A24, 56-18541A75
For: All Alpha One Gen II



18-7633

TRIM SENDER/LIMIT KIT

Replaces: 805320A03, 805320A1, 96863A15, 88678A5, 88678A4, 63115A12, 17693A2
Fits: MC-I, R, MR, Alpha, Alpha Gen II, Bravo drives



18-2142

POWER TRIM CYLINDER

Replaces: 45706A1, 45706A3, 45706A6, 45706A8, 45706A12, 45706A14
Fits: All Stern Drive Models with internal lines: 120, 140, 160, 165, 888, 898, 228, 225-S, 233, 250, 260, 470 & 485



18-2148

POWER TRIM CYLINDER HOUSING

Replaces: 45523, 45706A4, 77442A1, 77443
Fits: All Stern Drive Models: 120, 140, 160, 165, 888, 898, 228, 225-S, 233, 250, 260, 470 & 485

③ This product is priced per piece. To order priced per package, please add -9 to the part number.

④ Priced per package



18-2420
POWER TRIM CYLINDER
Replaces: 14034A3, 14034A5, 14034F1, 14034T, 14034T10
For: R/MR/ALPHA (Starboard)



18-2421
POWER TRIM CYLINDER
Replaces: 14035A3, 14035A5, 14035F1, 14035T, 14035T10
For: R/MR/ALPHA (Port)



18-2422
POWER TRIM CYLINDER
Replaces: 815935A7, 815935A3
For: GEN II (Port) (S/N F680000 - UP)



18-2423
POWER TRIM CYLINDER
Replaces: 815954A7, 815954A3
For: GEN II (Starboard) (S/N F680000 - UP)



18-2424
POWER TRIM CYLINDER
Replaces: 98703A11, 98703A12, 98703A17, 98703A26
For: BRAVO (Port)



18-2425
POWER TRIM CYLINDER
Replaces: 98704A11, 98704A12, 98704A17, 98704A26, 8M0708280
For: BRAVO (Starboard)



18-2426
POWER TRIM CYLINDER
Replaces: 98703A3
For: R/MR/ALPHA (Port)



18-2427
POWER TRIM CYLINDER
Replaces: 98704A3
For: R/MR/ALPHA (Starboard)



18-2649
POWER TRIM SEAL KIT
Replaces: 25-87400A2



18-2291
TRIM CYLINDER REPAIR KIT
Replaces: 25-60342A2, 25-60342A1
Fits: All Stern Drive Models: 120, 140, 160, 165, 888, 898, 228, 225-S, 233, 250, 260, 470 & 485



18-2428
TRIM CYLINDER REPAIR KIT
Replaces: 87399A2, 87399A1
For: R/MR/ALPHA I, BRAVO



18-2429
TRIM CYLINDER REPAIR KIT
Replaces: 87399A3
For: ALPHA I GEN II

POWER TRIM CYLINDER APPLICATION

Model	Year	Serial No.	Trim Cylinder Port	Trim Cylinder Starboard	Housing Port	Housing Starboard	Trim Cylinder Seal Kit
120 / 140 4 cyl	1967-1969	2062141-2791956	18-2142	18-2142	N/A	N/A	N/A
120 / 140	1970-1977	2791957-4893634	18-2142	18-2142	N/A	N/A	18-2291
120 / 140	1978-1982	4893635-6225576	18-2142 ③	18-2142 ③	N/A	N/A	18-2291
120 / 140	1978-1982	4893635-6225576	N/A ④	N/A ④	N.L.A	N.L.A	18-2291
160 6 cyl	1967-1969	2062141-2791956	18-2142	18-2142	N/A	N/A	N/A
160	1967-1969	2065190-2763441	18-2142	18-2142	N/A	N/A	N/A
165	1970-1977	2763442-4890459	18-2142	18-2142	N/A	N/A	18-2291
165	1978-1981	4890460-4890459	18-2142 ③	18-2142 ③	N/A	N/A	18-2291
225 / 233	1974-1977	3856268 & UP	18-2142	18-2142	N/A	N/A	18-2291
250	1977	4791300-4898729	18-2142	18-2142	N/A	N/A	18-2291
260	1978-1982	4898730-6225576	18-2142 ③	18-2142 ③	N/A	N/A	18-2291
470 / 485	1976-1977	4208730-4893934	18-2142	18-2142	N/A	N/A	18-2291
470 / 485	1978-1982	4893835-6225575	18-2142 ③	18-2142 ③	N/A	N/A	18-2291
898 / 228	1977	4782330-4898729	18-2142	18-2142	N/A	N/A	18-2291
898 / 228	1978-1982	4898730-6225576	18-2142 ④	18-2142 ④	N/A	N/A	18-2291
ALL # 1 DRIVES ⑤	1970-1982	2791957-6225576	18-2142	18-2142	18-2148	18-2148	18-2291
R / MR / ALPHA I	1983-1990	6225577-D469858	18-2426 ①	18-2427 ①	N/A ⑤	N/A ⑦	18-2649
R / MR / ALPHA I	1983-1990	6225577-D469858	18-2426 ①	18-2427 ①	N/A ⑥	N/A ⑧	18-2649
R	1983-1990	6225577 & UP	18-2426 ①	18-2427 ①	N/A	N/A	18-2649
MR	1983-1990	6225577 & UP	18-2426 ①	18-2427 ①	N/A	N/A	18-2649
ALPHA I	1983-1990	6225577 & UP	18-2426 ①	18-2427 ①	N/A	N/A	18-2649
ALPHA I SS	1986-1989	A545004 & UP	18-2426 ①	18-2427 ①	N/A ⑤	N/A ⑦	18-2649
ALPHA I SS	1986-1989	A545004 & UP	18-2421 ②	18-2420 ②	N/A	N/A	18-2649
ALPHA I SS	1986-1989	A545004 & UP	18-2422	18-2423	N/A	N/A	18-2649
R	1983-1990	6225577 & UP	18-2421 ②	18-2420 ②	N/A	N/A	18-2649
MR	1983-1990	6225577 & UP	18-2421 ②	18-2420 ②	N/A	N/A	18-2649
ALPHA I	1983-1990	6225577 & UP	18-2421 ②	18-2420 ②	N/A	N/A	18-2649
ALPHA I GEN II	1991-2001	D469859 & UP	18-2422	18-2433	N/A	N/A	18-2649
BRAVO I	1988-2010	B664190 & UP	18-2424	18-2425	N/A	N/A	18-2649
BRAVO II	1988 & UP	B664190 & UP	18-2424	18-2425	N/A	N/A	18-2649
BRAVO III	1988 & UP	B664190 & UP	18-2424	18-2425	N/A	N/A	18-2649
BRAVO SEACORE	2007-2010	W900000 & UP	N/A	N/A	N/A	N/A	18-2649
BLACKHAWK	1994-1995	F186717 & UP	18-2424	18-2425	N/A	N/A	18-2649

- ① 11 3/8" LONG TUBES - INTERNAL CYLINDER LINES
- ② 13 3/4" LONG TUBES - INTERNAL CYLINDER LINES
- ③ CASTING #14034 1
- ④ CASTING 14035 1
- ⑤ CASTING #98703
- ⑥ CASTING #98703 1
- ⑦ CASTING #98704
- ⑧ EXTERNAL TRIM LINES
- ⑨ INTERNAL TRIM LINES
- ⑩ USE WITH 15 9/16" LONG TRIM CYLINDER TUBE
- ⑪ USE WITH 16 3/16" LONG TRIM CYLINDER TUBE
- ⑫ TRIM CYLINDER WITH INTERNAL TRIM LINES
- ⑬ TRIM CYLINDERS USING EXTERNAL TRIM LINES
- ⑭ EXCLUDES TR, TRS, 215E, H, & EARLY II & III DRIVES

PKG. OF 5



18-4252
18-4252-9 ⑦
CONTINUITY SPRING
Replaces: 24-46312
Grounds the trim cylinder to the pivot pin shaft.



18-2151
7 1/2" (Front)
Replaces: 17-45738

18-2152
10 1/2" (Rear)
Replaces: 17-45735

PIVOT PINS
Used on 120, 120-260, 140, 165, 225S, 233, 250, 470, 888, 898/228
Use **18-2701** Bushing



18-2393
TRIM CYLINDER PIVOT PIN
Replaces: 17-14872
For: Trim cylinder rear R/MR/Alpha
Use: **18-2702-1** Bushing



18-2394
TRIM CYLINDER PIVOT PIN
Replaces: 17-14873
3/8" - 24 thread
For: Trim cylinder front R/MR/Alpha
Use: **18-2702-1** Bushing



18-2395
TRIM CYLINDER PIVOT PIN
Replaces: 17-815953, 17-815953A1
For: Trim cylinder front & rear Gen II



18-2396
TRIM CYLINDER PIVOT PIN
9 1/4" overall length • 7 1/2" shaft length
Replaces: 17-44166
For: Rear Bravo



18-2397
TRIM CYLINDER PIVOT PIN
Replaces: 17-44167A1, 17-44167
For: Front Bravo

- ④ Standard package of 8 priced per piece
- ⑤ Standard package of 8 priced per package
- ⑥ Priced per Package of 4
- ⑦ Priced per Package

<p>PKG. OF 8</p>  <p>POWER TRIM BUSHING 18-2701 18-2701-04® 18-2701-9④ Replaces: 23-89574, 23-61290, 23-45736 Fits: 120/260 Drive Units (S/N 6225276 & Down)</p>	<p>POWER TRIM BUSHING 18-2702-1⑤ 18-2702-04® 18-2702-1-9④ Replaces: 23-99291, 23-99291T Fits: 120/260 Drive Units (S/N 6225277 & UP)</p>	<p>PKG. OF 8</p>  <p>18-4288 18-4288-9⑦ POWER TRIM BUSHING Replaces: 23-807073, 23-44165 For: Bravo</p>	 <p>18-2345 18-2345-9⑦ TRIM CYLINDER ANCHOR PIN E-RING Replaces: 53-815949 For: Gen II</p>
<p>PKG. OF 2</p>  <p>18-4289 18-4289-9⑦ RETAINING RING Replaces: 53-805272 For: Bravo</p>	<p>PKG. OF 4</p>  <p>18-2336 18-2336-9⑦ TRIM BUSHING Replaces: 23-47392, 23-61291, 23-90203 For: TR & TRS(1977-93), Alpha One SS (1986-1989) , SSM(1982-1995)</p>	<p>PKG. OF 8</p>  <p>18-2341-1 18-2341-1-9⑦ POWER TRIM BUSHING Replaces: 23-815950, 23-8159501, 23-815950Q01 For: Gen II</p>	<p>PKG. OF 5</p>  <p>18-3232 18-3232-9⑦ PLUG Replaces: 19-47579, 19-475791 For: MR Alpha</p>

Zinc is for saltwater only applications.
 Magnesium is for fresh water only applications.
 Aluminum is for brackish water or salt water environments.

 <p>18-6154A 18-6154M 18-6154Z ANODE KIT Bravo III (2004 and Newer)</p>	 <p>18-6158M 18-6158Z 18-6158A ANODE KIT Replaces: 888755Q01 (18-6158M), 888756Q01 (18-6158A), 97-888756Q03 (18-6158A, M), 888756A1 (18-6158A, M) Mercuriser Alpha I Gen II (1991 & UP)</p>	 <p>18-6159A 18-6159M 18-6159Z ANODE KIT Replaces: 888758Q01 (18-6159A), 888757Q01 (18-6159M), 97-888758Q03 (18-6160A), 888758A1 (18-6160A), 97-888759Q03 (18-6160M), 888759A1 (18-6160AM) Mercuriser Bravo I - All Years</p>	 <p>18-6160A 18-6160M 18-6160Z ANODE KIT Replaces: 888761Q01 (18-6160A), 97-888761Q03 (18-6160A), 888761A1 (18-6160A), 888760Q01 (18-6160M), 97-888760Q03 (18-6160M), 888760A1 (18-6160M) Bravo II (1989 & Up), Bravo III (1989-03)</p>
 <p>① 18-6117A ② 18-6117M ③ 18-6117Z ANODE Replaces: 97-806188A1, 97-806188Q01 For: Bravo One bearing carrier</p>	 <p>② 18-6241 ③ 18-6011 ① 18-6011A ANODE Replaces: 31640, 31640A1, 97-31640Q4, 31640T6, 97-31640B4, 31640A4, 31640A2, 316404, 316403, 72436A1 For use on R/MR/Alpha One, Sterndrive & Transom Assembly (1983-90) & prior drives, Alpha One, Gen II (1991 & up)</p>	 <p>③ 18-6012 ANODE Replaces: 34127A1, 34127T2, 34127A2, 34127T1, 34127 For use on R/MR/Alpha One (Sterndrive & Transom Assembly 1983-90) & prior drives</p>	 <p>③ 18-6013 ANODE Replaces: 34762A1, 97-34672C, 32170, 32170A1 For use on Alpha One SS (Sterndrive & Transom Assembly 1983-89) & prior drives</p>
 <p>③ 18-6014 ① 18-6014A ANODE Replaces: 46399A1, 822777A1, 822777Q1, 822777A4, 822777A3, 8227772, 822777, 46399A2 For use on Alpha One SS (1982-89)</p>	<p>PKG. OF 2</p>  <p>⑥③ 18-6015-9 ③⑤ 18-60151-9 ⑥① 18-6015A-9 ⑥② 18-6242-9 ANODE Replaces: 55989A3, 55989Q9, 55989T9, 55989A9, 55989A4, 55989 Bravo I, II, III (1988-95)</p>	 <p>③ 18-6016 ③④ 18-60161 ③⑤ 18-60161-9 ① 18-6016A ② 18-6244 ANODE Replaces: 76214, 762142, 762142A1, 76214A5, 97-76214Q5, 786214A2, 97-762145 200, 225, 250HP V-155-V-200, & All Bravos, Alpha One, Gen II (1991 & up) (Threaded through)</p>	 <p>③ 18-6066 ① 18-6066A ② 18-6243 ANODE Replaces: 43994A2, 821631Q1, 821631C, 821631B1, 821631A1 For use on R/MR/Alpha One (Sterndrive & Transom Assembly 1983-90)</p>

① Aluminum ② Magnesium ③ Zinc
 ④ Standard package of 10 priced per piece ⑤ Standard package of 10 priced per package
 ⑥ Standard package of 2 priced per package

Zinc is for saltwater only applications.
 Magnesium is for fresh water only applications.
 Aluminum is for brackish water or salt water environments.



- ② 18-6114
- ③ 18-6067
- ① 18-6067A

ANODE

Replaces: 97-806189, 806189A1, 97-806189Q1
For: Alpha One, Gen II (1991 & up)



- ③ 18-6068

ANODE

Replaces: 826134, 826134A1, 97-826134Q
For: Alpha One (Gen II)



- ② 18-6099
- ③ 18-6080
- ① 18-6080A

ANODE

Replaces: 815933A1, 821629A1, 97-821629Q1
For: Alpha One (Gen II) (1991 & UP)



- ② 18-6089
- ③ 18-6092
- ① 18-6092A

ANODE

Replaces: 97-806190, 806190A1, 97-806190Q1, 806190T1, 97-806190B4
All Bravos



- ② 18-6079
- ③ 18-6093
- ① 18-6093A

ANODE

Replaces: 806105, 806105A1, 806105Q1, 806105T1
For: Alpha One (Gen II) (1991& UP)



- ① 18-6150A
- ② 18-6150M
- ③ 18-6150Z

ANODE KIT

Replaces: 888756Q02, 888756Q4, 888756A2
For: MR & Alpha One Drives



- ② 18-6240
- ③ 18-6094
- ① 18-6094A

ANODE

Replaces: 821630C2, 821630A1, 97-821630Q1, 817373A1
All Bravos

— CONTAINS —

Part #	Desc.	O.E.#	Qty.
18-2599	Face Seal and Tool	26-818575A2	1
18-2564	Water Pump Base To Face Plate Gasket	27-43033-1	1
18-2566	Face Plate to Water Pump Cover Gasket	27-817277	1
18-2945	Sealing Washer	12-19183	1
18-2944	Seal	26-45577	1
18-2002	Oil Seal	26-30550, 26-76868	1
18-2009	Oil Seal	26-892361	1
18-2013	Oil Seal	26-16977	1
18-2014	Oil Seal	26-89238	1
18-2054	Oil Seal	26-81646-1	1
18-2056	Oil Seal	26-965031	2
18-2076	Oil Seal	26-12224	1
18-2077	Oil Seal	26-14077	1
18-7159	O-Ring	25-31534	1
18-7168	O-Ring	25-48171	2
18-7176	O-Ring	25-90011	1
18-7420	O-Ring	25-21836	2
18-7440-1	O-Ring	25-36318	2
18-2056	Oil Seal	26-66302	2
18-7413	O-Ring	25-62702	1



18-2646-1 LOWER UNIT SEAL KIT

Replaces: 26-816575A3, 26-816575A1
For: Alpha Gen II

— CONTAINS —

Part #	Description	O.E. #	Qty.
18-2516	Bravo Outdrive Seal	16755	1
18-1240	Outdrive Seal	12708	1
18-2945	Gear Housing Drain Screw Gasket	12-19183	1
18-7198	O-Ring	25-45710	1
18-7102	O-Ring	25-62706	1
18-7105	O-Ring	25-62705	1
18-7449	O-Ring	25-97387	1
18-7153	O-Ring	25-25439	2
18-7167	O-Ring	25-97386	1
18-2010	NSS	26-12709	1
18-2715	Spring Kit	24-17997A1	1
18-7117	O-Ring	25-35027	1
18-7169	O-Ring	25-70937	1



18-2643 UPPER UNIT SEAL KIT

Replaces: 26-16709A2, 26-16709A1
BRAVO - BLACKHAWK

— CONTAINS —

Part #	Desc.	O.E. #	Qty.
18-2944	Seal Gasket	26-45577	1
18-2945	Drain Screw Gasket	12-19183	3
18-7188	Drain Screw O-Ring	26-805726	1
18-7169	O-Ring	25-70937	1
18-7161	O-Ring	25-32546	1
18-7420	O-Ring	25-25439	2
18-7103	O-Ring	25-29845	2
18-7117	O-Ring	25-35027	1
18-2056	Oil Seal	26-965031	2
18-2003	Oil Seal	26-68493, 26-32080, 26-36054, 26-823894	1
NSS	Water Tube Seal	26-88397	1
18-3289	Double Lip Seal	26-864319	1
18-2715	Spring Kit	24-17997A1	1



18-2644 UPPER UNIT SEAL KIT

Replaces: 26-88397A1
ALPHA I GENERATION II

SEAL KIT APPLICATION BEGINS ON PAGE 856

- ① Aluminum
- ② Magnesium
- ③ Zinc
- ④ Standard package of 10 priced per piece

— CONTAINS —

Part #	Description	O.E. #	Qty.
18-2944	Seal Gasket	26-45577	1
18-2945	Gear Housing Drain Screw Gasket	12-19183	1
18-7163	O-Ring	25-33465	1
18-7159	O-Ring	25-31534	1
18-2002	Oil Seal	26-70019, 26-73838	2
18-0563	Seal	26-36556	1

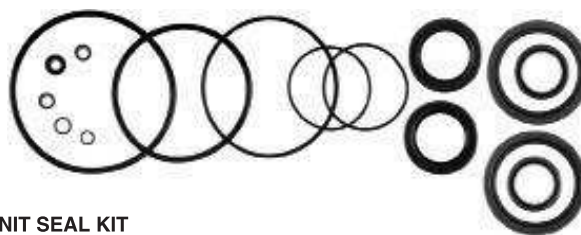

18-2645
LOWER UNIT SEAL KIT
Replaces: 26-76868A1, 26-76868A2, 26-76868A04
 Bravo I, II & III MODELS

— CONTAINS —

Part #	Description	O.E. #	Qty.
18-2945	Gear Hsg. Drain Screw Gasket	12-19183	2
18-0894	Water Pocket Cover Gasket	27-55810	1
18-2003	Oil Seal	26-823894	1
18-2049	Oil Seal	26-32511	1
18-2056	Oil Seal	26-965031	1
18-2944	Seal Ring Gasket	26-45577	1
18-3110	Bushing	26-38970	1
18-7153	O-Ring	25-25439	2
18-7161	O-Ring	25-32546	1
18-7169	O-Ring	25-70937	1
18-7445	O-Ring	25-55801	1



18-2648
UPPER UNIT SEAL KIT
Replaces: 26-32511A1
 S/N 1684188 & UP
For: #1 Units (Including ALPHA) (Also fits 888 Stern drive)
 S/N 3106717 & UP

— CONTAINS —

Part #	Description	O.E. #	Qty.
18-2919	Water Pump to Gear Hsg. Gasket	27-42631-1	1
18-3110	Grommet	26-38970	1
18-2002	Oil Seal	26-70019, 26-73838	1
18-2013	Oil Seal	26-16977	2
18-2014	Oil Seal	26-89238	1
18-2826	Water Pump Base to Gear Hsg. Gasket	27-85610-1	1
18-2914	Lower Water Pump to Wear Plate Gasket	27-85608-1	1
18-2915	Upper Water Pump to Wear Plate Gasket	27-85609-1	1
18-2944	Seal Ring Gasket	26-45577	1
18-2948	Gear Housing Plastic Flush Screw Gasket	12-49221-1	1
18-7158	O-Ring	25-30613	1
18-7159	O-Ring	25-31534	1
18-7162	O-Ring	25-33145	1
18-7176	O-Ring	25-90011	1
—	O-Ring	25-38099	1
18-2154	Bushing, Shift Shaft	23-30617A2	1
18-2076	Line Cutter Oil Seal	26-12224	1
18-7426	O-Ring	25-30271	1
18-2945	Gear Housing Drain Screw Gasket	12-20260, 12-19183	2

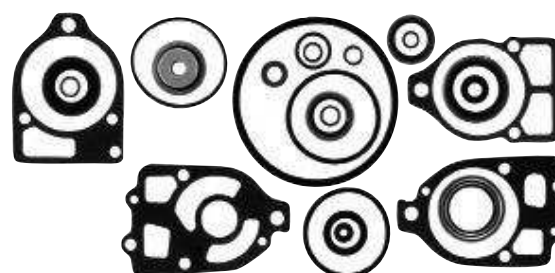

18-2652
LOWER UNIT SEAL KIT
Replaces: 26-33144A2, 26-33144A1, 26-89238A1
 S/N 1684188 & UP
For: #1 Units (Including ALPHA)

— CONTAINS —

Part #	Description	O.E. #	Qty.
18-2652	Lower Gear Housing Seal Kit	26-33144A2	1
18-1155	Ball Bearing	30-88957A1	1
18-1117	Pinion Bearing	31-42647A1	1
18-1143	Tapered Roller Bearing	31-36387A1	1
18-3719	Pinion Nut	11-35921	1
18-2299	Tab Washer	14-79447	1
18-2298	Tab Washer	14-18323	1
18-1158	Needle Roller Bearing	31-30956	1
18-1159	Tapered Roller Bearing	31-35928A1	1
18-2285	Shim Kit	15-47397A1	1
18-1157	Needle Roller Bearing	31-30895	1
18-2343	Washer	12-982721	1
18-2294	Shim Kit	2470	1



18-8208
SEAL & BEARING KIT
Replaces: 31-803090T1
For: MR/Alpha Drive

— CONTAINS —

Part #	Description	O.E. #	Qty.
18-2340	Shift Shift Rubber Washer	12-31266	1
18-2076	Oil Seal	26-12224	1
18-7159	O-Ring	25-31534	1
18-2002	Oil Seal	26-76868	1
18-3109	Water Tube	23-29804	1
18-2154	Shift Bushing	23-30617A2	1
18-3116	Housing	46-96148A1	1
18-3017	Impeller	47-89984	1
18-2914	Water Pump Gasket	27-85608-1	1
18-7158	O-Ring	25-30613	1
18-7176	O-Ring	25-90011	1
18-2944	Seal Ring Gasket	26-45577	1
18-7173	O-Ring	25-30224	1
18-2826	Water Pump Base to Gear Housing Gasket	27-85610-1	1
18-2915	Water Pump Gasket	27-85609-1	1
18-3117	Plate	32435	1
18-7162	O-Ring	25-33145	1
18-2919	Water Pump Gasket	27-42631-1	1
18-2801	Water Pump Gasket	27-32438	1
18-7426	O-Ring	35-30271	1
18-2945	Drain Gasket	26-20260, 12-19183	2
18-3110	Grommet	26-38970	1
18-2013	Seal	26-16977	1
18-2014	Seal	26-89238	1



18-8370
COMPLETE LOWER GEAR CASE REBUILD KIT
 Includes Water Pump and Complete Seal Kit
For: Mercuriser R/MR/ALPHA 1

SEAL KIT APPLICATION BEGINS ON NEXT PAGE

Model	Year	Beginning Serial #	Ending Serial #	Driveshaft Hsg Seal Kit	J-Joint Seal	U-Joint Carrier Seal	Gear Hsg Seal & Brg Kit	Gear Hsg Seal Kit	Brg Carrier O-Ring	Brg Carrier Seal
60 / 80 / 90	1965-1972	1830753	3225967	N/A	N.L.A.	N/A	N/A	N/A	18-7160	18-2011
IA / IB / IC / EZ SHIFT	1964-1966	1684188	2065186	18-2648	18-2003	18-0577	N/A	18-2652	18-7159	18-2002
120 / 140	1967-1982	2062141	6225576	18-2648	18-2003	18-0577	N/A	18-2652	18-7159	18-2002
470 / 485	1976-1982	4208730	6225575	18-2648	18-2003	18-0577	N/A	18-2652	18-7159	18-2002
160 / 165	1967-1981	2065190	& UP	18-2648	18-2003	18-0577	N/A	18-2652	18-7159	18-2002
888	1971-1977	3106717	& UP	18-2648	18-2003	18-0577	N/A	18-2652	18-7159	18-2002
225 / 233	1974-1977	3856268	& UP	18-2648	18-2003	18-0577	N/A	18-2652	18-7159	18-2002
888 / 228 / 250 / 260	1977-1982	4782330	6225576	18-2648	18-2003	18-0577	N/A	18-2652	18-7159	18-2002
R	1983	6225577	& UP	18-2648	18-2003	18-0577	N/A	18-2652	18-7159	18-2002
MR ALPHA ONE	1984-1990	6225577	D469858	18-2648	18-2003	18-0577	18-8208	18-2652	18-7159	18-2002 ③
MR ALPHA ONE	1984-1990	6225577	D469858	18-2648	18-2003	18-0577	18-8208	18-2652	18-7159	18-2077 ①
MR ALPHA ONE	1984-1990	6225577	D469858	18-2648	18-2003	18-0577	18-8208	18-2652	18-7159	18-2076 ②
MR ALPHA ONE (CR)	1984-1990	6225577	D469858	18-2648	18-2003	18-0577	N.L.A.	18-2652	18-7159	18-2077 ①
MR ALPHA ONE (CR)	1984-1990	6225577	D469858	18-2648	18-2003	18-0577	N.L.A.	18-2652	18-7159	18-2076 ②
ALPHA ONE SS	1986-1989	A545004	& UP	18-2648	18-2003	18-0577	N/A	18-2652	18-7159	18-2002 ③
ALPHA ONE SS	1986-1989	A545004	& UP	18-2648	18-2003	18-0577	N/A	18-2652	18-7159	18-2077 ①
ALPHA ONE SS	1986-1989	A545004	& UP	18-2648	18-2003	18-0577	N/A	18-2652	18-7159	18-2076 ②
APLHA ONE GEN II	1991-1995	D469859	F679999	18-2644	18-2003	18-0577	N/A	18-2646-1	18-7159	18-2077 ①
APLHA ONE GEN II	1991-1995	D469859	F679999	18-2644	18-2003	18-0577	N/A	18-2646-1	18-7159	18-2076 ②
APLHA ONE GEN II (CR)	1991-1995	D469859	F679999	18-2644	18-2003	18-0577	N.L.A.	18-2646-1	18-7159	18-2077 ①
APLHA ONE GEN II (CR)	1991-1995	D469859	F679999	18-2644	18-2003	18-0577	N.L.A.	18-2646-1	18-7159	18-2076 ②
APLHA ONE GEN II	1996-1997	F680000	K999999	18-2644	18-2003	18-0577	N/A	18-2646-1	18-7159	18-2077 ①
APLHA ONE GEN II	1996-1997	F680000	K999999	18-2644	18-2003	18-0577	N/A	18-2646-1	18-7159	18-2076 ②
APLHA ONE GEN II (CR)	1996-2010	F680000	& UP	18-2644	18-2003	18-0577	N.L.A.	18-2646-1	18-7159	18-2077 ①
APLHA ONE GEN II (CR)	1996-2010	F680000	& UP	18-2644	18-2003	18-0577	N.L.A.	18-2646-1	18-7159	18-2076 ②
APLHA ONE GEN II	1998-2010	L100040	& UP	18-2644	18-2003	18-0577	N/A	18-2646-1	18-7159	18-2077 ①
APLHA ONE GEN II	1998-2010	L100040	& UP	18-2644	18-2003	18-0577	N/A	18-2646-1	18-7159	18-2076 ②
BRAVO I	1988-2010	B664190	& UP	18-2643	N/A	N/A	N/A	18-2645	18-7159	18-2002
BRAVO I X	2000-2010	M100001	& UP	18-2643	N/A	N/A	N/A	18-2645	18-7159	18-2002
BRAVO I XR/XZ	2000-2010	M100001	& UP	18-2643	N/A	N/A	N/A	N/A	18-7159	N/A
BRAVO II	1988-2010	B664190	& UP	18-2643	N/A	N/A	N/A	18-2645	N/A	N/A ②
BRAVO II	1988-2010	B664190	& UP	18-2643	N/A	N/A	N/A	18-2645	N/A	N/A ①
BRAVO II X	2000-2010	M100001	& UP	18-2643	N/A	N/A	N/A	18-2645	N/A	N/A ②
BRAVO II X	2000-2010	M100001	& UP	18-2643	N/A	N/A	N/A	18-2645	N/A	N/A ①
BRAVO III	1988-2010	B664190	& UP	18-2643	N/A	N/A	N/A	18-2645	N/A	N/A
BRAVO III X	2000-2010	M100001	& UP	18-2643	N/A	N/A	N/A	18-2645	N/A	N/A
BLACKHAWK	1994-1995	F186717	& UP	18-2643	N/A	N/A	N/A	N/A	N/A	N/A
I	1963	1534570	1684187	18-2648	N/A	18-0577	18-2652	N/A	18-7157	18-2002
II	1962-1969	1474909	2671321	N/A	N/A	N/A	N/A	N/A	18-7159	N.L.A.
III	1968-1972	2373127	3002613	N/A	N/A	N/A	N/A	N/A	N/A	N/A
215E/H	1970-1972	2909035	2915034	N/A	N/A	N/A	N/A	N/A	N/A	N/A
TR	1973-1993	3377316	& UP	N/A	N/A	N/A	N/A	N/A	N/A	N/A
TRS	1973-1993	3377316	& UP	N/A	N/A	N/A	N/A	N/A	18-7159	N/A

① Inner ② Outer ③ w/o Fishline Cutter Seal

② 18-4456D



18-4456
EXHAUST PROTECTOR VALVE
 Replaces: 34765A1, 34765A2
 INCLUDES STAINLESS STEEL CLAMP
 3"

② 18-4457D



18-4457
EXHAUST PROTECTOR VALVE
 Replaces: 12644A1, 12644Q01
 INCLUDES STAINLESS STEEL CLAMP
 4"

② 18-4458D



18-4458
EXHAUST PROTECTOR VALVE
 (Fits both 5" & 6" Exhaust)
 INCLUDES STAINLESS STEEL CLAMP

② Items ending in "D" are Display Packaged - Regular number is Non-Display

OIL SEALS

Part #	O.E. #	Shaft Size (in.)	Dimensions (in.)		
			O.D.	Width	
18-0172	26-97530	0.845	1.500	0.315	
18-0515	26-30530	0.540	1.004	0.303	
18-0516	26-30913	0.500	0.839	0.187	
18-0517	26-32911	1.100	1.260	0.127	
18-0519	26-14240	3.792	4.536	0.482	
18-0522	26-43036	1.045	1.474	0.187	
18-0523	26-43993	1.640	2.132	0.282	
18-0525	26-45587	0.390	0.628	0.124	
18-0526	26-48443	0.750	1.379	0.256	
18-0527	26-56397	0.750	1.127	0.343	
18-0529	26-62818	1.640	2.256	0.319	
18-0531	26-72785	0.790	1.880	0.248	
18-0537	26-85107	1.020	1.507	0.251	
18-0578	26-67388	1.800	3.100	0.500	
18-2002	26-76868, 26-70019	1.188	1.692	0.25	
18-2004	26-20070	0.625	1	0.25	
18-2003	26-32080, 26-68493, 26-823894	2.25	3	0.437	
18-2004	26-20070	0.625	1	0.25	
18-2006	26-897154	0.625	1.125	0.312	
18-2007	26-94038, 26-30727, 26-31489	1	1.5	0.312	
18-2008	26-56788	0.875	1.25	0.375	
18-2009	26-892361, 26-25776, 26-31249, 26-46021	0.375	0.75	0.25	
18-2010	26-897153	0.437	0.875	0.25	
18-2011	26-23300, 26-90562, 26-29595	0.75	1.25	0.312	

Part #	O.E. #	Shaft Size (in.)	Dimensions (in.)	
			O.D.	Width
18-2013	802276, 26-16977, 26-20465, 26-31507, 26-79884	0.875	1.25	0.188
18-2014	26-33144, 26-77634, 26-89238, 26-F694305	0.875	1.5	0.312
18-2015	20250, 26-23517	0.75	1.25	0.25
18-2016	26-20079, 26-25837, 26-29476, 26-41953	1.187	1.875	0.25
18-2017	26-32121, 26-35025	0.75	1	0.125
18-2019	26-27163	0.688	1.124	0.25
18-2026 ①	802276, 26-16977, 26-20465, 26-31507, 26-79884	0.875	1.25	0.188
18-2048	26-24590	0.4	0.566	0.094
18-2049	26-32511	1.25	2.005	0.388
18-2050	26-55682	1	1.253	0.125
18-2051	26-69188	0.875	1.253	0.278
18-2052	26-69189	0.875	1.314	0.322
18-2053	26-70081	1.185	1.754	0.36
18-2054	26-76384, 26-8164641	0.375	0.75	0.243
18-2055	26-21642, 26-26782, 26-79831	0.75	1.127	0.149
18-2056	26-37259, 26-89237, 26-96503, 26-965031	0.875	1.375	0.250
18-2076 ①	26-F697118, 26-12224	1.188	1.690	0.360
18-2077	26-F697555, 26-14077	1.188	1.689	0.247

① Line Cutter Seal

DRIVESHAFT HOUSING

Stern Drive Model	Beg. S/N	End S/N	Oil Seal	Desc.	Qty.
R/MR/Alpha I	6225577	UP	18-2003	BC	1
Alpha I SS		ALL	18-2003	BC	1
Alpha I SS		ALL	18-2056	LDS	1
Alpha I SS		ALL	18-2049	GC	1
IA,IB,IC	1684188	2065189	18-2003	BC	1
I,IA,IB,IC	1534570	2065189	18-2049	GC	1
IA,IB,IC	1749276	2065189	18-2056	LDS	1
II	1474909	2671321	18-2003	BC	1
120/140	2062141	6225576	18-2003	BC	1
120/140	2062141	6225576	18-2056	LDS	1
120/140	2062141	6225576	18-2049	GC	1
160/165	2065190	UP	18-2003	BC	1
160/165	2065190	UP	18-2049	GC	1
160/165	2065190	UP	18-2056	LDS	1
225-S	3856268	4200499	18-2056	LDS	1
225-S	3856268	4200499	18-2049	GC	1
225-S	3856268	4200499	18-2003	BC	1
233	4200500	UP	18-2049	GC	1
233	4200500	UP	18-2003	BC	1
233	4200500	UP	18-2056	LDS	1

Stern Drive Model	Beg. S/N	End S/N	Oil Seal	Desc.	Qty.
250	4791300	4898729	18-2049	GC	1
250	4791300	4898729	18-2003	BC	1
250	4791300	4898729	18-2056	LDS	1
260	4898730	6225576	18-2049	GC	1
260	4898730	6225576	18-2056	LDS	1
260	4898730	6225576	18-2003	BC	1
470	4208730	6225576	18-2056	LDS	1
470	4208730	6225576	18-2003	BC	1
470	4208730	6225576	18-2049	GC	1
485	4893835	UP	18-2003	BC	1
485	4893835	UP	18-2049	GC	1
485	4893835	UP	18-2056	LDS	1
888	3106717	UP	18-2056	LDS	1
888	3106717	UP	18-2049	GC	1
888	3106717	UP	18-2003	BC	1
898/228	4782330	6225576	18-2049	GC	1
898/228	4782330	6225576	18-2003	BC	1
898/228	4782330	6225576	18-2056	LDS	1

BC Bearing Carrier Seal
GC Gear Chamber Seal
LDS Lower Driveshaft Seal

GEAR HOUSING

Stern Drive Model	Beg. S/N	End S/N	Oil Seal	Desc.	Qty.
MR/Alpha I	6225577	UP	18-2002	PS	2
R/MR/Alpha I	6225577	UP	18-2009	SSB	1
R/MR/Alpha I	6225577	UP	18-2014	WPB,L	1
MR/Alpha I	6225577	UP	18-2013	WPB,U	1
R	6225577	UP	18-2013	WPB,U	1
Alpha I SS	ALL		18-2014	WPB,L	1
Alpha I SS	ALL		18-2009	SSB	1

Stern Drive Model	Beg. S/N	End S/N	Oil Seal	Desc.	Qty.
Alpha I SS	ALL		18-2013	WPB,U	1
Alpha I SS	ALL		18-2002	PS	2
BRAVO I	B664190	UP	18-2002	PS	2
I	1534570	1536617	18-2009	WPB	1
I	1534570	1684187	18-2009	SSB	1
I	1534570	1684187	18-2002	PS	2
I	1534570	1684187	18-2013	WP	1

GEAR HOUSING (Cont.)

Stern Drive Model	Beg. S/N	End S/N	Oil Seal	Desc.	Qty.	Stern Drive Model	Beg. S/N	End S/N	Oil Seal	Desc.	Qty.
I	1536618	1684187	18-2014	WPB	1	233	4200500	UP	18-2009	SSB	1
I	1563354	1684187	18-2013	WPB	1	233	4200500	UP	18-2013	WPB,U	1
IA,IB,IC	1684188	2065189	18-2014	WPB	1	233	4200500	UP	18-2002	PS	2
IA,IB,IC	1684188	2065189	18-2002	PS	2	233	4200500	UP	18-2014	WPB,L	1
IA,IB,IC	1684188	2065189	18-2013	WPB	1	250	4791300	4898729	18-2013	WPB,U	1
IA,IB,IC	1684188	2065189	18-2013	WP	1	250	4791300	4898729	18-2014	WPB,L	1
IA,IB,IC	1684188	2065189	18-2009	SSB	1	250	4791300	4898729	18-2002	PS	2
TRS	4794900	UP	18-2002	PS	2	250	4791300	4898729	18-2009	SSB	1
60	1830753	2063740	18-2009	SSB	1	255-TRS	3377316	4203749	18-2002	PS	2
60	1830753	2063740	18-2011	WPB,L	1	260	4898730	6225576	18-2009	SSB	1
60	1830753	2063740	18-2055	WPB,U	1	260	4898730	6225576	18-2002	PS	2
60	1830753	2063740	18-2015	PS,O	1	260	4898730	6225576	18-2013	WPB,U	1
60	1830753	2063740	18-2011	PS,I	1	260	4898730	6225576	18-2014	WPB,L	1
80	2063741	2898029	18-2002	PS	2	280-TRS	4203750	4895399	18-2002	PS	2
80	2063741	2898029	18-2009	SSB	1	470	4208730	6225576	18-2009	SSB	1
80	2063741	2898029	18-2055	WPB,U	1	470	4208730	6225576	18-2014	WPB,L	1
80	2063741	2898029	18-2011	WPB,L	1	470	4208730	6225576	18-2002	PS	2
90	2898020	3225967	18-2009	SSB	1	470	4208730	6225576	18-2013	WPB,U	1
90	2898020	3225967	18-2002	PS	2	485	4893835	UP	18-2002	PS	2
90	2898020	3225967	18-2011	WPB,L	1	485	4893835	UP	18-2009	SSB	1
90	2898020	3225967	18-2055	WPB,U	1	485	4893835	UP	18-2013	WPB,U	1
120/140	2062141	6225576	18-2013	WPB,U	1	485	4893835	UP	18-2014	WPB,L	1
120/140	2062141	4893634	18-2013	WP	1	888	3106717	UP	18-2014	WPB,L	1
120/140	2062141	6225576	18-2014	WPB,L	1	888	3106717	UP	18-2009	SSB	1
120/140	2062141	6225576	18-2009	SSB	1	888	3106717	UP	18-2013	WP	1
120/140	2062141	6225576	18-2002	PS	2	888	3106717	UP	18-2013	WPB,U	1
160/165	2065190	UP	18-2009	SSB	1	888	3106717	UP	18-2002	PS	2
160/165	2065190	UP	18-2014	WPB,L	1	898/228	4782330	6225576	18-2014	WPB,L	1
160/165	2065190	UP	18-2002	PS	2	898/228	4782330	6225576	18-2013	WPB,U	1
160/165	2065190	4890459	18-2013	WP	1	898/228	4782330	6225576	18-2009	SSB	1
160/165	2065190	UP	18-2013	WPB,U	1	898/228	4782330	6225576	18-2002	PS	2
225-S	3856268	4200499	18-2013	WPB,U	1						
225-S	3856268	4200499	18-2014	WPB,L	1						
225-S	3856268	4200499	18-2002	PS	2						
225-S	3856268	4200499	18-2009	SSB	1						

PS Prop Shaft Seal
 PS,I Prop Shaft, Inner Seal
 PS,O Prop Shaft, Outer Seal
 SSB Shift Shaft Bushing Seal
 WPB Water Pump Base Seal
 WPB,L Water Pump Base, Lower Seal
 WPB,U Water Pump Base, Upper Seal
 WP Water Pump Body Seal

O-RINGS

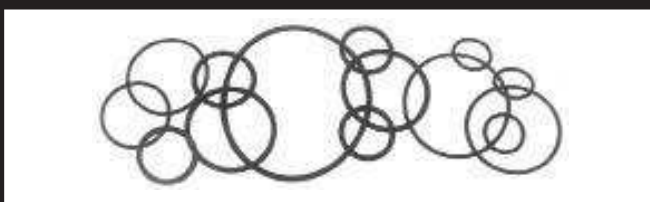

Part #	O.E. #	DIMENSIONS (in.)	
		O.D.	Width
18-0175 ③ ⑤	25-26543	0.22	0.103
18-0858 ③ ⑤	25-54029	2.8	0.103
18-0860 ③ ⑤	25-62700	3.237	0.103
18-7103 ②	25-29845	0.924	0.103
18-7105 ④ ⑤	25-62705, 25-F7848342	0.75	0.065
18-7107 ② ⑤	25-67202	4.75	0.135
18-7114 ② ⑤	25-23145, 25-843315, 25-F702736	1	0.135
18-7115 ①	25-26722	1.735	0.135
18-7116 ①	25-62704, 25-85148, 25-22174, 25-20633, 802206, 25-F24342	0.36	0.1
18-7117 ②	25-35027	1.046	0.139
18-7120 ①	25-38933	0.215	0.065
18-7121 ①	25-35029, 25-882613, 802231	3.1	0.135
18-7127 ①	25-32507, F83404	3.315	0.35
18-7134 ②	25-20195, 25-201951	0.5	0.1

Part #	O.E. #	DIMENSIONS (in.)	
		O.D.	Width
18-7135 ①	25-20365, 25-35276	0.75	0.135
18-7143 ② ⑤	27-58025, 25-65936, 391-5081	1.31	0.1
18-7145 ② ⑤	25-64068	0.25	0.1
18-7146 ② ⑤	25-47632	1.12	0.1
18-7151 ② ⑤	25-20081, 25-39572	3	0.135
18-7152 ② ⑤	25-20863	2.625	0.135
18-7153 ② ⑤	25-25439, 25-20679, 25-F53795-1, F53795	0.862	0.103
18-7155 ② ⑤	25-26855	1.62	0.135
18-7156 ② ⑤	25-29439	1.185	0.1
18-7157 ② ⑤	25-29976	3.5	0.21
18-7158 ② ⑤	25-30613, 25-846357	0.74	0.1
18-7159 ② ⑤	25-31534, 25-48451	3.855	0.21
18-7160 ② ⑤	25-31986	2.635	0.21
18-7161 ② ⑤	25-32546	3.25	0.07
18-7162 ② ⑤	25-32424, 25-33145	2.025	0.135
18-7163 ② ⑤	25-33465, 25-853220, 25-807149	2.415	0.1
18-7164 ② ⑤	25-33466, 25-67675, 25-846356, 27-898101789	1.375	0.1
18-7165 ② ⑤	25-32509, 25-806609, 25-F461342	0.5	0.065
18-7166 ② ⑤	25-45254	0.615	0.065

CONTINUED ON NEXT PAGE

① PKG. OF 1 ② PKG. OF 5 ③ PKG. OF 2 ④ PKG. OF 3

O-RINGS (CONT.)

Part #	O.E. #	DIMENSIONS (in.)		Part #	O.E. #	DIMENSIONS (in.)	
		O.D.	Width			O.D.	Width
18-7167 ② ⑤	25-861844	3.609	0.139	18-7411 ② ⑤	25-35480, 25-47386, 25-8M2000816	1.25	0.1
18-7168 ② ⑤	25-20587, 25-21720, 25-26834, 25-48171, 25-801334436	0.37	0.065	18-7413 ② ⑤	22-22175, 25-62702, 25-F50342-1, F50342, F17510	0.301	0.07
18-7169 ② ⑤	25-35984, 25-70937	3.5	0.135	18-7414 ② ⑤	25-823683, 25-62384	1.989	0.07
18-7170 ② ⑤	25-33504	1.365	0.135	18-7415 ② ⑤	25-64966	3.739	0.07
18-7171 ② ⑤	25-30529	1.92	0.1	18-7419 ④ ⑤	25-69202	2.675	0.103
18-7172 ② ⑤	25-31305	3.25	0.135	18-7420 ③ ⑤	25-21836	0.796	0.139
18-7173 ② ⑤	25-27018, 25-30224Q	1.875	0.135	18-7421 ① ⑤	25-16524	0.15	0.065
18-7174 ② ⑤	25-45711, 25-F455342	0.62	0.1	18-7426 ③ ⑤	25-30271	0.74	0.31
18-7175 ② ⑤	25-62817	3.75	0.27	18-7440-1 ③	25-36318	0.799	0.103
18-7176 ② ⑤	25-896523, 25-F74305, F74305-1, F74305, F694555	2.16	0.1	18-7445 ③ ⑤	25-55801	0.801	0.07
18-7177 ② ⑤	25-53421, 25-59712	2.625	0.065	18-7449 ①	25-97387	4.487	0.103
18-7180 ③ ⑤	12-31060, 25-26802, 25-8M2000926	0.445	0.09	18-7459 ①	20311, 25-20826	2.234	0.139
18-7188 ②	25-805726	0.361	0.0635	18-7464 ①	25-39695, 25-846361	4.234	0.139
18-7195 ②	25-8M0027717	2.75	0.07	18-7467 ③ ⑤	25-54030, 25-F523555, F532555	2.987	0.103
18-7198 ② ⑤	25-45710	1.43	0.1	18-7474 ①	25-94288	1.239	0.07
18-7410 ② ⑤	25-36390	0.676	0.07	18-7961 ①	25-47254, 25-861844, 785-97386	3.65	0.135

① PKG. OF 1 ② PKG. OF 5 ③ PKG. OF 2 ④ PKG. OF 3

DRIVESHAFT HOUSING

Stern Drive Model	Beg. S/N	End S/N	Oil Seal	Desc.	Qty.	Stern Drive Model	Beg. S/N	End S/N	Oil Seal	Desc.	Qty.
R/MR/Alpha I	6225577	UP	18-7153	UJ	2	215E □	2909035	2915034	18-7174	FC	1
R/MR/Alpha I	6225577	UP	18-7169	BC	1	215E	2909035	2915034	18-7146	CC	1
R/MR/Alpha I	6225577	UP	18-7161	TC	1	225-S	3856268	4200499	18-7153	UJ	2
Alpha I SS	ALL		18-7161	TC	1	225-S	3856268	4200499	18-7169	BC	1
Alpha I SS	ALL		18-7169	BC	1	225-S	3856268	4200499	18-7161	TC	1
Alpha I SS	ALL		18-7153	UJ	2	233	4200500	UP	18-7161	TC	1
BRAVO (I/II)	B664190	UP	18-7198	DSH	1	233	4200500	UP	18-7153	UJ	2
BRAVO (I/II)	B664190	UP	18-7153	UJ	2	233	4200500	UP	18-7169	BC	1
I	1534570	1684187	18-7127	DG	1	250	4791300	4898729	18-7153	UJ	2
I,IA,IB,IC	1534570	1777798	18-7165	USSL	1	250	4791300	4898729	18-7169	BC	1
I,IA,IB,IC	1535212	2065189	18-7170	BH	2	250	4791300	4898729	18-7161	TC	1
IA,IB,IC	1684188	2065189	18-7153	UJ	2	255-TRS	3377316	4203749	18-7175	DSH	1
IA,IB,IC	1684188	2065189	18-7169	BC	1	260	4898730	6225576	18-7169	DG	1
II	2398798	2671321	18-7153	UJ	2	260	4898730	6225576	18-7161	TC	1
II SSM	ALL		18-7175	DSH	1	260	4898730	6225576	18-7170	BH	1
II SSM	ALL		18-7153	UJ	2	260	4898730	6225576	18-7153	UJ	2
II TR	3377316	4794899	18-7175	DSH	1	280-TRS	4203750	4895399	18-7175	DSH	1
III/III SSM	ALL		18-7115	FC	1	470	4208730	6225576	18-7169	BC	1
IV SSM □	ALL		18-7115	FC	1	470	4208730	6225576	18-7161	TC	1
V/IA/IB/IC	1534570	2065189	18-7161	TC	1	470	4208730	6225576	18-7153	UJ	2
TR/TRS ③	4794900	UP	18-7153	UJ	2	470	4893835	6225576	18-7170	BH	1
TR/TRS	4794900	UP	18-7175	DSH	1	485	4893835	UP	18-7161	TC	1
120/140	2062141	6225576	18-7161	TC	1	485	4893835	UP	18-7170	BH	1
120/140	2062141	6225576	18-7170	BH	1	485	4893835	UP	18-7153	UJ	2
120/140	2062141	6225576	18-7169	DG	1	485	4893835	UP	18-7169	DG	1
120/140	2062141	6225576	18-7153	UJ	2	888	3106717	UP	18-7161	TC	1
160/165	2065190	UP	18-7170	BH	1	888	3106717	UP	18-7169	BC	1
160/165	2065190	UP	18-7169	DG	1	888	3106717	UP	18-7153	UJ	2
160/165	2065190	UP	18-7153	UJ	2	898/228	4782330	6225576	18-7169	BC	1
160/165	2065190	UP	18-7161	TC	1	898/228	4782330	6225576	18-7161	TC	1
215H	2782203	2909034	18-7153	UJ	2	898/228	4782330	6225576	18-7153	UJ	2
215H	2782203	2909034	18-7146	PC	1	898/228	4898730	6225576	18-7170	BH	1

① 1 ST Design
 ② 5/8" ID
 ③ With Borg Warner Transmission
 BC Bearing Carrier Seal
 BH Bell Housing Seal
 CC Crankshaft Cover Seal
 DG Drive Gear Seal

DSH Driveshaft Housing Seal
 FC Front Cover Seal
 PC Plug Cover Seal
 TC Top Cover Seal
 USSL Upper Shift Shaft Lever Seal
 UJ U-Joint Yoke Seal

GEAR HOUSING

Stern Drive Model	Beg. S/N	End S/N	Oil Seal	Desc.	Qty.	Stern Drive Model	Beg. S/N	End S/N	Oil Seal	Desc.	Qty.
R/MR/Alpha I	6225577	UP	18-7162	WPB	1	160/165	2065190	UP	18-7158	UDS	1
MR/Alpha I	6225577	UP	18-7176	WPB	1 ②	160/165	2065190	UP	18-7159	PBH	1
R/MR/Alpha I	6225577	UP	18-7158	UDS	1	165	4890460	UP	18-7114	GH	1 ③
R/MR/Alpha I	6225577	UP	18-7159	PBH	1	225-S	3856268	4200499	18-7153	SSB	1
R/MR/Alpha I	6225577	UP	18-7153	SSB	1	225-S	3856268	4200499	18-7162	WPB	1
Alpha I SS	ALL		18-7159	PBH	1	225-S	3856268	4200499	18-7158	UDS	1
Alpha I SS	ALL		18-7158	UDS	1	225-S	3856268	4200499	18-7159	PBH	1
Alpha I SS	ALL		18-7153	SSB	1	233	4200500	UP	18-7162	WPB	1
Alpha I SS	ALL		18-7176	WPB	1 ②	233	4200500	UP	18-7158	UDS	1
BRAVO I	B664190	UP	18-7159	PBH	1	233	4200500	UP	18-7159	PBH	1
BRAVO I/II	B664190	UP	18-7163	GH	1	233	4200500	UP	18-7153	SSB	1
I	1534570	1684187	18-7157	PBH	1	250	4791300	4898729	18-7159	PBH	1
I	1534570	1536617	18-7153	WPB	1	250	4791300	4898729	18-7158	UDS	1
I	1534570	1684187	18-7153	SSB	1	250	4791300	4898729	18-7162	WPB	1
I,IA,IB,IC	1534570	2065189	18-7158	UDS	1	250	4791300	4898729	18-7153	SSB	1
I,IA,IB,IC	1536618	2065189	18-7162	WPB	1	255-TRS	3377316	4203749	18-7159	PBH	1
IA,IB,IC	1684188	2065189	18-7159	PBH	1	260	4898730	6225576	18-7162	WPB	1
IA,IB,IC	1684188	1777798	18-7153	WPB	1	260	4898730	6225576	18-7159	PBH	1
IA,IB,IC	1684188	2065189	18-7153	SSB	1	260	4898730	6225576	18-7153	SSB	1
II	1474909	2671321	18-7159	PBH	1	260	4898730	6225576	18-7158	UDS	1
III	ALL		18-7151	BRL	1	260	4898730	6225576	18-7114	GH	1 ③
III	ALL		18-7174	BRS	1	280-TRS	4203750	4895399	18-7159	PBH	1
TRS	4794900	UP	18-7159	PBH	1	470	4208730	6225576	18-7159	PBH	1
60	1830753	2063740	18-7153	SSB	1	470	4208730	6225576	18-7162	WPB	1
60	1830753	2063740	18-7160	PBH	1	470	4208730	6225576	18-7158	UDS	1
60	1830753	2063740	18-7155	WOAL	1	470	4208730	6225576	18-7153	SSB	1
60	1830753	2063740	18-7114	WOAS	1	470	4893835	6225576	18-7114	GH	1 ①
80	2063741	2898029	18-7157	PBH	1	485	4893835	UP	18-7158	UDS	1
80	2063741	2898029	18-7155	WOAL	1	485	4893835	UP	18-7162	WPB	1
80	2063741	2898029	18-7114	WOAS	1	485	4893835	UP	18-7153	SSB	1
80	2063741	2898029	18-7153	SSB	1	485	4893835	UP	18-7114	GH	1 ①
90	2898020	3225967	18-7114	WOAS	1	485	4893835	UP	18-7159	PBH	1
90	2898020	3225967	18-7157	PBH	1	888	3106717	UP	18-7162	WPB	1
90	2898020	3225967	18-7153	SSB	1	888	3106717	UP	18-7158	UDS	1
90	2898020	3225967	18-7155	WOAL	1	888	3106717	UP	18-7153	SSB	1
120/140	2062141	6225576	18-7153	SSB	1	888	3106717	UP	18-7159	PBH	1
120/140	2062141	6225576	18-7158	UDS	1	898/228	4782330	6225576	18-7158	UDS	1
120/140	2062141	6225576	18-7159	PBH	1	898/228	4782330	6225576	18-7153	SSB	1
120/140	2062141	6225576	18-7162	WPB	1	898/228	4782330	6225576	18-7159	PBH	1
120/140	4893635	6225576	18-7114	GH	1 ③	898/228	4782330	6225576	18-7162	WPB	1
160/165	2065190	UP	18-7162	WPB	1	898/228	4898730	6225576	18-7114	GH	1 ①
160/165	2065190	UP	18-7153	SSB	1						

- ① 2.019 ID
- ② 2.17 ID
- ③ V-8 Engines Only
- BRL Bearing Retainer Large Seal
- BRS Bearing Retainer Small Seal
- GH Gear Housing Seal

- PGH Prop Bearing Housing Seal
- SSB Shift Shaft Bushing
- UDS Upper Driveshaft Seal
- WOAL Water & Oil Adapter Large Seal
- WOAS Water & Oil Adapter Small Seal
- WPB Water Pump Base Seal

GIMBAL HOUSING

Stern Drive Model	Beg. S/N	End S/N	Oil Seal	Desc.	Qty.	Stern Drive Model	Beg. S/N	End S/N	Oil Seal	Desc.	Qty.
R/MR/Alpha I	6225577	UP	18-7170	BH	1	II	1602186	2671321	18-7162	GHAS	1
BRAVO (I/II)	B664190	UP	18-7168	V	2 ①	II	1732380	2671321	18-7172	GHAL	1
I	1534570	1641940	18-7165	GHB	2	III/III SSM/IV		ALL	18-7159	BH	1
II	1474909	1475005	18-7151	SL	1	60	1830753	2063740	18-7172	BH	1

- ① With Oil Reservoir
- BH Bell Housing Seal
- EE Exhaust Elbow Seal
- GH Gimbal Housing Seal
- GHAL Gimbal Housing Adapter Large Seal

- GHAS Gimbal Housing Adapter Small Seal
- GHB Gimbal Housing Bolt Seal
- SL Steering Lever Seal
- V Valve Seal

⑤ This product is priced per piece. To order priced per package, please add -9 to the part number.

GIMBAL HOUSING (CONT.)

Stern Drive Model	Beg. S/N	End S/N	Oil Seal	Desc.	Qty.
80	2063741	2898029	18-7172	BH	1
90	2898020	3225967	18-7172	BH	1
120/140	2062141	6225576	18-7152	EE	1
160/165	2065190	UP	18-7152	EE	1
225-S	3856268	4200499	18-7170	BH	1
225-S	3856268	4200499	18-7152	EE	1
225-S	3856268	4200499	18-7114	GH	1
233	4200500	UP	18-7152	EE	1
233	4200500	UP	18-7114	GH	1
233	4200500	UP	18-7170	BH	1
250	4791300	4898729	18-7152	EE	1
250	4791300	4898729	18-7114	GH	1
250	4791300	4898729	18-7170	BH	1
260	4898730	6225576	18-7152	EE	1
470	4208730	6225576	18-7152	EE	1

Stern Drive Model	Beg. S/N	End S/N	Oil Seal	Desc.	Qty.
470	4208730	4893934	18-7170	BH	1
485	4893835	UP	18-7152	EE	1
888	3106717	UP	18-7170	BH	1
888	3106717	UP	18-7114	GH	1
888	3106717	UP	18-7152	EE	1
898/228	4782330	4898729	18-7170	BH	1
898/228	4782330	4898729	18-7114	GH	1
898/228	4782330	6225576	18-7152	EE	1

- ① With Oil Reservoir
- BH Bell Housing Seal
- EE Exhaust Elbow Seal
- GH Gimbal Housing Seal
- GHAL Gimbal Housing Adapter Large Seal
- GHAS Gimbal Housing Adapter Small Seal
- GHB Gimbal Housing Bolt Seal
- SL Steering Lever Seal
- V Valve Seal

HYDRAULIC PUMP ASSY

Stern Drive Model	Beg. S/N	End S/N	Oil Seal	Desc.	Qty.
R/MR/Alpha I	6225577	UP	18-7168	CV	4
BRAVO (I/II)	B664190	UP	18-7134	ORC	1
BRAVO (I/II)	B664190	UP	18-7158	ORS	1
II	2398798	2671321	18-7168	CV	4
II TR	3377316	4794899	18-7168	CV	4
III/III SSM/IV		ALL	18-7168	CV	4
TR/TRS	4794900	UP	18-7168	CV	4
90	2898020	3225967	18-7168	CV	4
120/140	2062141	6225576	18-7168	CV	4
160/165	2065190	UP	18-7168	CV	4

Stern Drive Model	Beg. S/N	End S/N	Oil Seal	Desc.	Qty.
215H/E	2782203	2915034	18-7168	CV	4
225-S	3856268	4200499	18-7168	CV	4
233	4200500	UP	18-7168	CV	4
255-TRS	3377316	4203749	18-7168	CV	4
260	4898730	6225576	18-7168	CV	4
280-TRS	4203750	4895399	18-7168	CV	4
470	4208730	6225576	18-7168	CV	4
485	4893835	UP	18-7168	CV	4
888	3106717	UP	18-7168	CV	4
898/228	4898730	6225576	18-7168	CV	4

CV - Control Valve ORC - Oil Reservoir Connector ORS - Oil Reservoir Switch

REVERSE LOCK VALVE

Stern Drive Model	Beg. S/N	End S/N	Oil Seal	Desc.	Qty.
R/MR/Alpha I	6225577	UP	18-7174	VC	1
R/MR/Alpha I	6225577	UP	18-7198	V	1
II	2398798	2671321	18-7198	V	1
II	2398798	2671321	18-7174	VC	1
120/140	2062141	6225576	18-7198	V	1
120/140	2062141	6225576	18-7174	VC	1
160/165	2065190	UP	18-7198	V	1
160/165	2065190	UP	18-7174	VC	1
250	4791300	4898729	18-7198	V	1

Stern Drive Model	Beg. S/N	End S/N	Oil Seal	Desc.	Qty.
250	4791300	4898729	18-7174	VC	1
260	4898730	6225576	18-7198	V	1
260	4898730	6225576	18-7174	VC	1
470	4208730	6225576	18-7198	V	1
470	4208730	6225576	18-7174	VC	1
485	4893835	UP	18-7174	VC	1
485	4893835	UP	18-7198	V	1
898/228	4782330	6225576	18-7174	VC	1
898/228	4782330	6225576	18-7198	V	1

V - Valve Seal VC - Valve Cover Seal

