

Johnson/Evinrude Model Identification

Outboards 1980-1998

Model Variation	Style	Horse-power	Design Feature	Shaft Year Length	Built
A = Australia B = Belgium C = Canada H = Hong Kong S = South Africa T = Tracker V = Boat Builder	J = Johnson E = Evinrude C = Commercial V = Quiet Rider	Example: 20 40 200	AE = Elec. Start - Alaska AR = Rope Start - Alaska BA = AC Lighting - Rope Start BE = Belgium Derated - Elec. Start BF = Belgium Derated - Rope Start BG = Belgium Derated - Rope Start BI = Belgium Derated - Rope Start BR = Euro Rope Start C = Counter Rotation CE = Canada Derated - Elec. Start CR = Canada Derated - Rope Start D = Remote Electric DE = Derated - Elec. Start DR = Derated - Rope Start DT = Derated - Elec. Start/Trim & Tilt E = Elec. Start ER = Elec. Start - Sport Styling ES = Elec. Start - Special FA = 4-stroke - Rope Start FE = 4-stroke - Elec. Start/Remote FP = Commercial w/Program Tilt FR = 4-stroke - Rope Start FRE = 4-stroke - Elec. Start/Remote FS = FICHT - Trim & Tilt FT = FICHT - Trim & Tilt/Special Styling G = Special Styling H = Less Integral Tank/Hydraulic Steering I = FICHT Fuel Injection IE = Italy Elec. Start IK = Italy Elec. Start J = Jet Drive K = 3-CYL 25/35 KC = Kerosene Rope Start KG = Kerosene/Gasoline KS = Kerosene Rope Start M = Manual Tilt - Elec. Start MS = Manual Tilt - Elec. Start/Special N = Counter Rotation P = Power Steering Q = 3-CYL 25/35 Trim & Tilt R = Rope Start RA = Australia Rope Start RC = Rope Start - Commercial/CD Ignition RD = Rope Start - Deluxe RE = Remote Elec. RP = Commercial w/Program Tilt RS = Rope Start - Commercial RW = Commercial w/Program Tilt S = Sail - Special Styling SC = Special Styling/Counter Rotation SE = Elec. Start Non-Tilt Sail SI = Italy Special Derated SL = 60 Degree V - Trim & Tilt SP = Special Styling SR = Rope Start - Sail - Non-Tilt ST = Special Styling - Trim & Tilt T = Trim & Tilt - Elec. Start TE = Tiller Elec. TR = Trim & Tilt - Sport styling TT = Tiller - Trim & Tilt U = Manual Tilt V = Special Gearcase W = 110 Degree Angle Drive - Rope Start WM = Elec. Commercial - Manual Tilt WMP = Same as "WM" w/Chrome Pump WT = Elec. Commercial - Trim & Tilt WTP = Same as "WT" w/Chrome Pump	= 15" L = 20" Y = 22.5" X = 25" Z = 30"	I = 1 N = 2 T = 3 R = 4 O = 5 D = 6 U = 7 C = 8 E = 9 S = 0 EX: CS = 1980 ES = 1990 EU = 1997 SC = 2008

EXAMPLE: VE70TLEDA - Boat Builder Model, Evinrude, 70 HP, Trim & Tilt w/Elec. Start, 1996 Model







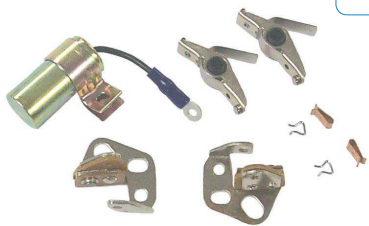

MODEL IDENTIFICATION CHART CONTINUED ON NEXT PAGE

Johnson/Evinrude Model Identification

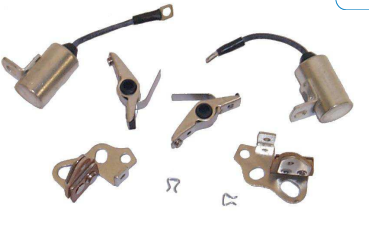
Outboards 1999 and Newer

Style	Horse-power	Design Feature	Shaft Length	Year Built
J = Johnson E = Evinrude	Example: 20 40 200	3 = 3-CYL (25 or 35 HP) 4 = Four Stroke Engine B = Blue Paint C = Counter-Rotation w/Trim & Tilt D = E-TEC E = Electric Start w/Remote Steering F = FICHT Fuel Injection G = Graphite Paint J = Jet M = Military Model P = Power Trim & Tilt R = Rope Start w/Tiller Steering S = Special Styling (White Evinrude) T = Tiller Steering TE = Tiller Electric W = Commercial Model	= 15" L = 20" Y = 22.5" X = 25" Z = 30"	I = 1 N = 2 T = 3 R = 4 O = 5 D = 6 U = 7 C = 8 E = 9 S = 0 EX: EE = 1999 SC = 2008

EXAMPLE: E70PLEEA - Evinrude model, 70 HP, Power Trim&Tilt, 20", 1999 model

<p style="text-align: center;">①18-5001D Display Package</p>  <p>18-5001 TUNE-UP KIT Replaces: 172525</p> <table style="width: 100%; border-collapse: collapse;"> <thead> <tr> <th colspan="4" style="text-align: center;">— CONTAINS —</th> </tr> <tr> <th style="text-align: left;">Part #</th> <th style="text-align: left;">Desc.</th> <th style="text-align: left;">O.E.#</th> <th style="text-align: left;">Qty.</th> </tr> </thead> <tbody> <tr> <td>18-5200</td> <td>Condenser</td> <td>580256</td> <td>1</td> </tr> <tr> <td>18-5157</td> <td>Contact set</td> <td>580290</td> <td>2</td> </tr> </tbody> </table>	— CONTAINS —				Part #	Desc.	O.E.#	Qty.	18-5200	Condenser	580256	1	18-5157	Contact set	580290	2	<p style="text-align: center;">①18-5002D Display Package</p>  <p>18-5002 TUNE-UP KIT Replaces: 172523</p> <table style="width: 100%; border-collapse: collapse;"> <thead> <tr> <th colspan="4" style="text-align: center;">— CONTAINS —</th> </tr> <tr> <th style="text-align: left;">Part #</th> <th style="text-align: left;">Desc.</th> <th style="text-align: left;">O.E.#</th> <th style="text-align: left;">Qty.</th> </tr> </thead> <tbody> <tr> <td>18-5205</td> <td>Condenser</td> <td>581419</td> <td>2</td> </tr> <tr> <td>18-5156</td> <td>Contact Set</td> <td>580148</td> <td>2</td> </tr> </tbody> </table>	— CONTAINS —				Part #	Desc.	O.E.#	Qty.	18-5205	Condenser	581419	2	18-5156	Contact Set	580148	2	<p style="text-align: center;">①18-5003D Display Package</p>  <p>18-5003 TUNE-UP KIT Replaces: 172806</p> <table style="width: 100%; border-collapse: collapse;"> <thead> <tr> <th colspan="4" style="text-align: center;">— CONTAINS —</th> </tr> <tr> <th style="text-align: left;">Part #</th> <th style="text-align: left;">Desc.</th> <th style="text-align: left;">O.E.#</th> <th style="text-align: left;">Qty.</th> </tr> </thead> <tbody> <tr> <td>18-5205</td> <td>Condenser</td> <td>581419</td> <td>2</td> </tr> <tr> <td>18-5141</td> <td>Contact Set</td> <td>581207</td> <td>2</td> </tr> </tbody> </table>	— CONTAINS —				Part #	Desc.	O.E.#	Qty.	18-5205	Condenser	581419	2	18-5141	Contact Set	581207	2
— CONTAINS —																																																		
Part #	Desc.	O.E.#	Qty.																																															
18-5200	Condenser	580256	1																																															
18-5157	Contact set	580290	2																																															
— CONTAINS —																																																		
Part #	Desc.	O.E.#	Qty.																																															
18-5205	Condenser	581419	2																																															
18-5156	Contact Set	580148	2																																															
— CONTAINS —																																																		
Part #	Desc.	O.E.#	Qty.																																															
18-5205	Condenser	581419	2																																															
18-5141	Contact Set	581207	2																																															
<p style="text-align: center;">①18-5006D Display Package</p>  <p>18-5006 TUNE-UP KIT Replaces: 172522</p> <table style="width: 100%; border-collapse: collapse;"> <thead> <tr> <th colspan="4" style="text-align: center;">— CONTAINS —</th> </tr> <tr> <th style="text-align: left;">Part #</th> <th style="text-align: left;">Desc.</th> <th style="text-align: left;">O.E.#</th> <th style="text-align: left;">Qty.</th> </tr> </thead> <tbody> <tr> <td>18-5199</td> <td>Condenser</td> <td>580321</td> <td>2</td> </tr> <tr> <td>18-5156</td> <td>Contact Set</td> <td>580148</td> <td>2</td> </tr> </tbody> </table>	— CONTAINS —				Part #	Desc.	O.E.#	Qty.	18-5199	Condenser	580321	2	18-5156	Contact Set	580148	2	 <p>18-5011 TUNE-UP KIT Replaces: 172521</p> <table style="width: 100%; border-collapse: collapse;"> <thead> <tr> <th colspan="4" style="text-align: center;">— CONTAINS —</th> </tr> <tr> <th style="text-align: left;">Part #</th> <th style="text-align: left;">Desc.</th> <th style="text-align: left;">O.E.#</th> <th style="text-align: left;">Qty.</th> </tr> </thead> <tbody> <tr> <td>18-5199</td> <td>Condenser</td> <td>580321</td> <td>1</td> </tr> <tr> <td>18-5156</td> <td>Contact Set</td> <td>580148</td> <td>1</td> </tr> </tbody> </table>	— CONTAINS —				Part #	Desc.	O.E.#	Qty.	18-5199	Condenser	580321	1	18-5156	Contact Set	580148	1	 <p>18-5141 CONTACT SET Replaces: 581207</p>																
— CONTAINS —																																																		
Part #	Desc.	O.E.#	Qty.																																															
18-5199	Condenser	580321	2																																															
18-5156	Contact Set	580148	2																																															
— CONTAINS —																																																		
Part #	Desc.	O.E.#	Qty.																																															
18-5199	Condenser	580321	1																																															
18-5156	Contact Set	580148	1																																															
 <p>18-5156 CONTACT SET Replaces: 580148</p>	 <p>18-5157 CONTACT SET Replaces: 580290</p>	<p style="text-align: center;">CONDENSERS</p> <p>18-5199 Replaces: 580321</p> <p>18-5205 Replaces: 581419</p>	 <p>18-5200 CONDENSER Replaces: 580256</p>																																															

APPLICATION BEGINS ON NEXT PAGE

① Items ending in "D" are Display Packaged - Regular number is Non-Display

JOHNSON/EVINRUDE TUNE-UP KIT APPLICATION											
HP	Year Start	Year Stop	Contact Set	Condenser	Tune-Up Kit	HP	Year Start	Year Stop	Contact Set	Condenser	Tune-Up Kit
1.2	1986	1990	18-5156	18-5199	18-5011	25	1955	1955	18-5156	18-5199	18-5006
1.5	1968	1970	18-5156	18-5199	18-5011	25	1969	1976	18-5156	18-5205	18-5002
2	1971	1985	18-5156	18-5199	18-5011	28	1962	1964	18-5156	18-5205	18-5002
3	1952	1968	18-5156	18-5199	18-5006	30	1956	1956	18-5156	18-5199	18-5006
3	1989	1990	18-5156	18-5199	18-5006	33	1965	1970	18-5156	18-5205	18-5002
4	1969	1976	18-5156	18-5199	18-5006	35	1958	1959	18-5156	18-5199	18-5006
4	1981	1988	18-5156	18-5199	18-5006	35	1976	1976	18-5141	18-5205	18-5003
5	1965	1968	18-5156	18-5199	18-5006	38	1968	1968	18-5156	18-5199	18-5006
5.5	1954	1964	18-5156	18-5199	18-5006	40	1960	1961	18-5156	18-5199	18-5006
6	1965	1976	18-5156	18-5199	18-5006	40	1962	1973	18-5156	18-5205	18-5002
7.5	1956	1958	18-5156	18-5199	18-5006	40	1974	1976	18-5141	18-5205	18-5003
9.5	1964	1973	18-5156	18-5199	18-5006	40 Comm	1981	1983	18-5141	18-5205	18-5003
10	1950	1963	18-5156	18-5199	18-5006	50	1958	1959	18-5157	18-5200	18-5001
9.9	1970	1970	18-5156	18-5199	18-5006	60	1964	1967	18-5157	18-5200	18-5001
9.9	1974	1976	18-5141	18-5205	18-5003	75	1961	1967	18-5157	18-5200	18-5001
15	1956	1956	18-5156	18-5199	18-5006	80	1966	1967	18-5157	18-5200	18-5001
15	1974	1976	18-5141	18-5205	18-5003	90	1964	1965	18-5157	18-5200	18-5001
18	1956	1961	18-5156	18-5199	18-5006	90	1968	1968	18-5157	18-5200	18-5001
18	1962	1973	18-5156	18-5205	18-5002	100	1966	1966	18-5157	18-5200	18-5001
20	1968	1973	18-5156	18-5205	18-5002						

 <p>18-5163 IGNITION COIL Replaces: 581130, 763809</p>	 <p>18-5170 IGNITION COIL Replaces: 583740, 583298</p>	 <p>18-5172 IGNITION COIL Replaces: 581786, 502881</p>	 <p>18-5176 IGNITION COIL KIT Replaces: 582106, 582330 582366, 583737, 584561</p>
--	--	---	---

 <p>18-5179D IGNITION COIL Replaces: 582508</p>	 <p>18-5181D IGNITION COIL Replaces: 582995, 584477</p>	 <p>18-5192 IGNITION COIL Replaces: 581610, 582091, 502888</p>
--	---	---

 <p>18-5193 IGNITION COIL Replaces: 580740, 582382</p>	 <p>18-5194 IGNITION COIL Replaces: 582160, 584632, 502890, 581032</p>	 <p>18-5196 IGNITION COIL Replaces: 581407, 502880</p>
---	--	---

APPLICATION BEGINS ON NEXT PAGE
 ① Items ending in "D" are Display Packaged - Regular number is Non-Display

JOHNSON/EVINRUDE IGNITION COIL APPLICATION

HP	Year Start	Year Stop	Coil	Qty.	HP	Year Start	Year Stop	Coil	Qty.	HP	Year Start	Year Stop	Coil	Qty.
2	1971	1973	18-5181	1	20	1966	1972	18-5181	2	60	1980	1984	18-5176	2
2	1975	1985	18-5181	1	20	1973	1973	18-5163	1	60	1985	1987	18-5179	3
2	1995	2001	18-5179	1	20	1985	1987	18-5179	2	60	1988	1988	18-5176	3
2.5	1987	1988	18-5170	1	20	1988	1988	18-5176	2	60	1989	2001	18-5179	3
3	1955	1968	18-5181	2	20	1989	1998	18-5179	2	65	1972	1973	18-5194	3
3	1989	1990	18-5181	2	25	1951	1953	18-5181	2	65	1984	1984	18-5176	3
3	1991	1997	18-5170	1	25	1955	1955	18-5181	2	65	1985	1988	18-5179	3
3	1998	2001	18-5179	1	25	1969	1972	18-5181	2	65	1989	1990	18-5176	3
3	2003	2005	18-5179	1	25	1973	1976	18-5163	1	65	1991	2001	18-5179	3
3.3	1995	1997	18-5179	1	25	1973	1976	18-5172	2	70	1974	1975	18-5194	3
4	1969	1976	18-5181	2	25	1977	1984	18-5176	2	70	1979	1984	18-5176	3
4	1977	1980	18-5176	2	25	1985	1987	18-5179	2	70	1985	1987	18-5179	3
4	1981	1988	18-5181	2	25	1988	1988	18-5176	2	70	1988	1988	18-5176	3
4	1986	1987	18-5179	2	25	1989	2005	18-5179	2	70	1989	2001	18-5179	3
4	1987	2001	18-5170	1	28	1962	1964	18-5181	2	75	1975	1975	18-5194	3
4	1988	1988	18-5176	2	28	1986	1996	18-5179	2	75	1979	1984	18-5176	3
4	1989	1996	18-5179	2	28	1995	1998	18-5170	1	75	1985	1987	18-5179	3
4.5	1980	1983	18-5176	2	30	1956	1956	18-5181	2	75	1988	1988	18-5176	3
5	1965	1968	18-5181	2	30	1984	1984	18-5176	2	75	2000	2001	18-5170	2
5	1996	1998	18-5170	1	30	1985	1987	18-5179	2	85	1969	1972	18-5193	1
5	1997	2001	18-5179	2	30	1988	1988	18-5176	2	85	1973	1975	18-5194	3
5.5	1954	1964	18-5181	2	30	1989	2005	18-5179	2	85	1976	1977	18-5192	4
6	1965	1976	18-5181	2	30	1999	2001	18-5170	1	85	1978	1980	18-5176	4
6	1977	1979	18-5176	2	33	1965	1970	18-5181	2	85	1991	1995	18-5179	4
6	1984	1984	18-5176	2	35	1957	1959	18-5181	2	88	1987	1987	18-5179	4
6	1985	1990	18-5179	2	35	1976	1976	18-5172	2	88	1988	1988	18-5176	4
6	1991	2005	18-5170	1	35	1977	1984	18-5176	2	88	1989	1996	18-5179	4
6	1997	2001	18-5179	2	35	1986	1987	18-5179	2	90	1981	1984	18-5176	4
6	2003	2004	18-5179	2	35	1988	1988	18-5176	2	90	1985	1987	18-5179	4
7.5	1954	1958	18-5181	2	35	1989	1994	18-5179	2	90	1988	1988	18-5176	4
7.5	1980	1983	18-5176	2	35	1996	1996	18-5179	2	90	1989	1998	18-5179	4
8	1984	1984	18-5176	2	40	1960	1973	18-5181	2	90	1995	2006	18-5170	2
8	1985	1990	18-5179	2	40	1974	1974	18-5196	2	100	1971	1972	18-5193	1
8	1991	2005	18-5170	1	40	1975	1979	18-5172	2	100	1979	1980	18-5176	4
9.5	1964	1973	18-5181	2	40	1983	1983	18-5172	2	100	1984	1984	18-5176	4
9.9	1974	1976	18-5196	2	40	1984	1984	18-5176	2	100	1985	1997	18-5179	4
9.9	1977	1984	18-5176	2	40	1985	1987	18-5179	2	100	1988	1988	18-5176	4
9.9	1985	1992	18-5179	2	40	1988	1988	18-5176	2	100	1998	2001	18-5170	2
9.9	1993	2001	18-5170	1	40	1989	2005	18-5170	1	105	1997	2001	18-5170	2
10	1949	1952	18-5181	2	40	1999	2001	18-5179	2	105	2003	2003	18-5170	2
10	1953	1953	18-5181	2	45	1986	1992	18-5179	2	110	1986	1987	18-5179	4
10	1954	1963	18-5181	2	45	1992	1997	18-5170	1	110	1988	1988	18-5176	4
10	2003	2007	18-5170	1	48	1987	1987	18-5179	2	110	1989	1989	18-5179	4
14	1988	1988	18-5179	2	48	1988	1988	18-5176	2	112	1994	1996	18-5179	4
14	1989	1989	18-5176	2	48	1989	1996	18-5170	1	115	1969	1970	18-5193	1
15	1953	1953	18-5181	2	50	1971	1975	18-5194	2	115	1973	1975	18-5194	4
15	1955	1956	18-5181	2	50	1979	1984	18-5176	2	115	1976	1977	18-5192	4
15	1965	1968	18-5181	2	50	1985	1987	18-5179	2	115	1978	1984	18-5176	4
15	1974	1976	18-5196	2	50	1988	1988	18-5176	2	115	1985	1985	18-5179	4
15	1977	1984	18-5176	2	50	1989	2005	18-5170	1	115	1990	1998	18-5179	4
15	1985	1992	18-5179	2	50	1995	1998	18-5179	2	115	1995	2006	18-5170	2
15	1993	2007	18-5170	1	55	1978	1984	18-5176	2	120	1985	1987	18-5179	4
18	1957	1972	18-5181	2	55	1985	1992	18-5179	2	120	1988	1988	18-5176	4
18	1973	1973	18-5163	1	55	1992	2005	18-5170	1	120	1989	1994	18-5179	4

APPLICATION CONTINUED ON NEXT PAGE

JOHNSON/EVINRUDE IGNITION COIL APPLICATION (Cont.)

HP	Year Start	Year Stop	Coil	Qty.	HP	Year Start	Year Stop	Coil	Qty.	HP	Year Start	Year Stop	Coil	Qty.
125	1971	1972	18-5193	1	150	1985	1991	18-5179	6	185	1989	1990	18-5179	6
125	1989	1990	18-5179	4	150	1988	1988	18-5176	6	185	1992	1994	18-5179	6
125	1992	1998	18-5179	4	150	1991	2006	18-5170	3	200	1976	1978	18-5192	6
130	1995	2001	18-5179	4	155	1984	1984	18-5176	6	200	1979	1983	18-5176	6
135	1973	1975	18-5194	4	155	1985	1985	18-5179	6	200	1986	2001	18-5179	6
135	1976	1976	18-5192	4	155	1987	1987	18-5179	6	200	1999	1999	18-5170	3
135	2000	2001	18-5170	2	155	1988	1988	18-5176	6	225	1986	2001	18-5179	6
140	1977	1977	18-5192	4	155	1989	1992	18-5179	6	225	1999	1999	18-5170	3
140	1978	1984	18-5176	4	175	1977	1978	18-5192	6	235	1978	1978	18-5192	6
140	1985	1987	18-5179	4	175	1979	1983	18-5176	6	235	1979	1984	18-5176	6
140	1988	1988	18-5176	4	175	1985	1991	18-5179	6	235	1985	1985	18-5179	6
140	1989	1994	18-5179	4	175	1991	2006	18-5170	3	250	1991	2001	18-5179	6
150	1978	1978	18-5192	6	185	1984	1984	18-5176	6	275	1985	1988	18-5179	6
150	1979	1984	18-5176	6	185	1985	1985	18-5179	6	300	1985	1995	18-5179	6



**18-5753
POWER PACK**
Replaces: 385391, 581731, 581311
(pack 4)



**18-5754
POWER PACK**
Replaces: 581726
(pack 3)



**18-5755
POWER PACK**
Replaces: 581397, 764708
(pack 2)



**18-5756
POWER PACK**
Replaces: 582056
Same as 18-5753 w/o Hardware Pack
(1) Hole Drilled



**18-5757
POWER PACK**
Replaces: 582057, 581713
Same as 18-5754 w/o Hardware Pack
(2) Holes Drilled



**18-5758
POWER PACK**
Replaces: 582453, 583380, 582452



**18-5759
POWER PACK**
Replaces: 582125, 581805



**18-5760
POWER PACK**
Replaces: 582138, 582400, 582642, 582556



**18-5761
POWER PACK**
Replaces: 583114



**18-5763
POWER PACK**
Replaces: 582285, 583170



**18-5764
POWER PACK**
Replaces: 582261, 586696



**18-5766
POWER PACK**
Replaces: 583748



18-5767
POWER PACK
Replaces: 584783



18-5768
POWER PACK
Replaces: 584908, 5001344

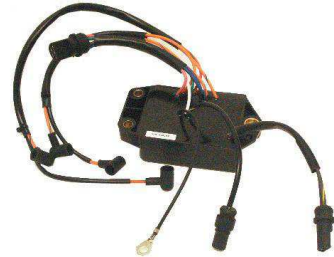

18-5770-1
POWER PACK
Replaces: 584028



18-5771
POWER PACK
Replaces: 584032



18-5772-1
POWER PACK
Replaces: 584041



18-5773
POWER PACK
Replaces: 584642, 763803



18-5774-1
POWER PACK
Replaces: 585145, 5004532



18-5780
POWER PACK
Replaces: 585189, 5004533



18-5781-1
POWER PACK
Replaces: 586661, 584636, 586212, 585114



18-5782
POWER PACK
Replaces: 582705, 763793



18-5783
POWER PACK
Replaces: 582811, 763794



18-5784-1
POWER PACK
Replaces: 583110



18-5785
POWER PACK
Replaces: 585261



18-5794
IGNITION MODULE
Replaces: 584489, 584329, 583896, 584331



18-5883
IGNITION MODULE
Replaces: 584488

APPLICATION BEGINS ON NEXT PAGE



**18-5885
POWER PACK**
Replaces: 583865
For: V-6 5800 rpm limit



**18-5886
POWER PACK & SENSOR**
Replaces: 436367, 584122
For: V6 engines with optical sensor and BLUE sleeve on power pack. Do not use with gray sleeved stator.



**18-5887
POWER PACK**
Replaces: 584985
For: V6 engines with optical sensor and GRAY sleeve on power pack. Do not use with black sleeved stator.



**18-5891
POWER PACK**
Replaces: 583605
For: 3 & 6 cyl. 6700 rpm limit



**18-5893
POWER PACK**
Replaces: 586667, 584037, 586217, 583476
For: V-4 & V-8 6700 rpm limit



**18-5884
OPTICAL SENSOR**
Replaces: 586343
For: V-4 & V-6 engines



**18-9802
TIMING LIGHT**
Self-powered accurate up to 10,000 RPM's

Model	Years	Power Pack	Model	Years	Power Pack	Model	Years	Power Pack
4	1977-80,1984	18-5758	25	1985	—	48	1987-88	18-5763
4	1993	18-5883	25	1986-88	18-5763	48	1991-93	18-5794
4 DLX	1986-88, 1994-99	18-5763	25	1989-92	18-5794	50	1971-75	18-5755
4.5	1980-84	18-5758	25	1993-95	18-5768	50	1979,1981-84	18-5758
4.5	1986-87	18-5763	25	1996-01	18-5768 ⑩	50	1985	—
5	1984	18-5758	25 COM.	1986-88	18-5764 ⑦	50	1986-88	18-5763
5	1985	—	28	1986-88	18-5763	50	1991-93	18-5794
5	1986-88, 1993-98	18-5763	28	1989-92	18-5794	50 Rope Start	1993- 01	18-5768
6	1977-79,1984	18-5758	28	1996-01	18-5768	50 Electric Start	1993- 01	18-5785
6	1985	—	30	1984	18-5758	50 (3 cyl)	1996-99	18-5780 ⑧
6	1986-88, 1993-01	18-5763	30	1985	—	55	1976-77	18-5755
6.5COM.	1992-99	18-5763	30	1986-88	18-5763	55	1978-82	18-5758
7.5	1980-83	18-5758	30	1989-92	18-5794	55	1991-92	18-5794
8	1993-95	18-5763	30	1993-95	18-5768	60	1970-71	—
9.9,15	1977-84	18-5758	30	1996-01	18-5768 ⑩	60	1980-84	18-5758
9.9,15	1985	—	35	1977-84	18-5758	60	1985	—
9.9,15	1986-88	18-5763	35	1985	—	60	1986-88	—
9.9,15	1993-99	18-5767 ②	35	1986-88	18-5763	60	1989-92	18-5766
14	1987	18-5763	35	1989-92	18-5794	60	1993-95	18-5774-1 ⑧
10/15COM.	1992	18-5763	35	1993-95	18-5768	60	1996-99	18-5780 ⑧
10,15COM.	1993-99	18-5767	40	1982	18-5758	65	1972-73	18-5754 ③
20	1981-84	18-5758	40	1985	—	65	1989-92	18-5766
20	1985	—	40	1986-88	18-5763	65	1993-95	18-5774-1 ⑧
20	1986-88	18-5763	40	1991-93	18-5794	70	1974-78	18-5754 ③
20	1989-92	18-5794	40 Rope Start	1993- 01	18-5768	70	1979-84	18-5760
20	1993-95	18-5768	40 Electric Start	1993- 01	18-5785	70	1985	18-5782 ⑧
20	1996-01	18-5768 ⑩	40 COM.	1986-88	18-5764	70	1986-88	—
25	1977-84	18-5758 ④	45	1991-92	18-5794	70	1989-92	18-5766

① 2 Power Packs required per engine
 ② Order 18-5756 for Power Pack w/o cover,insulated pad and mounting screws
 ③ Order 18-5757 for Power Pack w/o cover,insulated pad and mounting screws

④ All Models except Worktwin, Workhorse and Commercial Model for 1983
 ⑤ Port side only for 1983 model STLCT
 ⑥ Port side only for 1984 models with suffix beginning with "S"
 ⑦ 2 cyl. only

⑧ 3 cyl. only
 ⑨ Sea Drive Series
 ⑩ Except remote models
 ① Refer to picture
 ② For 2 stroke models only

APPLICATION CONTINUED ON NEXT PAGE

Model	Years	Power Pack	Model	Years	Power Pack	Model	Years	Power Pack
70	1993-95	18-5774-1 ⑧	110	1986-87	18-5784-1	185	1984	18-5760 ①
70	1996-99	18-5780 ⑧	110	1988	—	185	1990, 1992	18-5893
75	1975-78	18-5754 ③	115	1969-70	—	185	1993-99	18-5781-1
75	1979-84	18-5760	115	1973-77	18-5753 ②	200	1976-78	18-5754 ③ ①
75	1985	18-5782 ⑧	115	1978-84	18-5759 ①	200	1979-83	18-5760 ①
75	1986-88	—	115	1985	18-5783	200	1987	18-5891
85	1969-72	—	120	1986	—	200, 225	1988-92	18-5893
85	1973-77	18-5753 ②	120	1988-99	18-5772-1	200, 225	1993-99	18-5781-1
85	1978-80	18-5759 ①	125	1971-72	—	225	1987	18-5891
88, 90	1986-87	18-5784-1	130	1988-99	18-5772-1	235	1978	18-5754 ③ ①
88	1988	—	135	1973-76	18-5753 ②	235	1979-84	18-5760 ① ⑤ ⑥
88,90	1989-99 Crossflow	18-5770-1	140	1977	18-5753 ②	250	1991	18-5893
90	1981-83	18-5759 ①	140	1978-83	18-5759 ①	275	1986-87	—
90	1985	18-5783	140	1986	—	300	1987	—
90	1988	—	140	1988-99	18-5772-1	300	1991	18-5893
100	1971	—	150	197-78	18-5754 ③ ①	V-8	1993-99	18-5773
100	19,681,972	—	175	1979-83	18-5760 ①	1.6L	1984 & prior	18-5759 ⑨
100	1979-80	18-5759 ①	175	1986-88	18-5761	1.6L	1985	18-5782
100	1988	—	175	1989-91	18-5885	1.6L	1986-87	18-5784-1
100, 115	1989-99 Crossflow	18-5770-1	175	1991-92	18-5886 ①	2.0L	1988-99	18-5772-1
110 (TCLDF only)	1986	18-5783	175	1993-03	18-5887	2.5, 2.6L	1986-88	18-5761 ⑨













- ① 2 Power Packs required per engine
- ② Order 18-5756 for Power Pack w/o cover,insulated pad and mounting screws
- ③ Order 18-5757 for Power Pack w/o cover,insulated pad and mounting screws
- ④ All Models except Worktwin, Workhorse and Commercial Model for 1983
- ⑤ Port side only for 1983 model STLCT
- ⑥ Port side only for 1984 models with suffix beginning with "S"
- ⑦ 2 cyl. only
- ⑧ 3 cyl. only
- ⑨ Sea Drive Series
- ⑩ Except remote models
- ⑪ Refer to picture
- ⑫ For 2 stroke models only

PREMIUM MARINE SPARK PLUG WIRE LEADS

Sierra's MAGFORCE Ignition Wires are "Electronics Friendly" protecting all of your electronic devices and electronic engine controls from RFI and EMI while delivering the maximum amount of voltage. Exact fit design ensures easy installation and years of trouble - free service.



Part #	OEM #	Description	Part #	OEM #	Description
18-8815-1	OMC 582365	4" Spark Plug Wire	18-5230-9-1 ①③	Universal	10" Spark Plug Wire (pkg of 5)
18-8816-1	OMC 582365	6" Spark Plug Wire	18-8839-1	—	90 & 115 hp Outboard Wire Set Two - 14" • Two - 16"
18-5231-1	OMC 582365	9" Spark Plug Wire	18-8840-1	—	150 & 175 hp Outboard Wire Set Two - 14" • Two - 16"
18-5231-1D ②	OMC 582365	9" Spark Plug Wire	18-28090	—	V6 Outboard Plug Wire Set
18-8818-1	OMC 582365	12" Spark Plug Wire	18-28092	—	V4 Outboard Plug Wire Set
18-5229-9-1 ①③	Universal	22" Spark Plug Wire (pkg of 5)			

<p>PKG. OF 10</p>  <p>18-5224 18-5224-9^① SPARK PLUG WIRE TERMINAL Replaces: 510364</p>	 <p>18-5225 SPARK PLUG WIRE KIT Includes 25 ft Roll of Hypalon Ignition Wire with a copper conductor and a large assortment of three different end fittings to fit Johnson/Evinrude motors.</p>	 <p>18-5226 IGNITION WIRE (100' Spool) Hypalon Replaces: 510883, 772584</p>
<p>PKG. OF 10</p>  <p>18-5750 18-5750-9^① UNIVERSAL SPARK PLUG BOOTS Supplied complete w/ Terminal Connector Replaces: 581027, 580339</p>	 <p>18-5752 UNIVERSAL SPARK PLUG BOOT 8mm</p>	 <p>MP39100 IGNITION SWITCH Replaces: 386545 (5 Terminals - 3 Position)</p>
 <p>MP39760 IGNITION SWITCH Replaces: 393301, 508180 (6 Terminals - Push to Choke - 3 Position)</p>	 <p>MP39830 IGNITION SWITCH Replaces: 386545 (6 Terminals - Pistol Shaped Key - 3 Position) Pollak</p>	 <p>MP28890 IGNITION LANYARD Replaces: 176288 1996-Newer</p>
 <p>18-1282 LANYARD & CLIP Replaces: 398602 Tiller Steer Models - ALL</p>	 <p>MP28870 MP28872-1 (Bulk - 100 pc/carton) SWITCH & LANYARD Replaces: 585134</p>	 <p>MP28880 LANYARD Replaces: 432230 1995-older</p>
<p>① Priced per package ② Items ending in "D" are Display Packaged - Regular number is Non-Display ③ Uses 7mm copper core</p>		



DISPLAY PACKAGE

MP28900
MP28902-1 "Bulk"- 100 pieces per carton
LANYARD
Replaces: 432230
 1995-Older



18-5877
STATOR
Replaces: 584643, 763779
For: 185-300 HP Loopers (1993-2001)



18-5878
STATOR
Replaces: 584981, 763759
For: 150-175 HP (1993-2006)
 Gray Sleeve

JOHNSON/EVINRUDE STATOR APPLICATION

HP	Year Start	Year Stop	Stator
185	1993	1994	18-5877
200	1993	2001	18-5877
225	1993	2001	18-5877
250	1993	2001	18-5877
300	1993	1995	18-5877
150	1993	2006	18-5878
175	1993	2006	18-5878



18-6277
TILT/TRIM ASSEMBLY
Replaces: 435548
Heavy Duty, 2 Wire Connection, Flat Blade Shaft
(O-ring included)
Fits: OMC V6(1993), Commercial V8 (1993-Up)



18-6823
WIRING HARNESS
Replaces: Universal
Converts 3-wire Tilt and Trim motors to 2-Wire design



18-6280
TILT/TRIM ASSEMBLY
Replaces: 437801
Heavy Duty, OMC J Suffix 40,48,50HP(1992-Up)w/ 2 Wire Connection and Hollow Hex Shaft
(O-ring included)



18-6281
TILT/TRIM MOTOR
Replaces: 438786, 439937, 5005254
(O-ring included)
Plastic housing
Heavy Duty for OMC Outboards 75HP-250HP EFI(1998-Up)



18-6285
TILT/TRIM ASSEMBLY
Replaces: 433226
(O-ring included)
Heavy Duty OMC (1989-92) M Suffix 40,48,50HP w/ 2 Wire Connection and Hollow Hex Shaft



18-6756
TILT/TRIM MOTOR
Replaces: 172588, 173944
Fits: (1982-98) 2 cylinder 2 stroke engines that have been fitted with tilt kit 173946.



18-6759
TILT/TRIM MOTOR
Replaces: 394176, 391264, 393988, 985237
Newer 2 wire design for most 3, 4, 6 and 8 cyl. applications 1982 to present. 3 bolt.
(MOTOR ONLY)
Use 18-7510 O-ring (O-ring included)
Replaces: 321163



18-6761
TILT/TRIM MOTOR
Replaces: 387277, 582048, 582155, 584107
(O-ring included)
Older 3 wire design for most 3, 4, 6 cylinder outboards up to 1981
(Motor Only)



18-6762
TILT/TRIM MOTOR
Replaces: 172543
For most 85, 115 & 135 hp V-4 applications (Motor and Reservoir)



18-6767-1
TILT/TRIM MOTOR
Replaces: 172850, 173564, 173596
For: 1974 (115 & 135 HP)
For most 45 hp commercial models 1989-90, 2 cylinder applications (1984-88), 3 cylinder applications (1977-83) and 4 cylinder applications (1974-77)
(Motor and Reservoir)
For Repair Kit use 18-6252



18-6780
TILT/TRIM MOTOR
Replaces: 438529, 438531, 434496
For: 90, 115, 200, 225 HP (1991-Up); 120, 140 HP (1991-94); 130 HP (1995-Up)



18-6815
TRIM MOTOR
Replaces: Johnson/Evinrude
Fits: 2004-09 40-50HP 2006-09 60HP, 2009 25-30HP Evinrude



18-6744
TRIM MOTOR
Replaces: 5006319
Fits: 75-90 HP (04-Up), 115 HP (07-Up), 130 HP (10-Up)



18-6816
TRIM MOTOR
Replaces: 172588, 173944
Fits: 40, 50, 70, and 75HP with short shaft



18-6252
TILT & TRIM MOTOR REPAIR KIT
For use with 18-6767-1
*** Includes Brushes**



POWER TRIM ASSEMBLIES

PART NO.	OE NO.	APPLICATION
18-6801	5005114	115-130HP, V4 (2000-09)
18-6802	5005113	135-200HP, V6, 60° (2000-09)
18-6803	5005115/5007662	200-250HP, V6, 90° (2000-09)



**18-5705
POWER TRIM RELAY**
Replaces:
582472, 584416, 586224
5 Terminal • Single Pull
Double Throw • 12 Volt

Contact	Resistive	Conductive
Open	40 Amps	30 Amps
Closed	20 Amps	15 Amps

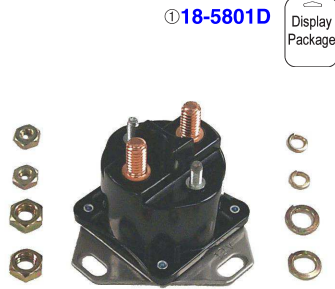

① 18-5801D

Display Package

**18-5801
SOLENOID**
Replaces: 985064, 586842,
586730
Grounded Base

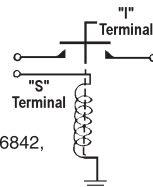

⑥ 18-5823D

Display Package

**18-5823
SOLENOID**

Replaces: 584580
Fits: 9.9 4-stroke(1995-01), 9.9 (1993 & Up),
15 4-stroke(1995-01), 15 (1993 & Up), 8
(1996-98).

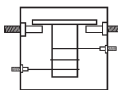

⑥ 18-5833D

Display Package

**18-5833
SOLENOID**

Replaces: 586774
Fits: E40 (2004-07), E50 (2004-06), E60
(2006-07), E75 (2004-07), E90 (2004-07),
E115 (2007), E150 (2007), E175 (2007), E200
(2005-07), E225 (2005-07), E250 (2005-07)

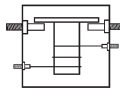

**18-5807
SOLENOID**

Replaces: 378444,
Prestolite SAW4206

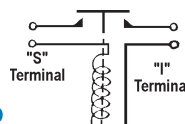

⑥ 18-5808D

Display Package

**18-5808
SOLENOID**

Replaces: 395419, 582708

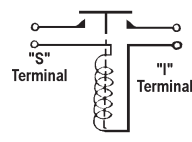

**18-5813
SOLENOID**

Replaces: 584128

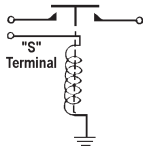

⑥ 18-5814D

Display Package

**18-5814
SOLENOID**

Replaces: 581528, 172869

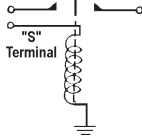

BATTERY CABLES

Gauge cable with soldered lug terminals on each end to accept 3/8" stud.

Part No.	Size	Color	Gauge	Part No.	Size	Color	Gauge
BC88523	2'	red	4	BC88563	6'	red	2
BC88533	2'	black	4	BC88573	6'	black	2
BC88543	4'	red	2	BC88583	8'	red	1
BC88553	4'	black	2	BC88593	8'	black	1

JOHNSON/EVINRUDE STARTER SOLENOID APPLICATION

HP	Year Start	Year Stop	Starter Solenoid	HP	Year Start	Year Stop	Starter Solenoid
9.9	1990	1992	18-5813	33	1968	1970	18-5808
15	1990	1992	18-5813	35	1957	1959	18-5807
18	1957	1959	18-5807	35	1976	1988	18-5808
20	1985	1998	18-5808	35	1991	2001	18-5808
25	1972	2005	18-5808	40	1960	1966	18-5807
25	2009	2009	18-5833	40	1967	1976	18-5808
28	1986	1996	18-5808	40	1984	2005	18-5808
30	1984	2005	18-5808	40	2004	2009	18-5833
30	2009	2009	18-5833	45	1989	1992	18-5808
33	1965	1967	18-5807	48	1987	1996	18-5808

① Without Electric Shift ② With Electric Shift

APPLICATION CONTINUED ON NEXT PAGE

JOHNSON/EVINRUDE STARTER SOLENOID APPLICATION (CONT.)

HP	Year Start	Year Stop	Starter Solenoid	HP	Year Start	Year Stop	Starter Solenoid
50	1958	1959	18-5807	100	1984	2001	18-5808
50	1971	1975	18-5808	105	1998	2003	18-5808
50	1979	2005	18-5808	110	1986	1989	18-5808
50	2004	2009	18-5833	112	1994	1996	18-5808
55	1968	1969	18-5808	115	1969	1970	18-5808
55	1976	1981	18-5808	115	1973	1985	18-5808
55	1989	1992	18-5808	115	1990	2006	18-5808
55	1996	1997	18-5808	115	2007	2009	18-5833
55	2008	2009	18-5833	120	1985	1994	18-5808
60	1964	1966	18-5807	125	1971	1972	18-5808
60	1967	1971	18-5808	125	1989	1990	18-5808
60	1980	2001	18-5808	125	1992	1998	18-5808
60	2006	2009	18-5833	130	1995	2000	18-5808
65	1968	1968	18-5808	130	2009	2009	18-5833
65	1972	1973	18-5808	135	1973	1976	18-5808
65	1984	2001	18-5808	135	2001	2001	18-5808
65	2008	2009	18-5833	140	1977	1994	18-5808
70	1970	2001	18-5808	150	1978	2006	18-5808
75	1960	1964	18-5807	150	2007	2009	18-5833
75	1965	1965	18-5807 ⓐ	155	1984	1992	18-5808
75	1965	1965	18-5808 ⓑ	175	1977	2006	18-5808
75	1975	1988	18-5808	175	2007	2009	18-5833
75	2004	2009	18-5833	185	1984	1985	18-5808
80	1966	1966	18-5807 ⓐ	185	1989	1994	18-5808
80	1966	1967	18-5808 ⓑ	200	1976	2001	18-5808
85	1968	1980	18-5808	200	2005	2009	18-5833
85	1991	1995	18-5808	225	1986	2001	18-5808
88	1987	1996	18-5808	225	2005	2009	18-5833
90	1964	1964	18-5807	235	1978	1985	18-5808
90	1965	1965	18-5808	250	1991	2001	18-5808
90	1981	2006	18-5808	250	2005	2009	18-5833
90	2004	2009	18-5833	275	1985	1988	18-5808
100	1966	1968	18-5808	300	1985	1995	18-5808
100	1971	1972	18-5808	300	2008	2009	18-5833
100	1979	1980	18-5808				

ⓐ Without Electric Shift ⓑ With Electric Shift

JOHNSON/EVINRUDE TRIM RELAY/SOLENOID APPLICATION

HP	Year Start	Year Stop	Trim Relay / Solenoid	HP	Year Start	Year Stop	Trim Relay / Solenoid
60	1986	2001	18-5705	125	1989	1998	18-5705
65	1991	1995	18-5705	135	1976	1976	18-5814
70	1980	1981	18-5814	140	1977	1981	18-5814
70	1981	2001	18-5705	140	1981	1994	18-5705
75	1980	1981	18-5814	150	1978	1981	18-5814
75	1982	1987	18-5705	150	1981	2006	18-5705
75	2000	2003	18-5705	175	1977	1981	18-5814
85	1976	1980	18-5814	175	1981	2006	18-5705
85	1991	1995	18-5705	185	1984	1985	18-5705
88	1986	1996	18-5705	185	1990	1994	18-5705
90	1981	1981	18-5814	200	1976	1981	18-5814
90	1981	2006	18-5705	200	1981	1983	18-5705
100	1979	1980	18-5814	200	1986	2005	18-5705
100	1984	2005	18-5705	225	1986	2005	18-5705
110	1986	1989	18-5705	235	1978	1981	18-5814
115	1976	1981	18-5814	235	1981	1985	18-5705
115	1981	1985	18-5705	250	1991	2005	18-5705
115	1990	2006	18-5705	275	1985	1988	18-5705
120	1985	1994	18-5705	300	1985	1995	18-5705

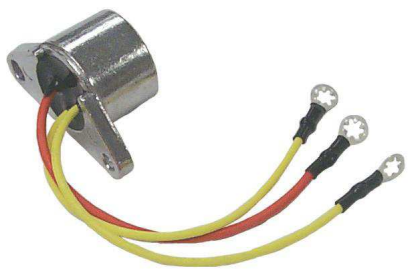

18-5708
RECTIFIER
Replaces: 582399, 583408
6-10 AMP

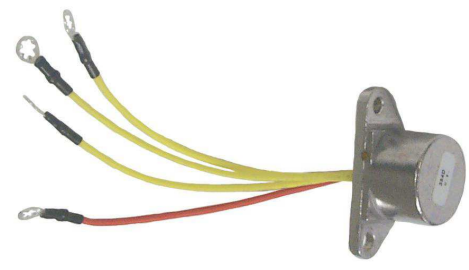

18-5709
RECTIFIER
Replaces: 581778
4-5 AMP



18-5825
REGULATOR/RECTIFIER
Replaces: 395204



18-5826
REGULATOR/RECTIFIER
Replaces: 584890



18-5827
REGULATOR/RECTIFIER
Replaces: 585001, 584476



18-5828
REGULATOR/RECTIFIER
Replaces: 585219, 439561



18-5829
REGULATOR/RECTIFIER
Replaces: 586048



18-5830
REGULATOR/RECTIFIER
Replaces: 586075



18-5831
REGULATOR/RECTIFIER
Replaces: 586271, 584641, 585995

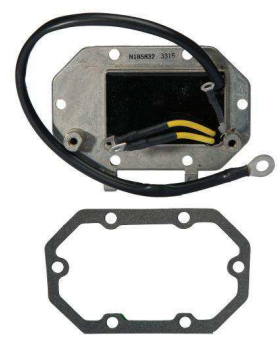

18-5832
REGULATOR/RECTIFIER
Replaces: 583266, 583689,
586000, 584424

REGULATOR/RECTIFIER APPLICATION ON NEXT PAGE

Model	Year	Part #	Model	Year	Part #
9.9,15	1974-92	18-5709	90	1981-92	18-5708
20	1989-98 ④	18-5709	90-115 60 DEGREE-V4	1996-UP	18-5830
25	1977-03 (2 CYL) ④	18-5709	100	1971,1979-80,1984-92 ③	18-5708
25/40/50TL/ J ELEC TR	1992	18-5827	115	1973-92	18-5708
25SIK/ SIL/ SIT	1994-1995	18-5827	120/140	1985	18-5832
25/35 3 CYL.	1995-UP	18-5826	125	1971-72	18-5708
28	1989-96	18-5709	135	1974 ⑦	18-5708
30	1989-03 (2 CYL) ④	18-5709	135	1973,1975-76	18-5708
35	1976-93 (2 CYL) ④	18-5709	140	1977-88	18-5708
35JET/ TL/ J ELEC.	1992-1993	18-5827	150	1979-88	18-5708
35JET/ M-TE/ TTL	1993-1995	18-5827	150/175 60 DEGREE-V6	1991-1995	18-5828
35JET/ EL/ TL/ TTL	1996	18-5827	150/175 60 DEGREE-V6	1996-UP	18-5829
35JET ELEC.	1997	18-5827	155	1984-88	18-5708
40	1974-76,1988-92	18-5709	175	1977-83	18-5708
40/50TE/ EL/ TL/ TTL	1993-1996	18-5827	185	1984-88	18-5708
40/ 50 ELEC. 2 CYCLE.	1993-03 (2 CYCLE.)	18-5827	185/200/225	1993-1994	18-5831
45	1989-92 COMM	18-5709	185/200/225/200COMM	1990-1992	18-5832
45SS	1989-90	18-5709	200	1976-83	18-5708
48	1989-92	18-5709	200/225	1986-1989	18-5832
50	1971-75	18-5708	200/225/200COMM	1994-1997	18-5831
50	1979-92	18-5709	235	1978-88	18-5708
55	1976-77	18-5708	250/300	1991-1995	18-5831
55	1978-81, 1980-92 ①	18-5709	250	1997	18-5831
60	1970 ⑤, 1971	18-5708	275	1985-1986	18-5832
60	1980-88	18-5709	275/300 (3.6L)	1987	18-5832
60	1989-91 ⑥	18-5708	275/300	1988	18-5832
SST60	1989-90	18-5708	300 (3.6L) — PORT & STBD.	1985-1986	18-5832
60	1992-01	18-5827	300	1989-1990	18-5832
65	1972-73, 1988-91	18-5708	1.8/2.0L V4 "S"	1987-1990	18-5832
65 ELEC.	1992	18-5827	2.7L V6	1986-1987	18-5832
70	1974-91 ②	18-5827	3.0L V6	1988-1990	18-5832
70	1992-01	18-5708	3.0L V6	1993-1998	18-5832
75	1975-88	18-5708	3.6L V8	1987	18-5832
85	1970-80	18-5708	4.0L V8	1989-1990	18-5832
88	1989-92	18-5708	V-4 & V-6 Crossflow with 35 AMP	ALL	18-5825

- ① Also Commercial Models
- ② 1991 EL & TL Models only
- ③ Except 1992 Models WTLNE & WTXENE

- ④ Electric Start only
- ⑤ D Models only

- ⑥ EL & TL Models only
- ⑦ 135443, 135483 Models only



18-6434
OUTBOARD STARTER

Replaces: 386430, 763454
Fits: 9.9, 15 HP (1974-92), 8 HP 4 Stroke (1996-98)



18-5640
OUTBOARD STARTER

Replaces: 395207, 387094, 585062, 586288, 778992
Fits: 150-235 HP, V6 models

ALL STARTERS ARE COUNTER CLOCKWISE ROTATION
STARTER APPLICATION ON PAGE 266



18-5612
OUTBOARD STARTER
Replaces: 432925, 586287, 586286
Fits: 175 HP models (1992)



18-5617
OUTBOARD STARTER
Replaces: 586274, 778995
Fits: 9.9, 15 HP models



18-5619
OUTBOARD STARTER
Replaces: 584799, 396235, 391511, 397023, 586731, 586890
Fits: V6/V8 Looper models



18-5624
OUTBOARD STARTER
Replaces: 583482, 585056, 586279
Fits: 20-35 HP models (1989 & up)



18-5627
OUTBOARD STARTER
Replaces: 583473, 585059, 585459, 778991
Fits: 20-35 HP models (1987-93)



18-5628
OUTBOARD STARTER
Replaces: 393570, 585060, 586285, 778994
Fits: 140 HP models (1993)



18-5629
OUTBOARD STARTER
Replaces: 392133, 585061, 386591, 586278
Fits: 18-40 HP models



18-5630
OUTBOARD STARTER
Replaces: 387684, 585063, 389275, 384163, 586280, 778993
Fits: 50-60 HP, 2 cyl. models



18-5631
OUTBOARD STARTER
Replaces: 584818, 586277, 778996
Fits: V-4, 60° models (1997 & up)



18-5632
OUTBOARD STARTER
Replaces: 584980, 586284
Fits: V-4, 60° models (1997 & up)



18-5634
OUTBOARD STARTER
Replaces: 585057, 585051, 385529, 389954, 586283
Fits: 140 HP models (1977)



18-5648
OUTBOARD STARTER
Replaces: 585058, 586281, 386657, 391735, 585050, 384777
Fits: 70 HP models

ALL STARTERS ARE COUNTER CLOCKWISE ROTATION
 STARTER APPLICATION ON NEXT PAGE



18-6826
STARTER
Replaces: 586768, 587045
Fits: 40-90HP E-Tec Engines



18-6863
STARTER
Replaces: 584608, 586275
Fits: Johnson/Evinrude 9.9-15HP 4-Stroke Engines



18-6945
STARTER
Replaces: 5036972
Fits: Johnson, Suzuki 25HP 2006-11



18-6250
OUTBOARD STARTER REPAIR KIT
Prestolite
2 Brush



18-6251
OUTBOARD STARTER REPAIR KIT
Prestolite
4 Brush



18-5655
DRIVE ASSEMBLY
Replaces: 321648
See next page for additional application

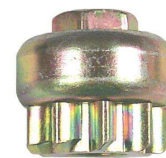

18-5671
DRIVE ASSEMBLY
Replaces: 384781
See next page for additional application

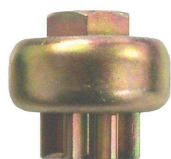

18-5674
DRIVE ASSEMBLY
Replaces: 387683
See chart below for additional application

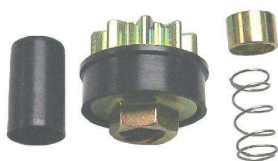

18-5678
DRIVE ASSEMBLY
Replaces: 585269, 586101
See chart below for additional application



18-5679
DRIVE ASSEMBLY
Replaces: 585267, 586100
See chart below for additional application



18-5697
DRIVE BRUSH KIT
Replaces: 385952
See chart below for additional application

HP	Years	Starter #	O.E. Part #	O.E. #	Drive Assembly ②	O.E. #	Tooth Count	Drive Brush Kit ②	O.E. #
9.9/ 15	1974-92	—	386430	395264	—	319977	10	NA	NA
9.9/ 15	1993 & UP	18-5617	586274	395264	—	319977	10	NA	NA
9.9/ 15	1997 & Up 4 stroke	—	584613	NSS	18-5679 ①	585267	10	18-5697	385952
20 ⑦	1985-88	18-5629	586278	393354	18-5655	321648	11	18-5697	385952
20 thru 30 ⑦	1993-98	18-5629	586278	393354	18-5655	321648	11	18-5697	385952
25 thru 35 ⑦	1977-88	18-5629	586278	NSS	18-5655	321648	11	18-5697	385952
20 thru 30 ⑤	1989-92	18-5627	585059	393354	18-5671 ①	384781	9	18-5697	385952
25 thru 35	1997-99 3 cylinders	18-5631	586277	586100	NSS ①	NSS	10	18-5697	385952
40-50	1984-88	18-5630	586280	NSS	18-5671 ①	384781	9	18-5697	385952
50	1972	18-5630	586280	NSS	18-5671 ①	585269	9	18-5697	385952
40-50 ①	1989-99	18-5624	586279	NSS	18-5678 ①	585269	9	18-5697	385952
55	1978	18-5630	586280	NSS	18-5678 ①	585269	9	18-5697	385952
60	1985 2 cylinders	18-5630	586280	NSS	18-5678 ①	585269	9	18-5697	385952
50	1985-99 3 cylinders	18-5648	586281	NSS	18-5678 ①	585269	9	18-5697	385952
55	1969	18-5648	586281	NSS	18-5678 ①	585269	9	18-5697	385952
60	1971	18-5648	586281	NSS	18-5671*	384781	9	18-5697	385952
60	1986-01 3 cylinders	18-5648	586281	NSS	18-5678 ①	585269	9	18-5697	385952
65	1985-01 3 cylinders	18-5648	586281	NSS	18-5678 ①	585269	9	18-5697	385952
70, 75	1980-01	18-5648	586281	NSS	18-5678 ①	585269	9	18-5697	385952
85 thru 115	1973-99 crossflows	18-5634	586283	NSS	18-5679 ①	586100	10	18-5697	385952

ALL STARTERS ARE COUNTER CLOCKWISE ROTATION
STARTER APPLICATION CONTINUED ON NEXT PAGE

HP	Years	Starter #	O.E. Part #	O.E. #	Drive Assembly ②	O.E. #	Tooth Count	Drive Brush Kit ②	O.E. #
90, 115	1995-99 looper	18-5632	586284	NA	NA	NA	NA	18-5697	385952
120 thru 140	1985-94	18-5628	586285	NSS	18-5679 ①	586100	10	18-5697	385952
130	1995-99	18-5628	586285	NSS	18-5679 ①	586100	10	18-5697	385952
V-6 Crossflow	1976-92	18-5640	586288	393285	18-5674	387683	8	18-5697	385952
150, 175 60°	1991-99 loopers	18-5612	586286	NA	NA	NA	NA	18-5697	385952
150 thru 175 V-6	1997-03	18-5612	586287	NSS	NSS	NA	NA	NA	433850
200 thru 300	1986-Up std. rotation	18-5619	586411	397375	NA	NA	10	18-5697	385952

Note: Some starters will replace Prestolite versions however replacement parts are for Bosch versions only.
 * Starter drive retained with nut

NSS Not sold separately

① Drive kit includes drive assembly with clip style retainer

② Drive kits, drive assemblies, and brush sets offered are for "Bosch Style" starters only.

⑤ With 9 tooth pinion

⑦ For Bosch models

4-STROKE FUEL SYSTEM KITS



18-7761
CARBURETOR REBUILD KIT
 Fits: Johnson/Evinrude Four-Stroke 4-6 hp. (2007)



18-7773
CARBURETOR REBUILD KIT
 Replaces: 5032424
 Fits: 25, 30 HP (2000-01) (2004 & Up)

2-STROKE FUEL SYSTEM KITS



18-7010
CARB KIT
 Replaces: 382050, 382051, 382054



18-7024
CARB KIT
 Replaces: 382053, 382052, 385356, 439075



18-7026
CARB KIT
 Replaces: 382057



18-7042
CARB KIT
 (without float)
 Replaces: 392061, 398729, 396701



18-7222
CARB KIT
 (with float)
 Replaces: 392061, 398729, 396701



18-7043
CARB KIT
 Replaces: 382045, 382046, 382047, 382049, 383052, 383067, 398532, 439071, 398514



18-7046
CARB KIT
 Replaces: 390055, 392550, 398526, 435443, 434888, 439076, 433519
 Contains [18-7038](#) Needle/Seat



18-7219
CARB KIT
 Replaces: 439073, 431897



18-7221
CARB KIT
 Replaces: 435442, 438996

2-STROKE FUEL SYSTEM KITS



18-7223
CARB KIT w/ Needle & Seat
Replaces: 398452, 391305, 398453, 439072, 391937



18-7247
CARB KIT
Replaces: 438996, 436852
For: V4 & V6 (60°) 1988-2001



18-7248
CARB KIT
Replaces: 437327, 439079, 439078, 435676, 435677, 435678, 435752



18-0871
SERVICE VALVE WITH O-RING
Replaces: 175158
Fits: All Johnson/Evinrude with primer valve (except 1993 9.9 & 15hp.)



18-7044
SERVICE VALVE KIT
Replaces: 175158+437228
Fits: All Johnson/Evinrude with primer valve (except 1993 9.9 & 15 H.P.)



18-0993
COVER & GASKET ASSEMBLY
Replaces: 437228
Fits: All Johnson/Evinrude with primer valve (except 1993 9.9 & 15hp.)



NEEDLE & SEAT

Part #	Replaces
18-7093	396521, 678882, 378895
18-7094	379313, 396522
18-7038	396520, 379312, 387262

PKG. OF 10



18-7106
18-7106-9^①
NEEDLE PACKING
Replaces: 307583



18-7210
FLOAT
Replaces: 382363

PKG. OF 5



18-7296
18-7296-9^①
ADJUSTING NEEDLE RETAINER
Replaces: 315232

① Priced per Package

HP	YEAR	CARB. KIT W/O FLOAT	CARB. KIT W/ FLOAT	NEEDLE & SEAT	CARB. FLOAT
1.5	1970-90	18-7043	—	18-7094	—
2	1970-90	18-7043	—	18-7094	—
3	1952-67	18-7043	—	18-7038	—
3	1968	18-7043	—	18-7094	—
4	1983-89	18-7223	—	18-7094	—
4	1991-93	18-7223	—	18-7094	—
4.5	1982-84,1987	18-7223	—	18-7094	—
5	1965-67	18-7043	—	18-7094	—
5	1968	18-7024	—	18-7093	—
5	1984-85	18-7223	—	18-7094	—
5.5	1954-67	18-7043	—	18-7094	—
6	1954-79	18-7043	—	18-7094	—
6	1968	18-7024	—	18-7093	—
6	1984-85	18-7223	—	18-7094	—
6, 8	1986-96	18-7219	—	—	—
7.5	1955-58	18-7043	—	18-7094	—
7.5	1982-83	18-7223	—	18-7094	—
8	1984-85	18-7223	—	18-7094	—
9.9	1974-88	18-7223	—	18-7094	—

① Commercial ② Also Commercial ③ Early Production ④ Cross Flow ⑤ Except 1995-Up 3 Cylinder Models

HP	YEAR	CARB. KIT W/O FLOAT	CARB. KIT W/ FLOAT	NEEDLE & SEAT	CARB. FLOAT
9.9/15	1989-96	18-7219	—	—	—
10	1954-63	18-7043	—	18-7094	—
14	1968 ③	18-7223	—	18-7094	—
15	1955-56	18-7043	—	18-7094	—
15	1974-88	18-7223	—	18-7094	—
18	1957-68	18-7043	—	18-7094	—
18	1969-73	18-7042	18-7222	18-7093	18-7210
20	1957-68	18-7043	—	18-7094	—
20	1969-90	18-7042	18-7222	18-7093	18-7210
20	1991-96	18-7219	—	18-7094	—
25	1954-55	18-7024	—	18-7093	—
SAIL DR	1978-UP	18-7042	18-7222	18-7093	18-7210
25	1969-95 ⑤	18-7042	18-7222	18-7093	18-7210
28	1962-64	18-7010	—	18-7093	—
28	1976-95	18-7042	18-7222	18-7093	18-7210
30	1956	18-7024	—	18-7093	—
30	1976-UP	18-7042	18-7222	18-7093	18-7210
33	1965-70	18-7010	—	18-7093	—
35	1957-59	18-7024	—	18-7093	—
35	1959	18-7010	—	18-7093	—
35	1976-95 ⑤	18-7042	18-7222	18-7093	18-7210
40	1960-63, 1971	18-7010	—	18-7093	—
40	1965-70, 1972-78	18-7024	—	18-7093	—
40	1971-90, 1979-92 ①	18-7042	18-7222	18-7093	18-7210
45	1971-97 ②	18-7042	18-7222	18-7093	18-7210
48	1992-97	18-7042	18-7222	18-7093	18-7210
50	1958-59	18-7026	—	18-7093	—
50	1971-97	18-7042	18-7222	18-7093	18-7210
55	1968-69, 1971-97 ②	18-7042	18-7222	18-7093	18-7210
60	1964-67	18-7026	—	18-7093	—
60	1970-97	18-7042	18-7222	18-7093	18-7210
65	1972-97	18-7042	18-7222	18-7093	18-7210
70	1972-97 (3 CYL)	18-7042	18-7222	18-7093	18-7210
75	1960-63	18-7026	—	18-7093	—
75	1975-88	18-7042	18-7222	18-7093	18-7210
80	1966-67	18-7026	—	18-7093	—
85	1968	18-7026	—	18-7093	—
85	1971-79	18-7046	—	18-7093	—
85	1969-70, 1991-93	18-7046	—	18-7038	—
V-4	1969-79	18-7046	—	18-7038	—
V-4	1983-84	18-7046	—	18-7038	—
88,90	1985-95	18-7046	—	18-7038	—
90	1981-82, 1983 ③	18-7046	—	18-7038	—
90	1995-02	18-7247	—	—	—
100	1971, 1980	18-7046	—	18-7038	—
100	1972, 1979	18-7046	—	18-7093	—
100	1998-01	18-7247	—	—	—
105	1999-01	18-7247	—	—	—
115	1969, 1980-95	18-7046	—	18-7038	—
115	1995-02	18-7046	—	18-7093	—
115	1995-02	18-7247	—	—	—
V-6	1976-90 ④	18-7046	—	18-7038	—
115	1983	18-7046	—	18-7038	—
120	1985-90	18-7248	—	18-7094	—
120	1985-90, 1993	18-7248	—	18-7094	—

① Commercial ② Also Commercial ③ Early Production ④ Cross Flow ⑤ Except 1995-Up 3 Cylinder Models

HP	YEAR	CARB. KIT W/O FLOAT	CARB. KIT W/ FLOAT	NEEDLE & SEAT	CARB. FLOAT
125	1971-72	18-7046	—	18-7093	—
125	1993	18-7248	—	18-7094	—
125C	1989-95	18-7248	—	18-7094	—
135	1973-76	18-7046	—	18-7093	—
140	1977, 1980-83	18-7046	—	18-7038	—
140	1978-79	18-7046	—	18-7093	—
140	1985-90	18-7248	—	18-7094	—
140	1993	18-7248	—	18-7094	—
150	1979-90	18-7046	—	18-7038	—
150	1992-96, 1998-02	18-7247	—	—	—
155	1984-93 ①	18-7046	—	18-7038	—
175	1977-91	18-7046	—	18-7038	—
175	1992-96, 1998-02	18-7247	—	—	—
185	1984	18-7046	—	18-7038	—
185	1989-93	18-7221	—	18-7094	—
200	1976-83	18-7046	—	18-7038	—
200	1986-90	18-7248	—	18-7094	—
200	1992-93	18-7221	—	18-7094	—
225	1986-90, 1992-93	18-7221	—	18-7094	—
235	1978-84	18-7046	—	18-7038	—
250	1991-93	18-7221	—	18-7094	—
275/3.6L	1985-88	18-7221	—	18-7094	—
300	1988, 1991-93	18-7221	—	18-7094	—

① Commercial ② Also Commercial ③ Early Production ④ Cross Flow ⑤ Except 1995-Up 3 Cylinder Models



18-7350
FUEL PUMP
Replaces: 397839, 391638, 395091, 397274
For: 6/8/9.9/15 HP 1981-92
Uses kit **18-7823**



18-7351
FUEL PUMP
Replaces: 434728, 438562
For: 9.9/15 HP 1993-2006
Uses kit **18-7800**



18-7352
FUEL PUMP
Replaces: 438556, 388268, 385781, 394543, 382354, 395713, 398338, 432451, 398387, 433387
For: 25-55 HP 1976-89 (non-VRO)
Uses kit **18-7821**



18-7353
FUEL PUMP
Replaces: 438555, 433386
For: 20-30 HP 1990-2000
Uses kit **18-7800**



18-7800
FUEL PUMP KIT
Replaces: 438616, 433519



18-7801
FUEL PUMP KIT
Replaces: 379777



18-7820
FUEL PUMP KIT
Replaces: 393103



18-7821
FUEL PUMP KIT
Replaces: 398514, 395867



18-7822
FUEL PUMP KIT
Replaces: 432962

 <p>18-7823 FUEL PUMP KIT Replaces: 393088</p>	<p>PKG. OF 2</p>  <p>18-7796 18-7796-9④ CHECK VALVE Replaces: 335334 (Enlarged to show detail)</p>	 <p>18-3497 DIAPHRAGM KIT Replaces: 5033372 4-5 HP (2003-06), 6 HP (2005-06) 4-Stroke</p>
--	---	---

 <p>18-3498 DIAPHRAGM KIT Replaces: 5036216, 5037584 10-15 HP (2005-07) 4-Stroke</p>	 <p>18-3499 DIAPHRAGM KIT Replaces: 5030699 9.9, 15 HP (2002-04), 25HP (2004-06), 30HP (2004-07), 40-70 HP (2002-06) 4-Stroke</p>
--	---

FUEL PUMP REPAIR KIT APPLICATION

ALL KITS ARE FOR NON-VRO (VARIABLE RATIO OILING) PUMPS

HP	Year Start	Year Stop	Fuel Pump Repair Kit	HP	Year Start	Year Stop	Fuel Pump Repair Kit	HP	Year Start	Year Stop	Fuel Pump Repair Kit
2.5	1987	1988	18-7823	25	2001	2001	18-3497④	50	1990	2012	18-7800
3	1989	1997	18-7823	25	2004	2005	18-3497④	50	AA	AG	18-7800
4	1982	2001	18-7823	28	1962	1963	18-7801	50	1999	2006	18-3497④
4	2003	2007	18-3497④	28	1986	1987	18-7821	55	1983	1984	18-7820
4.5	1982	1987	18-7823	28	1988	1990	18-7822	55	1985	1990	18-7821
5	1982	1983	18-7823	28	1990	1998	18-7800	55	1991	2005	18-7800
5	1985	1993	18-7823	30	1984	1984	18-7820	55	2008	2012	18-7800
5	1996	1998	18-7823	30	1985	1987	18-7821	55	AA	AG	18-7800
5	2003	2007	18-3497④	30	1988	1990	18-7822①	60	1964	1967	18-7801
6	1984	2005	18-7823	30	1990	2005	18-7800②	60	1982	1984	18-7820
6	1987	1987	18-7821	30	2001	2001	18-3497④	60	1985	1985	18-7821
6	2003	2007	18-3497④	30	2004	2007	18-3497④	60	1988	1988	18-7821
7.5	1980	1983	18-7823	35	1958	1959	18-7801	60	2002	2006	18-3497④
8	1982	2005	18-7823	35	1976	1984	18-7820	60	2005	2012	18-7800
8	1987	1987	18-7821	35	1986	1987	18-7821	60	AA	AG	18-7800
9.9	1974	1992	18-7823	35	1988	1990	18-7822	65	1984	1984	18-7820
9.9	1987	1990	18-7821②	35	1990	2001	18-7800	65	1985	1985	18-7800④
9.9	1990	1999	18-7800	40	1960	1964	18-7801	65	1985	1986	18-7821
10	1996	2007	18-7800	40	1971	1976	18-7820	65	1989	1989	18-7821
10	2002	2004	18-3497④	40	1983	1984	18-7820	65	1991	2001	18-7800
10	2005	2007	18-3497④	40	1985	1987	18-7821	65	2008	2012	18-7800
14	1988	1989	18-7823	40	1988	1990	18-7822①	65	AA	AF	18-7800
15	1974	1998	18-7823	40	1990	2012	18-7800②	70	1982	1984	18-7820
15	1987	1990	18-7821②	40	AA	AG	18-7800	70	1998	2006	18-3497④
15	1990	2007	18-7800	40	1999	2006	18-3497④	75	1960	1965	18-7801
15	2002	2004	18-3497④	45	1958	1959	18-7801	75	1982	1984	18-7820
15	2005	2007	18-3497④	45	1986	1990	18-7821	75	2004	2012	18-7800
20	1985	1987	18-7821	45	1991	1997	18-7800	75	AA	AF	18-7800
20	1988	1990	18-7822①	48	1987	1987	18-7821	80	1966	1967	18-7801
20	1990	1998	18-7800②	48	1988	1990	18-7822①	85	1977	1983	18-7820
25	1971	1976	18-7823	48	1990	1996	18-7800②	88	1987	1990	18-7821①
25	1977	1984	18-7820	50	1958	1959	18-7801	88	1990	1996	18-7800②
25	1985	1987	18-7821	50	1982	1984	18-7820	90	1964	1965	18-7801
25	1988	1990	18-7822①	50	1985	1987	18-7821	90	1981	1983	18-7820
25	1990	2005	18-7800②	50	1988	1990	18-7822	90	1997	1998	18-7800

④ Priced per Package

APPLICATION CONTINUED ON NEXT PAGE

FUEL PUMP REPAIR KIT APPLICATION

ALL KITS ARE FOR NON-VRO (VARIABLE RATIO OILING) PUMPS

HP	Year Start	Year Stop	Fuel Pump Repair Kit	HP	Year Start	Year Stop	Fuel Pump Repair Kit	HP	Year Start	Year Stop	Fuel Pump Repair Kit
90	2004	2012	18-7800	112	1994	1996	18-7800	150	1978	1984	18-7820
90	AA	AF	18-7800	115	1982	1983	18-7820	175	1977	1983	18-7820
100	1966	1966	18-7801	115	1997	1998	18-7800	200	1977	1983	18-7820
100	1989	1990	18-7821	115	2004	2005	18-7800	235	1978	1984	18-7820
100	1996	1997	18-7800	125	1995	1998	18-7800				
105	1997	2003	18-7800	140	1977	1983	18-7820				

④ Priced per Package

APPLICATION CONTINUED ON NEXT PAGE

FUEL PUMP APPLICATION

HP	Year Start	Year Stop	Fuel Pump	HP	Year Start	Year Stop	Fuel Pump
6	1988	1991	18-7350	35	1990	1994	18-7353
8	1988	1991	18-7350	35	1996	1996	18-7353
9.9	1981	1992	18-7350	40	1968	1976	18-7352
9.9	1993	1999	18-7351	40	1983	1984	18-7352
10	1997	1998	18-7351	50	1974	1975	18-7352
10	2000	2001	18-7351	50	1979	1984	18-7352
10	2003	2007	18-7351	55	1976	1981	18-7352
15	1981	1998	18-7350	55	1983	1984	18-7352
15	1993	2007	18-7351	60	1980	1984	18-7352
20	1990	1998	18-7353	85	1977	1980	18-7352
25	1977	1984	18-7352	90	1981	1983	18-7352
25	1990	2005	18-7353	90	1997	1998	18-7352
28	1990	1996	18-7353	100	1979	1980	18-7352
30	1984	1984	18-7352	100	1997	1997	18-7352
30	1990	2005	18-7353	115	1977	1983	18-7352
33	1968	1970	18-7352	115	1997	1998	18-7352
35	1976	1984	18-7352	140	1977	1983	18-7352

FUEL WATER SEPARATOR KITS



21 MICRON FILTER KITS FOR CARBURETED ENGINES



KIT TYPE	PART #	MICRON RATING	CONTENTS
1/4" ALUMINUM (SHORT FILTER)	18-7848-1 •	21	1 - 18-7844 filter & 1 18-7853-1 bracket 2 - 18-4256 1/4" PIPE PLUGS
1/4" ALUMINUM BONUS PACK CONTAINS SPARE FILTER	18-7848-2 •	21	2 - 18-7844 FILTER & 1 18-7853-1 BRACKET 2 - 18-4256 1/4" PIPE PLUGS
1/4" ALUMINUM (TALL FILTER) CONTAINS SPARE FILTER	18-7852-1 •	21	1 - 18-7845 FILTER & 1 18-7853-1 BRACKET 2 - 18-4256 1/4" PIPE PLUGS
3/8" ALUMINUM (TALL FILTER)	18-7775-1 •	21	1 - 18-7845 FILTER & 1 18-7775 BRACKET 2 - 18-4264 3/8" PIPE PLUGS
1/4" STAINLESS STEEL (TALL FILTER)	18-7777-1 •	21	1 - 18-7845 FILTER & 1 18-7777 BRACKET 2 - 18-4256 1/4" PIPE PLUGS
3/8" STAINLESS STEEL (TALL FILTER)	18-7776-1 •	21	1 - 18-7845 FILTER & 1 18-7776 BRACKET 2 - 18-4264 3/8" PIPE PLUGS

• Display Packaged

**- UNIVERSAL DESIGN -
DIRECT REPLACEMENT FOR MERCURY AND YAMAHA
FUEL WATER SEPARATOR BRACKETS**



Bracket Type	Part #
1/4" Stainless Steel	18-7777
3/8" Stainless Steel	18-7776



Bracket Type	Part #
1/4" Aluminum	18-7853-1
3/8" Aluminum	18-7775

**10 MICRON FILTER KITS
FOR FUEL INJECTED ENGINES**

• Display Packaged

Kit Type	Part #	Micron Rating	Contents
1/4" Aluminum (Short Filter)	18-7983-1 •	10	1 - 18-7944 filter & 1 18-7853-1 bracket 2 - 18-4256 1/4" pipe plugs
1/4" Aluminum Bonus Pack Contains spare filter	18-7983-2 •	10	2 - 18-7944 filter & 1 18-7853-1 bracket 2 - 18-4256 1/4" pipe plugs
1/4" Aluminum (Tall Filter)	18-7982-1 •	10	1 - 18-7945 filter & 1 18-7853-1 bracket 2 - 18-4256 1/4" pipe plugs
1/4" Aluminum Bonus Pack Contains spare filter	18-7982-2 •	10	2 - 18-7945 filter & 1 18-7853-1 bracket 2 - 18-4256 1/4" pipe plugs
1/4" Aluminum (High Capacity Filter)	18-7966-1 •	10	1 - 18-7866 filter & 1 18-7853-1 bracket 2 - 18-4256 1/4" pipe plugs
3/8" Aluminum (Tall Filter)	18-7986-1 •	10	1 - 18-7945 filter & 1 18-7775 bracket 2 - 18-4264 3/8" pipe plugs
1/4" Stainless Steel (Tall Filter)	18-7984-1 •	10	1 - 18-7945 filter & 1 18-7777 bracket 2 - 18-4256 1/4" pipe plugs
3/8" Stainless Steel (Tall Filter)	18-7985-1 •	10	1 - 18-7945 filter & 1 18-7776 bracket 2 - 18-4264 3/8" pipe plugs



10 MICRON FILTER KITS WITH DRAIN BOWLS

Sierra AquaVue™ and metal bowl separator filters allow water to be drained from the filter to extend service life. Use the AquaVue™ bowl for outboard, above deck installations. USCG regulations require the use of the flame resistant metal bowl below deck.

Kit Type	Part #	Micron Rating	Contents
1/4" Aluminum w/ AquaVue™ bowl	18-7932-1 •	10	1 - 18-7919 filter & 1 18-7853-1 bracket 1 - 18-7922-1 AquaVue™ bowl 2 - 18-4256 1/4" pipe plugs
1/4" Aluminum w/ metal drain bowl	18-7951 •	10	1 - 18-7919 filter & 1 18-7853-1 bracket 1 - 18-7924 metal bowl 2 - 18-4256 1/4" pipe plugs
1/4" Stainless Steel w/ AquaVue™ bowl	18-7937-1 •	10	1 - 18-7919 filter & 1 18-7777 bracket 1 - 18-7922-1 AquaVue™ bowl 2 - 18-4256 1/4" pipe plugs
1/4" Stainless Steel w/ metal drain bowl	18-7938 •	10	1 - 18-7919 filter & 1 18-7777 bracket 1 - 18-7924 metal bowl 2 - 18-4256 1/4" pipe plugs

COMPACT BRACKET AND SEPARATOR KIT - FOR SMALL OUTBOARDS AND FRESH WATER APPLICATIONS

**18-7774
COMPACT ALUMINUM BRACKET**



**18-7965-1
10 MICRON COMPACT
SEPARATOR KIT**

Contains:
1 - 18-7774 bracket
1 - 18-7865 filter



• Display Packaged

REPLACEMENT FILTERS



UNIVERSAL DESIGN

10 MICRON REPLACEMENT FILTERS		21 MICRON REPLACEMENT FILTERS	
Part No.	Description	Part No.	Description
18-7944	Short - 3.875"	18-7844	Short - 3.875"
18-7945	Long - 4.35"	18-7845	Long - 4.35"
18-7866	High Capacity - 6"		
18-7865	Compact 10 Micron		

REPLACEMENT FILTERS FOR OMC

10 MICRON REPLACEMENT FILTERS			21 MICRON REPLACEMENT FILTERS		
Part No.	Description	Replaces	Part No.	Description	Replaces
18-7946	OMC thread	OMC 502905	18-7846	OMC thread	OMC 502905
18-7989	Cobra EFI	OMC 502906	18-7789	Cobra EFI	OMC 502906



• Display Packaged

10 MICRON REPLACEMENT FILTERS AND KITS WITH DRAIN BOWLS

REPLACEMENT ELEMENTS			ELEMENT & BOWL KITS		
Part No.	Description	Replaces	Part No.	Description	
18-7919	Spin on replacement	Racor S3213	18-7928-1 •	Filter & AquaVue™ Bowl Contains: 18-7919 filter, 18-7922-1 bowl	
18-7920	Spin on replacement OMC style	OMC 502906 Racor S3214	18-7929 •	Filter & Metal Bowl Contains: 18-7919 filter, 18-7924 bowl	
REPLACEMENT BOWLS			18-7941-1 •	Filter & AquaVue™ Bowl Contains: 18-7920 filter, 18-7922-1 bowl	
Part No.	Description		18-7943 •	Filter & Metal Bowl Contains: 18-7920 filter, 18-7924 bowl	
18-7922-1	AquaVue™ Collection Bowl				
18-7924	Metal Collection Bowl				

18-79781
FUEL FILTER
Replaces: 433190
60° V4 and V6



18-7953
FUEL FILTER
Replaces: 5035974
Fits: 25HP (2006-07) / 90,115,140
4 stroke (2005-06)



18-7716
FUEL FILTER
Replaces: 5032323
Fits: Johnson 25 4-Stroke (2004-05), 30
4-Stroke (2004-07), 40/60/70 4-Stroke
(2002-06), 90/115/140 4-Stroke (2003-04,
2006), Evinrude 25/30/40/50/70 4-Stroke
(2000-01)



18-7719
FUEL FILTER
Replaces: 5032238
Fits: Johnson 4/5 (2003-07), 6 4-Stroke
(2005-07), 10/15 4-Stroke (2002-07),
40/50/60/70 4-Stroke (2002-06), Evin-
rude 40/50 4-Stroke (2000-01)



18-7722
FUEL FILTER
• 3/8" barbs
Replaces: 5005266
For: E-Tec 40, 50, 60, 75, 90,115, 150, 175 & 200DPL



18-7826
FUEL FILTER
Replaces: 305185



INLINE FUEL FILTERS

Part No.	Application
18-7828-1•	1/4" Small Capacity (For 1/4" Fuel Line)
18-7829	1/4" Large Capacity (For 1/4" Fuel Line)
18-7830	5/16" Replaces: OMC 398327
18-7831	3/8" Replaces: OMC 398319



8' LENGTH COMPLETE FUEL LINE ASSEMBLIES

3/8" FUEL LINE ASSEMBLY **18-8009EP-2 SILVERADO 4000 Premium** **OE# 398549**



18-8063 TANK CONNECTOR
(SOLD SEPARATELY)



18-8092 FUEL CONNECTOR



18-8005EP-1 PRIMER BULB



18-8092 FUEL CONNECTOR



FUEL LINE ASSEMBLY COMPONENTS
Fits: 2 HP (1 cyl.) - 75 HP (3 cyl.) (1976-02)

8' LENGTH COMPLETE FUEL LINE ASSEMBLIES

3/8" FUEL LINE ASSEMBLY **18-8014EP-2 SILVERADO 4000 Premium** **OE# 174509**



18-8074 HOSE BARB
(SOLD SEPARATELY)



18-8074 HOSE BARB
(SOLD SEPARATELY)



18-8005EP-1 PRIMER BULB



18-8092 FUEL CONNECTOR



FUEL LINE ASSEMBLY COMPONENTS
Fits: All V6 & V8 (1976-02)



18-8004EP-1
18-8004-10EP-1
PRIMER BULB
5/16"
Replaces: 174511, 775638
Large capacity bulb



18-8005EP-1
18-8005-10EP-1
PRIMER BULB
3/8"
Replaces: 174512
Large capacity bulb

HOSE BARB APPLICATION

INLINE FUEL FILTERS				
Part No.	OMC No.	Barb	NPT	Conn. Type
18-8055	173311	5/16"	1/4"	Male
18-8074	173312	3/8"	1/4"	Male



18-8056
18-8056-10
FUEL CONNECTOR
5/16"
Replaces: 174508, 775640
Mates with **18-8063**



18-8063
18-8063-10
TANK CONNECTOR
Replaces: 502867, 772681, 0772681
(1/4" NPT)
Mates with **18-8056** & **18-8092**



18-8072 FUEL ELBOW
3/8" Barb w/ 3/8" NPT Thread
Replaces: 174177
90°



18-8092 FUEL CONNECTOR
3/8"
Replaces: 176445, 775641
Mates with **18-8063**



18-3290 INDICATOR ELBOW
Replaces: 321886
Pipe threaded to hose



BLEEDER HOSE

18-8048 **18-8050**
.090 I.D. x .220 O.D. .0625 I.D. x .190 O.D.



18-8051 FUEL LINE HOSE
1/8" I.D.
Replaces: 322656
For OMC Pressurized Systems



18-8052 FUEL LINE HOSE
3/16" I.D.
Replaces: 122838
Non-Pressurized Systems



SAE J1527 USCG Type B1-15 SILVERADO 4000

16-337-0560
5/16" I.D.
16-337-0380
3/8" I.D.
Also available in 50' reels.

***** Tanks and Engines for picture purpose only.

① Discount shop pack of 10 - Priced per package



18-9125
OETIKER CLAMP KIT
Replaces: 787133, 787145

Part #	Qty	Johnson/Evinrude #	Oetiker #	Description	
18-9141	1	787145	1410082	Oetiker Jaw Pincers	
Nominal ID					
Part #	Qty	Johnson/Evinrude #	Oetiker #	Inches	mm
18-9126-9	10	346930	16700004	3/8"	9.5
18-9127-9	10	348838	16700006	13/32"	10.5
18-9128-9	10	349516	16700007	7/16"	11.3
18-9129-9	10	347107	16700010	1/2"	13.3
18-9130-9	10	347108	16700011	17/32"	13.8
18-9131-9	10	346931	16700012	35/64"	14
18-9132-9	10	346785	16700013	9/16"	14.5
18-9133-9	10	346786	16700016	5/8"	15.7
18-9134-9	10	348839	16700017	11/16"	17
18-9135-9	10	346151	16700024	13/16"	21
18-9136-9	10	346152	16700031	1"	25.6
18-9137-9	10	346153	16700037	1 3/16"	30.1
18-9138-9	10	349759	16700040	1 1/4"	31.6
18-9139-9	10	349729	16700053	1 5/8"	41
18-9140-9	10	346150	16700020	23/32"	18.5

All clamps are standard package of 10. Each package of 10 is available individually.

PKG. OF 10



SNAPPER CLAMPS

Part No.	Clamp O.E. No.	Range	Size
① 18-8020	322652	.538 - .608	8
① 18-8021	911616	.597 - .665	10
① 18-8034	329654	.670 - .780	12
① 18-8200	322653	.360 - .406	2
① 18-8201	124249	.410 - .468	4
① 18-8202	322654	.475 - .536	6
① 18-8203*	329653	.750 - .875	14
① 18-8204*	324825	.875 - .975	19



56507
LOCTITE® PST 6ML
PIPE SEALANT
Replaces: 910048
(with Teflon®)



18-3001
IMPELLER
Replaces: 277181, 434424



18-3002
IMPELLER
Replaces: 375638, 775518



18-3003
IMPELLER
Replaces: 377178, 775519



18-3006
IMPELLER
Replaces: 378891, 775521



18-3015
IMPELLER
Replaces: 396852, 433935, 797407
With Key
For: 2.5, 3, 4 Ultra, Excel



18-3043
IMPELLER
Replaces: 389642



18-3044
IMPELLER
Replaces: 385072





















18-3050
18-3050-10①
IMPELLER
Replaces: 386084



18-3051
IMPELLER
Replaces: 395289

① This product is priced per piece. To order price per package, please add -9 to the part number.

 <p>18-8904 IMPELLER Replaces: 5031417 Fits: 25-30HP (2000-01, 2004-07), 40-50HP (1999-06)</p>	 <p>18-8906 IMPELLER Replaces: 436137 Fits: 5HP (1996-98), 6-8HP (1991-2005)</p>	 <p>18-8907 IMPELLER Replaces: 5033542 Fits: 90, 115, 140 (2003-06)</p>	
 <p>18-3053-1 IMPELLER Replaces: 396725 Wedge Key</p>	 <p>18-3055 IMPELLER Replaces: 389589</p>	 <p>18-3059 18-3059-10 ① IMPELLER Replaces: 381538, 389289, 394534, 395864, 397131, 435821, 435748, 439948, 5001593 Includes 18-3299 Impeller Key</p>	 <p>18-3082 IMPELLER Replaces: 382547 Slotted Key</p>
 <p>18-3083 IMPELLER Replaces: 377230, 777213</p>	 <p>18-3090 IMPELLER Replaces: 387361, 763735</p>	 <p>18-3091 IMPELLER Replaces: 389576</p>	 <p>18-3099 IMPELLER Replaces: 5033112 For: 4 Stroke 9.9 and 15 HP (2002-up)</p>
 <p>18-3104-1 IMPELLER Replaces: 432941, 437059, 765350</p>	 <p>18-3366 IMPELLER Replaces: 390286</p>	 <p>18-3368 IMPELLER Replaces: 396809</p>	 <p>18-45312 IMPELLER Replaces: 114812 Fits: J/E 2(1993-99), 3(1991-99)</p>
 <p>18-4539 IMPELLER Replaces: 5008967 Fits: 15 (AA-AF), 25 (AA-AF), 30 (AA-AF)</p>	 <p>18-45221 IMPELLER Replaces: 382221 Fits: Johnson Evinrude 1.5/2 hp (1967-84)</p>	 <p>18-3102 IMPELLER PLATE Replaces: 305303</p>	 <p>18-3103 IMPELLER PLATE Replaces: 303069</p>

APPLICATION BEGINS ON PAGE 285

① Discount shop pack of 10 - Priced per package



18-3127
IMPELLER PLATE
Replaces: 319275



18-3182
IMPELLER PLATE
Replaces: 317841



18-3346
CUP & PLATE ASSEMBLY
Replaces: 435027



18-3359
WEAR PLATE
Replaces: 328755



18-3126
WEAR PLATE
Replaces: 321940



18-3178
WEAR PLATE
Replaces: 318995



18-3343
WEAR PLATE
Replaces: 320981



18-3358
INSERT CUP
Replaces: 328751



18-3455
INSERT CUP
Replaces: 340619
For: 40, 50, 25 Jet, 30 Jet 1995-Up,
E-Tec 40/50/60 HP All



18-3179
WATER PUMP CUP
Replaces: 324097



18-3501
DIAPHRAGM & CUP ASSEMBLY
Replaces: 435957
For: 8 (1996-97), 10 (1996-97), 15 (1996-97),
40 (1995-97), 50 (1995-97), 55 (1995-97),
60 (1993-96), 65 (1993-96), 70 (1993-96),
120 (1993-94), 125 (1993-95), 130 (1995-96),
140 (1993-94), 250 (1994-95), 300 (1994-95)



IMPELLER KEYS

Part No.	Replaces	Std. Pkg
18-3295 ③	330619, 344470	3
18-3138 ① ③	334897	2
18-3108	308928	1
18-3299 ③	331107	5
18-3326	300611	1

① Pkg of 2 ② Pkg of 3

APPLICATION BEGINS ON PAGE 285

③ This product is priced per piece. To order priced per package, please add -9 to the part number.



18-3180
WATER PUMP HOUSING
Replaces: 435390



18-3129
WATER PUMP HOUSING
Replaces: 435673, 438591, 436954, 432955



18-3336
WATER PUMP HOUSING
Replaces: 384087



18-3363
WATER PUMP HOUSING
Replaces: 330560



18-3367
WATER PUMP HOUSING
Replaces: 393632



18-3405
WATER PUMP HOUSING
Replaces: 435959

new



18-4568
IMPELLER HOUSING
Replaces: 5007554
Fits: 90 (2013 & Up), 115/130 (2009 & Up)

new



18-4569
IMPELLER HOUSING
Replaces: 339720

new



18-4571
IMPELLER HOUSING
Replaces: 360347
Fits: 200-300HP (2009 & Up)



18-3201
IMPELLER REPAIR KIT
Replaces: 379763

— CONTAINS —



18-3202
IMPELLER REPAIR KIT

— CONTAINS —

Part #	Desc.	O.E. #	Qty.
18-3001	Impeller	277181, 434424	1
NSS	Plate	203132	1

Part #	Desc.	O.E. #	Qty.
18-3001	Impeller	277181, 434424	1
18-3102	Impeller Plate	305303	1



18-3203
IMPELLER REPAIR KIT
Replaces: 379766, 379766

— CONTAINS —

Part #	Desc.	O.E. #	Qty.
18-3002	Impeller	375638	1
18-3103	Impeller Plate	303069	1



18-3210
IMPELLER REPAIR KIT

— CONTAINS —

Part #	Desc.	O.E. #	Qty.
18-3043	Impeller	389642	1
18-2536	Rubber Seal	321120	1
18-2557	Impeller Gasket	324701, 338484	1
18-7158	O-Ring	310967, 310585	1

new



18-8905
IMPELLER REPAIR KIT
Replaces: 5008968
For: 15HP (2011 & Up), 25-30HP (2009, 2011 & Up)

— CONTAINS —

Part #	Desc.	O.E. #	Qty.
18-3295	Key	344470	1
18-4539	Impeller	5008967	1
18-5701	Spring, Pressure Relief	355169	1
18-5703	Spring, Thermostat	355209	1

APPLICATION BEGINS ON PAGE 285

© This product is priced per piece. To order priced per package, please add -9 to the part number.

① 18-3211D



18-3211
IMPELLER REPAIR KIT

— CONTAINS —

Part #	Desc.	O.E. #	Qty.
18-3059	Impeller	395864, 397131, 435821	1
18-2536	Rubber Seal	321120	1
18-2557	Impeller Gasket	324701, 338484	1
18-3299	Impeller Key	331107	1
18-7158	O-Ring	310967, 310585	1
18-3138	Impeller Key	334897	1



18-3238
WATER PUMP KIT

Replaces: 388891

— CONTAINS —

Part #	Desc.	O.E. #	Qty.
18-3051	Impeller	395289	1
18-0446	Water Pump Gasket	323311	1
18-0445	Water Pump Gasket	323312	1
18-2030	Oil Seal	321786	1
18-7105	O-Ring	311338	2
18-3133	Stainless Steel Bolt	331979	4



18-3453
WATER PUMP KIT

With Housing

Replaces: 5006511
For: E-Tec 40/50/60 HP All



18-3454
WATER PUMP KIT

With Housing

Replaces: 438592
For: 40, 50, 25 Jet, 30 Jet 1995-Up
Includes impeller 18-3104-1



18-3325
WATER PUMP KIT

Replaces: 387326

— CONTAINS —

Part #	Desc.	O.E. #	Qty.
18-7134	O-Ring	339543	1
18-3108	Flywheel Key	308928	1
18-3337	Grommet	315837	1
18-3083	Impeller	377230	1
18-3343	Impeller Plate	320981	1
18-2705	Grommet	315748	1



18-3327
WATER PUMP KIT

With Housing

Replaces: 394711, 386697, 391698, 389112, 387610

— CONTAINS —

Part #	Desc.	O.E. #	Qty.
18-3050	Impeller	386084	1
18-3180	Housing	435390	1
18-3178	Wear Plate	318995	1
18-3179	Water Pump Cup	324097	1
18-3329	Grommet	302497	1
18-2392	Grommet	327035	1
18-2025	Oil Seal	318972	1
18-7116	O-Ring	303097	1
18-7139	O-Ring	319085	1
18-3326	Pin	300771	1
18-3369	Stainless Steel Bolt	319126	4



18-3376
WATER PUMP KIT

Without Housing

Replaces: 384956

— CONTAINS —

Part #	Desc.	O.E. #	Qty.
18-3083	Impeller	377230	1
18-3343	Impeller Plate	320981	1
18-3108	Flywheel Key	308928	1
18-3337	Grommet	315837	1
18-7134	O-Ring	339543	1
18-2705	Grommet	315748	1
18-3136	Screw (Long)	324430	2
18-3369	Stainless Steel Bolt	319126	2



18-3377
WATER PUMP KIT

Without Housing

Replaces: 382468

— CONTAINS —

Part #	Desc.	O.E. #	Qty.
18-3002	Impeller	375638	1
18-3103	Impeller Plate	303069	1
18-3329	Water Tube Grommet	302497	1
18-3326	Pin	300771	1

APPLICATION BEGINS ON PAGE 285

① Items ending in "D" are Display Packaged - Regular number is Non-Display



18-3378
WATER PUMP KIT

With Housing

Replaces: 391635, 439077

— CONTAINS —

Part #	Desc.	O.E. #	Qty.
18-3055	Impeller	389589	1
18-3343	Impeller Plate	320981	1
18-3336	Housing	384087	1
18-2709	Wear Plate Gasket	336530	1
18-3365	Stainless Steel Bolt	909533	2
18-3369	Stainless Steel Bolt	319126	2
18-2705	Seal	315748	1
18-3337	Water Tube Grommet	315837	1
18-7134	O-Ring	303059	1



18-3379
WATER PUMP KIT

Without Housing

Replaces: 390381

— CONTAINS —

Part #	Desc.	O.E. #	Qty.
18-3366	Impeller	390286	1
18-3352	Impeller Plate	325398	1
18-3354	Water Pump Gasket	325399	2
18-3332	Grommet	304056	1



18-3380
WATER PUMP KIT

Without Housing

Replaces: 390770

— CONTAINS —

Part #	Desc.	O.E. #	Qty.
18-3055	Impeller	389589	1
18-3343	Impeller Plate	320981	1
18-2709	Wear Plate Gasket	336530	1
18-3365	Stainless Steel Bolt	909533	2
18-3136	Stainless Steel Bolt	319126	2
18-2705	Seal	315748	1
18-3337	Water Tube Grommet	315837	1
18-7134	O-Ring	303059	1



18-3381
WATER PUMP KIT

Without Housing

Replaces: 393509

— CONTAINS —

Part #	Desc.	O.E. #	Qty.
18-3051	Impeller	395289	1
18-3359	Impeller Plate	328755	1
18-0124	Impeller Plate Gasket	325537	1
18-3358	Water Pump Cup	328751	1
18-2539	Rubber Seal	328753	1
18-3329	Grommet	302497	1
18-7100	O-Ring	301877	1
18-7105	O-Ring	311338	2
18-7146	O-Ring	554545	1
18-3133	Stainless Steel Bolt	331979	6



18-3382
WATER PUMP KIT

With Housing

Replaces: 393630

— CONTAINS —

Part #	Desc.	O.E. #	Qty.
18-3051	Impeller	395289	1
18-3359	Impeller Plate	328755	1
18-3367	Housing	393632	1
18-3358	Water Pump Cup	328751	1
18-0124	Impeller Plate Gasket	325537	1
18-3329	Grommet	302497	1
18-7100	O-Ring	301877	1
18-7105	O-Ring	311338	2
18-7146	O-Ring	554545	1
18-3133	Stainless Steel Bolt	331979	6



18-3383
WATER PUMP KIT

With Housing

Replaces: 395270

— CONTAINS —

Part #	Desc.	O.E. #	Qty.
18-3051	Impeller	395289	1
18-3363	Housing	330560	1
18-3358	Water Pump Cup	328751	1
18-3360	Impeller Housing Gasket	329390	1
18-3329	Grommet	302497	1
18-3133	Stainless Steel Bolt	331979	4



18-3384
WATER PUMP KIT
Without Housing
Replaces: 386124

— CONTAINS —

Part #	Desc.	O.E. #	Qty.
18-7158	O-Ring	310585	1
18-3108	Flywheel Key	308928	1
18-3043	Impeller	389642	1
18-3182	Impeller Plate	317841	1
18-2026	Oil Seal	321453	1
18-3135	Screw	306643	2
18-3136	Screw	323626	4
18-2389	Grommet	314832	2



18-3385
WATER PUMP KIT
Without Housing
Replaces: 396932

— CONTAINS —

Part #	Desc.	O.E. #	Qty.
18-3368	Impeller	396809	1
18-3343	Impeller Plate	320981	1
18-2705	Seal	315748	1
18-7481	Rubber Seal	324981	1
18-7134	O-Ring	303059	1
18-3337	Water Tube Grommet	315837	1
18-3365	Stainless Steel Bolt	909533	2
18-3369	Stainless Steel Bolt	319126	2



18-3387
WATER PUMP KIT
Without Housing
Replaces: 432956

— CONTAINS —

Part #	Desc.	O.E. #	Qty.
18-2703	Grommet	314008	1
18-3053-1	Impeller	396725	1
18-2705	Seal	315748	1
18-3133	SS Bolt	331979	4
18-7174	O-Ring	326649	1
18-7481	O-Ring	324981	1
18-2709	Wear Plate Gasket	336530	1
18-3126	Wear Plate	321940	1
18-3127	Impeller Plate	319275	1
18-3138	Impeller Key	334897	1
18-3299	Flywheel Key	331107	1
18-3153	Stainless Steel Bolt	908158	1

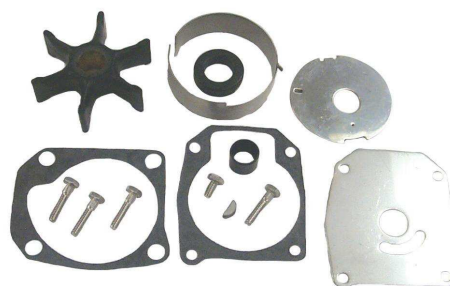

18-3388
WATER PUMP KIT
Without Housing
Replaces: 386533, 389143

— CONTAINS —

Part #	Desc.	O.E. #	Qty.
18-0969	Impeller Housing Gasket	319586	1
18-3108	Stainless Steel Key	323950	1
18-2703	Grommet	314008	1
18-3127	Impeller Plate	319275	1
18-2705	Seal	315748	1
18-3082	Impeller	382547	1
18-3153	Stainless Steel Bolt	334597	1
18-2709	Wear Plate Gasket	336530	1
18-3133	Stainless Steel Bolt	331979	4
18-3126	Wear Plate	321940	1

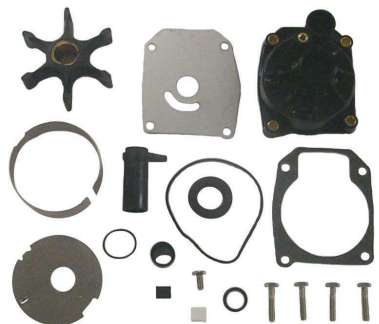

18-3389
WATER PUMP KIT
With Housing
Replaces: 436957, 0438591, 0432955

— CONTAINS —

Part #	Desc.	O.E. #	Qty.
18-7481	O-Ring	324981	1
18-2703	Grommet	314008	1
18-3053-1	Impeller	396725	1
18-3127	Impeller Plate	319275	1
18-2705	Seal	315748	1
18-3133	Stainless Steel Bolt	908158	1
18-3299	Flywheel Key	331107	1
18-7174	O-Ring	326649	1
18-2709	Wear Plate Gasket	336530	1
18-3129	Housing	435673	1
18-3138	Impeller Key	334897	1
18-3126	Wear Plate	321940	1



18-3390
WATER PUMP KIT
Without Housing
Replaces: 395060, 0435447, 0434421, 5001594

— CONTAINS —

Part #	Desc.	O.E. #	Qty.
18-3059	Impeller	397131, 435821	1
18-2557	Impeller Gasket	324701, 338484	1
18-3299	Impeller Key	331107	1
18-7158	O-Ring	310967, 310585	1
18-3135	Stainless Steel Screw	306643	2
18-2703	Grommet	314008	1
18-2704	Grommet	320943	1
18-2706	Grommet	321008	1
18-3136	Stainless Steel Bolt	323626	4
18-2769	Rubber Seal	332000	1
18-3133	Stainless Steel Bolt	331979	4
18-3346	Cup Plate Assy.	435027	1
18-3138	Impeller Key	334897	1



18-3391
WATER PUMP KIT
With Housing
Replaces: 395072

— CONTAINS —

Part #	Desc.	O.E. #	Qty.
18-3346	Cup & Plate Assy.	435027	1
18-2769	O-Ring	332000	1
18-2557	Impeller Plate Gasket	338484, 324701	1
18-2704	Grommet	320943	1
18-3136	Stainless Steel Bolt	323626	4
18-3299	Flywheel Key	331107	1
18-3153	Stainless Steel Bolt	908158	1



18-3392
WATER PUMP KIT
With Housing
Replaces: 434421, 5001594

— CONTAINS —

Part #	Desc.	O.E. #	Qty.
18-3059	Impeller	395864, 397131, 435821	1
18-3346	Cup & Plate Assy.	435027	1
18-3299	Impeller Key	331107	1
18-7158	O-Ring	310967, 310585	1
18-3135	Stainless Steel Screw	306643	2
18-2703	Grommet	314008	1
18-2704	Grommet	320943	1
18-2706	Grommet	321008	1
18-3136	Stainless Steel Bolt	323626	4
18-2769	Rubber Seal	332000	1
18-2557	Impeller Gasket	324701, 338484	1
18-3133	Stainless Steel Bolt	331979	4



18-3393
WATER PUMP KIT
With Housing
Replaces: 395073, 388644

— CONTAINS —

Part #	Desc.	O.E. #	Qty.
18-3043	Impeller	389642	1
18-2557	Impeller Gasket	324701, 338484	1
18-3346	Cup & Plate Assy.	435027	1
18-3108	Water Pump Key	323950	1
18-0110	Shift Housing Gasket	324670	1
18-7158	O-Ring	310967, 310585	1
18-3135	Stainless Steel Screw	306643	2
18-2703	Grommet	314008	1
18-2704	Grommet	320943	1
18-2706	Grommet	321008	1
18-3136	Stainless Steel Bolt	323626	4
18-2769	O-Ring	332000	1
18-7143	O-Ring	322501	1
18-3133	Stainless Steel Bolt	331979	4

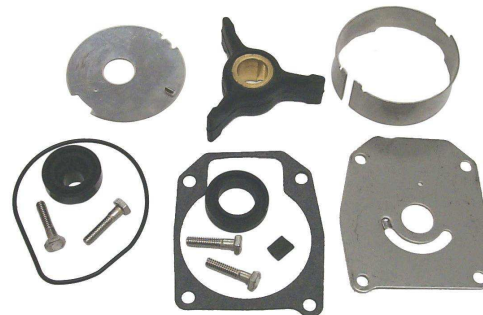

18-3394
WATER PUMP KIT
Without Housing
Replaces: 433548, 0433549, 0438592

— CONTAINS —

Part #	Desc.	O.E. #	Qty.
18-7481	O-Ring	324981	1
18-2708	Grommet	333758	1
18-2709	Wear Plate Gasket	336530	1
18-3104-1	Impeller	432941	1
18-3138	Impeller Key	334897	1
18-2705	Seal	315748	1
18-3133	Stainless Steel Bolt	331979	4
18-3126	Wear Plate	321940	1

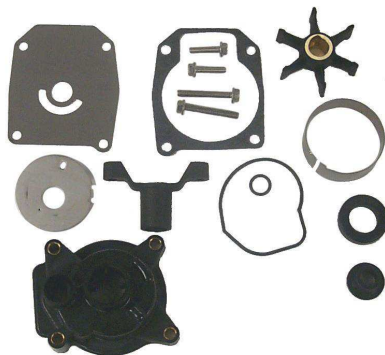

18-3399
WATER PUMP KIT
With Housing
Replaces: 396933, 0439077

— CONTAINS —

Part #	Desc.	O.E. #	Qty.
18-7134	O-Ring	303059	1
18-3337	Grommet	315837	1
18-3368	Impeller	396809	1
18-2709	Wear Plate Gasket	336530	1
18-3369	Screw (Short)	319126	2
18-2705	Seal	315748	1
18-3336	Housing	384087	1
18-3365	Screw (Long)	909533	2
18-3343	Wear Plate	320981	1

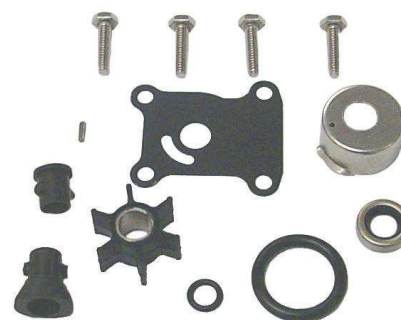

18-3400
WATER PUMP KIT
Without Housing
Replaces: 391698, 0394711

— CONTAINS —

Part #	Desc.	O.E. #	Qty.
18-3050	Impeller	386084	1
18-3178	Impeller Plate	318995	1
18-3179	Water Pump Cup	324097	1
18-3329	Grommet	302497	1
18-2392	Grommet	327035	1
18-2025	Oil Seal	318972	1
18-7116	O-Ring	303097	1
18-3369	Screw	319126	4
18-3326	Pin	300771	1
18-7139	O-Ring	319085	1



18-3401
WATER PUMP KIT

Without Housing

Replaces: 395271, 394394, 0395270

— CONTAINS —

Part #	Desc.	O.E. #	Qty.
18-3051	Impeller	395289	1
18-3360	Gasket	329398	1
18-3358	Cup	328773	1
18-7440-1	O-Ring	301967	2
18-2013	Oil Seal	321786	1
18-3329	Grommet	302497	1
18-0108	Gasket	324449	1
18-3133	Stainless Steel Bolt	331979	4

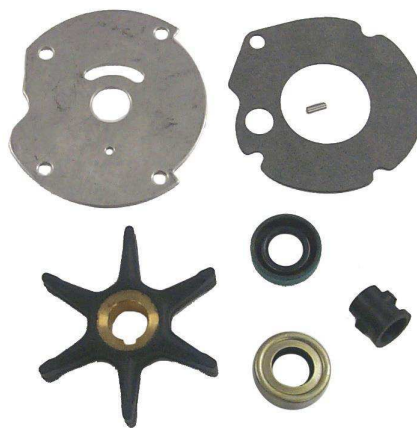

18-3402
WATER PUMP KIT

Without Housing

Replaces: 382296

— CONTAINS —

Part #	Desc.	O.E. #	Qty.
18-3003	Impeller	377178	1
18-3102	Impeller Plate	305303	1
18-2891	Gasket	303339	1
18-3326	Pin	300771	1
18-3329	Grommet	302497	1
18-2023	Oil Seal	313282	1

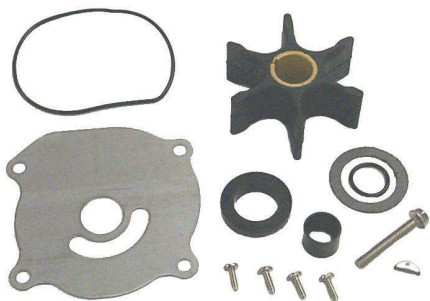

18-3403
WATER PUMP KIT

Without Housing

Replaces: 388644

— CONTAINS —

Part #	Desc.	O.E. #	Qty.
18-7158	O-Ring	310585	1
18-3108	Key	308928	1
18-2703	Grommet	314008	1
18-3135	Screw	306643	4
18-2026	Seal	321453	1
18-3136	Housing Screw	323626	1
18-3043	Impeller	389642	1
18-3346	Cup & Plate Assembly	435027	1
18-2536	Gasket	321120	1
18-2704	Grommet	320943	1



18-3315-2
WATER PUMP KIT

With Housing

Replaces: 435929, 5001595

For: 90/115SL (1995-UP), 120/125ESX (1993-94), 120/130/140/150/175/V-6/V-8(1993-UP)

— CONTAINS —

Part #	Desc.	O.E. #	Qty.
18-2557	Gasket	324701	1
18-3405	Housing, WP	435485	1



18-4537
WATER PUMP KIT

Without Housing

Replaces: 5008972

Fits: 15 (AA-AF), 25 (AA-AF), 30 (AA-AF)

— CONTAINS —

Part #	Desc.	O.E. #	Qty.
18-0124	Gasket	325537	1
18-3359	Plate	328755	1
18-2539	Seal	328753	1
18-3295	Key	344470	1
18-4539	Impeller	5008967	1
18-5701	Spring, Pressure Relief	355169	1
18-5703	Spring, Thermostat	355209	1
18-3358	Cup	328751	1
18-7146	O-Ring	554545	1
18-1595	Screw M6X25	353590	6
18-3367	Housing, Impeller	393632	1
18-2147	Bushing	328754	1
18-3329	Grommet	302497	1
18-7100	O-Ring	301877	1
18-1823	Seal and Pin Assembly	500770	1



18-3472
WATER PUMP KIT

Without Housing

Replaces: 5007972

Fits: 200-300HP (2009 & Up)

— CONTAINS —

Part #	Desc.	O.E. #	Qty.
18-2557	Gasket, Water Pump	338484	1
18-4579	Plate, Outer Wear	338485	1
18-7963	Seal, Impeller Plate	331353	1
18-3059	Impeller	5001593	1
18-71336	O-Ring, Impeller to Plate	302035	1
18-3299	Key, Impeller	331107	1
18-4549	Cup, Insert	338486	1
18-7143	O-Ring, Cup to Housing	331188	1
18-4571	Housing, Impeller	360347	1
18-71338	O-Ring, Water Tube	346865	4
18-9084	Cover, Impeller Housing	354578	1
18-1597	Screw, Housing	302325	4
18-3135	Screw, Cover to Housing	306643	2
18-2704	Grommet, Pump to Exhaust Housing	320943	1
18-1824	Grommet, Sleeve, 20" Models	349354	1
18-1826	Grommet, Sleeve, 25" and 30"	338601	1
18-1822	Sleeve, Extension 25" Models	354580	1

APPLICATION BEGINS ON NEXT PAGE

Ⓢ This product is priced per piece. To order priced per package, please add -9 to the part number.

New



18-3476

WATER PUMP KIT

Without Housing

Replaces: 5007556

Fits: 90 (2013 & Up), 115/130 (2009 & Up)

— CONTAINS —

Part #	Desc.	O.E. #	Qty.
18-2557	Gasket, Plate	338484	1
18-4579	Plate, Outer Wear	338485	1
18-7963	Seal, Housing Plate	331353	1
18-3059	Impeller	5001593	1
18-71336	O-ring, Impeller to Plate	302035	1
18-3299	Key, Impeller	331107	1
18-4549	Cup, Insert	338486	1
18-7143	O-Ring, Cup to Housing	331188	1
18-4568	Housing, Impeller	5007554	1
18-1597	Screw, Housing	302325	4
18-1821	Grommet, Pump to Exhaust Housing	353690	1

New



18-3491

WATER PUMP KIT

Without Housing

Replaces: 437907

Fits: 25/35 (1996-01)

— CONTAINS —

Part #	Desc.	O.E. #	Qty.
18-7100	O-Ring	301877	1
18-0124	Gasket	325537	1
18-1596	Screw	328725	6
18-3358	Cup, Impeller	328751	1
18-2539	Seal	328753	1
18-2147	Bushing, Shift Rod	328754	1
18-3359	Plate, Impeller	328755	1
18-4569	Housing, Impeller	339720	1
18-1825	Grommet	340811	1
18-71340	Seal	342370	1
18-3051	Impeller w/ Key	395289	1
18-7146	O-Ring	554545	1

New

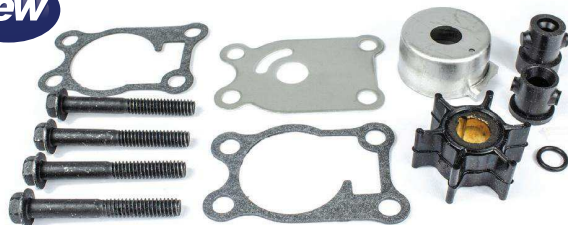

18-4529

WATER PUMP KIT

Without Housing

Replaces: 396644

Fits: 4HP (1986-92), 5HP (1980-83, 1996-01), 6HP (1984-01, 2003-05), 8HP (1980-01, 2003-05)

— CONTAINS —

Part #	Desc.	O.E. #	Qty.
18-3026	Drive Key	331130	1
18-1827	Grommet	321129	1
18-3329	Grommet	302497	1
18-4277	Screws	324430	4
18-4578	Impeller Hsg Plate	324640	1
18-4551	Impeller Hsg Cup	324641	1
18-99156	Impeller Hsg Gasket	325040	2
18-3091	Impeller Assembly	389576	1
18-7413	O-Ring	303191	1

STAINLESS STEEL BOLTS

Part No.	O.E. #	Size
18-3133	330619, 344470	1/4 x 20 x 11/16"
18-3135 ①③	306643	1/8 x 20 x 1/2"
18-3136 ①③	323626	1/4 x 20 x 13/4"
18-3153	908158	1/4 x 20 x 1/2"
18-3365	909533	1/4 x 20 x 1"
18-3369	319126	1/4 x 20 x 1"
18-4276 ②③	324334	1/4 x 20 x 1 1/32"
18-4277 ②③	324430	1/4 x 20 x 2"

① Std. Pkg of 2 ② Std. Pkg of 5

JOHNSON/EVINRUDE WATER PUMP KIT APPLICATION

HP	Year	Impeller	Impeller Plate	Plate & Cup	Cup	Repair Kit	Pump Kit w/o Hsg.	Pump Kit w/Hsg.	Housing Kit
2 Jr, Colt	1985-90	18-3090	—	—	—	—	—	—	—
2.5	1987-06	18-3015	—	—	—	—	—	—	—
3	1952-78	18-3001	—	—	—	18-3201	—	—	—
3.5	1987-06	18-3015	—	—	—	—	—	—	—
4	1969-72	18-3001	—	—	—	18-3201	—	—	—
4 ⑦	1973-83	18-3001	—	—	—	18-3201	—	—	—
4 ⑧	1976-80	18-3090	—	—	—	—	—	—	—
4	1986-92	18-3091	18-4578	—	18-4551	—	18-4529	—	—
4 Deluxe	1980-97	18-3091	—	—	—	—	—	—	—
4 Ultra Excel	1987-06	18-3015	—	—	—	—	—	—	—
4.5	1980-97	18-3091	—	—	—	—	—	—	—
5	1965-68	18-3001	—	—	—	—	—	—	—
5	1980-01	18-3091	18-4578	—	18-4551	—	18-4529	—	—
5 (4-Stroke)	1998-Up	18-3091	—	—	—	—	—	—	—
5.5	1954-64	18-3001	18-3102	—	—	18-3202	—	—	—
6	1952-78	18-3001	18-3102	—	—	18-3202	—	—	—

① Except chrome pumps

② Except SL models 1995 & Up/FFI models

③ "S" Suffix

④ "F" Suffix

⑤ Except 1993-94 25" & 30" V6 & V8

⑦ For water pumps using 1 water tube

⑧ 90 degree gearcase

JOHNSON/EVINRUDE WATER PUMP KIT APPLICATION (CONT.)

HP	Year	Impeller	Impeller Plate	Plate & Cup	Cup	Repair Kit	Pump Kit w/o Hsg.	Pump Kit w/Hsg.	Housing Kit
6	1979	18-3090	—	—	—	—	—	—	—
6	1984-05	18-3091	18-4578	—	18-4551	—	18-4529	—	—
6 (4-Stroke)	1998-Up	18-3091	—	—	—	—	—	—	—
7.5	1954-58	18-3001	18-3102	—	—	18-3202	—	—	—
8	1980-05	18-3091	18-4578	—	18-4551	—	18-4529	—	—
8 (2-Stroke)	1986-97	18-3091	—	—	—	—	—	—	—
9.5	1964-73	18-3003	18-3102	—	—	—	18-3402	—	—
10	1958-63	18-3003	18-3102	—	—	—	18-3402	—	—
10	1949-57	18-3002	18-3103	—	—	18-3203	18-3377	—	—
9.9/15	1974-Up	18-3050	18-3178	—	18-3179	—	18-3400	18-3327	18-3180
9.9/15 (4-Stroke)	1995-Up	18-3050	18-3178	—	18-3179	—	18-3400	18-3327	18-3180
15,18	1953-65	18-3002	—	—	—	18-3203	18-3377	—	—
15	2011 & Up	18-4539	18-3359	—	18-3358	—	—	18-4537	—
15	AA-AF	18-4539	18-3359	—	18-3358	—	—	18-4537	—
20	1966-73	18-3002	—	—	—	18-3203	18-3377	—	—
20	1982-84	18-3051	—	—	18-3358	—	18-3401	18-3383	18-3363
20	1985-Up	18-3051	18-3359	—	18-3358	—	18-3381	18-3382	18-3367
25	1951-55	18-3006	—	—	—	—	—	—	—
25	1969-78	18-3002	18-3103	—	—	18-3203	18-3377	—	—
25	1979-84	18-3051	—	—	18-3358	—	18-3401	18-3383	18-3363
25	1985-Up	18-3051	18-3359	—	18-3358	—	18-3381	18-3382	18-3367
25	1996-01	18-3051	18-3359	—	18-3358	—	18-3491	—	18-4569
25	2011 & Up	18-4539	18-3359	—	18-3358	—	—	18-4537	—
25	AA-AF	18-4539	18-3359	—	18-3358	—	—	18-4537	—
28	1962-64	18-3006	—	—	—	—	—	—	—
28	1978-Up	18-3051	—	—	18-3358	—	18-3401	18-3383	18-3363
30	1951-57	18-3006	—	—	—	—	—	—	—
30	1984-Up	18-3051	18-3359	—	18-3358	—	18-3381	18-3382	18-3367
30	2011 & Up	18-4539	18-3359	—	18-3358	—	—	18-4537	—
30	AA-AF	18-4539	18-3359	—	18-3358	—	—	18-4537	—
33	1962-71	18-3006	—	—	—	—	—	—	—
35	1951-57	18-3006	—	—	—	—	—	—	—
35	1958-59	18-3083	—	—	—	—	—	—	—
35	1976-77	18-3006	—	—	—	—	—	—	—
35	1978-79	18-3051	—	—	—	—	18-3238	—	—
35	1980-82	18-3051	N/A	—	18-3358	—	—	18-3382	18-3367
35	1983-Up	18-3051	18-3359	—	18-3358	—	—	—	—
35	1996-01	18-3051	18-3359	—	18-3358	—	18-3491	—	18-4569
35 Jet	1992-93	18-3104-1	—	—	—	—	18-3394	—	—
40	1960-70	18-3083	—	—	—	—	—	—	—
40	1971-73	18-3006	—	—	—	—	—	—	—
40 Comm.	1981-90	18-3366	18-3352	—	—	—	18-3379	—	—
40	1984-85	18-3055	18-3343	—	—	—	18-3385	18-3399	18-3336
40	1986-88	18-3368	18-3343	—	—	—	18-3385	18-3399	18-3336
40	1989-98	18-3104-1	—	—	—	—	18-3394	—	—
40	1999-Up	18-3053-1	—	—	—	—	18-3394	—	—
45/55 Comm.	1985	18-3055	—	—	—	—	18-3380	—	18-3336
45/55	1989	18-3368	18-3343	—	—	—	18-3385	18-3399	18-3336
45/55 Comm.	1986-88,	18-3368	—	—	—	—	18-3385	18-3399	18-3336
48	1987-88	18-3368	18-3343	—	—	—	18-3385	18-3399	18-3336
48	1989-96	18-3104-1	18-3127	—	—	—	18-3394	—	—
50	1971-78	18-3083	18-3343	—	—	—	18-3376	—	—

① Except chrome pumps ③ "S" Suffix ⑤ Except 1993-94 25" & 30" V6 & V8
 ② Except SL models 1995 & Up/FFI models ④ "F" Suffix ⑦ For water pumps using 1 water tube ⑧ 90 degree gearcase

JOHNSON/EVINRUDE WATER PUMP KIT APPLICATION

HP	Year	Impeller	Impeller Plate	Plate & Cup	Cup	Repair Kit	Pump Kit w/o Hsg.	Pump Kit w/Hsg.	Housing Kit
50	1979-85	18-3055	18-3343	—	—	—	18-3380	18-3378	18-3336
50	1986-88	18-3368	18-3343	—	—	—	18-3385	18-3399	18-3336
50	1989-98	18-3104-1	—	—	—	—	18-3394	—	—
55	1968-69	18-3082	—	—	—	—	—	—	—
55	1976-78	18-3083	—	—	—	—	—	—	18-3336
55	1979-85	18-3055	18-3343	—	—	—	18-3380	18-3378	18-3336
60	1964-67	—	—	—	—	—	—	—	—
60	1970-71	18-3082	—	—	—	—	—	—	—
60	1980-85	18-3055	—	—	—	—	18-3380	18-3378	18-3336
60	1986-94	18-3053-1	18-3127	—	—	—	18-3387	18-3389	—
60	1995-Up	18-3053-1	18-3127	—	—	—	18-3387	—	—
65	1968	—	—	—	—	—	—	—	—
65	1972-73	18-3082	—	—	—	—	—	—	—
65 Comm.	1984-94	18-3053-1	18-3127	—	—	—	18-3387	18-3389	—
65 Comm.	1995-Up	18-3053-1	18-3127	—	—	—	18-3387	—	—
70	1974-78	18-3082	18-3127	—	—	—	18-3388	—	—
70	1979-94	18-3053-1	18-3127	—	—	—	18-3387	18-3389	—
70	1995-Up	18-3053-1	18-3127	—	—	—	18-3387	—	—
75	1960-65	—	—	—	—	—	—	—	—
75	1974-78	18-3082	18-3127	—	—	—	18-3388	—	—
75	1979-88	18-3053-1	18-3127	—	—	—	18-3387	18-3389	18-3129
80	1966-67	—	—	—	—	—	—	—	—
85	1968	—	—	—	—	—	—	—	—
85	1969-72	18-3044	18-3182	—	—	—	—	—	—
85	1973-77	18-3043	18-3182	—	—	—	18-3384	—	—
85	1978	18-3043	—	18-3346	—	—	—	18-3393⑦	18-3391
85	1979-95	18-3059	—	18-3346	—	18-3211	18-3390	18-3392	18-3391
90	1964-68	—	—	—	—	—	—	—	—
90	1979-Up	18-3059	—	18-3346	—	18-3211	18-3390	18-3392②	18-3391
90	2013 & Up	18-3059	18-4579	—	18-4549	—	18-3476	—	18-4568
90 SL,DI	1995 & UP	18-3059	—	18-3346	—	18-3211	18-3390	18-3315-2	18-3405
100	1969-72	18-3044	—	—	—	—	—	—	—
100	1979-Up	18-3059	—	18-3346	—	18-3211	18-3390	18-3392	18-3391
100 Comm. ①	1984-Up	18-3059	—	18-3346	—	18-3211	18-3390	18-3392	18-3391
105 Comm.	1998-2001	18-3059	—	18-3346	—	18-3211	18-3390	18-3315-2	18-3405
115	1969-70	18-3044	—	—	—	—	—	—	—
115	1973-76	18-3043	—	—	—	—	18-3384	—	—
115	1977-78	18-3043	—	18-3346	—	—	—	18-3393⑦	18-3391
115	1979-Up	18-3059	—	18-3346	—	18-3211	18-3390	18-3392②	18-3391
115	2013 & Up	18-3059	18-4579	—	18-4549	—	18-3476	—	18-4568
115 SL,DL	1995 & UP	18-3059	—	18-3346	—	18-3211	18-3390	18-3315-2	18-3405
120 25" ④	1993-2000	18-3059	—	18-3346	—	18-3211	18-3390	18-3315-2	18-3405
125	1971-72	18-3044	—	—	—	—	—	—	—
125 ESX 25" ③	1993-94	18-3059	—	18-3346	—	18-3211	18-3390	18-3392	18-3391
125 ESX 25"	1994-95	18-3059	—	18-3346	—	18-3211	18-3390	18-3392	18-3391
125 ESX 25" ④	1993-94	18-3059	—	18-3346	—	18-3211	18-3390	—	—
130	1997 & UP	18-3059	—	18-3346	—	18-3211	18-3390	18-3315-2	18-3405
130	2013 & Up	18-3059	18-4579	—	18-4549	—	18-3476	—	18-4568
130 25"	1994-2000	18-3059	—	18-3346	—	18-3211	18-3390	18-3315-1	18-3405
135	1973-75	18-3043	18-3182	—	—	18-3210	18-3384	—	—
135	1976	18-3043	18-3182	—	—	—	—	—	—
135 25"	2001	18-3059	—	18-3346	—	18-3211	18-3390	18-3315-2	18-3405

① Except chrome pumps

② Except SL models 1995 & Up/FFI models

③ "S" Suffix

④ "F" Suffix

⑤ Except 1993-94 25" & 30" V6 & V8

⑦ For water pumps using 1 water tube

⑧ 90 degree gearcase

JOHNSON/EVINRUDE WATER PUMP KIT APPLICATION (CONT.)

HP	Year	Impeller	Impeller Plate	Plate & Cup	Cup	Repair Kit	Pump Kit w/o Hsg.	Pump Kit w/Hsg.	Housing Kit
140	1977-78	18-3043	—	18-3346	—	—	—	18-3393⑦	18-3391
140	1979-Up	18-3059	—	18-3346	—	18-3211	18-3390	18-3392	18-3391
140 25" ④	1993	18-3059	—	18-3346	—	18-3211	18-3390	18-3315-2	18-3405
140 25"	1994-2000	18-3059	—	18-3346	—	18-3211	18-3390	18-3315-2	18-3405
150	1976-78	18-3043	—	18-3346	—	18-3210	—	18-3393⑦	18-3391
150	1979-Up	18-3059	—	18-3346	—	18-3211	18-3390	18-3392	18-3391
150 20"	1993 & UP	18-3059	—	18-3346	—	18-3211	18-3390	18-3392	18-3391
150 SL 20"	1994-98	18-3059	—	18-3346	—	18-3211	18-3390	18-3315-2	18-3405
150 EL 20"	1996-98	18-3059	—	18-3346	—	18-3211	18-3390	18-3315-2	18-3405
150 25"	1993 & UP	18-3059	—	18-3346	—	18-3211	18-3390	18-3315-2	18-3405
150 DI	1997 & UP	18-3059	—	18-3346	—	18-3211	18-3390	18-3315-2	18-3405
150	2000 & UP	18-3059	—	18-3346	—	18-3211	18-3390	18-3315-2	18-3405
175	1976-78	18-3043	—	18-3346	—	18-3210	—	18-3393⑦	18-3391
175 SL 20"	1994-98	18-3059	—	18-3346	—	18-3211	18-3390	18-3315-2	18-3405
175 EL 20"	1996-98	18-3059	—	18-3346	—	18-3211	18-3390	18-3315-2	18-3405
175 25"	1993 & UP	18-3059	—	18-3346	—	18-3211	18-3390	18-3315-2	18-3405
175 DI	1997 & UP	18-3059	—	18-3346	—	18-3211	18-3390	18-3315-2	18-3405
175	2000 & UP	18-3059	—	18-3346	—	18-3211	18-3390	18-3315-2	18-3405
200	1976-78	18-3043	—	18-3346	—	—	—	18-3393⑦	18-3391
200	2009 & Up	18-3059	18-4579	—	18-4549	—	18-3472	—	18-4571
200 Comm.	1990	18-3059	—	18-3346	—	18-3211	18-3390	18-3392	18-3391
200 25" & 30"	1993-97	18-3059	—	18-3346	—	18-3211	18-3390	18-3315-2	18-3405
225	2009 & Up	18-3059	18-4579	—	18-4549	—	18-3472	—	18-4571
225 20"	1993 & UP	18-3059	—	18-3346	—	18-3211	18-3390	18-3392	18-3391
225 25" & 30"	1993-97	18-3059	—	18-3346	—	18-3211	18-3390	18-3315-2	18-3405
235	1978	18-3043	—	18-3346	—	—	—	18-3393⑦	18-3391
235	1979-Up	18-3059	—	18-3346	—	18-3211	18-3390	18-3392	18-3391
250	2009 & Up	18-3059	18-4579	—	18-4549	—	18-3472	—	18-4571
275	2009 & Up	18-3059	18-4579	—	18-4549	—	18-3472	—	18-4571
300	2009 & Up	18-3059	18-4579	—	18-4549	—	18-3472	—	18-4571
V4 Cross 20" & 25"	1993 & UP	18-3059	—	18-3346	—	18-3211	18-3390	18-3392	18-3391
V4 Loop 20"	1993 & UP	18-3059	—	18-3346	—	18-3211	18-3390	18-3392	18-3391
V4,V6,V8 ⑤	1982-94	18-3059	—	18-3346	—	18-3211	18-3390	18-3392	18-3391
V6,V8 20"	1993 & UP	18-3059	—	18-3346	—	18-3211	18-3390	18-3392	18-3391
V6 & V8 25" & 30"	1993 & UP	18-3059	—	18-3346	—	18-3211	18-3390	18-3315-2	18-3405
Sea Drives	1979-Up	18-3059	—	18-3346	—	18-3211	18-3390	18-3392⑥	18-3391

① Except chrome pumps

② Except SL models 1995 & Up/FFI models

③ "S" Suffix

④ "F" Suffix

⑤ Except 1993-94 25" & 30" V6 & V8

⑦ For water pumps using 1 water tube

⑧ 90 degree gearcase

18-3563
POPPET
RELIEF VALVE
V-6 Crossflow
Replaces: 321027



18-3564
POPPET
RELIEF VALVE
V-4 Crossflow
Replaces: 318395



18-1219
GROMMET
V-6 Crossflow
Replaces: 320880



PKG. OF 2

18-1221
18-1221-9①
RETAINER GASKET
V-4 / V-6 Loop Charge
Replaces: 330273





18-3562
VALVE CUP
V-6 Crossflow
Replaces: 321222



18-1243
VALVE SPRING
V-4 / V-6 Crossflow
Replaces: 317245



① Priced per Package

 <p>18-1222 THERMOSTAT GASKET V-4 / V-6 Loop Charge Replaces: 394408</p>	 <p>18-3567 RUBBER VALVE V-6 Crossflow Replaces: 321221</p>	 <p>18-3565 RETAINER V-6 Crossflow Replaces: 321220</p>	 <p>18-2391 GROMMET V-4 Crossflow Replaces: 321692</p>												
 <p>18-3500 THERMOSTAT Replaces: 394409, 434137 For: 3 cyl. (1992 & UP), 90° Looper (1990-1992) 140°</p>	 <p>18-3544 THERMOSTAT Replaces: 435491 Fits: E100 (2004-06), E110 (04-06), E115 (2002-06), E75 (2002-03), E90 (2002-03), E150 (1991-94), E175 (1991-94), J105 (2003), J115 (2002-06), J150 (1991-92, 1993-94, 2002-06), J175 (1991-92, 1994, 2002-06), J90 (2004-06)</p>	 <p>18-3545 THERMOSTAT 130° Replace: 437090 Fits: E115 (1997), E135, E150, E175 (2000-06)</p>	 <p>18-3546 THERMOSTAT 130° Replaces: 5001036 Fits: E200, E225, E250 (2000-05), J200, J225, J250 (2000-01)</p>												
 <p>18-3543 THERMOSTAT 143° Replaces: 393659, 434841, 378065, 508626, 5005440 Fits: 40-250hp E-tech, 6-55hp, Cross V4 & V6, 9.9 4-Stroke (1994-01), 15 4-Stroke (1994-01)</p>	 <p>18-3643 THERMOSTAT Replaces: 433379 Fits: 6-8HP (1990), 9.9/15HP (1990-92), 40/48/50HP (1990-94), 45/55 (1992-94)</p>	 <p>18-3557 THERMOSTAT 143° Replaces: 396987, 382385</p>	 <p>18-3561 THERMOSTAT Replaces: 436195 143°</p>												
 <p>18-1506 VERNATHERM 143° Replaces: 394411 For: 10/15 (1993-95), 60/125/185 (1989-90), 65 (1987-89), 70/200/225 (1986-90), 120/140/300 (1985-90), 275 (1985-88)</p>	 <p>18-3560 VERNATHERM Replaces: 384719 105° Fits most 3 & 4 cyl., 1985-90</p>	 <p>18-3669 THERMOSTAT KIT — CONTENTS —</p> <table border="1"> <thead> <tr> <th>Part #</th> <th>Description</th> <th>O.E. #</th> </tr> </thead> <tbody> <tr> <td>18-3557</td> <td>Thermostat</td> <td>396987</td> </tr> <tr> <td>18-2548</td> <td>Thermostat Cover Gasket</td> <td>332108</td> </tr> <tr> <td>18-0929</td> <td>Thermostat Gasket</td> <td>313416</td> </tr> </tbody> </table>	Part #	Description	O.E. #	18-3557	Thermostat	396987	18-2548	Thermostat Cover Gasket	332108	18-0929	Thermostat Gasket	313416	 <p>18-3673D THERMOSTAT KIT V-4 Crossflow Uses thermostat 18-3543</p>
Part #	Description	O.E. #													
18-3557	Thermostat	396987													
18-2548	Thermostat Cover Gasket	332108													
18-0929	Thermostat Gasket	313416													
 <p>18-3674D THERMOSTAT KIT V-6 Crossflow Uses thermostat 18-3543</p>	 <p>18-3566 TELL TALE HOSE ELBOW Replaces: 331894</p>	 <p>18-1507 THERMOSTAT SEAL Replaces: 335981 For: 60° V-4 & V-6</p>	 <p>18-1734 THERMOSTAT SEAL Replaces: 334742 For: OMC thermostat application 6, 8, 10, 15, 40, 48, 50 HP (1989-94)</p>												

APPLICATION ON PAGE 290

① Items ending in "D" are Display Packaged - Regular number is Non-Display

Crossflow V-4 Engine

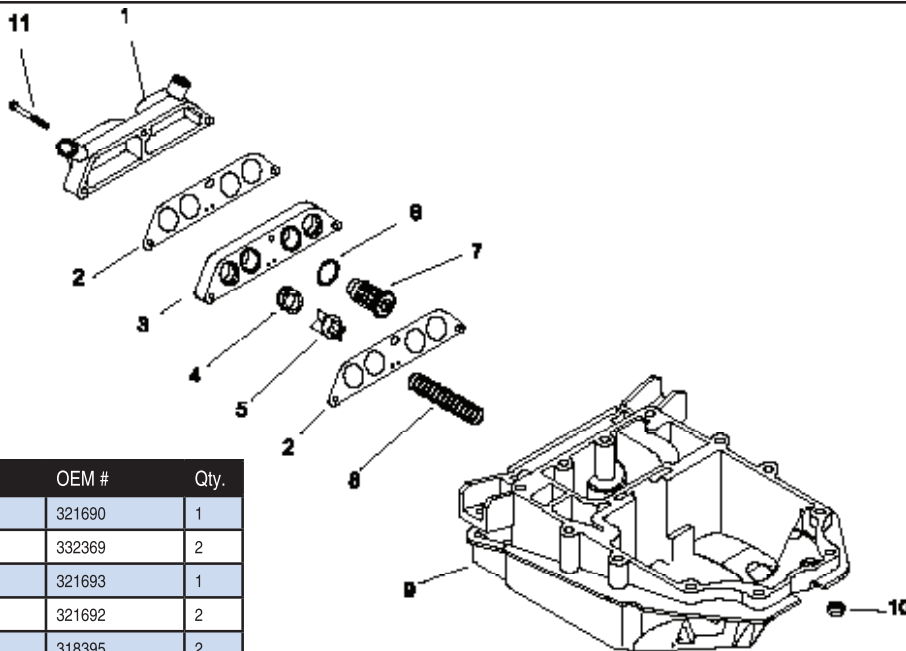

Fig. #	Description	Part #	OEM #	Qty.
1	Cover	~	321690	1
2	Gasket	18-0977	332369	2
3	Valve Body	~	321693	1
4	Grommet	18-2391	321692	2
5	Valve	18-3564	318395	2
6	Thermostat Gasket	18-0675	321932	2
7	Thermostat	18-3543	434841, 393659	2
8	Spring	18-1243	317245	2
9	Adapter	~	331039	1
10	Nut	~	306422	4
11	Screw Cover	~	305652	3

Crossflow V-6 Engine

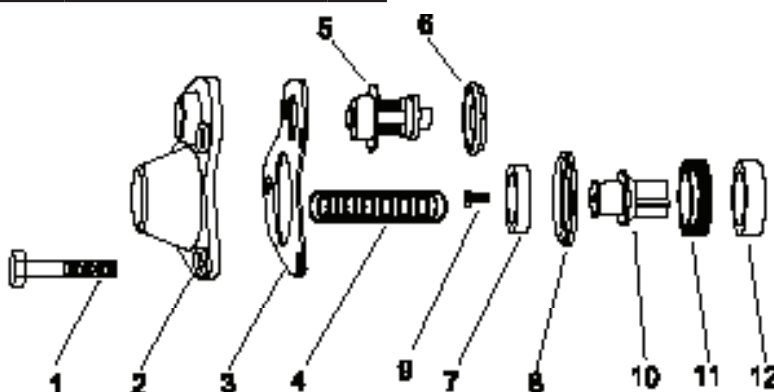

Fig. #	Description	Part #	OEM #	Qty.	Fig. #	Description	Part #	OEM #	Qty.
1	Screw	—	306778	4	7	Retainer	18-3565	321220	1
2	Cover	—	321013	1	8	Seal	18-3567	321221	1
3	Gasket	18-2546	321184	1	9	Stainless Steel Bolt	18-3135	306643	1
4	Spring	18-1243	317245	1	10	Valve	18-3563	321027	1
5	Thermostat	18-3543	393659	1	11	Grommet	18-1219	320880	1
6	Thermostat Gasket	18-0182	310058	1	12	Valve Cap	18-3562	321222	1

JOHNSON/EVINRUDE THERMOSTAT APPLICATION

HP	Years	Thermostat Kit	Thermostat	Valve	Valve Seat	Valve Diaphragm	Valve Retainer	Valve Cup	Valve Spring	Grommet
5	1965-68, 1986	18-3672 ⑤	18-3543	—	—	—	—	—	—	—
5.5	1959-64	18-3672 ⑤	18-3543	—	—	—	—	—	—	—
6	1965-79, 1986	18-3672 ⑤	18-3543	—	—	—	—	—	—	—
6	1990	18-3643	—	—	—	—	—	—	—	—
7.5	1980-86	18-3672 ⑤	18-3543	—	—	—	—	—	—	—
8	1986	18-3672 ⑤	18-3543	—	—	—	—	—	—	—
8	1990	18-3643	—	—	—	—	—	—	—	—
9.5	1964-73	18-3672 ⑤	18-3543	—	—	—	—	—	—	—

① All 1989-91 models except DR & DT
 ② Commercial

③ Commercial also
 ④ Except 60 degree models

⑤ For complete Thermostat Kit including gaskets & spring use 18-3674

APPLICATION CONTINUED ON NEXT PAGE

JOHNSON/EVINRUDE THERMOSTAT APPLICATION

HP	Years	Thermostat Kit	Thermostat	Valve	Valve Seat	Valve Diaphragm	Valve Retainer	Valve Cup	Valve Spring	Grommet
9.9	1974-86	18-3672 ⑤	18-3543	—	—	—	—	—	—	—
9.9	1990-92	18-3643	—	—	—	—	—	—	—	—
10	1959-63	18-3672 ⑤	18-3543	—	—	—	—	—	—	—
15	1974-86	18-3672 ⑤	18-3543	—	—	—	—	—	—	—
15	1990-92	18-3643	—	—	—	—	—	—	—	—
18	1959-73	18-3672 ⑤	18-3543	—	—	—	—	—	—	—
20	1981-94	18-3672 ⑤	18-3543	—	—	—	—	—	—	—
25 ①	1969-94	18-3672 ⑤	18-3543	—	—	—	—	—	—	—
28	1989-94	18-3672 ⑤	18-3543	—	—	—	—	—	—	—
30	1986-94	18-3672 ⑤	18-3543	—	—	—	—	—	—	—
35	1959, 1976-94	18-3672 ⑤	18-3543	—	—	—	—	—	—	—
40	1960-69	18-3672 ⑤	18-3543	—	—	—	—	—	—	—
40	1990-94	18-3643	—	—	—	—	—	—	—	—
45	1989-92 ②	18-3672 ⑤	18-3543	—	—	—	—	—	—	—
45	1992-94	18-3643	—	—	—	—	—	—	—	—
48	1990-94	18-3643	—	—	—	—	—	—	—	—
50	1971-75, 1979, 1981-86	18-3672 ⑤	18-3543	—	—	—	—	—	—	—
50	1990-94	18-3643	—	—	—	—	—	—	—	—
55	1976-92 ③	18-3672 ⑤	18-3543	—	—	—	—	—	—	—
55	1992-94	18-3643	—	—	—	—	—	—	—	—
60	1969-70	18-3669 ⑤	18-3557	—	—	—	—	—	—	—
60	1980-86	18-3672 ⑤	18-3543	—	—	—	—	—	—	—
60, 60TTL	1993	—	18-3561	—	—	—	—	—	—	—
65	1971-73	18-3669	18-3557	—	—	—	—	—	—	—
65	1993	—	18-3561	—	—	—	—	—	—	—
65C	1984-86	18-3669	18-3557	—	—	—	—	—	—	—
65 Jet	1994-95	18-3673	18-3543	18-3564	—	—	—	—	18-1243	18-2391
70	1974-86	18-3669	18-3557	—	—	—	—	—	—	—
70, 70TTL	1993	—	18-3561	—	—	—	—	—	—	—
75	1978-88	18-3669	18-3557	—	—	—	—	—	—	—
80 Jet	1994-95	18-3673	18-3543	18-3564	—	—	—	—	18-1243	18-2391
85	1978-80	18-3673	18-3543	18-3564	—	—	—	—	18-1243	18-2391
85	1993-95	18-3673	18-3543	18-3564	—	—	—	—	18-1243	18-2391
88	1987-95	18-3673	18-3543	18-3564	—	—	—	—	18-1243	18-2391
90 ④	1983-95	18-3673	18-3543	18-3564	—	—	—	—	18-1243	18-2391
90 Jet	1994	18-3673	18-3543	18-3564	—	—	—	—	18-1243	18-2391
100	1979-80	18-3673	18-3543	18-3564	—	—	—	—	18-1243	18-2391
100	1990-95	18-3673	18-3543	18-3564	—	—	—	—	18-1243	18-2391
100 Comm	1984-95	18-3673	18-3543	18-3564	—	—	—	—	—	—
110	1985-89	18-3673	18-3543	18-3564	—	—	—	—	18-1243	18-2391
112	1994-95	18-3673	18-3543	18-3564	—	—	—	—	18-1243	18-2391
115 ④	1978-95	18-3673	18-3543	18-3564	—	—	—	—	18-1243	18-2391
120	1988-91	—	—	—	—	18-1222	—	18-1221	—	—
140	1978-85	18-3673	18-3543	18-3564	—	—	—	—	18-1243	18-2391
140	1988-91	—	—	—	—	18-1222	—	18-1221	—	—
150	1978-91	18-3672 ⑤	18-3543	18-3563	18-1219	18-3567	18-3565	18-3562	18-1243	18-0182
155	1984-91	18-3672 ⑤	18-3543	18-3563	18-1219	18-3567	18-3565	18-3562	18-1243	18-0182
175	1977-91	18-3672 ⑤	18-3543	18-3563	18-1219	18-3567	18-3565	18-3562	18-1243	18-0182
185	1984-85	18-3672 ⑤	18-3543	18-3563	18-1219	18-3567	18-3565	18-3562	18-1243	18-0182
200	1977-83	18-3672 ⑤	18-3543	18-3563	18-1219	18-3567	18-3565	18-3562	18-1243	18-0182
200	1988-93	—	—	—	—	18-1222	18-3565	18-1221	—	—
225	1988-93	—	—	—	—	18-1222	18-3565	18-1221	—	—
235	1978-85	18-3672 ⑤	18-3543	18-3563	18-1219	18-3567	18-3565	18-3562	18-1243	18-0182

① All 1989-91 models except DR & DT
 ② Commercial

③ Commercial also
 ④ Except 60 degree models

⑤ For complete Thermostat Kit including gaskets & spring use 18-3674



Piston Rings are available individually

SIERRA PISTON KIT CONTENTS
(SEE APPLICATION CHARTS FOR SPECIFIC APPLICATIONS)

HP	Cyl.	Bore Size	Piston	OEM Part No.	Piston Ring	OEM Part No.	OEM Part No.	Circlips	OEM Part No.
9.9/15	2	2.188 / std.	—	397487	—	386279	N/A	—	325262
9.9/15	2	2.218 / .030	—	396574	18-3933	386280	N/A	—	325262
9.9/15	2	2.188 / std.	—	387660	—	386279	N/A	—	325262
9.9/15	2	2.218 / .030	18-4062	387661	18-3933	386280	N/A	—	325262
25-35	2	3.000 / std.	18-4107	392621	18-3910	396377	320954	18-4290 ①	317831
25-35	2	3.020 / .020	—	N/A	18-3911	396378	320954	18-4290 ①	317831
25-35	2	3.030 / .030	—	396576	18-3912	396379	320954	18-4290 ①	317831
35-60	2 & 3	3.187 / std.	—	391798	18-3913	391170, 434107	322188	18-4290 ①	317831
35-60	2 & 3	3.207 / .020	—	N/A	18-3914	N/A	322188	18-4290 ①	317831
35-60	2 & 3	3.217 / .030	—	396581	18-3915	391416, 434109	322188	18-4290 ①	317831
60-75	3	3.000 / std.	18-4124	387284	18-3910	396377	320954	18-4290 ①	317831
60-75	3	3.020 / .020	18-4114	387285	18-3911	396378	320954	18-4290 ①	317831
60-75	3	3.030 / .030	18-4104	396583	18-3912	396379	320954	18-4290 ①	317831
50-70	3	3.187 / std.	18-4063	394461	18-3913	391170, 434107	322188	18-4290 ①	317831
50-70	3	3.217 / .030	18-4064	398483	18-3915	391416, 434109	322188	18-4290 ①	317831

SIERRA V-4/V-6 PISTON KIT CONTENTS
(SEE APPLICATION CHARTS FOR SPECIFIC APPLICATIONS)

Model/HP	Cyl.	Bore Size	Piston	OEM Part #	Piston Ring	OEM Part #	Wrist Pin	OEM Part #	Circlips	OEM Part #
85-300	4 & 6	3.5	18-4120	393271, 393924	18-3904	394930	18-4280	327861	18-4290 ①	317831
85-300	4 & 6	3.52	18-4110	—	18-3906	396503, 385662	18-4280	327861	18-4290 ①	317831
85-300	4 & 6	3.53	18-4100	396585, 396588	18-3905	396504	18-4280	327861	18-4290 ①	317831
150-235	4 & 6	3.625	18-4123	392455	18-3907	390509	18-4280	327861	18-4290 ①	317831
150-235	4 & 6	3.645	18-4113	N/A	—	N/A	18-4280	327861	18-4290 ①	317831
150-235	4 & 6	3.655	18-4103	396587	18-3908	390510	18-4280	327861	18-4290 ①	317831

Loopers

120-300	4 & 6	3.685 (port)	18-4065	432072, 432969	18-3975	431870	N.S.S.	—	18-4292	326765
120-300	4 & 6	3.685 (starboard)	18-4066	432073, 432970	18-3975	431870	N.S.S.	—	18-4292	326765
120-300	4 & 6	3.715 (port)	18-4067	432077, 433003	18-3974	431844	N.S.S.	—	18-4292	326765
120-300	4 & 6	3.715 (starboard)	18-4068	432078, 433004	18-3974	431844	N.S.S.	—	18-4292	326765
120-300	4 & 6	3.500 (port)	18-4122	393566	18-3904	394930	18-4280	327861	18-4290 ①	317831
120-300	4 & 6	3.500 (starboard)	—	391481	18-3904	394930	18-4280	327861	18-4290 ①	317831
120-300	4 & 6	3.520 (port)	—	N/A	18-3906	396503, 385662	18-4280	327861	18-4290 ①	317831
120-300	4 & 6	3.520 (starboard)	18-4111	N/A	18-3906	396503, 385662	18-4280	327861	18-4290 ①	317831
120-300	4 & 6	3.530 (port)	18-4102	393612	18-3905	396504	18-4280	327861	18-4290 ①	317831
120-300	4 & 6	3.530 (starboard)	18-4101	391653	18-3905	396504	18-4280	327861	18-4290 ①	317831
185, 200-225	6	3.5995 (port)	standard 18-4190	436860	18-3901	436254	—	—	—	—
185, 200-225	6	3.5995 (starboard)	standard 18-4079	436859	18-3901	436254	—	—	—	—
185, 200-225	6	3.5995 (port)	0.02 18-4195	439015	18-3947	439538	—	—	—	—
185, 200-225	6	3.5995 (starboard)	0.02 18-4086	439516	18-3947	439538	—	—	—	—
185, 200-225	6	3.5995 (port)	0.03 18-4165	439515	—	439538	—	—	—	—
185, 200-225	6	3.5995 (starboard)	0.03 18-4087	439515	—	439538	—	—	—	—

① This product is priced per piece. To order priced per package, please add -9 to the part number.

INLINE PISTON & RINGS APPLICATION									
HP	Year	Cyl	Std. Bore	Std. Piston	.020 OS Piston	.030 OS Piston	Std. Rings	.020 OS Rings	.030 OS Rings
5/6/8/7.5	1986-95	2	1.937	18-4069	—	—	18-3972	—	—
9.9/15	1974-80	2	2.188	—	—	18-4062	—	—	18-3933
9.9/15	1981-93	2	2.188	—	—	—	—	—	18-3933
10	1988-90	2	2.188	—	—	—	—	—	18-3933
14	1988-90	2	2.188	—	—	—	—	—	18-3933
15 4-Stroke	1995-UP	2	2.188	—	—	—	—	—	18-3933
18 Jet	1995-98	2	3	18-4107	—	—	18-3910	18-3911	18-3912
20	1981-99	2	3	18-4107	—	—	18-3910	18-3911	18-3912
25	1977-80	2	3	—	—	—	18-3910	18-3911	18-3912
25	1981-96	2	3	18-4107	—	—	18-3910	18-3911	18-3912
25	1983-93	2	3.187	—	—	—	18-3913	18-3914	18-3915
28	1986-96	2	3	18-4107	—	—	18-3910	18-3911	18-3912
28 Jet	1995-96	2	3.187	—	—	—	18-3913	18-3914	18-3915
30	1984-98	2	3	18-4107	—	—	18-3910	18-3911	18-3912
35	1976-80	2	3	—	—	—	18-3910	18-3911	18-3912
35	1981-92	2	3	18-4107	—	—	18-3910	18-3911	18-3912
35	1986-87	2	3.187	—	—	—	18-3913	18-3914	18-3915
35 Jet	1990-98	2	3.187	—	—	—	18-3913	18-3914	18-3915
40	1975-83	2	3.187	—	—	—	18-3913	18-3914	18-3915
40	1984-98	2	3.187	—	—	—	18-3913	18-3914	18-3915
40 Comm.	1981-97	2	3.187	—	—	—	18-3913	18-3914	18-3915
45 Comm.	1985-92	2	3.187	—	—	—	18-3913	18-3914	18-3915
45SS	1987-90	2	3.187	—	—	—	18-3913	18-3914	18-3915
48	1987-97	2	3.187	—	—	—	18-3913	18-3914	18-3915
50	1981-95	2	3.187	—	—	—	18-3913	18-3914	18-3915
50	1995-98	3	3.187	18-4063	—	18-4064	18-3913	18-3914	18-3915
55	1976-79	2	3.187	—	—	—	18-3913	18-3914	18-3915
55 Comm.	1980-95	2	3.187	—	—	—	18-3913	18-3914	18-3915
60	1980-85	2	3.187	—	—	—	18-3913	18-3914	18-3915
60 (49 CID Model)	1986-88	3	3	18-4124	18-4114	18-4104	18-3910	18-3911	18-3912
60	1986-98	3	3.187	18-4063	—	18-4064	18-3913	18-3914	18-3915
65, 65 Comm.	1972-73	3	3	—	—	—	18-3910	18-3911	18-3912
49 CID Model	1984-86	3	3	18-4124	18-4114	18-4104	18-3910	18-3911	18-3912
65	1987-95	3	3.187	18-4063	—	18-4064	18-3913	18-3914	18-3915
65 Jet	1991-95	4	3.5	18-4120	18-4110	18-4100	18-3904	18-3906	18-3905
70	1974-75	3	3	—	—	—	18-3910	18-3911	18-3912
70	1976-85	3	3	18-4124	18-4114	18-4104	18-3910	18-3911	18-3912
70	1986-94	3	3.187	18-4063	—	18-4064	18-3913	18-3914	18-3915
75	1975	3	3	—	—	—	18-3910	18-3911	18-3912
75	1976-88	3	3	18-4124	18-4114	18-4104	18-3910	18-3911	18-3912

JOHNSON/EVINRUDE PISTONS (for V-4, V-6 and V-8 Applications)

HP	Cyl	Year	Std. Bore	STANDARD		.020" OS		.030" OS		Piston Rings	.020 OS Rings	.030 OS Rings	Powerhead Bearing Set
				Port	STBD	Port	STBD	Port	STBD				
65 Jet	4	1991-95	3.5	18-4120	18-4120	18-4110	18-4110	18-4100	18-4100	18-3904	18-3906	18-3905	18-1386
80 Jet	4	1991-96	3.5	18-4120	18-4120	18-4110	18-4110	18-4100	18-4100	18-3904	18-3906	18-3905	—
85	4	1979-80, 1991-95	3.5	18-4120	18-4120	18-4110	18-4110	18-4100	18-4100	18-3904	18-3906	18-3905	18-1386
88	4	1987-95	3.5	18-4120	18-4120	18-4110	18-4110	18-4100	18-4100	18-3904	18-3906	18-3905	18-1386
90	4	1981-98	3.5	18-4120	18-4120	18-4110	18-4110	18-4100	18-4100	18-3904	18-3906	18-3905	18-1386
100 ①	4	1979-97	3.5	18-4120	18-4120	18-4110	18-4110	18-4100	18-4100	18-3904	18-3906	18-3905	18-1386
110	4	1986-90	3.5	18-4120	18-4120	18-4110	18-4110	18-4100	18-4100	18-3904	18-3906	18-3905	18-1386
115	4	1974-77	3.5	18-4120	18-4120	18-4110	18-4110	18-4100	18-4100	18-3904	18-3906	18-3905	—
115	4	1978-98	3.5	18-4120	18-4120	18-4110	18-4110	18-4100	18-4100	18-3904	18-3906	18-3905	18-1386

① Except 1991 60° V Models

JOHNSON/EVINRUDE PISTONS (for V-4, V-6 and V-8 Applications) (Cont.)

HP	Cyl	Year	Std. Bore	STANDARD		.020" OS		.030" OS		Piston Rings	.020 OS Rings	.030 OS Rings	Powerhead Bearing Set
				Port	STBD	Port	STBD	Port	STBD				
120	4	1985-87	3.5	—	—	—	18-4111	18-4102	18-4101	18-3904	18-3906	18-3905	—
120	4	1988-94	3.685	18-4065	18-4066	—	—	18-4067	18-4068	18-3975	—	—	—
125 Comm.	4	1992-95	3.685	18-4065	18-4066	—	—	18-4067	18-4068	18-3975	—	—	—
130	4	1995-98	3.685	18-4065	18-4066	—	—	18-4067	18-4068	18-3975	—	—	—
135	4	1974-76	3.5	18-4120	18-4120	18-4110	18-4110	18-4100	18-4100	18-3904	18-3906	18-3905	—
140	4	1977	3.5	18-4120	18-4120	18-4110	18-4110	18-4100	18-4100	18-3904	18-3906	18-3905	—
140	4	1978-84	3.5	18-4120	18-4120	18-4110	18-4110	18-4100	18-4100	18-3904	18-3906	18-3905	18-1386
140	4	1985-87	3.5	—	—	—	18-4111	18-4102	18-4101	18-3904	18-3906	18-3905	—
140	4	1988-94	3.685	18-4065	18-4066	—	—	18-4067	18-4068	18-3975	—	—	—
1600CC	4	1988	3.5	18-4120	18-4120	18-4110	18-4110	18-4100	18-4100	18-3904	18-3906	18-3905	18-1386
150	6	1973-77	3.5	18-4120	18-4120	18-4110	18-4110	18-4100	18-4100	18-3904	18-3906	18-3905	—
150	6	1978-91	3.5	18-4120	18-4120	18-4110	18-4110	18-4100	18-4100	18-3904	18-3906	18-3905	—
155 Comm.	6	1984-92	3.5	18-4120	18-4120	18-4110	18-4110	18-4100	18-4100	18-3904	18-3906	18-3905	—
175	6	1977-83	3.5	18-4120	18-4120	18-4110	18-4110	18-4100	18-4100	18-3904	18-3906	18-3905	—
175	6	1986-91	3.625	18-4123	18-4123	18-4113	18-4113	—	—	18-3907	—	18-3908	—
185	6	1984-85	3.5	18-4120	18-4120	18-4110	18-4110	18-4100	18-4100	18-3904	18-3906	18-3905	—
185	6	1990-93	—	—	—	—	—	—	—	—	—	—	18-1389
185 Looper	6	1993-94	3.5995	18-4190	18-4079	18-4195	18-4086	18-4165	—	—	—	—	—
200	6	1976-83	3.5	18-4120	18-4120	18-4110	18-4110	18-4100	18-4100	18-3904	18-3906	18-3905	18-1389
200	6	1985-87	3.5	—	—	—	18-4111	18-4102	18-4101	18-3904	18-3906	18-3905	—
200 ①	6	1988-93	3.685	18-4065	18-4066	—	—	18-4067	18-4068	18-3975	—	—	18-1389
200-225 Looper	6	1993-01	3.5995	18-4190	18-4079	18-4195	18-4086	18-4165	18-4087	—	—	—	—
225	6	1985-87	3.5	—	—	—	18-4111	18-4102	18-4101	18-3904	18-3906	18-3905	18-1389
225	6	1988-93	3.685	18-4065	18-4066	—	—	18-4067	18-4068	18-3975	—	—	18-1389
235	6	1980-85	3.625	18-4123	18-4123	18-4113	18-4113	18-4103	18-4103	18-3907	—	18-3908	—
250/300	6	1990-93	3.685	18-4065	18-4066	—	—	18-4067	18-4068	18-3975	—	—	—
2500CC	6	1988	3.5	18-4120	18-4120	18-4110	18-4110	18-4100	18-4100	18-3904	18-3906	18-3905	—
250	6	1988-92	3.685	18-4065	18-4066	—	—	18-4067	18-4068	18-3975	—	—	—
275	8	1988-92	3.685	18-4065	18-4066	—	—	18-4067	18-4068	18-3975	—	—	—
275	8	1985-87	3.5	—	—	—	18-4111	18-4102	18-4101	18-3904	18-3906	18-3905	—
300	8	1988-92	3.685	18-4065	18-4066	—	—	18-4067	18-4068	18-3975	—	—	—
300/3.6L	8	1985-87	3.5	—	—	—	18-4111	18-4102	18-4101	18-3904	18-3906	18-3905	—

60° Eagle Series

HP	Cyl.	Bore Size	Piston	OE No.	Piston Ring	OE No.
90-175	4 & 6	3.600 (port)	—	436242	18-4088	436353
90-175	4 & 6	3.600 (starboard)	—	436243	18-4088	436353
90-175	4 & 6	3.620 (port)	—	N/A	18-4089	N/A
90-175	4 & 6	3.620 (starboard)	—	N/A	18-4089	N/A
90-175	4 & 6	3.630 (port)	—	439519	18-4090	436354

OMC V-4/V-6 60° Eagle Series Pistons

H.P.	YEAR	CYL.	STD. BORE	STANDARD		.020" O.S.		.030" O.S.		STD. RINGS	.030" O.S. Rings
				(PORT)	(STBD)	(PORT)	(STBD)	(PORT)	(STBD)		
90-175	1991-2000	4 & 6	3.600	—	—	—	—	18-4058	—	18-4088	18-4090

OMC SEA DRIVE PISTONS

H.P.	YEAR	CYL.	STD. BORE	STANDARD		.020" O.S.		.030" O.S.		STD. RINGS	.020" O.S. RINGS	.030" O.S. RINGS
				(PORT)	(STBD)	(PORT)	(STBD)	(PORT)	(STBD)			
1.6L	1983-89	4	3.500	18-4120	18-4120	18-4110	18-4110	18-4100	18-4100	18-3904	18-3906	18-3905
1.8L	1987	4	3.500	—	—	—	18-4111	18-4102	18-4101	18-3904	18-3906	18-3905
2.5L	1982, 1984-85	6	3.500	18-4120	18-4120	18-4110	18-4110	18-4100	18-4100	18-3904	18-3906	18-3905
2.6L	1982-86	6	3.625	18-4123	18-4123	18-4113	18-4113	—	—	18-3907	—	18-3908
2.7L	1987	6	3.500	—	—	—	18-4111	18-4102	18-4101	18-3904	18-3906	18-3905
3.6L	1987	8	3.500	—	—	—	18-4111	18-4102	18-4101	18-3904	—	18-3905

**ORIGINAL EQUIPMENT MANUFACTURER RECOMMENDS THE REPLACEMENT OF
ROD BOLTS WITH EVERY POWER HEAD REBUILD.**



ROD BOLTS

Part #	OE#	Application
18-4075	308186	For V-4 & V-6 Crossflow engines
18-4075-9 ^{①②}	308186	For V-4 & V-6 Crossflow engines
18-4076	330081	For V-4 Looper engines



**18-1752
CONNECTING ROD**

Replaces: 394462
For: 40HP (1999-01), 50HP (1995-98), 60HP (1989-01), 70HP (1986-01)



**18-1753
CONNECTING ROD**

Replaces: 395861
For: 30HP (1999-01), 40 HP (1985-02), 45HP (1986-87, 1990-97), 48HP (1987-96), 50HP (1985-02), 55HP (1985-93, 1999-01), 60 HP (1985)



**18-4148-1
CONNECTING ROD**

Replaces: 394488, 5004705
For: V-4 Looper engines and some V-6 applications



**18-4197
CRANKSHAFT**

Replaces: 334665
3 Cylinder Looper
Year **HP**
1989-92 60
1989-92 65 Comm
1989-95 70



**18-1352
CENTER MAIN
BEARING**

Replaces: 378252



**18-1353
CENTER MAIN
BEARING**

Replaces: 387041



**18-1360
ROD BEARING**

Replaces: 396041



**18-1361
ROD CRANK END
BEARING**

Replaces: 387787



**18-1378
ROD BEARING**

Replaces: 388344



**18-1374
WRIST PIN
BEARING**

Replaces: 395627



**18-1376
WRIST PIN BEARING**

Replaces: 434844



**18-1377
CENTER MAIN
BEARING**

Replaces: 320499



**18-4712
SLEEVE**

I.D. 3.1875 • O.D. 3.453 • Wall 0.125 • Length 5.556
Replacement straight sleeve with ports cutin

APPLICATION BEGINS ON NEXT PAGE

① Priced per Package

② Package of 12



18-4040
NEEDLE BEARINGS
 (18 Needles)
 Replaces: 387142, 387139
 (Crank End)
 (Must re-use cage)



POWERHEAD BEARINGS

Part #	Replaces:	Description
18-1391	330854	Lower Crankshaft Bearing
18-1393	393896	Upper Crankshaft Bearing
18-1395	385503	Lower Crankshaft Bearing
18-1396	390641	Lower Crankshaft Bearing

POWERHEAD BEARING KITS

18-1386

Contains

Part No.	Bearing Type	OE No.	Qty.
18-1353	Ctr. Main	387041	1
18-1377	Ctr. Main	320499	1
18-1374	Wrist Pin	395627	4
18-1395	Lower Crankshaft	385503	1
18-1361	Rod Crank End	387787	4



18-1389

Contains

Part No.	Bearing Type	OE No.	Qty.
18-1353	Ctr. Main	387041	2
18-1377	Ctr. Main	320499	2
18-1376	Wrist Pin	434844	6
18-1396	Lower Crankshaft	390641	1
18-1360	Rod	396041	4



HP	Year	Sleeve	Connecting Rod	Rod Bolt	Wrist Pin Brg.	Rod Brg. Complete	Rod Brgs.	Center Main Brg.	Split Brg. (sleeve)	Upper Crank Brg.	Lower Crank Brg.	Powerhead Brg. Kit
2 CYLINDER												
9.9	1974-83	-	-	-	-	-	-	-	-	-	-	-
9.9	1974-83	-	-	-	-	-	-	-	-	-	-	-
9.9	1974-80	-	-	-	-	-	-	-	-	-	-	-
9.9	1981-83	-	-	-	-	-	-	-	-	-	-	-
9.9	1986-92	-	-	-	-	-	-	-	-	-	-	-
9.9	1984-97	-	-	-	-	-	-	-	-	-	-	-
9.9	1998	-	-	-	-	-	-	-	-	-	-	-
14 Comm	1988-89	-	-	-	-	-	-	-	-	-	-	-
15	1974-83	-	-	-	-	-	-	-	-	-	-	-
15	1984-97	-	-	-	-	-	-	-	-	-	-	-
15 Comm	1994	-	-	-	18-1296	-	-	-	-	-	-	-
18	1960-68	-	-	-	-	-	18-4040	-	-	-	-	-
18	1970-73	-	-	-	-	-	18-4040	-	-	-	-	-
18 Jet	1996-97	-	-	-	18-1374	18-1378	-	-	-	18-1393	18-1391	-
20	1981-84	-	-	-	18-1374	18-1378	18-4040	-	-	-	18-1391	-
20	1985-97	-	-	-	18-1374	18-1378	-	-	-	18-1393	18-1391	-
25	1970-76	-	-	-	-	-	18-4040	-	-	-	-	-
25	1977	-	-	-	-	18-1378	18-4040	-	-	-	18-1391	-
25	1978-80	-	-	18-4075	-	18-1378	18-4040	-	-	-	18-1391	-
25	1981-84	-	-	-	18-1374	18-1378	18-4040	-	-	18-1391	18-1391	-
25 ①	1985-97	-	-	-	-	-	-	-	-	18-1393	18-1391	-
25	1985-97	-	-	18-4075	18-1374	18-1378	-	-	-	-	-	-
25 Comm	1982-84	-	-	-	18-1374	18-1378	18-4040	-	-	-	18-1391	-
25 Comm	1985-97	-	-	-	18-1374	18-1378	-	-	-	18-1393	18-1391	-
28	1987-97	-	-	-	18-1374	18-1378	-	-	-	18-1393	18-1391	-
30	1981-93	-	-	18-4075	18-1374	18-1378	18-4040	-	-	-	-	-
30	1984-1992	-	-	18-4075	-	18-1378	18-4040	-	-	-	-	-
30	1985-97	-	-	-	18-1374	18-1378	18-4040	-	-	18-1393	18-1391	-
30	1984	-	-	-	-	18-1378	18-4040	-	-	-	18-1391	-
33	1965-69	-	-	-	-	18-1378	18-4040	-	-	-	-	-
33	1970	-	-	-	-	18-1378	18-4040	-	-	-	-	-

① Except "D" Models
 ② Two Cylinder Models

③ Three Cylinder Models
 ④ 90 Degree Models

⑤ 60 Degree Models
 ⑥ V-4, V-6 & V-8 Model engines do not include upper bearings in kits

APPLICATION CONTINUED ON NEXT PAGE

HP	Year	Sleeve	Connecting Rod	Rod Bolt	Wrist Pin Brg.	Rod Brg. Complete	Rod Brgs.	Center Main Brg.	Split Brg. (sleeve)	Upper Crank Brg.	Lower Crank Brg.	Powerhead Brg. Kit
35	1976-80	-	-	-	-	18-1378	18-4040	-	-	-	18-1391	-
35	1981-84	-	-	18-4075	18-1374	-	18-4040	-	-	-	18-1391	-
35	1985-97	-	-	-	18-1374	18-1378	-	-	-	18-1393	18-1391	-
35	1976-1993	-	-	18-4075	18-1374	18-1378	-	-	-	-	-	-
35	1977	-	-	18-4075	-	-	-	-	-	-	-	-
35	1978-1980	-	-	18-4075	-	18-1378	18-4040	-	-	-	18-1391	-
35	1981-1993	-	-	18-4075	18-1374	18-1378	-	-	-	18-1393	18-1391	-
40	1984-92	18-4712	-	18-4075	18-1374	18-1378	-	18-1352	-	-	18-1391	-
40	1961-70	-	-	-	-	-	18-4040	-	-	-	-	-
40	1971-73	-	-	-	-	18-1378	18-4040	-	-	-	-	-
40	1974-76	-	-	-	-	18-1378	18-4040	18-1352	-	-	18-1154	-
40	1984-86	-	-	-	18-1374	18-1378	-	18-1352	-	18-1372	18-1154	-
40	1987-97	-	-	-	18-1374	18-1378	-	18-1352	-	-	18-1154	18-1389
40	1983	-	-	18-4075	-	-	-	18-1352	-	-	18-1154	-
40 Comm	1982-83	-	-	-	-	18-1378	-	18-1352	-	-	-	-
40 Comm	1984-85	-	-	-	-	18-1378	-	18-1352	-	18-1372	-	-
40 Comm	1989-90	-	-	-	-	18-1378	-	18-1352	-	-	-	-
40 Comm	1994	-	-	-	18-1374	18-1378	-	18-1352	-	-	-	-
40 Comm	1995-97	-	-	-	18-1374	-	-	18-1352	-	-	-	-
45 Comm	1985-86	-	-	-	18-1374	18-1378	-	18-1352	-	18-1372	-	-
45 Comm	1987-94	-	-	-	18-1374	18-1378	-	18-1352	-	18-1372	-	-
45 Comm	1995-97	-	-	-	18-1374	-	-	18-1352	-	-	-	-
45 Comm	1987	-	-	-	18-1374	18-1378	-	18-1352	-	-	18-1154	-
45ss	1987-90	-	-	-	18-1374	18-1378	-	18-1352	-	18-1372	-	-
48	1987	18-4712	-	-	18-1374	18-1378	-	18-1352	-	18-1372	-	-
48	1987-92	18-4712	-	18-4075	18-1374	18-1378	-	18-1352	-	-	-	-
48	1988-96	-	-	-	18-1374	18-1378	-	18-1352	-	-	-	-
50	1979-83	18-4712	-	18-4075	18-1374	18-1378	18-4040	18-1352	-	18-1372	-	-
50	1979-86	-	-	-	18-1374	18-1378	-	18-1352	-	18-1372	-	-
50	1981-93	18-4712	-	18-4075	18-1374	18-1378	-	18-1352	-	-	-	-
50i	1987-97	-	-	-	18-1374	18-1378	-	18-1352	-	-	-	-
50i	1995-97	-	-	-	18-1374	18-1378	-	18-1352	-	-	-	-
55	1968-69	-	-	-	-	18-1378	18-4040	18-1352	-	-	-	-
55	1976-81	-	-	-	18-1374	18-1378	18-4040	18-1352	-	18-1372	-	-
55 Comm	1982	-	-	-	18-1374	18-1378	18-4040	18-1352	-	18-1372	-	-
55 Comm	1983-86	-	-	-	18-1374	18-1378	-	18-1352	-	18-1372	-	-
55 Comm	1987-94	-	-	-	18-1374	18-1378	-	18-1352	-	-	-	-
55 Comm	1995-97	-	-	-	18-1374	18-1378	-	18-1352	-	-	-	-
55	1978-93	18-4712	-	18-4075	-	-	-	-	-	-	-	-
60	1980-85	18-4712	-	18-4075	18-1374	18-1378	-	18-1352	-	18-1372	-	-
60	1964-67,70-71	-	-	-	-	18-1378	18-4040	18-1352	-	-	-	-
60	86-90	-	-	-	18-1374	18-1378	-	18-1352	-	18-1372	-	-
60	1991-93	-	-	-	18-1374	18-1378	-	18-1352	-	-	-	-
60	1994-97	-	-	-	18-1374	-	-	18-1352	-	-	-	-
SST-60	1989-90	-	-	-	18-1374	18-1378	-	18-1352	-	18-1372	-	-
3 Cylinder												
60	1985	-	-	18-4075	18-1374	18-1378	18-4040	18-1352	-	18-1372	-	-
60	1986-90	-	-	-	18-1374	18-1378	18-4040	18-1352	-	18-1372	-	-
60	1986-88	-	-	18-4075	18-1374	18-1378	18-4040	18-1352	-	18-1372	-	-
60	1989-92	-	-	18-4075	18-1374	18-1378	18-4040	18-1352	-	-	-	-
65	1968	-	-	-	-	18-1378	18-4040	18-1352	-	-	-	-
65	1972-73	-	-	-	-	18-1378	18-4040	18-1352	-	18-1372	-	-

① Except "D" Models
② Two Cylinder Models

③ Three Cylinder Models
④ 90 Degree Models

⑤ 60 Degree Models
⑥ V-4, V-6 & V-8 Model engines do not include upper bearings in kits

APPLICATION CONTINUED ON NEXT PAGE

HP	Year	Sleeve	Connecting Rod	Rod Bolt	Wrist Pin Brg.	Rod Brg. Complete	Rod Brgs.	Center Main Brg.	Split Brg. (sleeve)	Upper Crank Brg.	Lower Crank Brg.	Powerhead Brg. Kit
65 Comm	1984	-	-	-	18-1374	18-1378	18-4040	18-1352	-	18-1372	-	-
65 Comm	1985-90	-	-	-	18-1374	18-1378	18-4040	18-1352	-	18-1372	-	-
65 Comm	1991-93	-	-	-	18-1374	18-1378	18-4040	18-1352	-	-	-	-
65 Comm.	1994-97	-	-	-	18-1374	18-1378	18-4040	18-1352	-	-	-	-
65	1984-86	-	-	18-4075	18-1374	18-1378	18-4040	18-1352	-	18-1372	18-1154	-
70	1976-85	-	-	18-4075	18-1374	18-1378	18-4040	18-1352	-	18-1372	18-1154	-
70	1974-75	-	-	-	-	18-1378	18-4040	18-1352	-	18-1372	-	-
70	1976-90	-	-	-	18-1374	18-1378	18-4040	18-1352	-	18-1372	18-1154	-
70	1976-84	-	-	18-4075	18-1374	18-1378	18-4040	18-1352	-	18-1372	18-1154	-
70	1985-90	-	-	-	18-1374	18-1378	18-4040	18-1352	-	18-1372	18-1154	-
70	1991-93	-	-	-	18-1374	18-1378	18-4040	18-1352	-	-	-	-
70	1994-97	-	-	-	18-1374	-	-	18-1352	-	-	-	-
75	1960-65	-	-	-	-	18-1378	18-4040	18-1352	-	-	-	-
75	1975	-	-	-	-	18-1378	18-4040	18-1352	-	18-1372	18-1154	-
75	1976-84	-	-	18-4075	18-1374	18-1378	18-4040	18-1352	-	18-1372	18-1154	-
75	1982-88	-	-	18-4075	18-1374	18-1378	18-4040	18-1352	-	18-1372	18-1154	-
75	1985-88	-	-	-	18-1374	18-1378	18-4040	18-1352	-	18-1372	18-1154	-
75 ⑥	1976-88	-	-	18-4075	18-1374	18-1378	18-4040	18-1352	-	18-1372	18-1154	-
V-4 CROSSFLOW												
65JET	1992-95	-	-	18-4075	18-1374	18-1361	18-4040	18-1353	18-1377	-	18-1395	18-1386
80	1966- 67	-	-	-	-	18-1378	18-4040	18-1352	-	-	-	-
80JET	1993-97	-	-	18-4075	18-1374	18-1361	18-4040	18-1353	18-1377	-	18-1395	18-1386
80JET	1992-97	-	-	-	18-1374	18-1361	18-4040	18-1353	18-1377	-	18-1395	18-1386
85	1968-72	-	-	-	-	18-1378	18-4040	18-1352	-	-	18-1154	-
85	1973	-	-	-	18-1374	18-1378	18-4040	18-1352	-	-	18-1395	-
85	1974-78	-	-	-	18-1374	18-1361	18-4040	18-1352	-	-	18-1395	-
85 ⑥	1979-80	-	-	18-4075	18-1374	18-1361	18-4040	18-1353	18-1377	-	18-1395	18-1386
85 ⑥	1991-95	-	-	-	18-1374	18-1361	18-4040	18-1353	18-1377	-	18-1395	18-1386
85	1979-80,92	-	-	18-4075	18-1374	18-1361	18-4040	18-1353	18-1377	-	18-1395	18-1386
85TTL	1992-95	-	-	18-4075	18-1374	18-1361	18-4040	18-1353	18-1377	-	18-1395	18-1386
88	1987-91	-	-	18-4075	18-1374	18-1361	18-4040	18-1353	18-1377	-	18-1395	18-1386
88 ⑥	1987-96	-	-	18-4075	18-1374	18-1361	18-4040	18-1353	18-1377	-	18-1395	18-1386
88	1987-92	-	-	18-4075	18-1374	18-1361	18-4040	18-1353	18-1377	-	18-1395	18-1386
88	1993	-	-	18-4075	18-1374	18-1361	18-4040	18-1353	18-1377	-	18-1395	18-1386
88	1992-96	-	-	18-4075	18-1374	18-1361	18-4040	18-1353	18-1377	-	18-1395	18-1386
90	1981-86	-	-	18-4075	18-1374	18-1361	18-4040	18-1353	18-1377	-	18-1395	18-1386
90	1986-91	-	-	18-4075	18-1374	18-1361	18-4040	18-1353	18-1377	-	18-1395	18-1386
90	1992-94	-	-	18-4075	18-1374	18-1361	18-4040	18-1353	18-1377	-	18-1395	18-1386
90 ⑥ ④	1981-97	-	-	18-4075	18-1374	18-1361	18-4040	18-1353	18-1377	-	18-1395	18-1386
90 ④	1981-97	-	-	18-4075	18-1374	18-1361	18-4040	18-1353	18-1377	-	18-1395	18-1386
90 ⑤	1995-97	-	-	18-4075	18-1374	18-1361	18-4040	18-1353	18-1377	-	18-1395	18-1386
90JET ⑥	1994-95	-	-	18-4075	18-1374	18-1361	18-4040	18-1353	18-1377	-	18-1395	18-1386
90	1981-92	-	-	18-4075	18-1374	18-1361	18-4040	18-1353	18-1377	-	18-1395	18-1386
90	1993	-	-	18-4075	18-1374	18-1361	18-4040	18-1353	18-1377	-	18-1395	18-1386
100	1966- 68	-	-	-	-	18-1378	18-4040	18-1352	-	-	18-1154	-
100	1971- 72	-	-	-	-	18-1378	18-4040	18-1352	-	-	18-1154	-
100 ⑥	1979-80	-	-	18-4075	18-1374	18-1361	18-4040	18-1353	18-1377	-	18-1395	18-1386
100	1984-85	-	-	18-4075	18-1374	18-1361	18-4040	18-1353	18-1377	-	18-1395	18-1386
100	1986-91	-	-	18-4075	18-1374	18-1361	18-4040	18-1353	18-1377	-	18-1395	18-1386
100 ⑥	1990-94	-	-	18-4075	18-1374	18-1361	18-4040	18-1353	18-1377	-	18-1395	18-1386
100 Comm ⑥	1984-97	-	-	18-4075	18-1374	18-1361	18-4040	18-1353	18-1377	-	18-1395	18-1386
100	1979-81,92	-	-	18-4075	18-1374	18-1361	18-4040	18-1353	18-1377	-	18-1395	18-1386
100	1992-97	-	-	18-4075	18-1374	18-1361	18-4040	18-1353	18-1377	-	18-1395	18-1386

① Except "D" Models
② Two Cylinder Models

③ Three Cylinder Models
④ 90 Degree Models

⑤ 60 Degree Models
⑥ V-4, V-6 & V-8 Model engines do not include upper bearings in kits

APPLICATION CONTINUED ON NEXT PAGE

HP	Year	Sleeve	Connecting Rod	Rod Bolt	Wrist Pin Brg.	Rod Brg. Complete	Rod Brgs.	Center Main Brg.	Split Brg. (sleeve)	Upper Crank Brg.	Lower Crank Brg.	Powerhead Brg. Kit
100	1993	-	-	18-4075	18-1374	18-1361	18-4040	18-1353	18-1377	-	18-1395	18-1386
100 Comm	1984-87,89-92	-	-	18-4075	18-1374	18-1361	18-4040	18-1353	18-1377	-	18-1395	18-1386
100 Comm.	1993	-	-	18-4075	18-1374	18-1361	18-4040	18-1353	18-1377	-	18-1395	18-1386
110 ⑥	1986-89	-	-	18-4075	18-1374	18-1361	18-4040	18-1353	18-1377	-	18-1395	18-1386
112 ⑥	1994-96	-	-	-	18-1374	18-1361	18-4040	18-1353	18-1377	-	18-1395	18-1386
115	1969-70	-	-	-	-	18-1378	18-4040	18-1352	-	-	18-1154	-
115	1973	-	-	18-4075	18-1374	18-1378	18-4040	18-1352	-	-	18-1395	-
115	1974-78	-	-	18-4075	18-1374	18-1361	18-4040	18-1352	-	-	18-1395	-
115 ⑥ ④	1990-97	-	-	-	18-1374	18-1361	18-4040	18-1353	18-1377	-	18-1395	18-1386
115 ⑥	1979-85	-	-	18-4075	18-1374	18-1361	18-4040	18-1353	18-1377	-	18-1395	18-1386
115	1991-92	-	-	18-4075	18-1374	18-1361	18-4040	18-1353	18-1377	-	18-1395	18-1386
115	1990-91	-	-	18-4075	18-1374	18-1361	18-4040	18-1353	18-1377	-	18-1395	18-1386
115	1993	-	-	18-4075	18-1374	18-1361	18-4040	18-1353	18-1377	-	18-1395	18-1386
115	1992-94	-	-	18-4075	18-1374	18-1361	18-4040	18-1353	18-1377	-	18-1395	18-1386
115 ④	1990-97	-	-	-	18-1374	18-1361	18-4040	18-1353	18-1377	-	-	-
115 ⑤	1995-97	-	-	-	-	18-1361	18-4040	18-1353	18-1377	-	-	-
115JET ⑥	1994-97	-	-	-	18-1374	18-1361	18-4040	18-1353	18-1377	-	18-1395	18-1386
115C	1984	-	-	18-4075	18-1374	18-1361	18-4040	18-1353	18-1377	-	18-1395	18-1386
120 ⑥	1985-94	-	-	-	18-1376	18-1360	-	18-1353	18-1377	-	18-1396	-
125	1971-72	-	-	-	-	18-1378	18-4040	18-1352	-	-	-	-
125 Comm ⑥	1989-95	-	-	-	18-1376	18-1360	-	18-1353	18-1377	-	18-1396	-
125Esx ⑥	1991-94	-	-	-	18-1376	18-1360	-	18-1353	18-1377	-	18-1396	-
130 ⑥	1994-97	-	-	-	18-1376	18-1360	-	18-1353	18-1377	-	18-1396	-
135	1973	-	-	-	18-1374	18-1378	18-4040	18-1352	-	-	18-1395	-
135	1974-76	-	-	18-4075	18-1374	18-1361	18-4040	18-1352	-	-	18-1395	-
140	1977-78	-	-	18-4075	18-1374	18-1361	18-4040	18-1352	-	-	18-1395	-
140	1979	-	-	18-4075	-	-	-	-	-	-	-	-
140 ⑥	1979-84	-	-	-	18-1374	18-1361	18-4040	18-1353	18-1377	-	18-1395	18-1386
140 ⑥	1985-94	-	-	-	18-1376	18-1360	-	18-1353	18-1377	-	18-1396	-
140	1977-84	-	-	18-4075	18-1374	18-1361	18-4040	18-1353	18-1377	-	18-1395	18-1386
1600CC	1988	-	-	18-4075	-	-	-	-	-	-	-	-
1.6L	-	-	-	18-4075	-	-	-	-	-	-	-	-
V-6 CROSSFLOW												
150 ⑥	1978-91	-	-	-	18-1374	18-1361	18-4040	18-1353	18-1377	-	18-1395	-
150 ⑤	1991-97	-	-	-	-	18-1361	18-4040	18-1353	-	-	-	-
150 Comm ⑤	1993-95	-	-	-	-	18-1361	18-4040	18-1353	-	-	-	-
150	1978-85	-	-	18-4075	18-1374	18-1361	18-4040	18-1353	18-1377	-	18-1395	-
150	1978-88	-	-	18-4075	18-1374	18-1361	18-4040	18-1353	18-1377	-	18-1395	-
150	1986-91	-	-	18-4075	18-1374	18-1361	18-4040	18-1353	18-1377	-	-	-
150	1989-91	-	-	18-4075	18-1374	18-1361	18-4040	18-1353	18-1377	-	-	-
155 Comm	1984-85	-	-	18-4075	18-1374	18-1361	18-4040	18-1353	18-1377	-	18-1395	-
155 Comm ⑥	1984-92	-	-	-	18-1374	18-1361	18-4040	18-1353	18-1377	-	18-1395	-
155 Comm	1986-91	-	-	18-4075	-	-	-	-	-	-	-	-
175 ⑥	1977-91	-	-	-	18-1374	18-1361	18-4040	18-1353	18-1377	-	18-1395	-
175 ⑤	1991-97	-	-	-	-	18-1361	18-4040	18-1353	-	-	-	-
175	1977-83	-	-	18-4075	18-1374	18-1361	18-4040	18-1353	18-1377	-	-	-
175	1986-90	-	-	18-4075	18-1374	18-1361	18-4040	18-1353	18-1377	-	-	-
175	1977-83,85	-	-	18-4075	18-1374	18-1361	18-4040	18-1353	18-1377	-	-	-
185 ⑥	1984-85	-	-	18-4075	18-1374	18-1361	18-4040	18-1353	18-1377	-	18-1395	18-1389
185	1990	-	18-4148-1	18-4076	-	-	-	-	-	-	-	-
185 ⑥	1990-94	-	-	-	18-1376	18-1360	-	18-1353	18-1377	-	18-1396	18-1389
185	1990-93	-	18-4148-1	18-4076	-	-	-	-	-	-	-	-

① Except "D" Models
② Two Cylinder Models

③ Three Cylinder Models
④ 90 Degree Models

⑤ 60 Degree Models
⑥ V-4, V-6 & V-8 Model engines do not include upper bearings in kits

APPLICATION CONTINUED ON NEXT PAGE

HP	Year	Sleeve	Connecting Rod	Rod Bolt	Wrist Pin Brg.	Rod Brg. Complete	Rod Brgs.	Center Main Brg.	Split Brg. (sleeve)	Upper Crank Brg.	Lower Crank Brg.	Powerhead Brg. Kit
185	1992-94	-	18-4148-1	18-4076	-	-	-	-	-	-	-	-
200 ⑥	1976-83	-	-	18-4075	18-1374	18-1361	18-4040	18-1353	18-1377	-	18-1395	18-1389
200	1986-97	-	-	-	18-1376	18-1360	-	18-1353	18-1377	-	18-1396	-
200 Comm	1990	-	18-4148-1	18-4076	-	-	-	-	-	-	18-1396	-
200 Comm	1990-94	-	-	-	18-1376	18-1360	-	18-1353	18-1377	-	-	-
200	1976-83	-	-	18-4075	18-1374	18-1361	18-4040	18-1353	18-1377	-	18-1395	-
200C	1990	-	-	18-4076	18-1376	18-1360	-	18-1353	18-1377	-	18-1396	-
200	1986-91	-	-	18-4076	-	-	-	-	-	-	-	-
200	1986-93	-	-	18-4076	-	-	-	-	-	-	-	-
225 ⑥	1986-97	-	-	-	18-1376	18-1360	-	18-1353	18-1377	-	18-1396	18-1389
235 ⑥	1978-85	-	-	18-4075	18-1374	18-1361	18-4040	18-1353	18-1377	-	18-1395	-
235	1978-79	-	-	18-4075	18-1374	18-1361	18-4040	18-1353	18-1377	-	-	-
235	1980-85	18-4718	-	18-4075	18-1374	18-1361	18-4040	18-1353	18-1377	-	-	-
250	1991-95	-	-	-	18-1376	18-1360	-	18-1353	18-1377	-	18-1396	-
250	1997	-	-	-	18-1376	18-1360	-	18-1353	18-1377	-	18-1396	-
275	1985-88	-	-	-	18-1376	18-1360	-	18-1353	18-1377	-	18-1396	-
3.6L	1985-87	-	-	-	18-1376	18-1360	-	18-1353	18-1377	-	18-1396	-
300	1988-95	-	-	-	18-1376	18-1360	-	18-1353	18-1377	-	18-1396	-
2500CC	1988	-	-	-	-	-	-	-	-	-	-	-
2.5L	1982,84-85	-	-	-	-	-	-	-	-	-	-	-
2.6L	1982-86	18-4718	-	-	-	-	-	-	-	-	-	-

V-4 LOOPER												
120	1985	-	-	18-4076	18-1376	18-1360	-	18-1353	18-1377	-	18-1396	-
120	1985-94	-	-	18-4076	18-1376	18-1360	-	18-1353	18-1377	-	18-1396	-
125	1985-94	-	-	18-4076	18-1376	18-1360	-	18-1353	18-1377	-	18-1396	-
140	1985-94	-	-	18-4076	18-1376	18-1360	-	18-1353	18-1377	-	18-1396	-
1.8L	ALL	-	-	18-4076	-	-	-	-	-	-	-	-

V-6 LOOPER												
225	1986-91	-	-	18-4076	18-1376	18-1360	-	18-1353	18-1377	-	18-1396	-
225	1986-93	-	-	18-4076	18-1376	18-1360	-	18-1353	18-1377	-	18-1396	-
2.7L	1987	-	-	18-4076	-	-	-	-	-	-	-	-
275	1985-88	-	-	18-4076	18-1376	18-1360	-	18-1353	18-1377	-	18-1396	-
300	1985-95	-	-	18-4076	18-1376	18-1360	-	18-1353	18-1377	-	18-1396	-

- ① Except "D" Models
- ② Two Cylinder Models
- ③ Three Cylinder Models
- ④ 90 Degree Models
- ⑤ 60 Degree Models
- ⑥ V-4, V-6 & V-8 Model engines do not include upper bearings in kits



18-4329 CRANKSHAFT SEAL KIT
For: 20-35 HP

HP	Years	HP	Years
20	1981-89	30	1984-89
25	1977-89	35	1976-89
28	1986-88		



18-4330 CRANKSHAFT SEAL KIT
For: 40-75 HP

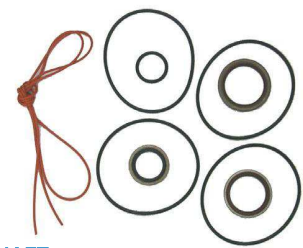

18-4331 CRANKSHAFT SEAL KIT
For: Crossflow V-4 - V-6



18-4332 CRANKSHAFT SEAL KIT
For: 9.9 - 15 HP



18-8355 CRANKSHAFT SEAL KIT
For:

Year	Model/HP	Year	Model/HP
1990	20-30AC, TE, E/ 20-35R/25COMM.	1993-96	20-35R/25/30TE/ 20-30E
1991-92	25/28/32R, TE, RE	1994-96	20-30AC, E/ 25COMM./28



18-1286 UPPER CRANKSHAFT SEAL
Replaces: 336232
For: 60° & EFI 90-115HP & 150-175HP



***18-7895**
OIL FILTER
Replaces: 778888, 5035703
200/225 (2004-05)



***18-7896**
OIL FILTER
Replaces: 778886, 5033539
90-115 EFI (2003-05)



***18-7897**
OIL FILTER
Replaces: 778887, 5033919
140 EFI (2003-05)



18-7903
OIL FILTER
Replaces: 5033102, 763364
9.9-15HP (2002-07)



***18-7915-1**
OIL FILTER
Replaces: 778885, 5031411
25-70 HP (1998-2005)



***18-7916**
OIL FILTER
Replaces: 434839
9.9 & 15 HP models from (1995-2001)
OMC Built



18-70936
HOSE (CYLINDER HEAD, STARBOARD)
Replaces: 340975, 321724
Fits: 90 (1994-95), 100 (1996-97), 115 (1994-97), E88 (1996), E90 (1996-98),
E100 (1996-97), E112 (1996), E115 (1996-98), J88 (1996), J90 (1996-98), J100
(1997-98), J112 (1996), J115 (1996-98)



18-70937
HOSE (CYLINDER HEAD, PORT)
Replaces: 340976
Fits: 90 (1994-95), 100 (1996-97), 115 (1994-97), E88 (1996), E90 (1996-98),
E100 (1996-97), E112 (1996), E115 (1996-98), J88 (1996), J90 (1996-98), J100
(1997-98), J112 (1996), J115 (1996-98)

SSEE PAGES 201-202 FOR OUR COMPLETE LINE OF GASKET SEALANTS

— CONTAINS —

Part #	Desc.	O.E. #	Qty.
18-0933	Air Silencer Gasket	314115	1
18-0935	Base To Cover Gasket	314322	1
18-0951	Carburetor to Manifold Gasket	317305	1
18-2543	Water Jacket Gasket	318609	1
18-0118	Carburetor Gasket	325092	3
18-2913	Exhaust Cover Gasket	318609	2
18-2938	Exhaust Cover Gasket	331917	1
18-2548	Thermostat Gasket	332108	1
18-2865	Adapter to Powerhead Gasket	313763	1
18-0929	Thermostat Gasket	313416	1



18-4300
POWERHEAD GASKET SET
Replaces: 385416, 439084

— CONTAINS —

Part #	Desc.	O.E. #	Qty.
18-2876	By-Pass Cover Gasket	307133	4
18-2866	Exhaust Cover Gasket	317914	2
18-0953	Water Pass. Gasket	317951	1
18-0117	Exhaust Plate Gasket	317995	1
18-0955	Exhaust Cover Gasket	318156	1
18-2873	Cyl. Cover Starboard Gasket	318335	2
18-0957	Adapter To Powerhead Gasket	318373	1
18-2867	Manifold to Crankcase Gasket	319174	1
18-2864	Adapter to Powerhead Gasket	321727	1
18-0991	Leaf Plate Gasket	321907	4
18-0134	Carburetor to Manifold Gasket	327707	2
18-2857	Air Silencer To Carburetor Gasket	386573, 319771	2

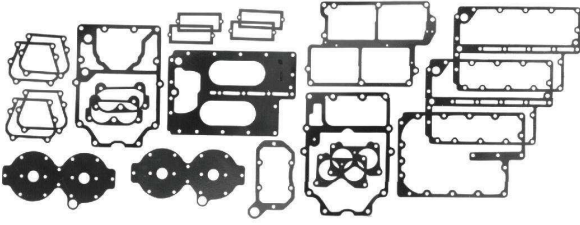

18-4301
POWERHEAD GASKET SET
Replaces: 388602

APPLICATIONS BEGIN ON PAGE 308

* Anti-Drain-Back Valve
Valve eliminates dry starts, prevents oil from draining back into crankcase during engine shutdown.

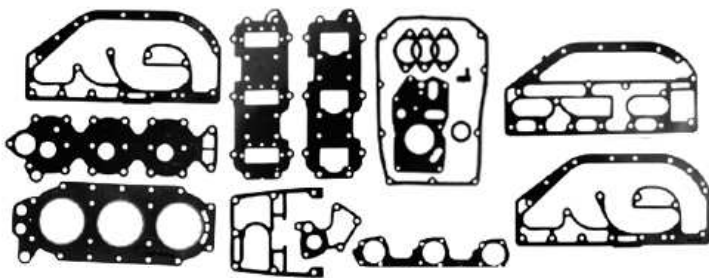

18-4302
POWERHEAD GASKET SET
Replaces: 390078

— CONTAINS —			
Part #	Desc.	O.E. #	Qty.
18-2960	Head Gasket	313413	1
18-2865	Adapter to Powerhead Gasket	313763	1
18-0951	Carb to Manifold Gasket	317305	1
18-2543	Water Jacket Gasket	318609	1
18-0989	Air Silencer Gasket	321794	1
18-0118	Carburetor Gasket	325092	3
18-0102	Exhaust Manifold Gasket	323469	1
18-2913	Exhaust Cover Gasket	331916	2
18-2938	Exhaust Cover Gasket	331917	1
18-2548	Thermostat Cover Gasket	332108	1
18-0975	Carb to Silencer Gasket	333008	1

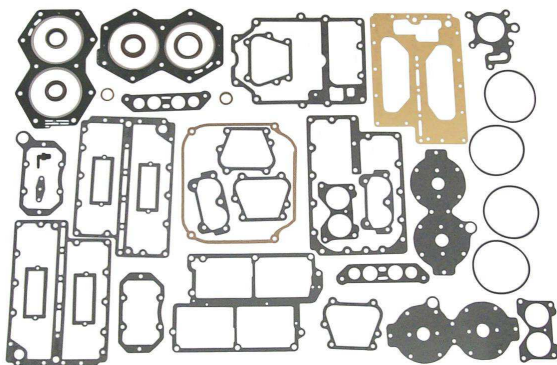

18-4303-1
POWERHEAD GASKET SET
Replaces: 389556, 391300, 439085

— CONTAINS —			
Part #	Desc.	O.E. #	Qty.
18-0850	Fuel Pump Mtg Gasket	303615	1
18-2876	By-Pass Cover Gasket	307133	4
18-2866	Exhaust Cover Gasket	317914	2
18-0953	Water Passage Gasket	317951	1
18-0117	Exhaust Plate Gasket	317995	1
18-2873	Gasket	318335	2
18-2074	Seal	0339620	1
18-2956	Water Jacket Head Gasket	318358	2
18-2867	Manifold to Crankcase Gasket	319174	1
18-2857	Air Silencer to Carb. Gasket	386573, 319771	2
18-0985	Air Silencer Gasket	321722	1
18-2864	Adapter to Powerhead Gasket	321727	1
18-0991	Leaf Plate Gasket	321907	4
18-2547	Water Pass. Cover Gasket	322858	1
18-0102	Exhaust Manifold Gasket	323469	1
18-0134	Intake Plate Gasket	326926	1
18-0977	Thermostat Gasket	332369	2

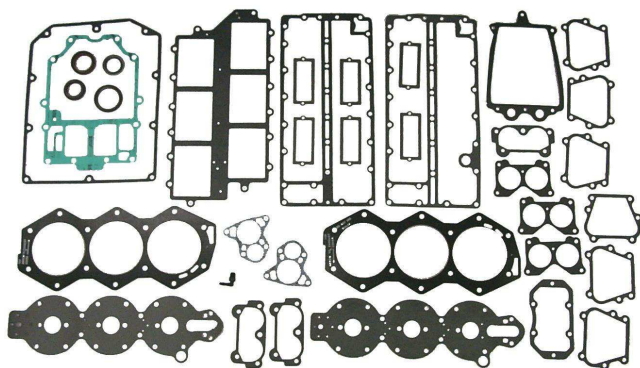

18-4304-1
POWERHEAD GASKET SET
Replaces: 391988

— CONTAINS —			
Part #	Desc.	O.E. #	Qty.
18-2549	Exhaust Plate Gasket	321543	1
18-2876	By-Pass Cover Gasket	307133	6
18-2544	Water Jacket Cover Gasket	321028	2
18-2545	Exhaust Plate Gasket	321182	1
18-0979	Air Silencer Gasket	321183	1
18-2546	Thermostat Gasket	321184	2
18-0991	Leaf Plate Gasket	321907	6
18-2547	Water Passage Cover Gasket	322858	1
18-0995	Adapter to Powerhead Gasket	323222	1
18-0134	Carburetor To Manifold Gasket	327707	3
18-0148	Intake Manifold Gasket	329718	1
18-2964	Head Gasket	320745, 335360, 766779	2
18-2550	Powerhead Gasket	323214	1
18-2857	Air Silencer To Carburetor Gasket	386573, 319771	1
18-2001	Oil Seal	330137	1
18-2074	Oil Seal	0339620	2
18-8307	Oil Seal	331103	1

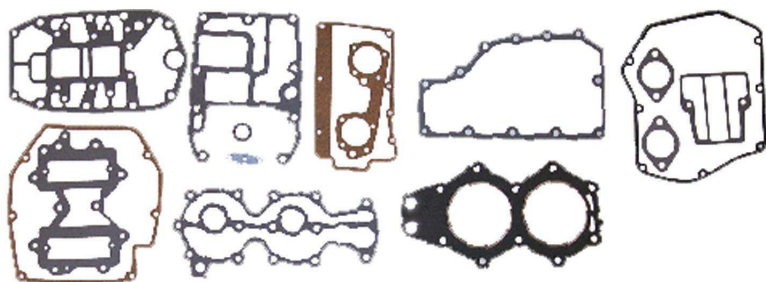

18-4305
POWERHEAD GASKET SET
Replaces: 393433, 437806, 439083
For: 2 cylinder models only

— CONTAINS —			
Part #	Desc.	O.E. #	Qty.
18-0851	Relief Port Twin Gasket	329826	1
18-0850	Fuel Pump Mtg. Gasket	303615	1
18-0941	Water Jacket Cover Gasket	315538	1
18-0118	Carburetor Gasket	325092	2
18-0120	Exhaust Cover Gasket	325211	1
18-0128	Powerhead Mtg. Twin Gasket	326468, 351018	1
18-3802	Head Gasket	327795, 335359	1
18-0136	Powerhead Mounting Gasket	328283	1
18-0157	Airbox Split Twin Gasket	330698	1
18-0154	Airbox Split Twin Gasket	—	1
18-0159	Airbox Split Twin Gasket	330909	1
18-0983	Carb. to Air Box Twin Gasket	321497	1
18-0182	Thermostat Gasket	310058	1
18-0963	Intake Manifold Twin Gasket	335633	1

— CONTAINS —

Part #	Desc.	O.E. #	Qty.
18-0850	Fuel Pump Mtg. Gasket	303615	1
18-0122	Outer Leaf Plate Gasket	325260	1
18-0961	Carburetor to Intake Manifold Gasket	318932	1
18-0967	By-Pass Cover Gasket	319332	1
18-0112	Powerhead Mtg. Gasket	324717	1
18-0959	Inner Leaf Plate Gasket	318924	1
18-2907	Adapter Housing Gasket	325721	1
18-2905	Water Cover Gasket	329920	1
18-2853	Exhaust Cover Gasket	318925	2
18-2963	Head Gasket	330818	1
18-2879	Filter Cap to Pump Gasket	331363, 338876	1

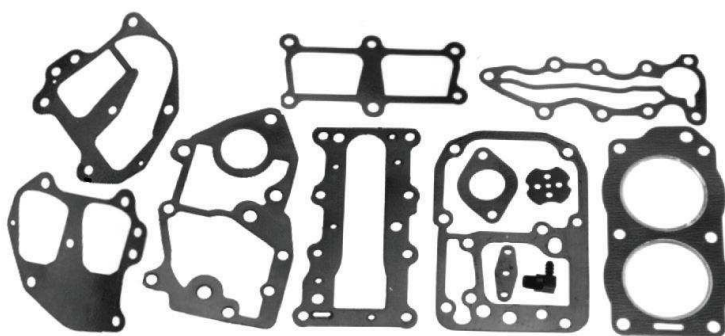

18-4306
POWERHEAD GASKET SET
Replaces: 394546

— CONTAINS —

Part #	Desc.	O.E. #	Qty.
18-0850	Fuel Pump Mounting Gasket	303615	1
18-0971	By-Pass Gasket	319661	1
18-0981	Leaf Plate Gasket	321479	1
18-0106	Exhaust Manifold Gasket	324323	2
18-0118	Carburetor Gasket	325092	1
18-2862	Manifold to Leaf Plate Gasket	321573, 326260	1
18-0126	Inner Exhaust Cover Gasket	326264	1
18-2852	Powerhead to Lower Unit Gasket	330621	1
18-3803	Head Gasket	329419, 765012	1

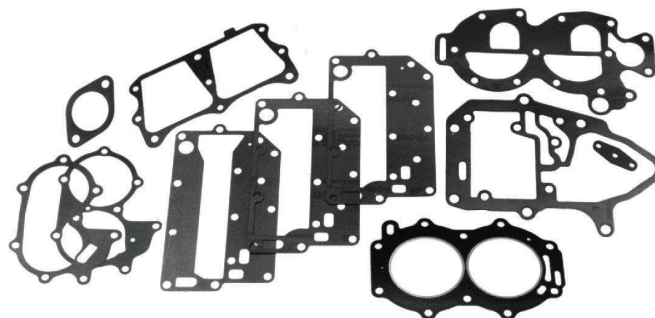

18-4307
POWERHEAD GASKET SET
Replaces: 433941, 392567, 392615, 389206

— CONTAINS —

Part #	Desc.	O.E. #	Qty.
18-0991	Leaf Plate	321907	6
18-0995	Adapter to Powerhead Gasket	323222	1
18-0134	Carburetor to Manifold Gasket	327707	3
18-0148	Intake Manifold Gasket	329718	1
18-0979	Air Silencer Gasket	321183	1
18-0945	Outer Exhaust Gasket	336430	1
18-0927	Inner Exhaust Cover Gasket	393561	1
18-2544	Water Jack. Cover Gasket	321028	2
18-2546	Thermostat Gasket	321184	2
18-2547	Water Passage Cover Gasket	322858	1
18-2550	Powerhead Gasket	323214	1
18-2857	Air Silencer Carburetor Gasket	386573, 319771	1
18-2876	By-Pass Cover Gasket	307133	6
18-7416	O-Ring	329380	1
18-7417	O-Ring	329381	1
18-3801	Head Gasket	325647, 335361	2

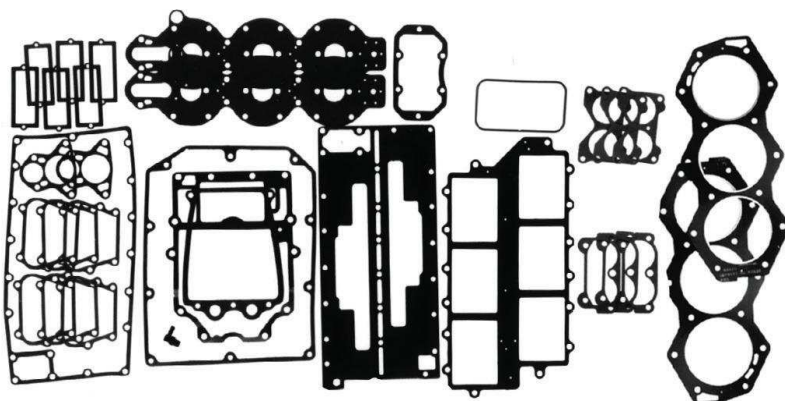

18-4309
POWERHEAD GASKET SET
Replaces: 394885, 434381

— CONTAINS —

Part #	Desc.	O.E. #	Qty.
18-0142	Intake Manifold Gasket	328622	1
18-0155	Rectifier Mtg. Gasket	330412	2
18-0138	Adapter to Powerhead Gasket	328590	1
18-0140	AirBox Gasket	328604	2
18-2074	Oil Seal	0339620	1
18-2075	Oil Seal	0353076	1
18-7418	O-Ring	326741	4
18-3837	Head Gasket	328623	2
18-0978	Cover to Base Gasket	331598	2

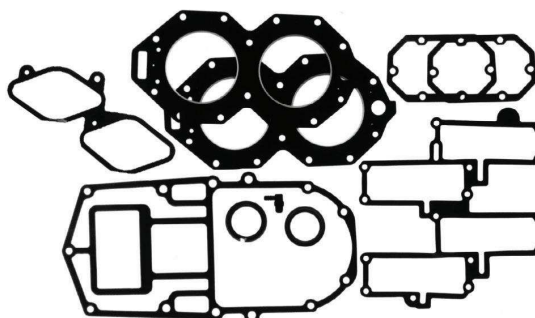

18-4310
POWERHEAD GASKET SET
Replaces: 396750

APPLICATION BEGINS ON PAGE 308

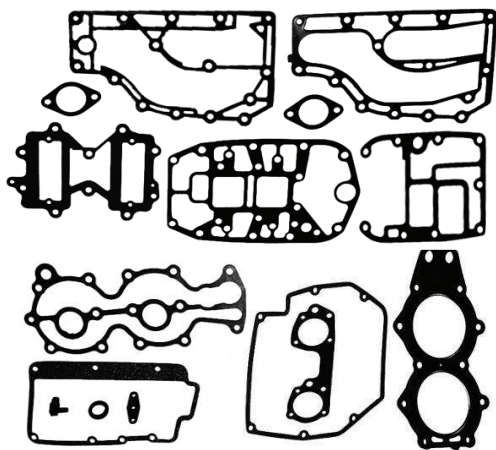

18-4318
POWERHEAD GASKET SET
 Replaces: 390076

— CONTAINS —

Part #	Desc.	O.E. #	Qty.
18-0963	Intake Manifold GasketTwin	335633	1
18-0850	Fuel Pump Mtg. Gasket	303615	1
18-0118	Carburetor Gasket	325092	2
18-0983	Carburetor to Airbox	321497	1
18-3802	Head Gasket	327795, 335359	1
18-0941	Water Jacket Cover Gasket	315538	1
18-0157	Air Box Split Gasket	330698	1
18-0128	Powerhead Mounting Gasket	326468, 351018	1
18-0136	Powerhead Mounting Gasket	328283	1
18-1224	Exhaust Cover Gasket	315869	1
18-1218	Exhaust Cover Gasket	315868	1
18-0182	Seal	310058	1

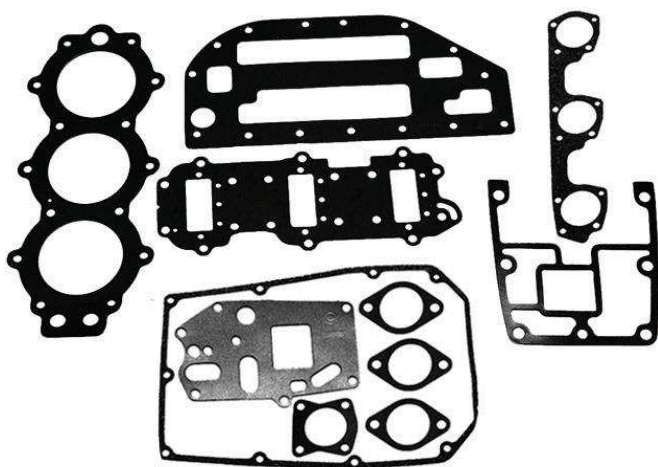

18-4321
POWERHEAD GASKET SET
 Replaces: 398047, 438904

— CONTAINS —

Part #	Desc.	O.E. #	Qty.
18-0118	Carburetor Gasket	325092	3
18-0989	Air Silencer Gasket	321794	1
18-0975	Carb to Silencer Gasket	333008	1
18-3836	Head Gasket	329836	1
18-1202	Thermostat Cover Gasket	329830	1
18-1205	Adapter Gasket	329828	1
18-1207	Exhaust Manifold Gasket	329833, 343863	1
18-1212	Intake Manifold Gasket	326926	1
18-1219	Grommet	320880	1
18-1221	Retainer	330273	1

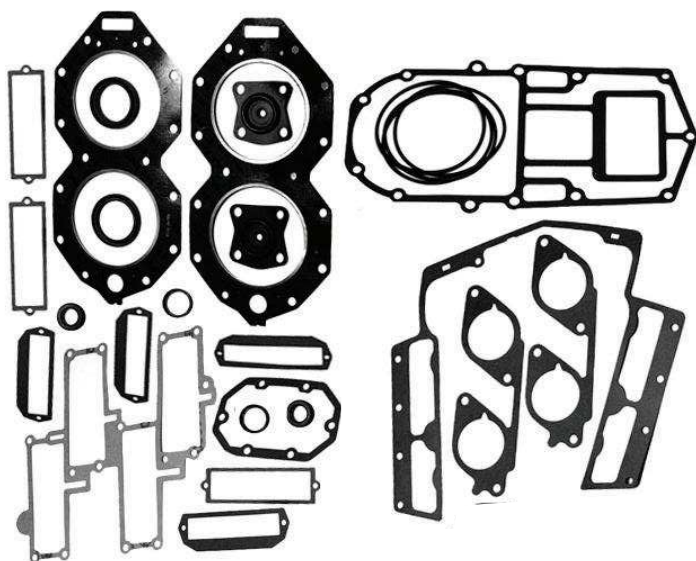

18-4322
POWERHEAD GASKET SET
 Replaces: 432570

— CONTAINS —

Part #	Desc.	O.E. #	Qty.
18-0987	Throttle Body to Manifold Gasket	332319	2
18-0142	Intake Manifold Gasket	328622	1
18-2074	Seal	0339620	1
18-2075	Seal	0353076	1
18-0130	Reed Box Gasket	332266	4
18-7418	O-Ring	326741	4
18-0155	Rectifier Mtg. Gasket	330412	1
18-3866	Head Gasket	328623, 340115	2
18-0138	Adapter to Powerhead Gasket	328590	1
18-0144	Reed Box Gasket	328626	4
18-1221	Retainer	330273	2
18-1219	Grommet	320880	2
18-1222	Thermostat Gasket	394408	2

— CONTAINS —

Part #	Desc.	O.E. #	Qty.
18-0130	Reed Box Gasket	332266	6
18-3839	Head Gasket	334726, 333670	2
18-0161	Lower Manifold Gasket	331532	1
18-0155	Rectifier Mtg. Gasket	330412	1
18-0142	Intake Manifold Gasket	328622	1
18-0987	Throttle Body to Manifold Gasket	332319	3
18-0978	Cover to Base Gasket	331598	1
18-0965	Adapter to Powerhead Gasket	333879	1
18-7418	O-Ring	326741	4
18-2074	Seal	0339620	1
18-2075	Seal	0353076	2
18-1222	Thermostat Gasket	394408	2
18-1221	Retainer	330273	2
18-1219	Grommet	320880	2
18-0412	Thermostat Gasket	337068	2

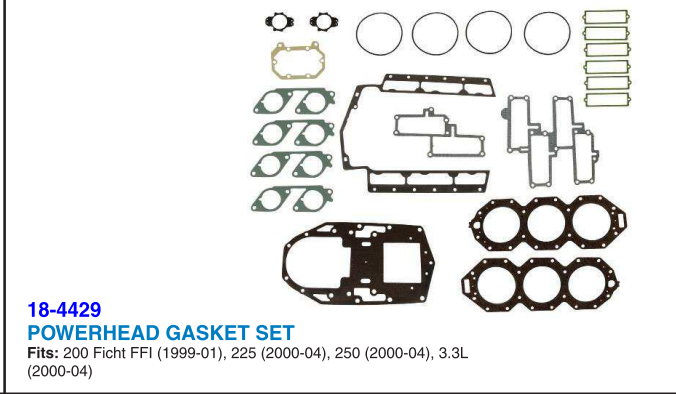
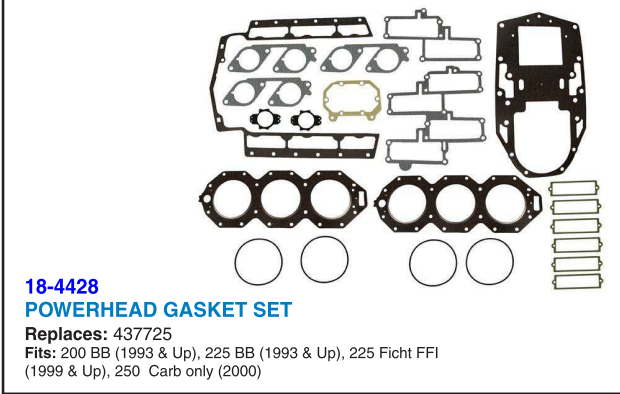
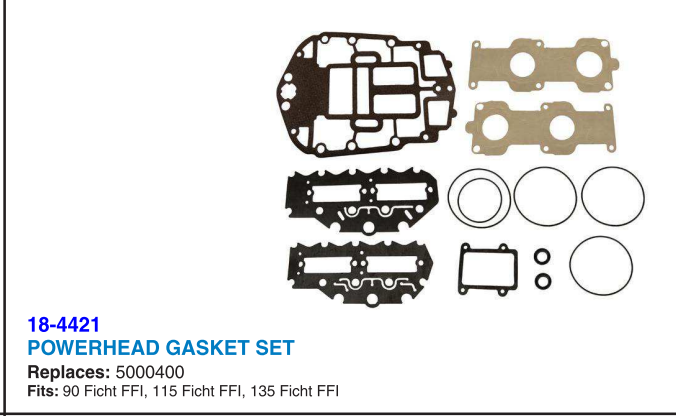
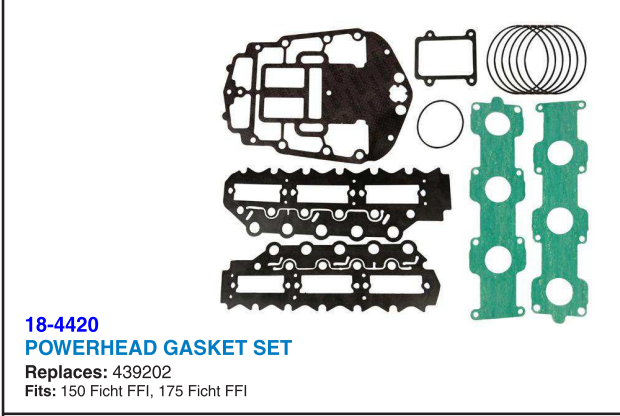
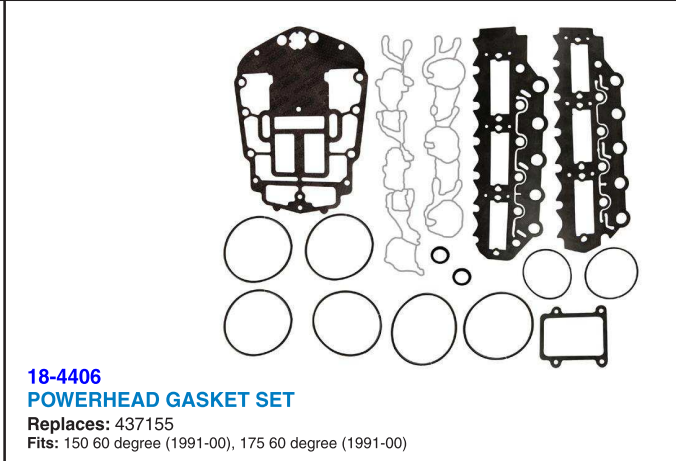
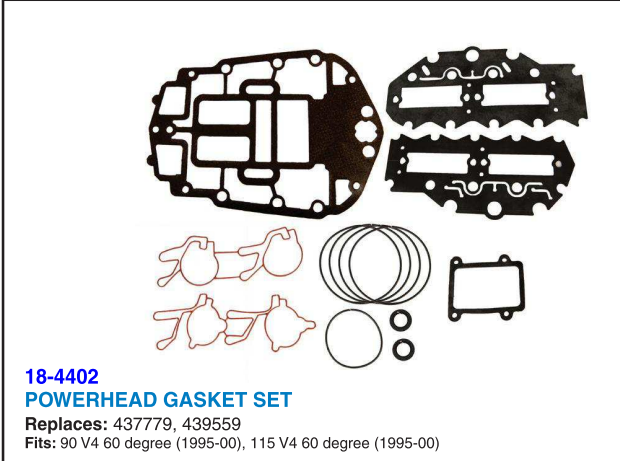
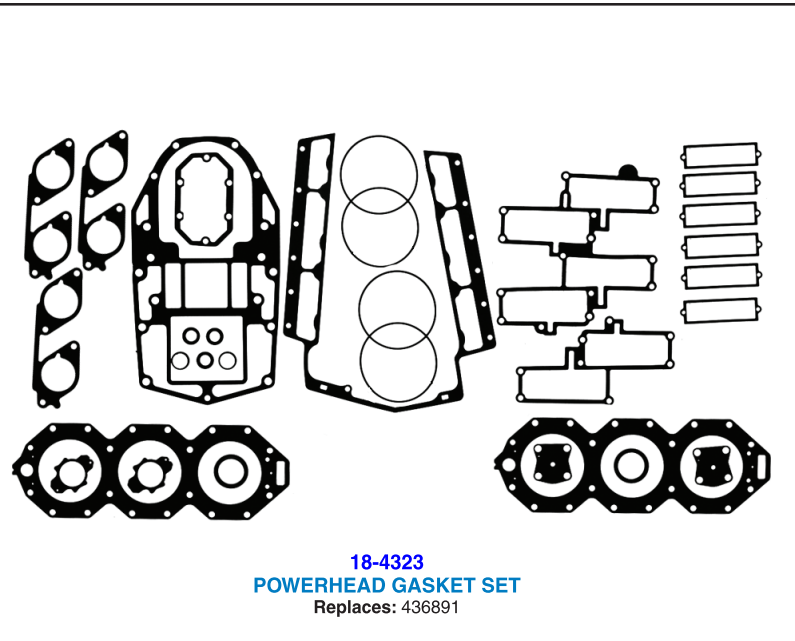

PKG. OF 2



18-2884
18-2884-9^①
HEAD GASKET
 Replaces: 313782

PKG. OF 2



18-2885
18-2885-9^①
HEAD GASKET
 Replaces: 303438

PKG. OF 2



18-2888
18-2888-9^①
HEAD GASKET
 Replaces: 332010, 326953



18-2950
HEAD GASKET
 Replaces: 309612, 766870

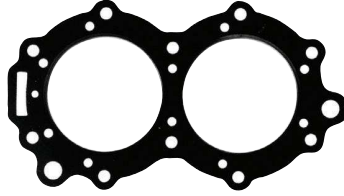

18-2951
HEAD GASKET
 Replaces: 304720



18-2952
HEAD GASKET
 Replaces: 203034

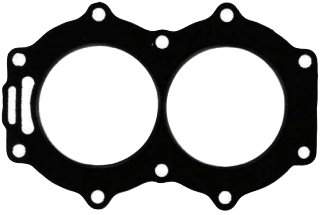

18-2954
HEAD GASKET
 Replaces: 319633



18-2956
HEAD GASKET
 Replaces: 318358



18-2957
HEAD GASKET
 Replaces: 307069



18-2958
HEAD GASKET
 Replaces: 315539



18-2959
HEAD GASKET
 Replaces: 306048

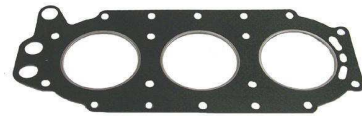

18-2960
HEAD GASKET
 Replaces: 313413



18-2961
HEAD GASKET
 Replaces: 329103

















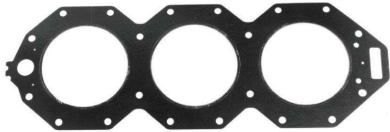

18-2962
HEAD GASKET
 Replaces: 322332

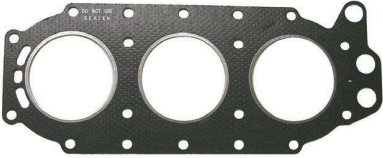

18-2963
HEAD GASKET
 Replaces: 330818, 320533, 318914

^① Priced per Package

 <p>18-2964 HEAD GASKET Replaces: 320745, 335360, 766779</p>	 <p>18-3800 HEAD GASKET Replaces: 325273</p>	 <p>18-3801 HEAD GASKET Replaces: 325647, 335361</p>
 <p>18-3802 HEAD GASKET Replaces: 320658, 327795, 335359</p>	 <p>18-3803 HEAD GASKET Replaces: 324324, 329419, 765012 For: 2 cylinder models only</p>	 <p>18-3836 HEAD GASKET Replaces: 329836</p>
 <p>18-3837 HEAD GASKET Replaces: 328623</p>	 <p>18-3838 HEAD GASKET Replaces: 331211</p>	 <p>18-3839 HEAD GASKET Replaces: 333670, 334726</p>
 <p>18-3841-2 HEAD GASKET Replaces: 203130</p>	 <p>18-3898 HEAD GASKET Replaces: 332819</p>	 <p>18-3866 HEAD GASKET Replaces: 340115, 333549 For: V-4 Loop Charge</p>
 <p>18-3895 HEAD GASKET Replaces: 332816</p>	 <p>18-3896 HEAD GASKET Replaces: 332817</p>	 <p>18-0491 HEAD GASKET Replaces: 346007 Fits: 200 Ficht FFI (1999-01), 225 (2000-04), 250 (2000-04), 3.3L (2000-04)</p>
 <p>18-0492 HEAD GASKET Replaces: 340919, 345257 Fits: 200 BB (1993 & Up), 225 BB (1993 & Up), 225 Ficht FFI (1999 & Up) 250 Carb only (2000)</p>	<p>PKG. OF 12</p> <p>18-7110 18-7110-9^① CYLINDER HEAD O-RING Replaces: 335523 3.960 O.D. x 0.103 H Fits: 90/115 HP (1995-98), 100 HP (1998), 105 HP (1997-98), 150/175 HP (1991-97) 90 Ficht FFI, 115 Ficht FFI, 135 Ficht FFI, 150 Ficht FFI, 175 Ficht FFI, 90 V4 60 degree(1995-00), 115 V4 60 degree (1995-00), 150 60 degree(1991-00), 175 60 degree(1991-00)</p>	

① Priced per Package

HEAD GASKET/GASKET SET APPLICATION

HP	Year	Head Gasket	Low Comp. Head Gasket	Gasket Set	HP	Year	Head Gasket	Low Comp. Head Gasket	Gasket Set
1.5	1968-70	18-2884	—	—	65 Comm.	1987-95	18-3836	—	18-4321
2, Colt, Jr.	1971-90	18-2884	—	—	65 Jet	1991-95	18-2956 ①	18-3898 ①	18-4303-1
2.5,3,4,4.5, Ultra, Excel 4	1981-93	18-2888	—	—	70	1974-76	18-2960	18-3895	18-4300 ⑨
3	1957-68	18-3841-2	—	—	70	1977-85	18-2960	18-3895	18-4302
4	1969-80	18-3841-2	—	—	75	1986-97	18-3836	—	18-4321
4.5	1980	18-3841-2	—	—	75	1960-65	18-2959 ①	—	—
5	1965-68	18-2961	—	—	75	1975	18-2960	18-3895	18-4300 ⑨
5	1984-95	18-3800	—	—	75	1977-88	18-2960	18-3895	18-4302
5.5	1957-58	18-2885	—	—	80	1966-67	18-2959 ①	—	—
5.5	1959-64	18-2961	—	—	80 Jet	1991-96	18-2956 ①	18-2956 ①	18-4303-1
6	1965-79	18-2961	—	—	85	1968-72	18-2959 ①	—	—
6	1984-95	18-3800	—	—	85	1979-80,91-95	18-2956 ①	18-3898 ①	18-4303-1
6.5 Comm.	1989-90	18-3800	—	—	88	1987-95	18-2956 ①	18-3898 ①	18-4303-1
7.5	1957-58	18-2952	—	—	90	1964-65	18-2959 ①	—	—
7.5	1980-93	18-3800	—	—	90	1981-95	18-2956 ①	18-3898 ①	18-4303-1
8	1984-95	18-3800	—	—	100	1966-72	18-2959 ①	—	—
9.5	1964-73	18-2950	—	—	100 ③	1979-95	18-2956 ①	18-3898 ①	18-4303-1
9.9	1974-92	18-2963	—	18-4306 ②	1600CC	1988	18-2956 ①	18-3898 ①	18-4303-1
10 Comm.	1989-90	18-2963	—	18-4306	110	1986-89	18-2956 ①	18-3898 ①	18-4303-1
14	1988-90	18-2963	—	18-4306	115	1969-70	18-2959 ①	—	—
15	1974-92	18-2963	—	18-4306 ④	115	1973-77	18-2956 ①	18-3898 ①	—
18	1959-73	18-2962	—	—	115	1978-95	18-2956 ①	18-3898 ①	18-4303-1
18 Jet	1995-98	18-3803	—	18-4307	120	1985-87	18-3837 ①	—	18-4310
20	1981-99	18-3803	—	18-4307	120	1988-94	18-3866 ①	—	18-4322
25	1969-76	18-2962	—	—	125 Comm.	1992-95	18-3866 ①	—	18-4322
25	1977-78	18-2954	—	—	130	1995-98	18-3866 ①	—	18-4322
25 ⑤	1979-03	18-3803	—	18-4307	135	1973-76	18-2956 ①	18-3898 ①	18-4301
28	1986-96	18-3803	—	18-4307	140	1977	18-2956 ①	18-3898 ①	18-4301
30 ⑤	1984-03	18-3803	—	18-4307	140	1978-84	18-2956 ①	18-3898 ①	18-4303-1
33	1965-70	18-2951	—	—	140	1985-87	18-3837 ①	—	18-4310
35	1957-58	18-2951	—	—	140	1988-94	18-3866 ①	—	18-4322
35	1976-78	18-2954	—	—	150	1973-91	18-2964 ①	18-3896 ①	18-4304-1
35	1979-88	18-3803	—	18-4307	155 Comm.	1984-92	18-2964 ①	18-3896 ①	18-4304-1
35 ⑥	1987	18-3802	—	18-4305	2500CC	1988	18-2964 ①	18-3896 ①	18-4304-1
40	1960-80	18-2957	—	—	175	1977-83	18-2964 ①	18-3896 ①	18-4304-1
40 Comm.	1981-90	18-2957	—	18-4324	175	1986-91	18-3801 ①	18-3897 ①	18-4309
40	1984-97	18-3802	—	18-4305	185	1984-85	18-2964 ①	18-3896 ①	18-4304-1
40 Comm.	1994-97	18-3802	—	18-4305	185	1990-93	18-3839 ①	—	18-4323
45 Comm.	1985-97	18-3802	—	18-4305	200	1976-83	18-2964 ①	18-3896 ①	18-4304-1
45SS	1987-90	18-3802	—	—	200	1986-87	18-3838 ①	—	—
48	1987-97	18-3802	—	18-4305	200 ③	1988-93	18-3839 ①	—	18-4323
50	1958-59	—	—	—	225	1986-87	18-3838 ①	—	—
50	1971-75	18-2958	—	18-4305 ⑦	225	1988-93	18-3839 ①	—	18-4323
50	1979-80	18-3802	—	18-4318	235	1978-79	18-2964 ①	18-3896 ①	—
50	1981-97	18-3802	—	18-4305	235	1980-85	18-3801 ①	18-3897 ①	18-4309
55	1968-69	18-2960	18-3895	—	275/3.6L	1985-87	18-3840 ①	—	—
55	1977-79	18-3802	—	18-4318	OMC SEA DRIVE				
55	1980-97	18-3802	—	18-4305	HP	Year	Head Gasket	Low Comp. Head Gasket	Gasket Set
55	1995	18-3802	—	—	1.6L	1983-90	18-2956	18-3898 ①	18-4303-1
60	1970-71	18-2960	18-3895	—	1.8L	1987	18-3837	-	-
60	1980-85	18-3802	—	18-4305	2.0L	1988-90	18-3866 ①	-	18-4322
60	1986-88	18-2960	18-3895	18-4302	2.5L	1982,84-85	18-2964	18-3896 ①	18-4304-1
60	1989-97	18-3836	—	18-4321	2.6L	1982-86	18-3801 ①	18-3897 ①	-
SST60	1989-90	18-3836	—	—	2.7L	1987	18-3838	-	-
65	1968	—	—	—	3.0L	1988-90	18-3839	-	-
65	1972-73	18-2960	18-3895	18-4300 ⑨	3.6L	1987	18-3840	-	-
65 Comm.	1984-86	18-2960	—	18-4302					

① Two head gaskets required per engine

② 1976 G & H Suffix models only

③ Commercial models also

④ 1976 A Suffix models only







⑤ For 2 cylinder models only

⑥ D Suffix models only

⑦ 18-2958 Head Gasket required to complete set

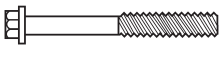
⑨ Head Gasket Not Available in Gasket Set

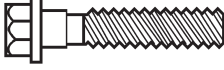

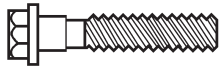
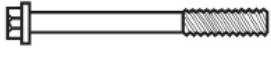





















STAINLESS STEEL BOLTS

		HEAD STYLES			
		HEX WASHER	HEX	PAN	FILLISTER
 18-3133 Replaces: 331979 1/4" x 20 x 1 1/16" HEX For: Rewind starters, water pump housings, mid-sections and jet drive units	 PKG. OF 2 18-3135 18-3135-9 ① Replaces: 306643 1/8" x 20 x 1/2" PAN HEAD For: Lower unit anodes, ignition covers and water pump housings	 PKG. OF 2 18-3136 18-3136-9 ① Replaces: 323626 1/4" x 20 x 1 3/4" HEX WASHER For: Water pump housings, exhaust covers, intake manifolds, ignition coils and more	 18-3153 Replaces: 908158 1/4" x 20 x 1/2" HEX For: Lower unit anodes, bearing carriers, 45 HP and up and Cobra, 5 HP lower engine covers		
 18-3365 Replaces: 909533 1/4" x 20 x 1" HEX WASHER For: Flywheel covers, intake covers and more	 18-3369 Replaces: 302325 1/8" x 20 x 1" HEX For: Impeller housings, ignition coils, exhaust covers, shift covers and starter brackets	 PKG. OF 5 18-4276 18-4276-9 ① Replaces: 324334 1/4" x 20 x 1 1/32" HEX WASHER For: Water pump housings, exhaust covers, intake manifolds, ignition coils and more	 PKG. OF 5 18-4277 Replaces: 324430 1/4" x 20 x 2" HEX For: Water pump housings, exhaust covers, intake manifolds, ignition coils and more		

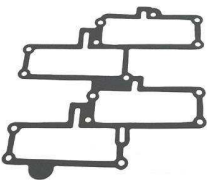
SEE PAGES 201-202 FOR OUR COMPLETE LINE OF GASKET SEALANTS

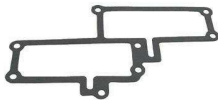











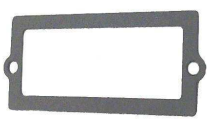



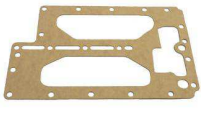

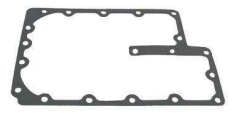
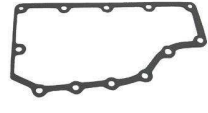
 PKG. OF 2 18-0118 18-0118-9 ① CARB GASKET Replaces: 325092	 PKG. OF 2 18-0134 18-0134-9 ① V-4 & V-6 CARB TO MANIFOLD GASKET Replaces: 327707	 PKG. OF 2 18-0961 18-0961-9 ① CARB MOUNTING GASKET Replaces: 318932	 18-0437 COVER GASKET Replaces: 334353	 18-0628 COVER GASKET Replaces: 341501
 18-1241 FLOAT BOWL AND NOZZLE GASKET	 18-2579 FLOAT BOWL GASKET Replaces: 338882	 18-2582 CARB BOWL GASKET Replaces: 338813	 18-8352 CARBURETOR MOUNTING GASKET Replaces: 332253	 PKG. OF 2 18-2890 18-2890-9 ① FLOAT BOWL GASKET Replaces: 331203, 338886, 302994
 PKG. OF 2 18-2893 18-2893-9 ① FLOAT BOWL GASKET Replaces: 303750	 PKG. OF 2 18-2903 18-2903-9 ① FLOAT BOWL GASKET Replaces: 332696, 338880	 PKG. OF 2 18-2906 18-2906-9 ① FLOAT BOWL GASKET Replaces: 333418, 333884, 338884 V-4, V-6	 PKG. OF 2 18-2908 18-2908-9 ① FLOAT BOWL GASKET Replaces: 331499, 338878	 PKG. OF 2 18-0850 18-0850-9 ① FUEL PUMP GASKET Replaces: 303615

① Priced per package

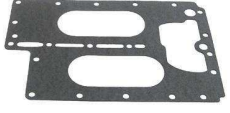
<p>PKG. OF 2</p>  <p>18-2879 18-2879-9① FILTER CAP TO PUMP GASKET Replaces: 331363, 338876, 312634</p>	<p>PKG. OF 2</p>  <p>18-2900 18-2900-9① CAP TO FUEL PUMP GASKET Replaces: 332694, 338879, 312679</p>	<p>PKG. OF 2</p>  <p>18-2889 18-2889-9① FILTER BOWL GASKET Replaces: 302675</p>	<p>PKG. OF 2</p>  <p>18-2892 18-2892-9① FILTER BOWL GASKET Replaces: 303355</p>	 <p>18-0140 AIR BOX GASKET Replaces: 328604</p>
 <p>18-0157 AIR BOX GASKET Replaces: 330698</p>	 <p>18-0159 AIR BOX GASKET Replaces: 330909</p>	 <p>18-0933 AIR SILENCER GASKET Replaces: 314115 70/75 HP</p>	 <p>18-0935 BASE TO COVER GASKET Replaces: 314322 70/75 HP</p>	<p>PKG. OF 2</p>  <p>18-0975 18-0975-9① CARB TO SILENCER GASKET Replaces: 333008 3 Cyl.</p>
 <p>18-0978 COVER TO BASE GASKET Replaces: 331598 For: 185, 200 & 225 H.P., V-6</p>	 <p>18-0979 AIR SILENCER GASKET Replaces: 321183 V-6</p>	<p>PKG. OF 2</p>  <p>18-0983 18-0983-9① CARB TO AIR BOX TWIN GASKET Replaces: 321497</p>	 <p>18-0985 AIR SILENCER GASKET Replaces: 321722 V-4</p>	 <p>18-0989 AIR SILENCER GASKET Replaces: 321794 3 Cyl.</p>
<p>PKG. OF 2</p>  <p>18-2857 18-2857-9① AIR SILENCER GASKET Replaces: 386573, 319771</p>	<p>PKG. OF 2</p>  <p>18-0122 18-0122-9① 9.9 & 15 HP OUTER LEAFPLATE GASKET Replaces: 325260</p>	<p>PKG. OF 2</p>  <p>18-0130 18-0130-9① REED BLOCK GASKET Replaces: 332266 For: V-4, V-6 & V-8</p>	 <p>18-0142 INTAKE MANIFOLD GASKET Replaces: 328622</p>	<p>PKG. OF 2</p>  <p>18-0144 18-0144-9① REED BLOCK GASKET Replaces: 328626 For: 120-140 H.P V-4</p>
 <p>18-0148 INTAKE MANIFOLD GASKET Replaces: 329718 V-6</p>	 <p>18-0161 LOWER MANIFOLD GASKET Replaces: 331532 For: V-6</p>	 <p>18-0951 CARB TO MANIFOLD GASKET Replaces: 317305 3 Cyl.</p>	<p>PKG. OF 2</p>  <p>18-0959 18-0959-9① INNER LEAF PLATE GASKET Replaces: 318924 9.9 & 15 HP</p>	<p>PKG. OF 2</p>  <p>18-0963 18-0963-9① INTAKE MANIFOLD TWIN GASKET Replaces: 335633</p>

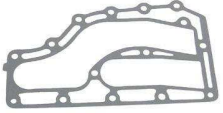
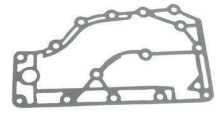
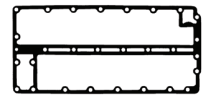
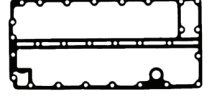



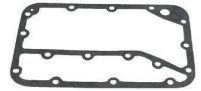



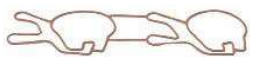

SEE PAGES 201-202 FOR OUR COMPLETE LINE OF GASKET SEALANTS

① Priced per package

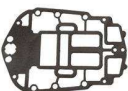
<p>PKG. OF 2</p>  <p>18-0981 18-0981-9① LEAF PLATE GASKET Replaces: 321479 25 & 35 HP</p>	<p>PKG. OF 2</p>  <p>18-0987 18-0987-9① THROTTLE BODY TO MANIFOLD GASKET Replaces: 332319</p>	<p>PKG. OF 2</p>  <p>18-0991 18-0991-9① LEAF PLATE GASKET Replaces: 321907 V-4/V-6</p>	<p>PKG. OF 2</p>  <p>18-0973 18-0973-9① CARB GASKET Replaces: 315052 V-4 Carburetor mounting includes: 100, 115, 125, 135, 140, 150, 175, 200, 235(1977-79), 85 (1969-79)</p>	 <p>18-1212 INTAKE MANIFOLD GASKET Replaces: 326926 For: 3 cyl.</p>
<p>PKG. OF 2</p>  <p>18-2862 18-2862-9① LEAF PLATE GASKET Replaces: 321573, 326260 25/35 HP</p>	<p>PKG. OF 2</p>  <p>18-2867 18-2867-9① MANIFOLD TO CRANKCASE GASKET Replaces: 319174 For: V-4</p>	 <p>18-0102 EXHAUST MANIFOLD GASKET Replaces: 323469 V-4</p>	<p>PKG. OF 2</p>  <p>18-0106 18-0106-9① EXHAUST MANIFOLD GASKET Replaces: 324323 25/35</p>	 <p>18-0117 EXHAUST PLATE GASKET Replaces: 317955 V-4</p>
 <p>18-0120 EXHAUST PLATE GASKET Replaces: 325211</p>	<p>PKG. OF 2</p>  <p>18-0126 18-0126-9① INNER EXHAUST COVER GASKET Replaces: 326264</p>	 <p>18-0927 INNER EXHAUST COVER GASKET 235 HP Replaces: 393561</p>	<p>PKG. OF 2</p>  <p>18-0999-9① INNER EXHAUST GASKET Replaces: 323459 V-4</p>	 <p>18-0945 OUTER EXHAUST GASKET Replaces: 336430, 323217</p>
 <p>18-0955 EXHAUST COVER GASKET Replaces: 318156 V-4</p>	 <p>18-1207 EXHAUST MANIFOLD GASKET Replaces: 329833, 343863</p>	 <p>18-1218 EXHAUST COVER GASKET Replaces: 315868</p>	 <p>18-1224 EXHAUST COVER GASKET Replaces: 315869</p>	<p>PKG. OF 2</p>  <p>18-2545 18-2545-9① EXHAUST PLATE GASKET Replaces: 321182 V-6</p>
<p>PKG. OF 2</p>  <p>18-2549 18-2549-9① EXHAUST COVER GASKET Replaces: 321435 V-6</p>	<p>PKG. OF 2</p>  <p>18-2853 18-2853-9① EXHAUST COVER GASKET Replaces: 318925 9.9/15 HP</p>	<p>PKG. OF 2</p>  <p>18-2866 18-2866-9① EXHAUST COVER GASKET Replaces: 317914 V-4</p>	<p>PKG. OF 2</p>  <p>18-2870 18-2870-9① EXHAUST COVER GASKET Replaces: 305176</p>	<p>PKG. OF 2</p>  <p>18-2871 18-2871-9① EXHAUST COVER GASKET Replaces: 304762</p>



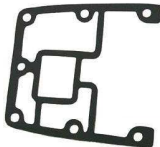
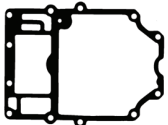
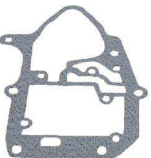

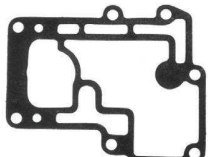
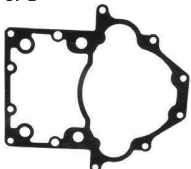





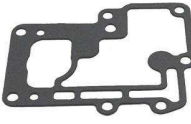
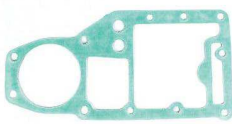













SEE PAGES 201-202 FOR OUR COMPLETE LINE OF GASKET SEALANTS

① Priced per package

 <p>18-2886 18-2886-9① COVER PLATE GASKET Replaces: 203171</p>	 <p>18-2913 18-2913-9① EXHAUST COVER GASKET Replaces: 331916, 319097 3 Cyl.</p>	 <p>18-2938 18-2938-9① EXHAUST COVER GASKET Replaces: 331917 3 Cyl.</p>	 <p>18-1283 MOLDED INTAKE PORT GASKET Replaces: 335818 For: V6 60° Eagle series 90-115HP (1995-00)</p>	 <p>18-1284 MOLDED INTAKE PORT GASKET Replaces: 335819 For: V6 60° Eagle series 90-115HP (1995-00)</p>
 <p>18-1285 MOLDED INTAKE PORT GASKET Replaces: 335403 For: V6 60° Eagle series 150-175HP (1991-00)</p>	 <p>18-0112 POWERHEAD BASE GASKET Replaces: 324717 9.9 & 15 HP</p>	 <p>18-0128 POWERHEAD BASE GASKET Replaces: 326468, 351018</p>	 <p>18-0136 POWERHEAD BASE GASKET Replaces: 328283</p>	 <p>18-0138 POWERHEAD BASE GASKET Replaces: 328590</p>
 <p>18-0690 BASE GASKET Replaces: 347205 Fits: 200 BB (1993 & Up), 200 Ficht FFI (1999-01), 225 BB (1993 & Up), 225 Ficht FFI (1999 & Up), 225 (2000-04), 250 Carb only (2000), 250 (2000-04), 3.3L (2000-04)</p>	 <p>18-0691 BASE GASKET Fits: 150 Ficht FFI, 175 Ficht FFI</p>	 <p>18-0692 BASE GASKET Replaces: 339601 Fits: 90 V4 60 degree (1995-00), 90 Ficht FFI, 1150V4 60 degree (1995-00), 115 Ficht FFI, 135 Ficht FFI, 150 60 degree (1991-00), 175 60 degree (1991-00)</p>	 <p>18-0693 INTAKE GASKET Replaces: 336227 Fits: 135(2005-06), 150(1991-98), 150(1991-06), 175(1991-06)</p>	 <p>18-0694 INTAKE GASKET Replaces: 336226 Fits: 135(2005-06), 150(1991-05), 175(1991-05)</p>
 <p>18-0695 INTAKE GASKET Replaces: 336389 Fits: 90(1995-06), 115(1995-06), 100(1998-01), 100(1998-01, 2005)</p>	 <p>18-0696 INTAKE GASKET Replaces: 336388 Fits: 90(1995-06), 100(1998-01, 2005), 115(1995-06)</p>	 <p>18-0957 POWERHEAD BASE GASKET Replaces: 318373</p>	 <p>18-0965 ADAPTER OUTER POWERHEAD GASKET Replaces: 333879</p>	 <p>18-0995 POWERHEAD BASE GASKET Replaces: 323222 V-6</p>
 <p>18-1205 18-1205-9① ADAPTER COVER GASKET Replaces: 329828</p>	 <p>18-2550 18-2550-9① POWERHEAD BASE GASKET Replaces: 323214 V-6</p>	 <p>18-2852 18-2852-9① POWERHEAD BASE GASKET Replaces: 330621 25/35 HP</p>	 <p>18-2864 18-2864-9① POWERHEAD BASE GASKET Replaces: 321727 V-4</p>	 <p>18-2865 18-2865-9① POWERHEAD BASE GASKET Replaces: 313763 3 Cyl.</p>
 <p>18-2868 18-2868-9① POWERHEAD BASE GASKET Replaces: 310137 35/40 HP</p>	 <p>18-2877 18-2877-9① BAFFLE GASKET Replaces: 314421 18/25 HP</p>	 <p>18-2878 18-2878-9① BAFFLE GASKET Replaces: 319710 25/35</p>	 <p>18-2894 18-2894-9① EXHAUST HOUSING GASKET Replaces: 304314</p>	 <p>18-2898 18-2898-9① POWERHEAD BASE GASKET Replaces: 309956 V-4</p>











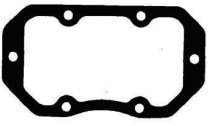



SEE PAGES 201-202 FOR OUR COMPLETE LINE OF GASKET SEALANTS

① Priced per package

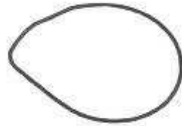
<p>PKG. OF 2</p>  <p>18-2901 18-2901-9^① EXHAUST HOUSING GASKET Replaces: 313065, 306205 5, 5.5, 6 HP</p>	<p>PKG. OF 2</p>  <p>18-2904 18-2904-9^① EXHAUST PLATE GASKET Replaces: 319348 28, 33, 40 HP</p>	<p>PKG. OF 2</p>  <p>18-2907 18-2907-9^① EXHAUST HOUSING GASKET Replaces: 325721</p>	<p>PKG. OF 2</p>  <p>18-0967 18-0967-9^① BYPASS COVER GASKET Replaces: 319332 9.9 & 15 HP</p>	 <p>18-0971 BYPASS GASKET Replaces: 319661 25 & 35 HP</p>
<p>PKG. OF 2</p>  <p>18-2876 18-2876-9^① BYPASS COVER GASKET Replaces: 307133</p>	 <p>18-0941 WATER JACKET GASKET Replaces: 315538 50/55 HP</p>	<p>PKG. OF 2</p>  <p>18-2543 18-2543-9^① WATER JACKET GASKET Replaces: 318609 3 Cyl.</p>	 <p>18-0892 DEFLECTOR HOSE Replaces: 322411</p>	<p>PKG. OF 2</p>  <p>18-2544 18-2544-9^① WATER JACKET GASKET Replaces: 321028 V-6</p>
<p>PKG. OF 2</p>  <p>18-2856 18-2856-9^① WATER JACKET GASKET Replaces: 319665 25/35 HP</p>	 <p>18-3899 WATER COVER GASKET Replaces: 327674 For: 20, 25, 25C, 30, 35</p>	<p>PKG. OF 2</p>  <p>18-2872 18-2872-9^① WATER JACKET GASKET Replaces: 307257, 318334 V-4</p>	<p>PKG. OF 2</p>  <p>18-2873 18-2873-9^① WATER JACKET GASKET Replaces: 318335 V-4</p>	<p>PKG. OF 2</p>  <p>18-2905 18-2905-9^① WATER COVER GASKET Replaces: 329920 9.9, 15 HP</p>
 <p>18-3360 IMPELLER HOUSING GASKET Replaces: 329390 20-25 HP</p>	<p>PKG. OF 2</p>  <p>18-0182 18-0182-9^① THERMOSTAT GASKET Replaces: 310058</p>	<p>PKG. OF 2</p>  <p>18-0397 THERMOSTAT GASKET Replaces: 318917</p>	<p>PKG. OF 2</p>  <p>18-0412 18-0412-9^① THERMOSTAT GASKET Replaces: 337068</p>	<p>PKG. OF 2</p>  <p>18-0441 18-0441-9^① THERMOSTAT GASKET Replaces: 329076</p>
<p>PKG. OF 2</p>  <p>18-0929 18-0929-9^① THERMOSTAT GASKET Replaces: 313416 3 Cyl.</p>	<p>PKG. OF 2</p>  <p>18-0675 THERMOSTAT GASKET Replaces: 321932 V-4</p>	<p>PKG. OF 2</p>  <p>18-0977 18-0977-9^① THERMOSTAT GASKET Replaces: 332369 V-4</p>	<p>PKG. OF 2</p>  <p>18-1202 18-1202-9^① THERMOSTAT GASKET Replaces: 329830</p>	 <p>18-1222 THERMOSTAT GASKET Replaces: 394408</p>

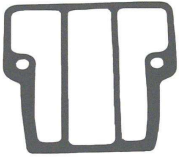



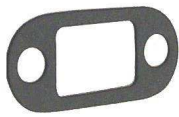







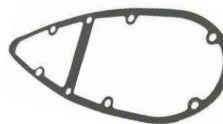











SEE PAGES 201-202 FOR OUR COMPLETE LINE OF GASKET SEALANTS

① Priced per package

<p>PKG. OF 2</p>  <p>18-2547 18-2547-9^① WATER PASSAGE GASKET Replaces: 322858 V-4/V-6</p>	<p>PKG. OF 2</p>  <p>18-2548 18-2548-9^① THERMOSTAT GASKET Replaces: 332108 3 Cyl.</p>	<p>PKG. OF 2</p>  <p>18-2546 18-2546-9^① THERMOSTAT GASKET Replaces: 321184 V-6</p>	<p>PKG. OF 2</p>  <p>18-0124 18-0124-9^① IMPELLER PLATE GASKET Replaces: 325537</p>	<p>PKG. OF 2</p>  <p>18-0445 18-0445-9^① WATER PUMP GASKET Replaces: 323312 35HP</p>
 <p>18-0446 WATER PUMP GASKET Replaces: 323311 35HP</p>	<p>PKG. OF 2</p>  <p>18-0969 18-0969-9^① IMPELLER HOUSING GASKET Replaces: 319586</p>	<p>PKG. OF 5</p>  <p>18-2536 18-2536-9^① IMPELLER HOUSING SEAL Replaces: 321120 V-4, V-6</p>	<p>PKG. OF 5</p>  <p>18-2539 18-2539-9^① RUBBER SEAL Replaces: 328753</p>	<p>PKG. OF 2</p>  <p>18-2557 18-2557-9^① IMPELLER GASKET Replaces: 324701, 338484 V-4, V-6, V-8</p>
<p>PKG. OF 2</p>  <p>18-2709 18-2709-9^① WEAR PLATE GASKET Replaces: 336530</p>	<p>PKG. OF 2</p>  <p>18-0679 THERMOSTAT GASKET Replaces: 311145</p>	<p>PKG. OF 2</p>  <p>18-7428 18-7428-9^① O-RING Replaces: 307103</p>	<p>PKG. OF 2</p>  <p>18-7481 18-7481-9^① O-RING Replaces: 324981</p>	<p>PKG. OF 2</p>  <p>18-0155 18-0155-9^① RECTIFIER MOUNTING GASKET Replaces: 330412</p>
<p>PKG. OF 2</p>  <p>18-0851 18-0851-9^① RELIEF GASKET Replaces: 329826</p>	<p>PKG. OF 2</p>  <p>18-0953 18-0953-9^① WATER PASSAGE GASKET Replaces: 317951 V-4/V-6</p>	<p>PKG. OF 2</p>  <p>18-0110 18-0110-9^① SHIFT HOUSING GASKET Replaces: 324670</p>	<p>PKG. OF 2</p>  <p>18-0313 SHIFT ROD GASKET Replaces: 352165 For: E-Tec 75/90/115/150/ 175/200/225/250 HP</p>	<p>PKG. OF 2</p>  <p>18-0882 18-0882-9^① SHIFT ROD GASKET Replaces: 304764</p>
<p>PKG. OF 2</p>  <p>18-2855 18-2855-9^① SHIFT HOUSING GASKET Replaces: 314082</p>	<p>PKG. OF 2</p>  <p>18-2874 18-2874-9^① SOLENOID COVER GASKET Replaces: 314876 V-4</p>	<p>PKG. OF 2</p>  <p>18-2880 18-2880-9^① COVER PLATE GASKET Replaces: 304023</p>	<p>PKG. OF 2</p>  <p>18-0108 18-0108-9^① LOWER GEAR CASE GASKET Replaces: 324449</p>	

SEE PAGES 201-202 FOR OUR COMPLETE LINE OF GASKET SEALANTS

① Priced per package

 <p>18-0540 EXHAUST LEG RUBBER SEAL Replaces: 320936</p>	<p>PKG. OF 2</p>  <p>18-0949 18-0949-9① TRUNION CAP GASKET Replaces: 316499</p>	 <p>18-2537 EXHAUST SEAL LEG Replaces: 324937</p>	<p>PKG. OF 2</p>  <p>18-2869 18-2869-9① EXHAUST HOUSING GASKET Replaces: 305312</p>	<p>PKG. OF 2</p>  <p>18-2891 18-2891-9① BEARING HOUSING GASKET Replaces: 303339 6HP</p>
 <p>18-8353 OIL SEAL Replaces: 320961</p>	 <p>18-1219 GROMMET Replaces: 320880</p>	 <p>18-2389 GROMMET Replaces: 314832</p>	 <p>18-2391 GROMMET Replaces: 321692</p>	 <p>18-2392 GROMMET Replaces: 327035</p>
<p>PKG. OF 2</p>  <p>18-2703 18-2703-9① GROMMET Replaces: 314008</p>	 <p>18-2704 GROMMET Replaces: 320943</p>	<p>PKG. OF 2</p>  <p>18-2706 18-2706-9① GROMMET Replaces: 321008</p>	<p>PKG. OF 2</p>  <p>18-2708 18-2708-9① GROMMET Replaces: 333758</p>	 <p>18-3329 GROMMET Replaces: 302497 9.9-35 HP</p>
 <p>18-3332 GROMMET Replaces: 304026</p>	 <p>18-3337 GROMMET Replaces: 315837 40-50 HP</p>	<p>PKG. OF 2</p>  <p>18-1221 18-1221-9① RETAINER GASKET Replaces: 330273</p>	 <p>18-2532 GEARCASE COVER SEAL Replaces: 305762 2 Cyl.</p>	 <p>18-2534 SEAL 40" Replaces: 309044 Material equivalent to that of O.E. spool # 309044 0.1005 O.D.</p>
 <p>18-7963 O-RING Replaces: 331353</p>	<p>PKG. OF 2</p>  <p>18-2705 18-2705-9① OIL SEAL Replaces: 315748</p>	<p>PKG. OF 2</p>  <p>18-2769 18-2769-9① RUBBER SEAL Replaces: 332000</p>	<p>PKG. OF 2</p>  <p>18-0917 TILT MOTOR GASKET Replaces: 311508</p>	 <p>18-8372 MOLDED SEAL Replaces: 323582 For: 5 & 7.5 HP (1978-83) Outboards</p>

SEE PAGES 201-202 FOR OUR COMPLETE LINE OF GASKET SEALANTS

① Priced per package

PKG. OF 2



18-2881
18-2881-9^④
HOUSING TO TANK GASKET
Replaces: 332403, 125530
For: 6 Gallon Fuel Tank

PKG. OF 2



18-2887
18-2887-9^④
FUEL TANK GASKET
Replaces: 302557



18-1704
SCREW
Replaces: 331980
For: Waterpumps, power packs (1985-96)



18-4904
STARTER HANDLE & ROPE
(Uses 9/64" Rope)
Handle Only: **18-4901**

STARTER ROPE

18-4911
5/32" x 200'
Replaces: 322236, 772577

18-4913
3/16" x 200'
Replaces: 316705, 772578

18-4914
1/8" x 200'
Replaces: 316706, 772579



18-1505
STARTER GEAR
Replaces: 318940
For: 9.9 - 15HP (1974-1992)



18-6501
REWIND SPRING
Replaces: 395460, 307573



18-6503
REWIND SPRING
Replaces: 318944



18-6509
REWIND SPRING
Replaces: 326877



18-6511
REWIND SPRING
Replaces: 312932



18-6522
REWIND SPRING
Replaces: 323653, 338534

H.P.	YEARS	REWIND SPRING
2	1969-80	18-6511
3	1954-68	18-6501
4 ^①	1969-92	18-6511
4 ^②	1969-80	18-6511
4 ^③	1981-92	18-6509

^① 1992 4D Models only
^② Except 4D

H.P.	YEARS	REWIND SPRING
4.5	1980-90	18-6511
5.5	1954-68	18-6501
7.5	1954-68	18-6501
9.9	1980-92	18-6522
9.9	1974-78	18-6503
10	1980-92	18-6522

^③ All 4D

H.P.	YEARS	REWIND SPRING
10	1950-63	18-6501
12	1980-92	18-6522
12	1956-68	18-6501
15	1979-92	18-6522
15	1956-68	18-6501
15	1974-78	18-6503

H.P.	YEARS	REWIND SPRING
18	1968-73	18-6501
20	1956-73, 85-97	18-6501
28	1969-92	18-6501
25	1969-05	18-6501
30	1984-05	18-6501
35	1976-94	18-6501

PKG. OF 3



18-6513
18-6513-9^④
STARTER PAWL
Replaces: 203698

PKG. OF 2



18-6512
18-6512-9^④
STARTER PAWL
Replaces: 330525

HP	Years	Pawl	HP	Years	Pawl	HP	Years	Pawl
2	1971-88	18-6513	18	1957-73	18-6513	30	1984-90	18-6512
Jr/Colt	1990	18-6513	20	1981-90	18-6512	35	1976-77	18-6513
3	1957-67	18-6513	25	1969-76	18-6513	35	1978-90	18-6512
4	1978-90	18-6513	25	1977	18-6513	45	1958-59	18-6513
5.5	1957-64	18-6513	25	1978-90	18-6512	50	1958-89	18-6513
7.5	1957-76	18-6513	25C	1982-90	18-6512	60	1964-66	18-6513
10	1957-62	18-6513	30	1957-61	18-6512	75	1960-65	18-6513
						80	1966	18-6513

SEE PAGES 201-202 FOR OUR COMPLETE LINE OF GASKET SEALANTS

^④ Priced per package

ALWAYS GET A PERFECT FIT

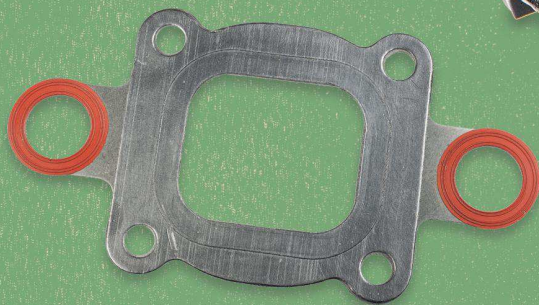

ALL SIERRA MANIFOLDS:

- **Manufactured as a direct OE replacement and are fully interchangeable with the OEM products they are designed to replace.**
- **Includes all the necessary gaskets and hardware for easy, out-of-the-box installation.**
- **Revised gasket material for more compressibility and better sealing properties.**
- **All manifolds are primed and painted for added durability, protection. Components are ready to install out-of-the box.**
- **Packaged for maximum protection during shipping and handling.**
- **Backed by Sierra's Comprehensive Warranty.**

The Very Best Parts of Boating
www.sierramarine.com

Sierra
Marine Engine and Drive Parts

...killed himself and wounded his woman companion in an automobile on the El Camino Real late today as a policeman approached...

SHOW-DOWN IN RECOVERY ROAD

ROME, Aug. 12.—Racing in from the Mediterranean, General Italo Balbo's mighty air fleet returned from America to-night to a thunderous reception...

...night for the plane bearing deposed President Gerardo Machado from Cuba, but up to a late hour there had been no word of the big craft. It was pointed out that the president...

...which hindered Carlos Machado and acts of speed...

...husband, a bullet bedraggled that was a glorious E and murdered manche Ba chure was in jail at...

SEVEN WAS AFTER

...ent Plea Events In With E

FREDE... Press St WASHINGTON Roosevelt House to study of the after a day

...velt indic at the tur evolution i old have r the situa ternity of veit start mburg, V doah Vall ne by ap and, New mp in al ship was

...made to the s ordered as one e program (or com ment. He was ac retary of the Int tary of Agricultu ant Secretary T members of his ' retriat, Colonel Howe and Colon

...Another heads for the engine room. A third rounds up the passengers and other members of the crew. A systematic looting of the ship's valuables and robbing of the passengers follows.

Little Resistance

Possibly not as colorful as the brigands who sailed the Spanish Main, but just as ruthless, the n...

...cially prominent artist, fell or jumped two stories to-day from the home of her aunt, Mrs. Herbert A. Schmidt.

Dr. Frederick Eberson said Mrs. Gildersleeve was conscious when she arrived, and murmured "I have swallowed some tablets. I do not wish to live any more."

...in perfect formation, streaming over the mouth of the Tiber while Mussolini watched closely from his box.

General Balbo emerged from the cockpit of his craft as it reached the landing stage. He walked immediately toward the premier. Behind him followed his pilots, all of whom were congratulated by the

...15 cents he taxed?

Second—Can merchants legally absorb the tax themselves, instead of passing it on to the consumer, and thus gain a competitive advantage over ethical competitors?

The board's solution to the first question was contained in an official statement.

Scrip Plan

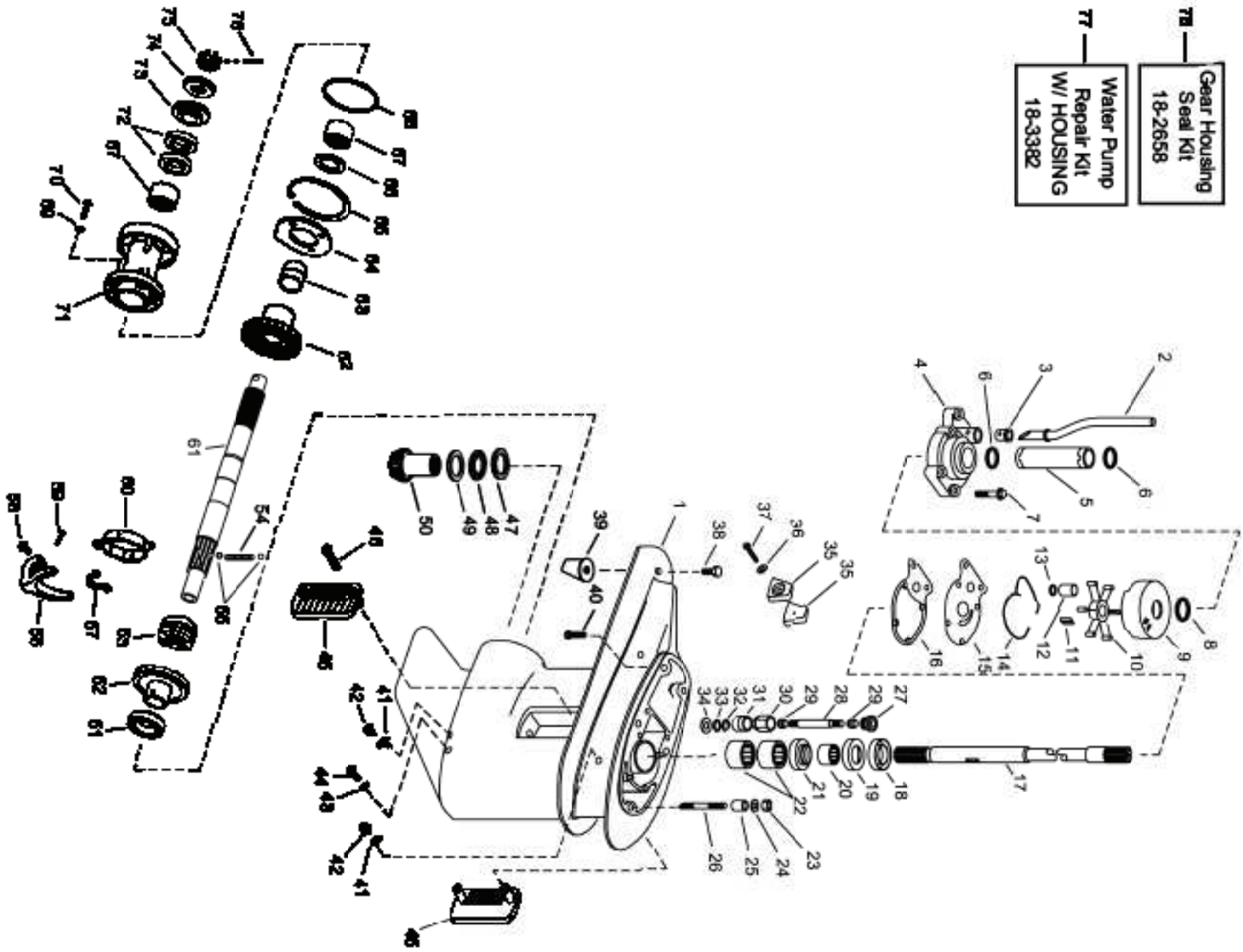

Complete Gear Housings Listed on Page 328

Figure #	Description	Part #	O.E.M. #	Qty.	Figure #	Description	Part #	O.E.M. #	Qty.
1	Gear Housing	—	434030	1	46	Screw, Screen Retaining	—	325539	2
2	Tube Water	—	395339	1	47	Washer, Thrust	—	327716	1
3	Grommet	18-3329	302497	1	48	Bearing, Thrust	—	388027	1
4	Housing, Water Pump	18-3367	393632	1	49	Washer, Thrust	—	330441	1
5	Tube, Extension	—	326692	1	50	Gear, Pinion	18-1288	328313	1
6	O-Ring	18-7105	311338	2	51	Bearing, Forward Gear	—	386186	1
7	Bolt, Water Pump Housing	—	328725	6	52	Gear, Forward	18-1287	392475	1
8	O-Ring	18-7146	554545	1	53	Clutch Sliding	18-1290	337020	1
9	Insert, Water Pump Housing	18-3358	328751	1	54	Spring, Detent	—	327070	1
10	Impeller	18-3051	395289	1	55	Ball, Detent	18-2243	316506	2
11	Key, Water Pump	18-3295	344470	1	56	Lever Shifter	—	337019	1
12	Bushing	—	328754	1	57	Cradle, Sliding Clutch	—	438311	1
13	O-Ring	18-7100	301877	1	58	Pin, Shift	—	302504	1
14	Seal, Rubber	18-2539	328753	1	59	Cotterpin, Shift Lever	—	303049	1
15	Plate, Wear	18-3359	328753	1	60	Yoke & Connector Assy.	—	390023	1
16	Gasket, Water Pump	18-0124	325537	1	61	Shaft, Propeller	—	439143	1
17	Drive Shaft (15")	—	341635	1	62	Gear, Reverse	18-1289	327655	1
	Drive Shaft (20")	—	341636	1	63	Bushing, Reverse Gear	—	319635	1
18	Seal Drive Shaft (upper)	18-2065	332261	1	64	Plate, Retainer	—	319746	1
19	Seal Drive Shaft (lower)	18-2033	321938	1	65	Ring, Retaining	—	319747	1
20	Bearing, Driveshaft	—	386473	1	66	Washer, Forward Gear Thrust	—	319684	1
21	Collar, Housing	—	322018	1	67	Bearing, Propshaft	—	437288	2
22	Bearing, Pinion	—	437288	2	68	O-Ring	18-7108	338518	1
23	Nut, Housing	—	306422	1	69	Seal	18-7475	332584	2
24	Washer, Locking	—	301250	1	70	Bolt, Carrier Retaining	—	319743	2
25	Bushing, Housing Alignment	—	319785	1	71	Carrier, Bearing	—	433428	1
26	Stud	—	320173	1	72	Seal, Propshaft	18-2026	321453	2
27	Connector, Shift	—	325624	1	73	Spacer, Prop	18-4229	319890	1
28	Shift Rod	—	331479	1	74	Spacer, Prop	18-4232	323943	1
29	Keeper, Nylon Shift	—	325625	2	75	Prop Nut	18-3707	319891	1
30	Nut, Shiftshaft Retaining	—	331465	1	76	Cotter Pin, Prop Nut	18-3743	320785	1
31	Bushing	—	326361	1	77	Water Pump Kit	18-3382	393639	1
32	O-Ring	18-7180	303347	1	78	Gear Housing Seal Kit	18-2658	396351	1
33	O-Ring	18-7100	301877	1					
34	Washer, Expanding	18-0189	321738	1					
35	Anode Kit	—	434029	1					
36	Lockwasher	—	304454	1					
37	Bolt, Anode Retaining	—	333677	1					
38	Bolt, Trim Tab Retaining	—	329217	1					
39	Trim Tab	—	336203	1					
40	Bolt, Housing Retaining	—	328333	4					
41	Gasket, Drain Plug	18-4248	311598	2					
42	Plug, Drain	18-2387	307551	2					
43	Seal	18-7475	332584	1					
44	Pin, Shift Lever Pivot	—	308376	1					
45	Screen, Water Inlet	—	336202, 336206	2					

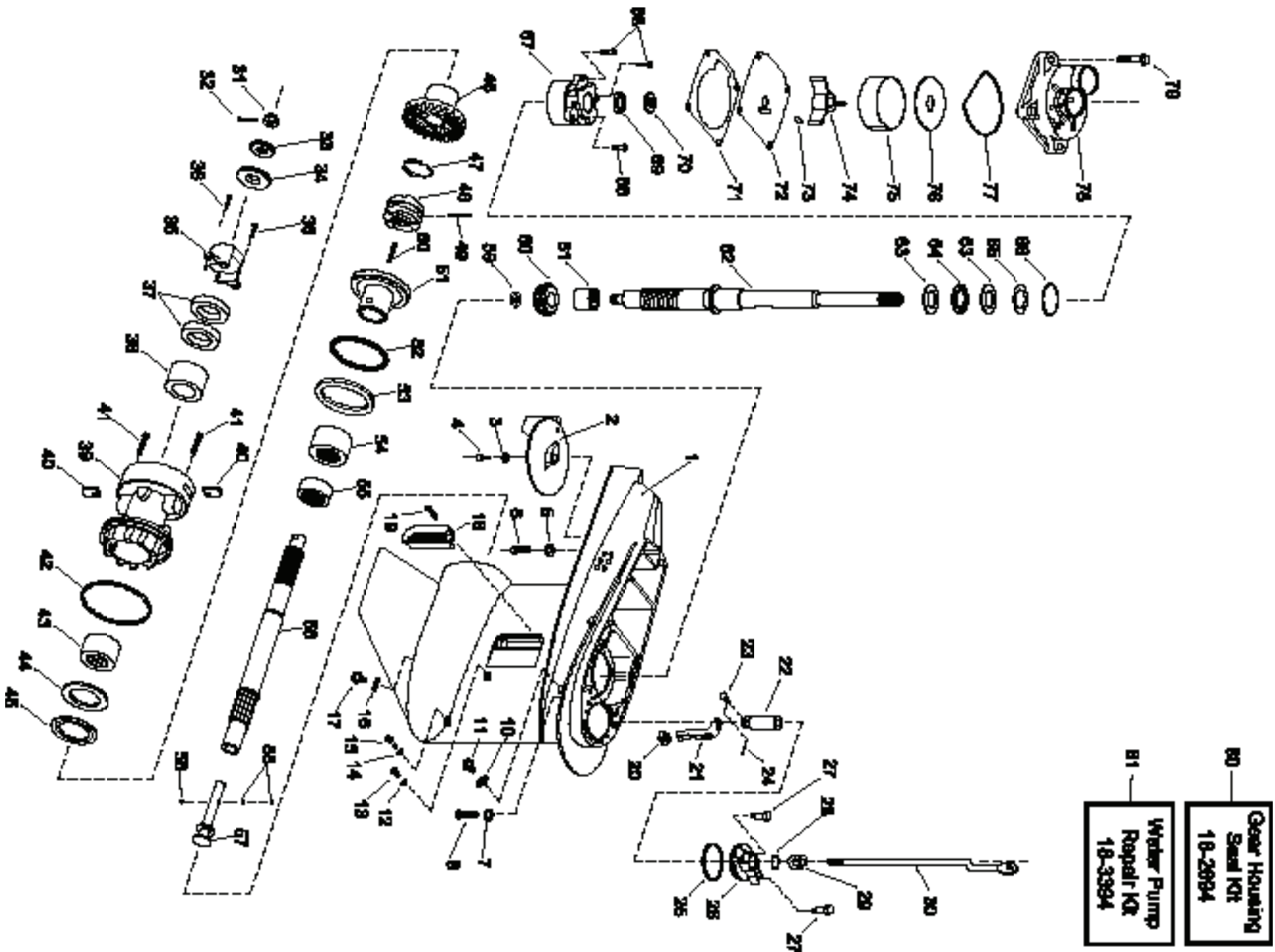

Complete Gear Housings Listed on Page 328

Figure #	Description	Part #	O.E.M. #	Qty.	Figure #	Description	Part #	O.E.M. #	Qty.
1	Housing, Gearcase	—	435275	1	47	Spring Clutch	18-2398	320311	1
2	Trim Tab	—	340539	1	48	Clutch Sliding	18-2308	332491	1
3	Washer, Anode	—	330266	1	49	Pin, Clutch Cross	—	320310	1
4	Bolt, Anode Retaining	—	330930	1	50	Spring Shifter	—	332484	1
5	Washer	—	330265	1	51	Gear Set, Forward & Pinion	18-2310	397627	1
6	Bolt	—	313697	1	52	Thrust Bearing, Forward Gear	18-1364	397538	1
7	Washer	—	330266	4	53	Thrust Washer, Forward Gear	18-0197	333725	1
8	Bolt	—	305282	4	54	Bearing Forward, Outer	18-1351	382407	1
10	O-Ring	18-4253-9	336982	1	55	Thrust Bearing, Forward Gear	18-1369	432264	1
11	Drain Plug, Upper	18-1236	309243	1	56	Propeller Shaft	18-2288	439138	1
12	Seal	18-7475	332584	1	57	Shaft, Shift Dog	—	332503	1
13	Retaining Screw	—	324852	1	58	Ball, Detent	18-2243	316506	3
14	O-Ring Screw	18-7109	317178	1	59	Nut, Pinion	—	313339	1
15	Screw, Shift Lever	—	333770	1	60	Gear Set, Forward & Pinion	18-2310	397627	1
16	Gasket, Drain Plug	18-4248	311598	1	61	Bearing Pinion	18-1356	382343	1
17	Drain Fill Plug, Lower	18-2378	318544	1	62	Driveshaft (std)	—	433066	1
18	Screen, Water Intake	—	332494	2		Driveshaft (long)	18-1721	433067	1
19	Bolt, Inlet Screen Retainer	—	325539	2	63	Washer, Thrust	18-0201	333771	2
20	Cradle, Shifter	—	332507	1	64	Thrust Bearing, Driveshaft	18-1368	398901	1
21	Lever, Shift	—	332492	1	65	Shim (.003)	—	313273	AR
22	Connector, Shift Rod	—	332508	1		Shim (.004)	—	313274	AR
23	Pin, Connector	—	302504	1		Shim (.005)	—	313275	AR
24	Cotter Pin	—	306376	1		Shim (.006)	—	313276	AR
25	O-Ring, Shift Rod Cover	—	338522	1		Shim (.007)	—	313277	AR
26	Cover, Shift Rod	18-1729	434588	1	66	O-Ring, Gear Housing	18-7173	310327	1
27	Bolt, Shift Rod Cover	—	316037	2	67	Cap, Upper Driveshaft, Retaining	—	435274	1
28	O-Ring, Shift Rod	18-7137	318372	1	68	Bolt, Driveshaft Retaining	—	317624	3
29	Bushing, Shift Rod	—	333780	1	69	Seal Lower	18-2059	321466	1
30	Shift Rod (std.)	—	332509	1	70	Seal Upper	18-2064	332205	1
	Shift Rod (long)	—	332510	1	71	Gasket, Impeller	18-2709	336530	1
31	Nut, Prop	18-3705	314503	1	72	Plate, Impeller	NSS	341038	1
32	Pin, Cotter	18-3742	314502	1	73	Key, Impeller	18-3138	334897	1
33	Spacer, Prop	18-4228	315810	1	74	Impeller	18-3104-1	432941	1
34	Washer, Prop Thrust	18-4230	320305	1	75	Skirting, Insert	NSS	324980	1
35	Anode, Bearing Housing	—	398873	1	76	Plate, Insert Top	18-3126	321940	1
36	Bolt, Anode Retaining	—	328694	2	77	Seal, Rubber	18-7481	324981	1
37	Oil Seals, Prop Shaft	18-2060	321467	2	78	Housing, W/P	18-3129	438544	1
38	Bearing, Needle	18-1355	386765	1	79	Bolt, Water Pump Housing	18-3369	302325	4
39	Bearing Carrier Assembly	18-1708	432276	1	80	Gear Housing Seal Kit	18-2694	433550	1
40	Tabs, Retaining	18-1343	332495	2	81	Water Pump Repair Kit	18-3394	433548	1
41	Bolt, Carrier Retaining	—	328744	2					
42	O-Ring, Bearing Housing	18-7172	553126	1					
43	Bearing, Needle	18-1354	386764	1					
44	Thrust Washer, Reverse Gear	18-0196	332514	1					
45	Thrust Bearing, Reverse Gear	18-1363	397537	1					
46	Gear, Reverse	18-2309	332489	1					

AR As required

NSS Not Sold Separate

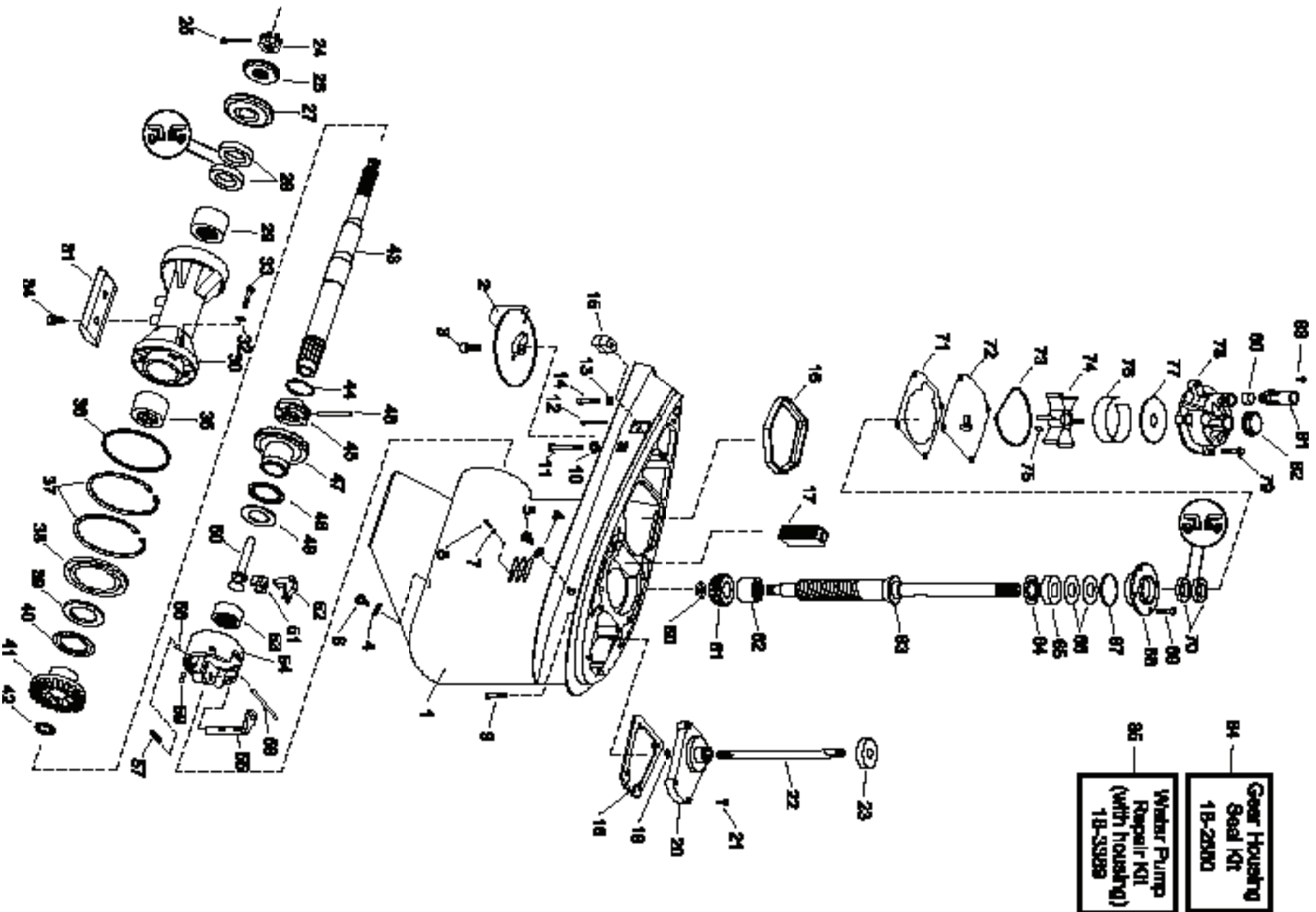

Complete Gear Housings Listed on Page 328

Figure #	Description	Part #	O.E.M. #	Qty.	Figure #	Description	Part #	O.E.M. #	Qty.
1	Housing Gearcase	—	392478	1	43	Propshaft	18-2250	439185,	1
2	Trim Tab	—	318544	1			439131		
3	Bolt, Trim Tab	—	313715	1	44	Retaining Spring	18-2399	324369	1
4	O-Rings, Drain Plugs	18-7145	333572	2	45	Clutch Sliding	18-2209	318303	1
5	Drain Fill Plug, Upper	18-2387	307551	1	46	Pin, Clutch Dog	18-1714	313448	1
6	Magnetic Drain Screw	18-2378	318544	1	47	Gear Set, Forward & Pinion	—	397338	1
7	Seal	18-7475	332584	1	48	Thrust Bearing, Forward Gear	18-1371	385043	1
8	Bolt, Pinion Retaining	—	324852	1	49	Thrust Washer, Forward Gear	18-0198	324766	1
9	Bolt, Housing	—	308843	4	50	Shaft, Shifter	—	326668	1
10	Lockwasher	—	306314	1	51	Cradle, Shifter	18-3766	334163	1
11	Bolt, Long Gearcase	—	313697	1	52	Lever, Shift	—	324037	1
12	Bolt, Anode	—	328096	1	53	Bearing, Housing	NSS	NSS	
13	Lockwasher	—	306470	1	54	Bearing Housing Assy.	—	391365	1
14	Bolt, Short Gearcase	—	306503	1	55	Detent Shift	—	326670	1
15	Anode, Cavitation	18-6024	436745	1	56	Detent Ball	—	327345	1
16	Seal, Exhaust	18-2537	324937	1	57	Detent Spring	—	911961	1
17	Screen, Water Inlet	—	314175	1	58	Pin, Shifter Housing	—	320145	1
18	Gasket, Shiftshaft Housing	18-2855	314082	1	59	Pin, Housing	18-3765	331880	1
19	O-Rings, Shiftshaft	18-7137	318372	1	60	Nut, Pinion	—	313339	1
20	Shiftshaft Housing	—	388651	1	61	Gear, Pinion	NSS	NSS	
21	Bolt, Shiftshaft Housing	18-3133	302325	4	62	Bearing, Pinion	18-1356	382343	1
22	Shiftshaft	—	327337	1	63	Driveshaft(std)	—	437376	1
23	Slinger, Shift Arm	18-2706	321008	1	64	Bearing, Thrust	—	317230	1
24	Nut, Propeller	18-3705	314503	1	65	Washer, Thrust	18-1367	385068	1
25	Cotter Pin, Prop Nut	18-3742	314502	1	66	Shim (.003)	18-2232	323889	AR
26	Spacer, Prop Nut	18-4228	315810	1	66	Shim (.004)	18-2233	323890	AR
27	Thrust Washer	18-4222	127084, 318841	1	66	Shim (.005)	18-2234	317232	AR
28	Outer Seal, Carrier	18-8326	330137	1	67	O-Ring Bearing Housing	18-7128	313754	1
28	Inner Seal, Carrier	18-2001	342787	1	68	Driveshaft Retaining Housing	—	385087	1
29	Carrier Bearing (Aft)	18-1350	379504	1	69	Bolt, Driveshaft Retaining	—	909386	4
30	Carrier Assembly	—	434391	1	70	Seal	18-8325	342786	1
31	Anode, Carrier	—	306470	1	71	Gasket, Water Pump	18-2709	336530	1
32	Seal	18-7475	332584	4	72	Plate, Impeller	18-3127	341038	1
33	Bolt, Carrier to Retainer	18-2379	320041	4	73	Seal, Water Pump Housing	18-7481	324981	1
34	Bolt, Carrier Anode	—	127466	2	74	Impeller	18-3053-1	396725	1
35	Carrier Bearing (Fore)	18-1351	382407	1	75	Key, Impeller	18-3138	334897	1
36	O-Ring , Bearing Housing	18-7127	313446	1	76	Liner, Water Pump Housing	—	321940	1
37	Retaining Rings	—	313445	2	77	Liner, Top Plate	18-3126	324980	1
38	Retaining Plate, Carrier	—	313453	1	78	Housing, Water Pump	18-3129	435673	1
39	Large Thrust Washer, Reverse Gear	18-0193	313447	1	79	Bolt, Water Pump Housing	18-3133	302325	1
40	Thrust Bearing, Reverse Gear	18-1366	382408	1	80	Seal, Guide tube	18-2703	314008	1
41	Gear, Reverse	18-2208	318304	1	81	Guide, Water Tube	—	319276	1
42	Small Thrust Washer, Reverse Gear	—	316484	1	82	Grommet	18-2705	342786	1
					83	Screw, Guide Tube	18-3153	908158	1
					84	Gear Housing Seal Kit	18-2660	396349	1
					85	Water Pump Repair Kit, Complete	18-3389	432955	1

AR As required

NSS Not Sold Seperate

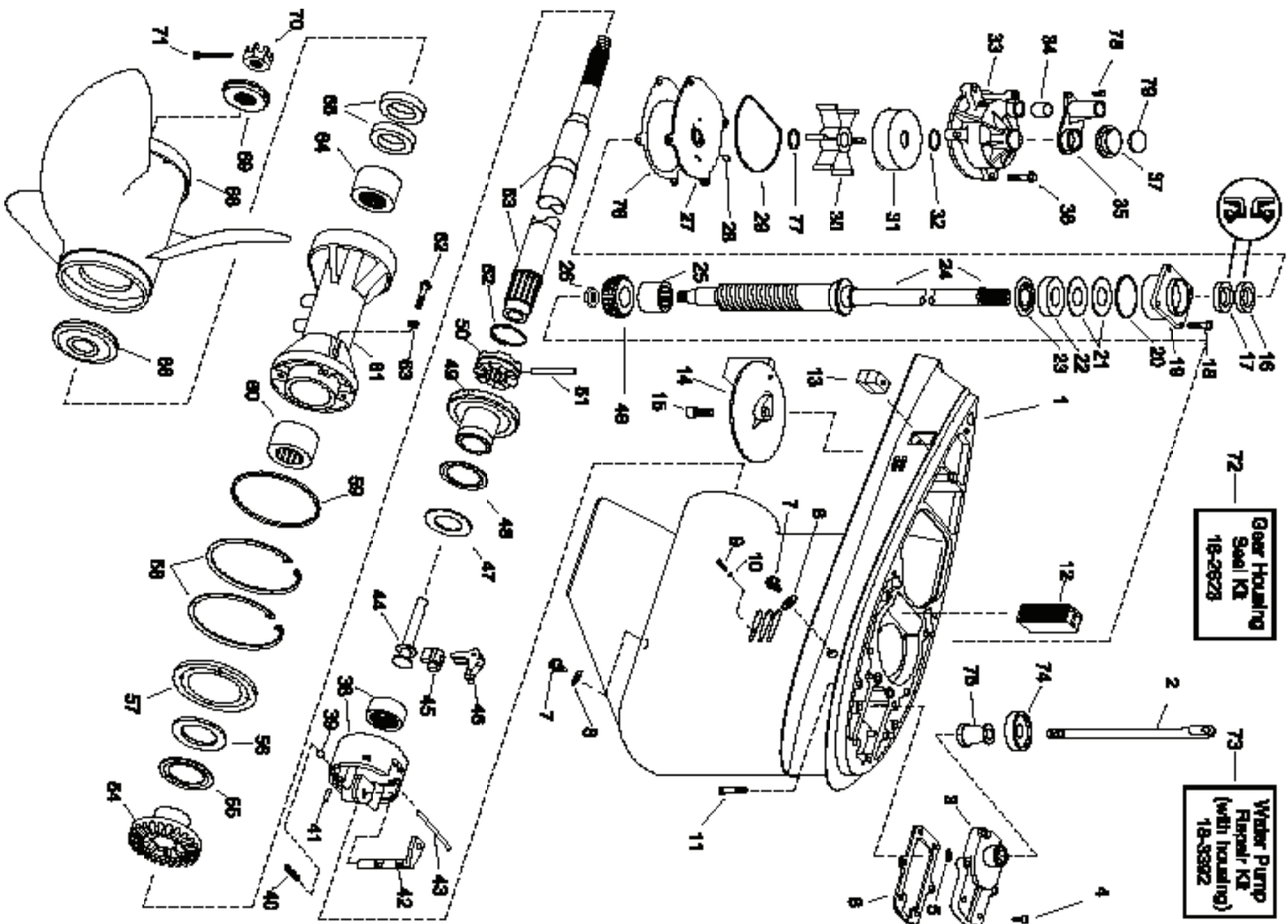

Complete Gear Housings Listed on Page 328

Figure #	Description	Part #	O.E.M. #	Qty.	Figure #	Description	Part #	O.E.M. #	Qty.
1	Housing Gearcase	—	431642	1	43	Pin, Shift Lever	—	320145	1
2	Shift Rod (long)	—	332120	1	44	Shift Shaft	18-3763	322941	1
	Shift Rod (x-long)	—	332121	1	45	Cradler, Shifter	18-3766	334163	1
3	Cover, Shift Rod	—	388618	1	46	Shift Lever	—	324037	1
4	Screw, Cover	18-3369	302325	6	47	Thrust Washer, Forward Gear	18-0198	324766	1
5	O-Ring, Shift Rod	18-7137	318372	1	48	Thrust Bearing, Forward Gear	18-1371	385043	1
6	Gasket, Shift Housing	18-0110	324670	1	49	Gear Set, Forward & Pinion	18-2218	398035	1
7	Magnetic Drain Screw	18-2378	318544	1	50	Sliding Clutch	18-2220	323664	1
8	O-Rings, Plugs	18-7145	333572	1	51	Pin, Clutch Dog	18-1714	313448	1
9	Screw	—	324852	1	52	Retaining Spring	18-2399	324369	1
10	O-Ring	18-7475	332584	1	53	Propeller Shaft	18-2252	387818	1
11	Screw, Gearcase to housing	—	331999	5	54	Gear, Reverse	18-2219	333077	1
12	Screen, Water intake	—	323466	1	55	Thrust Bearing, Reverse Gear	18-1366	382408	1
13	Anode	18-6024	393023	1	56	Thrust Washer, Reverse Gear	18-0195	314731	1
14	Trim Tab	—	327640	1	57	Retainer Plate/Bearing Housing	—	314732	1
15	Screw, Trim tab	—	313715	1	58	Retaining Rings	—	313445	2
16	Oil Seal, Upper	18-2061	329922	1	59	O-Ring, Bearing Housing	18-7127	313446	1
17	Oil Seal, Lower	18-2062	329923	1	60	Carrier Bearing (Fore)	18-1351	382407	1
18	Screw, Housing to gearcase	—	317624	4	61	Bearing Housing	—	397087	1
19	Bearing Housing	—	397493	1	62	Screw, Retainer	18-2377	316563	4
20	O-Ring Bearing Housing	18-7130	314728	1	63	O-Ring	18-7475	332583	1
21	Shim .003	18-2229	323362	AR	64	Roller Bearing (Aft)	18-1350	379504	1
	Shim .004	18-2230	323361	AR	65	Oil Seals, Prop Shaft	18-2001	330137	2
	Shim .005	18-2231	314745	AR	66	Thrust Washer	18-4222	318841	1
22	Thrust Washer, Pinion	18-0200	327656	1	68	Propeller	—	Various	1
23	Thrust Bearing, Pinion	18-1365	387656	1	69	Spacer, Prop Nut	18-4228	315810	1
24	Drive Shaft (long)	—	394613	1	70	Nut, Propeller	18-3705	314503	1
	Drive Shaft (x-long)	—	394614	1	71	Cotter Pin, Prop Nut	18-3742	314502	1
25	Bearing, Pinion	18-1357	384195	1	72	Gear Housing Seal Kit	18-2623	396354	1
26	Nut, Pinion	18-3719	314730	1	73	Water Pump Repair Kit (w/housing)	18-3392	395062	1
27	Wear Plate	18-3346	330380	1	74	Grommet	18-2706	321008	1
28	Key, Impeller	18-3299	331107	1	75	Spacer, Shift rod	—	321122	1
29	Seal, Impeller Housing	18-7963	331353	1	76	Gasket, Impeller housing plate	18-2557	324701	1
30	Impeller	18-3059	395864	1	77	O-Ring, Drive Shaft	—	302035	1
31	Cup, Impeller	18-3346	330379	1	78	Screw, Cover to impeller	18-3135	306643	2
32	O-Ring, Drive Shaft	18-2769	332000	1	79	O-Ring, Driveshaft to crankcase	18-7158	310585	1
33	Housing, Water Pump	18-3130	395040	1					
34	Grommet, Water Tube	18-2703	314008	1					
35	Pump cover	—	321159	1					
36	Screw, Impeller housing	—	328715	4					
37	Grommet	18-2704	320943	1					
38	Bearing Housing Assembly	—	391365	1					
39	Ball, Detent	—	327345	1					
40	Spring, Detent	—	326666	1					
41	Pin, Housing	18-3765	331880	1					
42	Detent, Shifter	—	323946	1					
AR As required									

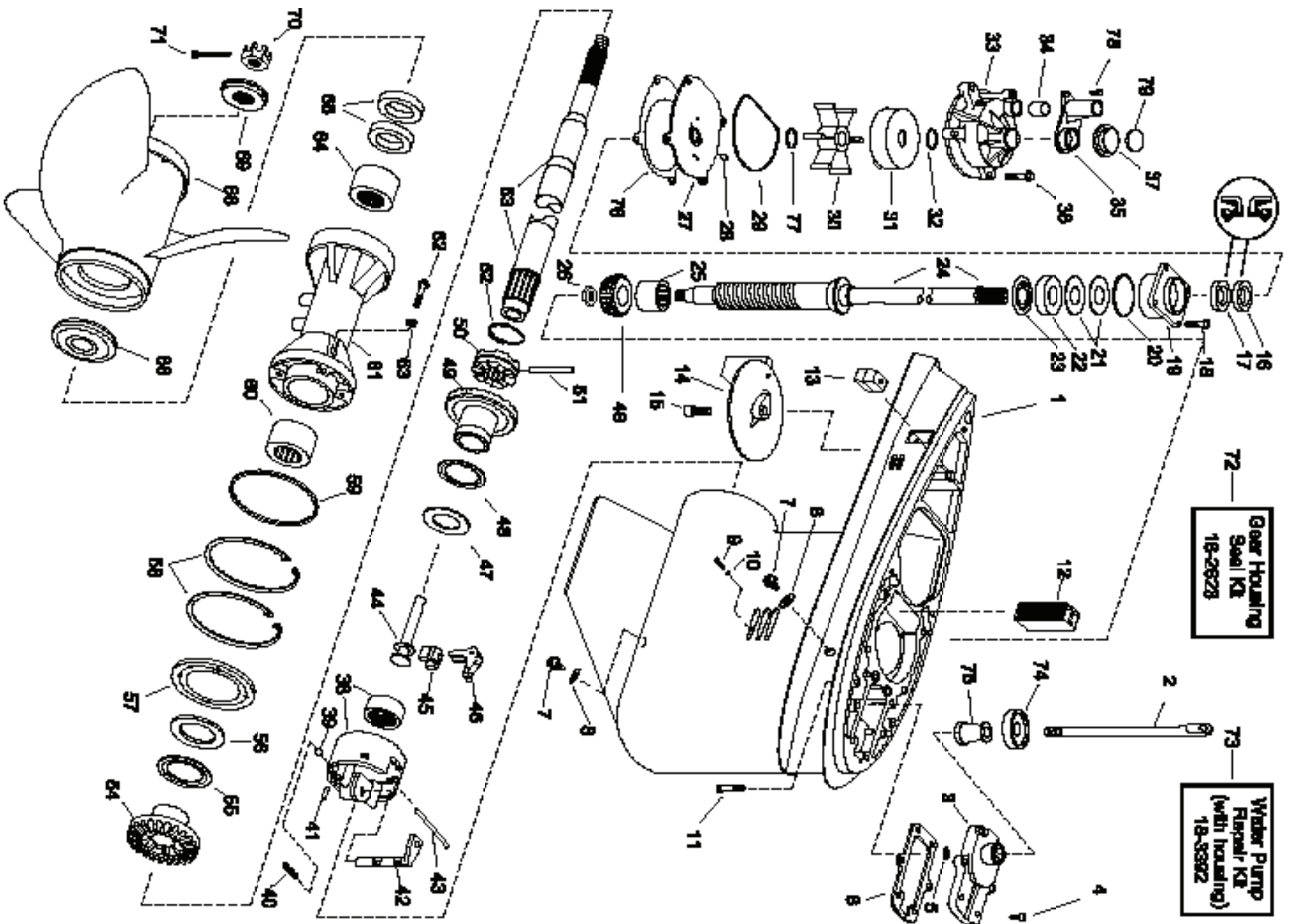

Complete Gear Housings Listed on Page 328

Figure #	Description	Part #	O.E.M. #	Qty.	Figure #	Description	Part #	O.E.M. #	Qty.
1	Housing Gearcase	—	438050	1	43	Pin, Shift Lever	—	328825	1
2	Shift Rod (long)	—	324407	1	44	Shift Shaft	18-3763	322941	1
2	Shift Rod (x-long)	—	324408	1	45	Cradler, Shifter	18-3766	334163	1
3	Cover & Shift Rod	—	435482	1	46	Shift Lever	18-3762	322938	1
4	Screw, Cover	18-3369	302325	6	47	Thrust Washer, Forward Gear	18-0199	327669	1
5	O-Ring, Shift Rod	18-7137	318372	1	48	Thrust Bearing, Forward Gear	18-1370	389042	1
6	Gasket, Shift Housing	18-0110	324670	1	49	Gear Set, Forward & Pinion	NSS	435020	1
7	Magnetic Drain Screw	18-2378	318544	2	50	Sliding Clutch	18-2216	337774	1
8	O-Rings, Plugs	18-7145	333572	2	51	Pin, Clutch Dog	18-1714	313448	1
9	Screw	—	324852	1	52	Retaining Spring	18-2399	324369	1
10	O-Ring	18-7120	307853	1	53	Propeller Shaft	18-2187	395209	1
11	Screw, Gearcase to housing	—	320741	5	54	Gear, Reverse	NSS	910994	1
12	Screen, Water intake	—	321123	1	55	Thrust Bearing, Reverse Gear	18-1366	382408	1
13	Anode	18-6024	393023	1	56	Thrust Washer, Reverse Gear	18-0195	314731	1
14	Trim Tab	—	327640	1	57	Retainer Plate/Bearing Housing	—	321174	1
15	Screw, Trim tab	—	313715	1	58	Retaining Rings	—	321171	2
16	Oil Seal, Upper	18-2061	329922	1	59	O-Ring, Bearing Housing	18-7133	305123	1
17	Oil Seal, Lower	18-2062	329923	1	60	Carrier Bearing (Fore)	18-1351	382407	1
18	Screw, Housing to gearcase	—	316534	4	61	Bearing Housing	—	397094	1
19	Bearing Housing	—	438963	1	62	Screw, Retainer	18-2377	316563	4
20	O-Ring Bearing Housing	18-7130	314728	1	63	O-Ring	18-7109	317178	1
21	Shim .003	18-2229	323362	AR	64	Roller Bearing (Aft)	18-1158	387247	1
21	Shim .004	18-2230	323361	AR	65	Oil Seals, Prop Shaft	18-2002	320862	2
21	Shim .005	18-2231	314745	AR	66	Thrust Washer	18-4223	333592	1
22	Thrust Washer, Pinion	18-0200	327656	1	68	Propeller	—	various	1
23	Thrust Bearing, Pinion	18-1365	387665	1	69	Spacer, Prop Nut	18-4231	320570	1
24	Drive Shaft (long)	see app chart	435755	1	70	Nut, Propeller	18-3708-1	398042	1
24	Drive Shaft (x-long)	see app chart	435756	1	71	Cotter Pin, Prop Nut	18-3741	306394	1
25	Bearing, Pinion	18-1117	387817	1	72	Gear Housing Seal Kit	18-2623	396353	1
26	Nut, Pinion	18-3719	314730	1	73	Water Pump Repair Kit (w/housing)	18-3392	434421	1
27	Cup & Plate Assembly	18-3346	330380	1	74	Grommet	18-2706	321008	1
28	Key, Impeller	18-3299	331107	1	75	Spacer, Shift rod	—	321122	1
29	Seal, Impeller Housing	18-7963	331353	1	76	Gasket, Impeller housing plate	18-2557	324701	1
30	Impeller	18-3059	397131	1	77	O-Ring, Drive Shaft	18-7158	310585	1
31	Cup & Plate Assembly	18-3346	330379	1	78	Screw, Cover to impeller	18-3135	306643	2
32	O-Ring, Drive Shaft	18-7158	310585	1	79	O-Ring, Driveshaft to crankcase	18-7158	310585	1
33	Housing, Water Pump	18-3130	395040	1					
34	Grommet, Water Tube	18-2703	314008	1					
35	Pump cover	—	321159	1					
36	Screw, Impeller housing	18-3136	323626	4					
37	Grommet	18-2704	320943	1					
38	Bearing Housing Assembly	—	389455	1					
39	Ball, Detent	18-1501	160084	1					
40	Spring, Detent	18-1502	911962	1					
41	Pin, Housing	18-3765	331880	1					
42	Detent, Shifter	—	323946	1					

AR As required



18-4840^②
COMPLETE LOWER GEARCASE ASSEMBLIES
 Replaces: 435277
 Fits: 40/48/50hp w/20" Shaft (1989-92)



18-4841^②
COMPLETE LOWER GEARCASE ASSEMBLIES
 Replaces: 435276
 Fits: 40/48/50hp w/15" Shaft (1989-92)



18-4843^②
COMPLETE LOWER GEARCASE ASSEMBLIES
 Replaces: 435279
 Fits: 40/48/50hp w/15" Shaft (1993 and Up)

PKG. OF 5



18-2377
18-2377-9^①
RETAINER SCREW
 Replaces: 316563

PKG. OF 4



18-2379
18-2379-9^①
LOWER UNIT CARRIER SCREW
 Replaces: 320041



18-4826
GEARCASE TO HOUSING SCREW
 Replaces: 331999

PKG. OF 5



18-4253-9^①
18-42531-9^①
 (PKG. OF 50)
DRAIN SCREW O-RING
 Replaces: 336982
 Used w/ **18-1236** Drain Screw

PKG. OF 5



18-4248
18-4248-9^①
18-42481-9^①
 (PKG. OF 50)
DRAIN/FILL PLUG WASHER
 (Plastic)
 Replaces: 311598
 Used with **18-2387** Drain Screw

PKG. OF 2



18-2945
18-2945-9^①
18-29451-9^①
 (PKG. OF 50)
DRAIN SCREW GASKET
 Replaces: 307552



18-1236
DRAIN SCREW
 Replaces: 309243
 For: 40-50 HP (1989-97)
 Cobra Drives



18-2387
18-23871-9^①
 (PKG. OF 50)
LOWER UNIT DRAIN/FILL SCREW
 Slot Head



18-4255
E-TEC DRAIN SCREW
 Replaces: 307551
 Allan Head



18-2378
18-23781-9^①
 (PKG. OF 50)
MAGNETIC DRAIN SCREW
 Slot Head

^① Priced per package

^② All gearcase assemblies pictured above are primed only. Be prepared to paint the gearcase to match your customer's engine.

 <p>18-4249 E-TEC DRAIN SCREW WITH MAGNET Replaces: 318544 Allan Head</p>	 <p>18-3708-1 PROP NUT & KEEPER Replaces: 398042</p>	<p>PKG. OF 5</p>  <p>PROP NUTS</p> <table border="1"> <thead> <tr> <th>PART #</th> <th>O.E. #</th> </tr> </thead> <tbody> <tr> <td>18-3705②</td> <td>314503</td> </tr> <tr> <td>18-3706②</td> <td>318971</td> </tr> <tr> <td>18-3707②</td> <td>319891</td> </tr> </tbody> </table>	PART #	O.E. #	18-3705 ②	314503	18-3706 ②	318971	18-3707 ②	319891	<p>PKG. OF 10</p>  <p>COTTER PINS</p> <table border="1"> <thead> <tr> <th>PART #</th> <th>O.E. #</th> <th>DIMEN.</th> </tr> </thead> <tbody> <tr> <td>18-3735②</td> <td>5030087</td> <td>5/32" X 1 3/8"</td> </tr> <tr> <td>18-3740②</td> <td>302804</td> <td>3/32" X 1"</td> </tr> <tr> <td>18-3741②</td> <td>309955</td> <td>1/8" X 1 3/4"</td> </tr> <tr> <td>18-3742②</td> <td>314502</td> <td>1/8" X 1 1/4"</td> </tr> <tr> <td>18-3743②</td> <td>320785</td> <td>1/8" X 3/4"</td> </tr> <tr> <td>18-3744②</td> <td>552906</td> <td>3/32" X 3/4"</td> </tr> </tbody> </table>	PART #	O.E. #	DIMEN.	18-3735 ②	5030087	5/32" X 1 3/8"	18-3740 ②	302804	3/32" X 1"	18-3741 ②	309955	1/8" X 1 3/4"	18-3742 ②	314502	1/8" X 1 1/4"	18-3743 ②	320785	1/8" X 3/4"	18-3744 ②	552906	3/32" X 3/4"							
PART #	O.E. #																																						
18-3705 ②	314503																																						
18-3706 ②	318971																																						
18-3707 ②	319891																																						
PART #	O.E. #	DIMEN.																																					
18-3735 ②	5030087	5/32" X 1 3/8"																																					
18-3740 ②	302804	3/32" X 1"																																					
18-3741 ②	309955	1/8" X 1 3/4"																																					
18-3742 ②	314502	1/8" X 1 1/4"																																					
18-3743 ②	320785	1/8" X 3/4"																																					
18-3744 ②	552906	3/32" X 3/4"																																					
<p>③ 18-3715D </p>  <p>18-3715 PROP NUT KIT Replaces: 175266 — CONTAINS —</p> <table border="1"> <thead> <tr> <th>Part #</th> <th>O.E. #</th> <th>Description</th> </tr> </thead> <tbody> <tr> <td>18-3708-1</td> <td>398042</td> <td>Prop Nut/Keeper</td> </tr> <tr> <td>18-3741</td> <td>309955</td> <td>Cotter Pin</td> </tr> <tr> <td>18-4231</td> <td>320570</td> <td>Prop Spacer</td> </tr> </tbody> </table>	Part #	O.E. #	Description	18-3708-1	398042	Prop Nut/Keeper	18-3741	309955	Cotter Pin	18-4231	320570	Prop Spacer	<p>③ 18-3716D </p>  <p>18-3716 PROP NUT KIT Replaces: 175267 — CONTAINS —</p> <table border="1"> <thead> <tr> <th>Part #</th> <th>O.E.#</th> <th>Description</th> </tr> </thead> <tbody> <tr> <td>18-3705</td> <td>314503</td> <td>Prop Nut</td> </tr> <tr> <td>18-3742</td> <td>314502</td> <td>Cotter Pin</td> </tr> <tr> <td>18-4228</td> <td>315810</td> <td>Prop Spacer</td> </tr> </tbody> </table>	Part #	O.E.#	Description	18-3705	314503	Prop Nut	18-3742	314502	Cotter Pin	18-4228	315810	Prop Spacer	<p>③ 18-3717D </p>  <p>18-3717 PROP NUT KIT Replaces: 175268 — CONTAINS —</p> <table border="1"> <thead> <tr> <th>Part #</th> <th>O.E. #</th> <th>Description</th> </tr> </thead> <tbody> <tr> <td>18-3707</td> <td>319891</td> <td>Prop Nut</td> </tr> <tr> <td>18-3743</td> <td>320785</td> <td>Cotter Pin</td> </tr> <tr> <td>18-4232</td> <td>323943</td> <td>Prop Spacer</td> </tr> </tbody> </table>	Part #	O.E. #	Description	18-3707	319891	Prop Nut	18-3743	320785	Cotter Pin	18-4232	323943	Prop Spacer	 <p>18-3753 PROP NUT KIT Replaces: 5005034 Fits: 40-130 (2001 & Up)</p>
Part #	O.E. #	Description																																					
18-3708-1	398042	Prop Nut/Keeper																																					
18-3741	309955	Cotter Pin																																					
18-4231	320570	Prop Spacer																																					
Part #	O.E.#	Description																																					
18-3705	314503	Prop Nut																																					
18-3742	314502	Cotter Pin																																					
18-4228	315810	Prop Spacer																																					
Part #	O.E. #	Description																																					
18-3707	319891	Prop Nut																																					
18-3743	320785	Cotter Pin																																					
18-4232	323943	Prop Spacer																																					
 <p>18-3768 COVER NUT Replaces: 911751 For: Cobra drives: 115 (1994-97), 232 (1987-90), 252 (1986), 262 (1989), 302 (1987)</p>	 <p>18-4222 THRUST WASHER Replaces: 318841, 127084</p>	 <p>18-4223 THRUST WASHER Replaces: 333592</p>	 <p>18-4228 PROP SPACER Replaces: 315810</p>																																				
 <p>18-4229 THRUST WASHER Replaces: 319890</p>	 <p>18-4230 THRUST WASHER Replaces: 320305</p>	 <p>18-4231 PROP SPACER Replaces: 320570</p>	 <p>18-4232 PROP SPACER Replaces: 323943</p>																																				

APPLICATION ON NEXT PAGE

- ① Priced per package ② This product is priced per piece. To order priced per package, please add -9 to the part number.
③ Items ending in "D" are Display Packaged - Regular number is Non-Display

JOHNSON/EVINRUDE

HP	Year	Spacer Before Prop	Washer After Prop	Prop Nut	Cotter Pin	Prop Nut Kit
9.9/15	1974-75	—	—	18-3706	18-3740	—
9.9/15	1976-99	—	—	18-3706	18-3744	—
20	1984-90	18-4229	18-4232	18-3707	18-3743	18-3717
20/30/35	1991-99	—	18-4232	18-3707	18-3743	18-3717
25 ⑥	1991	—	18-4232	18-3707	18-3743	18-3717
25 ⑦	1991	18-4232	18-4228	18-3705	18-3742	18-3716
25 ⑧	1992	—	18-4232	18-3707	18-3743	18-3717
25/30	1984-90	18-4229	18-4232	18-3707	18-3743	18-3717
35	1976-90	18-4229	18-4232	18-3707	18-3743	18-3717
40 ① ④	1984-99	18-4230	18-4228	18-3705	18-3742	18-3716
40 Comm	1996-97	18-4222	18-4228	18-3705	18-3742	18-3716
40 Comm	1998-99	—	18-4228	18-3705	18-3742	18-3716
45 Comm ②	1986-97	—	18-4228	18-3705	18-3742	18-3716
48 ①	1987-96	18-4230	18-4228	18-3705	18-3742	18-3716
50/60 TTL	1996-98	18-4222	18-4228	18-3705	18-3742	18-3716
50 ②	1971-74	18-4222	18-4228	18-3705	18-3742	18-3716
50 ① ④	1975-99	18-4230	18-4228	18-3705	18-3742	18-3716
50 EL&DT	1996-98	—	18-4228	18-3705	18-3742	18-3716
50 Comm ②	1977-79	18-4222	18-4228	18-3705	18-3742	18-3716
55	1968-69	18-4222	18-4228	18-3705	18-3742	18-3716
55 ①	1976-79	18-4230	18-4228	18-3705	18-3742	18-3716
55 Comm ②	1980-97	18-4222	18-4228	18-3705	18-3742	18-3716
55 Comm	1998-99	—	18-4228	18-3705	18-3742	18-3716
60/70 ④	1996-99	—	18-4228	18-3705	18-3742	18-3716
60	1970-71, 1986-95	18-4222	18-4228	18-3705	18-3742	18-3716
60 ①	1980-85	18-4230	18-4228	18-3705	18-3742	18-3716
65	1972-73	18-4222	18-4228	18-3705	18-3742	18-3716
65 Comm	1984-95	18-4222	18-4228	18-3705	18-3742	18-3716
65 Comm	1996-99	—	18-4228	18-3705	18-3742	18-3716
70	1974-95	18-4222	18-4228	18-3705	18-3742	18-3716
75 ②	1975-84	18-4222	18-4228	18-3705	18-3742	18-3716
75 ①	1975-85	18-4230	18-4228	18-3705	18-3742	18-3716
Formula E	1986-90	18-4230	18-4228	18-3705	18-3742	18-3716
Sprint	1986-90	18-4230	18-4228	18-3705	18-3742	18-3716
85	1969-80, 1995	18-4222	18-4228	18-3705	18-3742	18-3716
88/90	1981-95	18-4222	18-4228	18-3705	18-3742	18-3716
88	1996	—	18-4228	18-3705	18-3742	18-3716
90 ① ④	1996-99	—	18-4228	18-3705	18-3742	18-3716
90 ②	1996	—	18-4231	18-3708-1	—	—
90 V-4 ④	1997-99	—	18-4228	18-3705	18-3742	18-3716
90 V-4 ② ④	1997	18-4223	18-4231	18-3708-1	—	—
90 FSX/ FPX ④	1998-99	18-4223	18-4231	18-3708-1	—	—
100	1979-80	18-4222	18-4228	18-3705	18-3742	18-3716
100 ⑨	1988-94	18-4222	18-4228	18-3705	18-3742	18-3716
100 ⑩	1992	—	18-4231	18-3708-1	—	—
100 Comm ④	1996, 1998	—	18-4228	18-3705	18-3742	18-3716
100 Comm	1995-97, 1999	18-4223	18-4231	18-3708-1	—	—
100 Comm ③	1984-90	18-4223	18-4231	18-3708-1	18-3741	18-3715
110	1986-89	18-4222	18-4228	18-3705	18-3742	18-3716
112	1996	—	18-4228	18-3705	18-3742	18-3716
115	1973-94	18-4222	18-4228	18-3705	18-3742	18-3716
115 ① ④	1996-99	—	18-4228	18-3705	18-3742	18-3716
115 ②	1996	—	18-4231	18-3708-1	—	—
115 V-4 ④	1997-99	—	18-4228	18-3705	18-3742	18-3716
115 V-4 ② ④	1997	18-4223	18-4231	18-3708-1	—	—
115 FSX/ FPX ④	1998-99	18-4223	18-4231	18-3708-1	—	—
120 ③	1985	18-4223	18-4231	18-3708-1	18-3741	18-3715

APPLICATION CONTINUED ON NEXT PAGE

- ① Models equipped with small gearcase
- ② Models equipped with large gearcase
- ③ Models equipped with V-6 gearcase
- ④ For 3-Blade propeller only
- ⑤ Use 18-4222 for 4-Blade propeller

- ⑥ All models except DR, DE & DT
- ⑦ Models DR, DE & DT only
- ⑧ Except models RSU, RSLU, RWENB, RWLENB
- ⑨ Except 1992 models WTLNE, WTXNENE
- ⑩ Models WTLNE, WTXNENE

- ❶ 1992 ES models only
- ❷ Except 1992 ESX models
- ❸ 1992 TL models only
- ❹ 1992 CX, TX models only

JOHNSON/EVINRUDE						
HP	Year	Spacer Before Prop	Washer After Prop	Prop Nut	Cotter Pin	Prop Nut Kit
120	1986-94	18-4222	18-4228	18-3705	18-3742	18-3716
125 ①	1971-94	18-4222	18-4228	18-3705	18-3742	18-3716
125 ②	1992	—	18-4231	18-3708-1	—	—
125 Comm	1991	—	18-4231	18-3708-1	18-3741	18-3715
125 Comm	1992-96	18-4223	18-4231	18-3708-1	—	—
130	1995-99	18-4223	18-4231	18-3708-1	—	—
135	1973-76	18-4222	18-4228	18-3705	18-3742	18-3716
140	1977-84	18-4222	18-4228	18-3705	18-3742	18-3716
140 ③	1985	18-4223	18-4231	18-3708-1	18-3741	18-3715
140 ③	1986-94	18-4222	18-4228	18-3705	18-3742	18-3716
140 ③	1990	18-4223	18-4231	18-3708-1	18-3741	18-3715
140 ④	1992	—	18-4231	18-3708-1	—	—
150	1978-90	18-4223	18-4231	18-3708-1	18-3741	18-3715
150	1991-95	—	18-4231	18-3708-1	18-3741	18-3715
150 ④	1996-99	18-4223	18-4231	18-3708-1	—	—
155 Comm	1984-90	18-4223	18-4231	18-3708-1	18-3741	18-3715
155 Comm	1991-95	—	18-4231	18-3708-1	18-3741	18-3715
175	1977-90	18-4223	18-4231	18-3708-1	18-3741	18-3715
175	1992	—	18-4231	18-3708-1	—	—
175 ④	1993-99	18-4223	18-4231	18-3708-1	—	—
185	1984-85	18-4223	18-4231	18-3708-1	18-3741	18-3715
185 Comm ④	1991-95	—	18-4231	18-3708-1	18-3741	18-3715
200	1976-90	18-4223	18-4231	18-3708-1	18-3741	18-3715
200/225 ④	1991-95	—	18-4231	18-3708-1	18-3741	18-3715
200/225 ④	1996-99	18-4223	18-4231	18-3708-1	—	—
225	1986-90	18-4223	18-4231	18-3708-1	18-3741	18-3715
235	1978-85	18-4223	18-4231	18-3708-1	18-3741	18-3715
250/300	1991	18-4223 ⑤	18-4231	18-3708-1	18-3741	18-3715
250/300	1992	—	18-4231	18-3708-1	—	—
250/300 ④	1993-95	18-4223	18-4231	18-3708-1	—	—
250	1996-99	18-4223	18-4231	18-3708-1	—	—
2.6L	1984-85	18-4223	18-4231	18-3708-1	18-3741	18-3715
275	1986	18-4223	18-4231	18-3708-1	18-3741	18-3715
3.6L	1986-90	18-4223	18-4231	18-3708-1	18-3741	18-3715

OMC SEA DRIVE

V4	1982-90	18-4222	18-4228	18-3708-1	18-3742	18-3715
V6	1982-90	18-4223	18-4231	18-3708-1	18-3741	18-3715
V8	1987, 1989-90	18-4223	18-4231	—	—	—

- ① Models equipped with small gearcase
- ② Models equipped with large gearcase
- ③ Models equipped with V-6 gearcase
- ④ For 3-Blade propeller only
- ⑤ Use 18-4222 for 4-Blade propeller

- ⑥ All models except DR, DE & DT
- ⑦ Models DR, DE & DT only
- ⑧ Except models RSU, RSLU, RWENB, RWLENB
- ⑨ Except 1992 models WTLNE, WTXNENE
- ⑩ Models WTLNE, WTXNENE

- ① 1992 ES models only
- ② Except 1992 ESX models
- ③ 1992 TL models only
- ④ 1992 CX, TX models only

 <p>18-8304 OIL SEAL Replaces: 321830</p>	 <p>18-0195 THRUST WASHER Reverse & Forward Gear Replaces: 314731 For: 45-60 HP - 2 Cyl, 3 Cyl, V-4 & V-6</p>	 <p>18-0197 THRUST WASHER Forward Gear Replaces: 333725 For: 40-55 HP - 1989-1995</p>	 <p>18-0198 THRUST WASHER Forward Gear Replaces: 324766 For: 3 Cyl, V-4 & V-6</p>
 <p>18-0200 THRUST WASHER Drive Shaft Replaces: 327656 For: V-4 & V-6</p>	 <p>18-0201 THRUST WASHER Drive Shaft Replaces: 333771 For: 40-60 HP - 1990-1995</p>	 <p>18-1117 PINION BEARING Replaces: 387817</p>	 <p>18-1154 BALL BEARING Replaces: 377139</p>



18-1158
CARRIER BEARING
 Replaces: 387247



18-1750
COMPLETE BEARING HOUSING
 For: Cobra Drives & V6



18-1161
TAPERED ROLLER BEARING
 Replaces: 983891



18-1299
LOWER MAIN BEARING
 Replaces: 433503
 For: V4 & V6 60° engines



18-1344
NEEDLE BEARING
 Ref. # J-1812
 Fits: Driveshaft bearing cup 18-4807
 (OE# 439476)



18-1350
NEEDLE BEARING
(CARRIER)
 Replaces: 379504



18-1351
NEEDLE BEARING
(CARRIER)
 Replaces: 382407



18-1354
NEEDLE BEARING
 Replaces: 386764



18-1355
NEEDLE BEARING
 Replaces: 386765



18-1356
NEEDLE BEARING
(PINION)
 Replaces: 382343



18-1357
NEEDLE BEARING
(PINION)
 Replaces: 384195



18-1363
THRUST BEARING
 Replaces: 397537

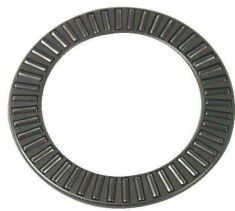

18-1364
THRUST BEARING
 Replaces: 397538



18-1365
THRUST BEARING
 Replaces: 387656



18-1366
THRUST BEARING
 Replaces: 382408

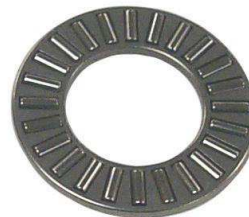

18-1367
THRUST BEARING
 Replaces: 385068



18-1368
THRUST BEARING
 Replaces: 398901



18-1369
THRUST BEARING
 Replaces: 432264



18-1370
THRUST FORWARD
BEARING
 Replaces: 389042

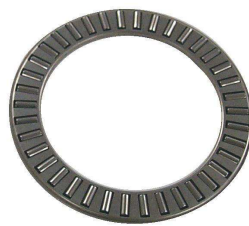

18-1371
THRUST FORWARD
BEARING
 Replaces: 385043

APPLICATION BEGINS ON NEXT PAGE

HP	Year	Drive Shaft Bearing	Pinion Gear Bearing	Fore Carrier Bearing	Aft Carrier Bearing	Fwd. Gear Thrust Bearing	Rev Gear Thrust Bearing	Fore Propshaft Bearing	Aft. Propshaft Bearing
25D	1989-95	18-1368	18-1356	18-1354	18-1355	18-1364	18-1363	18-1369	18-1351
35	1987	—	—	18-1354	18-1355	—	—	—	—
40	1984-88	—	—	18-1354	18-1355	—	—	—	—
40	1989-Up	18-1368	18-1356	18-1354	18-1355	18-1364	18-1363	18-1369	18-1351
45 Comm	1985-Up	—	18-1367	18-1356	18-1351	18-1350	18-1371	18-1366	—
48	1987-88	—	—	18-1354	18-1355	—	—	—	—
48	1989-96	18-1368	18-1356	18-1354	18-1355	18-1364	18-1363	18-1369	18-1351
50	1973-74	18-1367	18-1356	18-1351	18-1350	18-1366	18-1366	—	—
50	1975	—	—	18-1354	18-1355	—	—	—	—
50	1979-88	—	—	18-1354	18-1355	—	—	—	—
50	1989-Up	18-1368	18-1356	18-1354	18-1355	18-1364	18-1363	18-1369	18-1351
50 ①	1995-Up	18-1367	18-1356	18-1351	18-1350	18-1371	18-1366	—	—
55	1976-81	—	—	18-1354	18-1355	—	—	—	—
55 ②	1980-82	18-1367	18-1356	18-1351	18-1350	18-1366	18-1366	—	—
55 Comm	1983-Up	—	18-1367	18-1356	18-1351	18-1350	18-1371	18-1366	—
60 ②	1980-81	18-1367	18-1356	18-1351	18-1350	18-1366	18-1366	—	—
60	1980-85	—	—	18-1354	18-1355	—	—	—	—
60 ③	1986-87	—	—	18-1354	18-1355	—	—	—	—
60 ④	1986-97	18-1367	18-1356	18-1351	18-1350	18-1371	18-1366	—	—
65	1973	18-1367	18-1356	18-1351	18-1350	18-1371	18-1366	—	—
65 Comm	1984-97	—	18-1367	18-1356	18-1351	18-1350	18-1371	18-1366	—
70 ④	1974-97	18-1367	18-1356	18-1351	18-1350	18-1371	18-1366	—	—
70 ③	1979-85	—	—	18-1354	18-1355	—	—	—	—
75 ④	1975-88	18-1367	18-1356	18-1351	18-1350	18-1371	18-1366	—	—
75 ③	1979-87	—	—	18-1354	18-1355	—	—	—	—
85	1973-80	18-1365	18-1357	18-1351	18-1350	18-1371	18-1366	—	—
85	1991-95	18-1365	18-1357	18-1351	18-1350	18-1371	18-1366	—	—
88	1987-96	18-1365	18-1357	18-1351	18-1350	18-1371	18-1366	—	—
90	1981-97	18-1365	18-1357	18-1351	18-1350	18-1371	18-1366	—	—
100	1979-80	18-1365	18-1357	18-1351	18-1350	18-1371	18-1366	—	—
100	1990-94	18-1365	18-1357	18-1351	18-1350	18-1371	18-1366	—	—
100 Comm	1984-90	—	18-1365	18-1117	18-1351	18-1158	18-1370	18-1366	—
100 Comm ⑧	1989-90	—	18-1365	18-1357	18-1351	18-1350	18-1371	18-1366	—
100 Comm	1991-93	—	18-1365	18-1117	18-1351	—	18-1370	18-1366	—
110	1986-89	18-1365	18-1357	18-1351	18-1350	18-1371	18-1366	—	—
112	1994-95	18-1365	18-1357	18-1351	18-1350	18-1371	18-1366	—	—
115	1973-85	18-1365	18-1357	18-1351	18-1350	18-1371	18-1366	—	—
115	1990-95	18-1365	18-1357	18-1351	18-1350	18-1371	18-1366	—	—
120	1985	18-1365	18-1117	18-1351	18-1158	18-1370	18-1366	—	—
120	1986-92	18-1365	18-1357	18-1351	18-1350	18-1371	18-1366	—	—
125 Comm ⑤	1989-90	—	18-1365	18-1117	18-1351	18-1158	18-1370	18-1366	—
125 Comm ⑥	1989-90	—	18-1365	18-1357	18-1351	18-1350	18-1371	18-1366	—
125 Comm	1991-94	—	18-1365	18-1117	18-1351	—	18-1370	18-1366	—
125	1992	18-1365	18-1357	18-1351	18-1350	18-1371	18-1366	—	—
135	1973-76	18-1365	18-1357	18-1351	18-1350	18-1371	18-1366	—	—
140	1977-84	18-1365	18-1357	18-1351	18-1350	18-1371	18-1366	—	—
140	1985	18-1365	18-1117	18-1351	18-1158	18-1370	18-1366	—	—
140	1986-92	18-1365	18-1357	18-1351	18-1350	18-1371	18-1366	—	—
140 TX	1988-90	18-1365	18-1117	18-1351	18-1158	18-1370	18-1366	—	—
140 TX	1991-92	18-1365	18-1117	18-1351	—	18-1370	18-1366	—	—
150	1978-90	18-1365	18-1117	18-1351	18-1158	18-1370	18-1366	—	—
150	1991-95	18-1365	18-1117	18-1351	—	18-1370	18-1366	—	—
150 Comm	1993-95	—	18-1365	18-1117	18-1351	—	18-1370	18-1366	—
155 Comm	1984-90	—	18-1365	—	18-1351	18-1158	—	18-1366	—
155 Comm ⑤	1989-90	18-1365	18-1117	18-1351	18-1158	18-1370	18-1366	—	—
155 Comm ⑦	1989-90	18-1365	18-1117	18-1351	18-1158	18-1370	18-1366	—	—
175	1977	18-1365	18-1117	18-1351	18-1158	—	18-1366	—	—
175	1978-90	18-1365	18-1117	18-1351	18-1158	18-1370	18-1366	—	—
175	1991-97	18-1365	18-1117	18-1351	—	18-1370	18-1366	—	—
185	1984-85	18-1365	18-1117	18-1351	18-1158	18-1370	18-1366	—	—
185	1990	18-1365	18-1117	18-1351	18-1158	18-1370	18-1366	—	—
185	1992-94	18-1365	18-1117	18-1351	—	18-1370	18-1366	—	—
200	1976-77	18-1365	18-1117	18-1351	18-1158	—	18-1366	—	—
200	1978-90	18-1365	18-1117	18-1351	18-1158	18-1370	18-1366	—	—
200	1991-97	18-1365	18-1117	18-1351	—	18-1370	18-1366	—	—
200 Comm	1990-91	—	18-1365	18-1117	18-1351	18-1158	18-1370	18-1366	—
225	1986-90	18-1365	18-1117	18-1351	18-1158	18-1370	18-1366	—	—
225	1991-97	18-1365	18-1117	18-1351	—	18-1370	18-1366	—	—
235	1978-85	18-1365	18-1117	18-1351	18-1158	18-1370	18-1366	—	—

① 3 Cyl. Models

② Rope Start Models

③ 15" Transom Models

④ 20" Transom Models

⑤ WTP Models

⑥ ESX Models

⑦ WTA Models Only

⑧ Models with "S" Prefix Only

OUTBOARD SHAFTS



18-1723
LOWER DRIVE SHAFT
 Replaces: 346004
 For: V4 60" includes: E100, E115, E75, E 90, J115 & J90



18-2277
LOWER DRIVE SHAFT
 Replaces: 335722



18-2279
LOWER DRIVE SHAFT
 Replaces: 335679



18-9219
LOWER DRIVE SHAFT
 Replaces: 335677



18-1722
DRIVE SHAFT
 Replaces: 438399
 For: 20" Models, 40-50HP (1997-99)



18-1721
DRIVE SHAFT
 Replaces: 433067
 For: 20" Models, 40-50(1989-92)

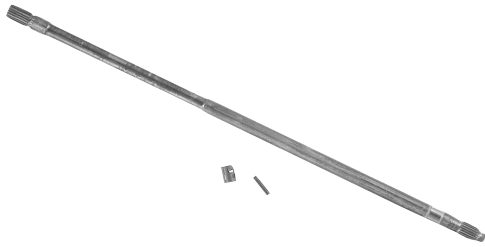

18-2325
UPPER DRIVE SHAFT ASSEMBLY
 Replaces: 435760



18-2326
UPPER DRIVE SHAFT ASSEMBLY
 Replaces: 436232



18-2327
UPPER DRIVE SHAFT ASSEMBLY
 Replaces: 436234

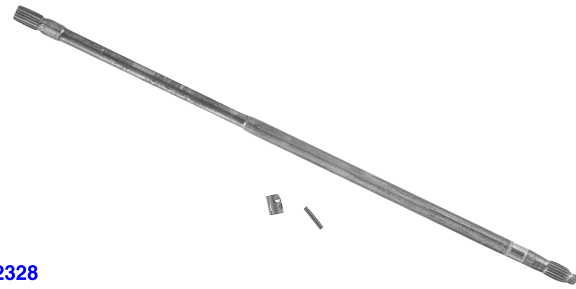

18-2328
UPPER DRIVE SHAFT ASSEMBLY
 Replaces: 435761



18-2330
UPPER DRIVE SHAFT ASSEMBLY
 (Extra Long)
 Replaces: 436235



18-2093
SEAL
 Replaces: 319664, 333096, 398051
 For: 20 - 35 HP(1977-95) seal for prop-shaft **18-2026**, driveshaft **18-2033**, upper crankcase **18-8351**

APPLICATION BEGINS ON NEXT PAGE

HP	Year	Lower Drive Shaft	Upper Drive Shaft	Upper Drive Shaft (Extra Long)	HP	Year	Lower Drive Shaft	Upper Drive Shaft	Upper Drive Shaft (Extra Long)
85 TTL	1991	18-2277	—	—	140 TX	1990-91	18-9219	—	—
85 TTL	1992-95	18-2277	18-2326	—	140 TL	1991-94	18-2277	18-2326	—
88	1991	18-2277	—	—	140 TX	1992-94	18-9219	—	—
88	1992-96	18-2277	18-2326	—	150	1990	18-9219	—	—
90	1991	18-2277	—	—	150	1991	18-9219	—	—
90	1992-97	18-2277	18-2326	—	150	1992-97	18-9219	18-2327	18-2330
90 ① ②	1995-96	—	18-2327	—	150 Comm	1993-95	18-9219	18-2327	18-2330
90 ② ③	1995-96	18-9219	—	18-2330	155 Comm	1990	18-2279③	—	—
90 ②	1997	18-2277	18-2326	—	155 Comm ⑤	1990	18-9219	—	—
100	1991	18-2277	—	—	155 Comm	1991	18-9219	—	—
100	1992-94	18-2277	18-2326	—	155 Comm	1992	18-9219	18-2326	—
100 Comm	1991	18-9219	—	—	175	1990	18-9219	—	—
100 Comm	1992-97	18-9219	18-2326	—	175	1991	18-9219	—	—
112	1994-96	18-2277	18-2326	—	175	1992-97	18-9219	18-2327	18-2330
115	1991	18-2277	—	—	185	1990	18-9219	—	—
115	1992-97	18-2277	18-2326	—	185	1991	18-9219	—	—
115 ① ②	1995-96	—	18-2327	—	185	1992-94	18-9219	18-2326	—
115 ② ③	1995-96	18-9219	—	18-2330	200	1990	18-9219	—	—
115 ②	1997	18-2277	18-2326	—	200	1991	18-9219	—	—
120	1991-93	18-2277	—	—	200	1992-97	18-9219	18-2326	—
120 ④	1993	18-9219	—	—	200 Comm	1990	18-9219	—	—
120 TL	1994	18-2277	18-2326	—	225	1990	18-9219	—	—
120 TX	1994	18-9219	—	—	225	1991	18-9219	—	—
125 Comm	1991-95	18-9219	18-2326	—	225	1992-97	18-9219	18-2326	—
125	1992-93	18-2277	—	—	250	1991-95	18-2279	—	—
125 ④	1993	18-9219	—	—	250	1997	18-2279	—	—
125	1994	18-2277	18-2326	—	300	1990	18-2279	—	—
130	1995-97	18-9219	18-2326	—	300	1991-95	18-2279	—	—

① 20" Models ② 60 Degree V Models ③ 25" Models ④ F Suffix Only ⑤ WTP Models Only

**18-1725
PROP SHAFT**

Replaces: 436834
For: V4 60HP



**18-2187
PROP SHAFT**

Replaces: 395209, 391472



**18-2250
PROP SHAFT**

Replaces: 387879



**18-2251
PROP SHAFT**

Replaces: 435022, 433017, 436740



**18-2252
PROP SHAFT**

Replaces: 387818, 436888



**18-2355
PROP SHAFT**

Replaces: 386659
For: 35, 40, 48, 50, 55, 60, 70, 75 HP 2 & 3 cyl. outboards (1975-1987)



**18-2288
PROP SHAFT**

Replaces: 397541, 439138



PROP SHAFT APPLICATION BEGINS ON PAGE 338



18-1287
FORWARD GEAR & BUSHING
Replaces: 392475
For: 25-35HP (1975-88)



18-1291
GEAR SET
For: Commercial V4 gearcases
—CONTAINS—

Part #	Desc.	O.E.#
NSS	Forward Gear	435123
NSS	Reverse Gear	336574
18-2216	Clutch	337774



18-1292
GEAR SET
For: Late model V-6 150-225 H.P. with large reverse gear
—CONTAINS—

Part #	Desc.	O.E.#
NSS	Forward Gear	5004216
NSS	Reverse Gear	336561



18-1293
GEAR SET
For: 20HP (1984-98), 25HP(1985-02),
30HP (1984-02) 35HP (1984-01)
—CONTAINS—

Part #	Desc.	O.E.#
18-1287	Forward Gear	392475
18-1289	Reverse Gear	327655
18-1288	Pinion	328313
18-1290	Clutch	337020



18-1288
PINION GEAR
Replaces: 328313
For: 25-35HP (1984-96)



18-2208
REVERSE GEAR
Replaces: 318304



18-2209
SLIDING CLUTCH
Replaces: 318303



18-2216
SLIDING CLUTCH
Replaces: 337772, 337774, 334516,
336562, 910995



18-2217
GEAR SET
—CONTAINS—

Part #	Desc.	O.E.#
NSS	Forward Gear	435020
NSS	Reverse Gear	910994
18-2216	Sliding Clutch	337772



18-2218
FORWARD GEAR SET
Replaces: 434063, 989966,
985050, 436746
Includes: Forward & Pinion Gears



18-2219
REVERSE GEAR
Replaces: 333077, 317838, 340490



18-2220
SLIDING CLUTCH
Replaces: 323664, 320630



18-2221
GEAR SET
—CONTAINS—

Part #	Desc.	O.E.#
18-2218	Forward Gear	434063
18-2219	Reverse Gear	333077
18-2220	Sliding Clutch	323664



18-2287
CLUTCH DOG
Replaces: 319895



18-2308
SLIDING CLUTCH
Replaces: 332491



**18-1289
REVERSE GEAR**
Replaces: 327655
For: 25-35HP (1984-96)



**18-2309
REVERSE GEAR**
Replaces: 332489



**18-2290
GEAR SET**
—CONTAINS—

Part #	Desc.	O.E.#
NSS	Forward Gear Set	435020, 434026, 983141, 391289
NSS	Reverse Gear	336561
18-2216	Sliding Clutch	337774, 334516, 336562, 910795, 337772



**18-1290
CLUTCH DOG**
Replaces: 337020
For: 25-35HP (1992-98)



**18-2310
FORWARD GEAR SET**
Replaces: 397627
Includes: Forward & Pinion Gears

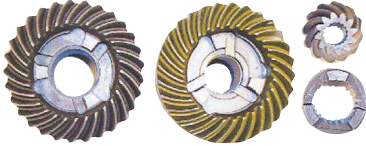

**18-2315
GEAR SET**
—CONTAINS—

Part #	Desc.	O.E.#
18-2310	Forward Gear Set	397627
18-2309	Reverse Gear	332489
18-2308	Sliding Clutch	332491



**18-1729
COVER & BUSHING
ASSEMBLY**
Replaces: 434588
For: 40HP (1993-02), 48HP (1993-96), 50HP (1993-02)



**18-1500
INTAKE WATER SCREEN**
Replaces: 337778
For: 100, 120, 125, 140, 150, 175, 200, 225 (1993) (OMC Cobra & V-6)



**18-79989
TRAILERING STICKS**
Fits: Most outboards over 150hp with three ram intrigrel tilt/trim.



**18-1343
BEARING CARRIER
RETAINING TAB**
Replaces: 333957
For: 100, 120, 125, 140, 150, 175, 200, 225, (1988-92) (Cobra Drives)



**18-1712
BEARING RETAINER**
Replaces: 980014
For: 100, 120, 140, 165, 175, 190, 225, 235 (1968-77)



**18-4807
DRIVESHAFT BEARING
RETAINER CAP**
Replaces: 439476
To replace bearing use **18-1344**



**18-3766
SHIFT CRADLE**
Replaces: 334163
For: V-4/V-6, Cobra, Stringer



**18-3765
HOUSING PIN**
Replaces: 331880
For: **18-3767** bearing housing



**18-71102
CONTROL BOX REPAIR KIT**
For: OMC 397272 + 390610

PKG. OF 2



**18-2243
18-2243-9^①
DETENT BALL**
Replaces: 316506
9.9 - 35 HP



**18-2398
RETAINING SPRING**
Replaces: 320311
For: 2 & 3 CYL.



**18-2399
RETAINING SPRING**
Replaces: 324369
For: V-4 & V-6

NSS - Not Sold Separately

① Priced per package

APPLICATION BEGINS ON NEXT PAGE

ALL FORWARD GEARS INCLUDE PINION GEARS

HP	Year	Model	Prop Shaft	Gear Set	Fwd. Gear	Rev. Gear	Clutch
20	1985-95	ALL		18-1293	18-1287 ⑩	18-1289	18-1290
25	1985-95	ALL		18-1293	18-1287 ⑩	18-1289	18-1290
25D	1989-95	ALL	18-2288	18-2315	18-2310	18-2309	18-2308
30	1984-96	ALL		18-1293	18-1287 ⑩	18-1289	18-1290
35	1984-94	ALL ⑨		18-1293	18-1287 ⑩	18-1289	18-1290
35	1987	AE, AR, AT	—	—	—	—	18-2287
40	1984-88	ALL	—	—	—	—	18-2287
40	1989-97	ALL	18-2288	18-2315	18-2310	18-2309	18-2308
48	1987-88	ALL	—	—	—	—	18-2287
48	1989-96	ALL	18-2288	18-2315	18-2310	18-2309	18-2308
50	1975	ALL	—	—	—	—	18-2287
50	1979-88	ALL	—	—	—	—	18-2287
50	1989-97	2 Cyl.	18-2288	18-2315	18-2310	18-2309	18-2308
50	1997	3 Cyl.	18-2250	—	—	18-2208	18-2209
55	1976-78	ALL	—	—	—	—	18-2287
60	1980-85	Electric Start	—	—	—	—	18-2287
60	1986-87	⑥	18-2250	—	—	18-2208	18-2209
60 ⑧	1986-87	3 Cyl.	—	—	—	—	18-2287
60	1988-97	ALL	18-2250	—	—	18-2208	18-2209
65	1984	ALL	18-2250	—	—	18-2208	18-2209
65	1987	ALL	18-2250	—	—	18-2208	18-2209
65	1990-91	ALL	18-2250	—	—	18-2208	18-2209
65 COMM	1985-97	ALL	18-2250	—	—	18-2208	18-2209
65 COMM Remote	1992-95	ALL	18-2250	—	—	18-2208	18-2209
65 COMM Rope	1992-95	ALL	18-2250	—	—	18-2208	18-2209
70	1975	①	N/A	—	—	18-2208	18-2209
70	1976	ALL	N/A	—	—	18-2208	18-2209
70	1977-85	⑥	18-2250	—	—	18-2208	18-2209
70 ⑧	1979-85	ALL	—	—	—	—	18-2287
70	1986-97	ALL	18-2250	—	—	18-2208	18-2209
70TTL	1992-95	ALL	18-2250	—	—	18-2208	18-2209
75 ⑧	1975-87	ALL	—	—	—	—	18-2287
75	1976	⑥	N/A	—	—	18-2208	18-2209
75	1977	⑥	18-2250	—	—	18-2208	18-2209
75	1978-80	□	18-2250	—	—	18-2208	18-2209
75	1982-87	⑥	18-2250	—	—	18-2208	18-2209
75	2000-01	FPX & FX	18-2251	18-1291	—	—	18-2216
85	1973-77	ALL	—	—	—	18-2219	—
85	1978-80	ALL	18-2252	18-2221	18-2218	18-2219	18-2220
85	1991-95	ALL	18-2252	18-2221	18-2218	18-2219	18-2220
88	1987-96	ALL	18-2252	18-2221	18-2218	18-2219	18-2220
90	1981-98 ②	ALL	18-2252	18-2221	18-2218	18-2219	18-2220
90	1995-01	25" Transoms	18-2251	18-1291	—	—	18-2216
90	1999	ALL	18-1725	18-2221	18-2218	18-2219	18-2220
100	1979-80,90-95	ALL	18-2252	18-2221	18-2218	18-2219	18-2220
100 COMM	1984-90	ALL	18-2187	—	—	—	18-2216
100 COMM	1989-90,1998	③	18-2252	18-2221	18-2218	18-2219	18-2220
100 COMM	1993-01	ALL	18-2251	18-1291	—	—	18-2216
105 JET	1992	ALL	18-2251	18-2217	—	—	18-2216
105	1997-99	ALL	18-2251	18-1291	—	—	18-2216
105 COMM	2000-01	ALL	18-2251	18-1291	—	—	18-2216
110	1986-89	ALL	18-2252	18-2221	18-2218	18-2219	18-2220

① Models with "E" suffix only
 ② Models with " WTP" only
 ③ Models with "S" prefix only
 ④ Models "ESX" only

⑤ All models except "ESX"
 ⑥ 20" Transom only
 ⑦ All models except 140TX
 ⑧ 15" Models

⑨ 1993 Models "ESX" "F" suffix only
 ⑩ Except 1999 "FCX" Models
 ⑪ Except 1998 "FSX" Models
 ⑫ Models with "F" suffix only

⑬ Models with "S" suffix only
 ⑭ Fits new style reverse gear with
 6 clutch ears only
 ⑮ Except AE, AR & AT models
 ⑯ Pinion 18-1288 sold separately

ALL FORWARD GEARS INCLUDE PINION GEARS

HP	Year	Model	Prop Shaft	Gear Set	Fwd. Gear	Rev. Gear	Clutch
112	1994-96	ALL	18-2252	18-2221	18-2218	18-2219	18-2220
115	1973-76	ALL	—	—	—	18-2219	—
115	1977	ALL	18-2252	—	—	18-2219	18-2220
115	1978-85, 1990-98	ALL	18-2252	18-2221	18-2218	18-2219	18-2220
115	1995-01	25" Transoms	18-2251	18-1291	—	—	18-2216
115	1999	20" 60 degree V4	18-2252	18-2221	18-2218	18-2219	18-2216
115	1999	25" 60 degree V4	18-2251	—	—	—	18-2216
120	1985	ALL	—	—	—	—	18-2216
120	1986-92	ALL	18-2252	18-2221	18-2218	18-2219	18-2220
120	1993-94	TL & TX ⑦	18-2252	18-2221	18-2218	18-2219	18-2220
120	1993-94	TX ⑥	18-2251	18-1291	—	—	18-2216
125 COMM	1989-90	④	18-2252	18-2221	18-2218	18-2219	18-2200
125 COMM	1989-90	⑤	18-2187	—	—	—	18-2216
125 COMM	1992-94, 1996	⑤	18-2251	—	—	—	18-2216
125	1991	②	18-2251	—	—	—	18-2216
125	1991-95	④ ⑨	18-2252	18-2221	18-2218	18-2219	18-2220
125	1993-95	⑥	18-2251	18-1291	—	—	18-2216
125	1996-98	ALL	18-2251	18-1291	—	—	18-2216
130	1995-01	TL & TX & 25"	18-2251	18-1291	—	—	18-2216
135	2001	ALL	18-2251	18-1291	—	—	18-2216
140	1977	ALL	18-2252	—	—	—	18-2220
140	1978-84, 1986-87	ALL	18-2252	18-2221	18-2218	18-2219	18-2220
140	1985	ALL	18-2187	—	—	—	18-2216
140	1988-94	⑦	18-2252	18-2221	18-2218	18-2219	18-2220
140	1988-90	TX	18-2187	—	—	—	18-2216
140	1993-94	TX ⑥	18-2251	18-1291	N/A	N/A	18-2216
150	1978-79	ALL	—	—	—	—	18-2216 □
150	1980-87	CHECK O.E.	18-2187	18-2217	—	—	18-2216
150	1988-89, 90	ALL	18-2187	18-2217	—	—	18-2216
150	1991-99 ①	ALL	18-2251	18-2290	—	—	18-2216
150	2004	ALL	18-2251	18-1292	N/A	N/A	18-2216
150 COMM	1993-96	ALL	18-2251	18-2290	—	—	18-2216
155 COMM	1984-88	ALL	18-2187	—	—	—	18-2216
155 COMM WTP	1986-88	ALL	18-2187	—	—	—	18-2216
155 COMM							
WTL & WTX	1989-90	ALL	18-2187	—	—	—	18-2216
155 COMM	1989-90	②	18-2187	18-2217	—	—	18-2216
155 COMM	1991-92	ALL	18-2251	18-2290	—	—	18-2216
175	1977	ALL	—	N/A	N/A	N/A	18-2220
175	1978-83	ALL	—	—	—	—	18-2216 □
175	1985-90	ALL	18-2187	18-2217	—	—	18-2216
175/185	1991-99 ①	ALL	18-2251	18-2290	—	—	18-2216
185	1984-85	ALL	18-2187	18-2217	—	—	18-2216
200	1979-86	ALL	—	18-2217	—	—	18-2216
200	1988-90	ALL	18-2187	18-2217	—	—	18-2216
200	1991-99	ALL	18-2251	18-2290	—	—	18-2216
200	2002-03	ALL	18-2251	18-1292	N/A	N/A	18-2216
220	1987	ALL	18-2187	18-2217	—	—	18-2216
225	1986-87	ALL	—	18-2217	—	—	18-2216
225	1988-89	ALL	18-2187	18-2217	—	—	18-2216
225	1991-99	ALL	18-2251	18-2290	—	—	18-2216
225	2002-04	ALL	18-2251	18-1292	N/A	N/A	18-2216

② Models with "WTP" only
 ③ Models with "S" prefix only
 ④ Models "ESX" only
 ⑤ All models except "ESX"

⑥ 20" Transom only
 ⑦ All models except 140TX
 ⑧ 15" Models
 ⑨ 1993 Models "ESX" "F" suffix only

① Except 1999 "FCX" Models
 ② Except 1998 "FSX" Models
 ③ Models with "F" suffix only
 ④ Models with "S" suffix only

⑤ Fits new style reverse gear with 6 clutch ears only
 ⑥ Except AE, AR & AT models
 ⑦ Pinion 18-1288 sold separately

ALL FORWARD GEARS INCLUDE PINION GEARS

HP	Year	Model	Prop Shaft	Gear Set	Fwd. Gear	Rev. Gear	Clutch
235	1979-85	ALL	—	18-2217	—	—	18-2216
250	1991-99	ALL	18-2251	—	—	—	18-2216
250	2002-03	ALL	18-2251	18-1292	N/A	N/A	18-2216
275	1985-88	ALL	18-2251	—	—	—	18-2216
3.6L	1985-87	ALL	18-2251	—	—	—	18-2216
300	1988-95	ALL	18-2251	—	—	—	18-2216

- ① Models with "E" suffix only
- ② Models with "WTP" only
- ③ Models with "S" prefix only
- ④ Models "ESX" only
- ⑤ All models except "ESX"
- ⑥ 20" Transom only
- ⑦ All models except 140TX
- ⑧ 15" Models
- ⑨ 1993 Models "ESX" "F" suffix only
- ⑩ Except 1999 "FCX" Models
- ⑪ Except 1998 "FSX" Models
- ⑫ Models with "F" suffix only
- ⑬ Models with "S" suffix only
- ⑭ Fits new style reverse gear with 6 clutch ears only
- ⑮ Except AE, AR & AT models
- ⑯ Pinion 18-1288 sold separately

SEA DRIVE SHAFTS AND GEARS

HP	Year	Model	Prop Shaft	Gear Set	Fwd. Gear	Rev. Gear	Clutch
1.6	1990 ①	ALL	18-2252	18-2221	18-2218	18-2219	18-2220
2	1990 ②	ALL	18-2187	—	—	—	18-2216
2	1990 ①	ALL	18-2187	—	—	—	18-2216
3	1990 ①	ALL	18-2187	18-2217	—	—	18-2216
3	1990	ALL	18-2187	18-2217	—	—	18-2216
4	1990	ALL	18-2187	—	—	—	18-2216
1.6	1989	ALL	18-2252	18-2221	18-2218	18-2219	18-2220
2	1989	ALL	18-2187	—	—	—	18-2216
3	1989	ALL	18-2187	18-2217	—	—	18-2216
4	1989	ALL	18-2187	—	—	—	18-2216
1.6	1988	ALL	18-2252	18-2221	18-2218	18-2219	18-2220
2	1988	ALL	18-2187	—	—	—	18-2216
3	1988	ALL	18-2187	18-2217	—	—	18-2216
1.6	1987	ALL	18-2252	18-2221	18-2218	18-2219	18-2220
1.8	1987	ALL	18-2252	18-2221	18-2218	18-2219	18-2220
2.7	1987	ALL	18-2187	18-2217	—	—	18-2216
3.6	1987	ALL	18-2187	—	—	—	18-2216
1.6	1986	ALL	18-2252	18-2221	18-2218	18-2219	18-2220
2.6	1986	ALL	18-2187	18-2217	—	—	18-2216
1.6 V-4	1985 ③	ALL	18-2252	18-2221	18-2218	18-2219	18-2220
2.6 V-6	1985 ④	ALL	18-2187	—	—	—	18-2216
2.5/2.6	1985 ③	ALL	18-2187	—	—	—	18-2216
1.6 V-4	1984 ③	ALL	18-2252	18-2221	18-2218	18-2219	18-2220
2.6 V-6	1984 ④	ALL	18-2187	—	—	—	18-2216
2.5/2.6	1984 ③	ALL	18-2187	—	—	—	18-2216
1.6	1983	ALL	18-2252	18-2221	18-2218	18-2219	18-2220
2.6	1983	ALL	N/A	—	—	—	18-2216
2.5/2.6	1982	ALL	—	—	—	—	18-2216

- ① Models with "E" suffix only
- ② Models with "WTP" only
- ③ Models with "S" prefix only
- ④ Models "ESX" only



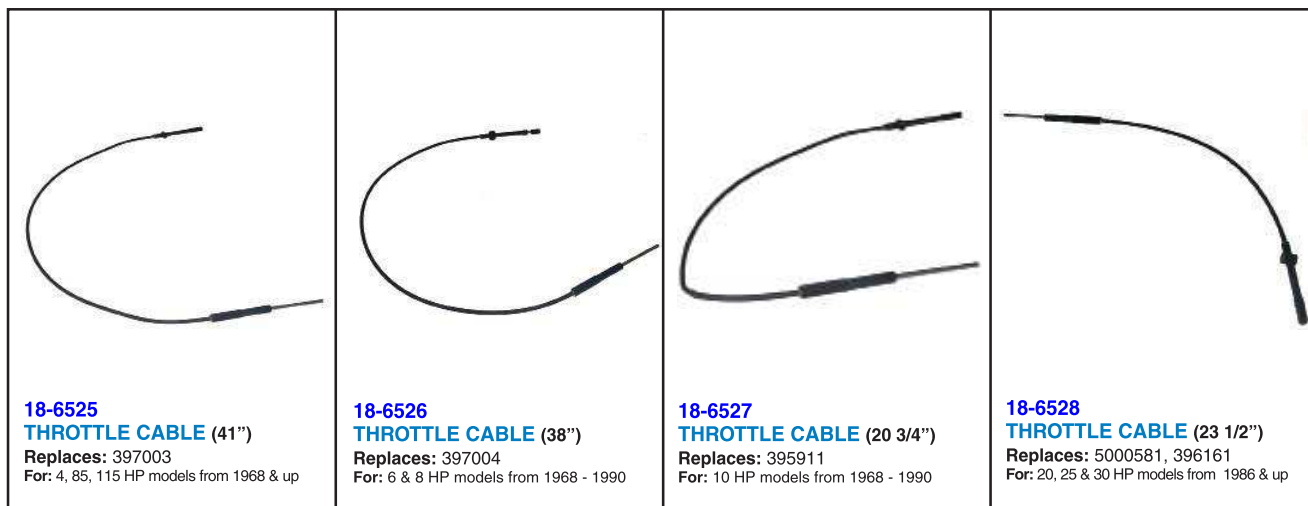

THROTTLE CABLE APPLICATION

HP	Year Start	Year Stop	Throttle Cable	HP	Year Start	Year Stop	Throttle Cable
4	1987	1996	18-6525	25	1986	1989	18-6528
6	1985	1990	18-6526	25	1999	2005	18-6528
8	1985	1990	18-6526	30	1986	1989	18-6528
9.9	1986	1992	18-6527	30	1999	2005	18-6528
14	1988	1989	18-6526	35	1986	1989	18-6528
15	1986	1992	18-6527	85	1991	1995	18-6525
20	1986	1989	18-6528	115	1994	1995	18-6525

SHIMS

	Part #	Desc.	O.E. #	I.D.	Part #	Desc.	O.E. #	I.D.
	18-1718 ^②	Kit	—		18-2229 ^{① ③}	.003 Shim	323362	1.24
	18-2224 ^③	.003 Shim	320166	1.58	18-2230	.004 Shim	323361	1.24
	18-2225 ^③	.004 Shim	320167	1.56	18-2231	.005 Shim	314745	1.24
	18-2226 ^③	.005 Shim	320168	1.53	18-2232	.003 Shim	323889	1.22
	18-2227 ^③	.006 Shim	320169	1.53	18-2233	.004 Shim	323890	1.22
	18-2228	.007 Shim	320170	1.53	18-2234 ^{① ③}	.005 Shim	317232	.22

HP	Year	0.003 Shim	0.004 Shim	0.005 Shim	0.006 Shim	0.007 Shim
60	1980-1987	18-2224	18-2225	18-2226	18-2227	18-2228
60	1988-95	18-2232	18-2233	18-2234	—	—
60SST	1989-1990	18-2224	18-2225	18-2226	18-2227	18-2228
60TTL	1992	18-2232	18-2233	18-2234	—	—
65C	1984-91,93-95	18-2232	18-2233	18-2234	—	—
65C	1992	18-2232	18-2233	18-2234	—	—
70	1975-76	18-2232	18-2233	18-2234	—	—
70	1977-85	18-2224	18-2225	18-2226	18-2227	18-2228
70	1986-95	18-2232	18-2233	18-2234	—	—
70TTL	1992	18-2232	18-2233	18-2234	—	—
75	1975-1988	18-2224	18-2225	18-2226	18-2227	18-2228

① STD PKG OF 2 ② Includes 1 each of 18-2229, 18-2230 & 18-2231
 ③ This product is priced per piece. To order priced per package, please add -9 to the part number

APPLICATION CONTINUED ON NEXT PAGE

HP	Year	0.003 Shim	0.004 Shim	0.005 Shim	0.006 Shim	0.007 Shim
85	1975-79	18-2229	18-2230	18-2231	—	—
85	1980,91	18-2229	18-2230	18-2231	—	—
85TTL	1992-95	18-2229	18-2230	18-2231	—	—
88	1987-95	18-2229	18-2230	18-2231	—	—
90	1981-95	18-2229	18-2230	18-2231	—	—
100	1979	18-2229	18-2230	18-2231	—	—
100	1980,90-95	18-2229	18-2230	18-2231	—	—
100C	1984-87,89-95	18-2229	18-2230	18-2231	—	—
100PLY	1989	18-2229	18-2230	18-2231	—	—
105JET	1992-93	18-2229	18-2230	18-2231	—	—
110	1986-89	18-2229	18-2230	18-2231	—	—
115	1980-85,90-95	18-2229	18-2230	18-2231	—	—
115	1975-79	18-2229	18-2230	18-2231	—	—
120	1985-95	18-2229	18-2230	18-2231	—	—
125, 125C	1989-95	18-2229	18-2230	18-2231	—	—
125ESX	1989-90	18-2229	18-2230	18-2231	—	—
125WTPL	1990	18-2229	18-2230	18-2231	—	—
135	1975-76	18-2229	18-2230	18-2231	—	—
140	1977-79	18-2229	18-2230	18-2231	—	—
140	1980-95	18-2229	18-2230	18-2231	—	—
150	1979-95	18-2229	18-2230	18-2231	—	—
150C	1986-91,95	18-2229	18-2230	18-2231	—	—
155C	1984-87,89-95	18-2229	18-2230	18-2231	—	—
175	1977	18-2229	18-2230	18-2231	—	—
175	1978-88,90-95	18-2229	18-2230	18-2231	—	—
185	1984-85,90-95	18-2229	18-2230	18-2231	—	—
200	1976-77	18-2229	18-2230	18-2231	—	—
200	1978-83,86-95	18-2229	18-2230	18-2231	—	—
200C	1990	18-2229	18-2230	18-2231	—	—
225	1986-93	18-2229	18-2230	18-2231	—	—
235	1978-85	18-2229	18-2230	18-2231	—	—
1600cc	1988	18-2229	18-2230	18-2231	—	—
2500cc	1988	18-2229	18-2230	18-2231	—	—

① STD PKG OF 2 ② Includes 1 each of 18-2229, 18-2230 & 18-2231

③ This product is priced per piece. To order priced per package, please add -9 to the part number

Zinc is for saltwater only applications.
Magnesium is for fresh water only applications.
Aluminum is for brackish water, or if boat is used in both fresh and salt environments.

 <p>③ 18-6115 ANODE TRANSOM BRACKET Replaces: 433580 For: 60-225 (1991-93) For use on Stern Bracket</p>	 <p>③ 18-6017 ① 18-6017A ② 18-6100 ANODE Replaces: 173029, 123009 (1981-91) 9.9-115 HP For use on gearcase and transom bracket assembly</p>	 <p>18-6018 ANODE Replaces: 327606 1983-89 2HP, For Motor Leg</p>
 <p>③ 18-6024 ① 18-6024A ANODE Replaces: 393023, 436745 (1982-87) 60-300 HP For use on gearcases</p>	 <p>③ 18-6025 ANODE Replaces: 433458, 398331 (1987-92) 60-300HP For use on Stern Bracket</p>	 <p>② 18-6026 ANODE Replaces: 392462 For exhaust housing, 2 & 3 Cyl. (1984-99)</p>
 <p>③ 18-6095 ① 18-6095A ANODE Replaces: 431708 (1988-90) 45-300 HP For use on Prop Shaft Bearing Carrier</p>	 <p>③ 18-6020 ANODE Replaces: 976669 (1969-89) Kit for V4 & V6</p>	 <p>③ 18-6027 ANODE Replaces: 392123 (1982-98) 40-300 HP Front Lower Leg Extension</p>

① Aluminum ② Magnesium ③ Zinc

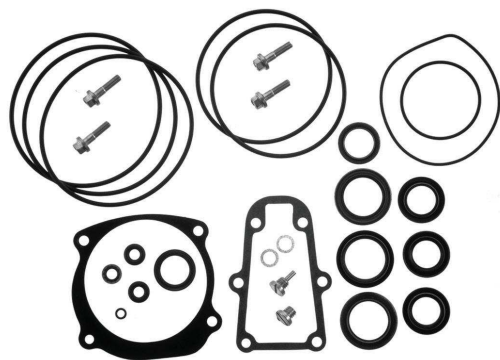

18-2623
LOWER UNIT SEAL KIT
Replaces: 439141

--- CONTAINS ---			
Part #	Desc.	O.E. #	Qty.
18-0110	Shift Housing Gasket	314082	1
18-2001	Seal	330137	2
18-2002	Seal	320862	2
18-2026	Seal	321453	2
18-2061	Seal	329922	1
18-2062	Seal	329923	1
18-2377	Screw	316563	4
18-2378	Magnetic Drain Screw	318544	1
18-2536	O-Ring	315788	1
18-2557	Impeller Gasket	338484	1
18-4248	Washer	311598	2
18-7109	O-Ring	317178	1
18-7120	O-Ring	307853	1
18-7127	O-Ring	313446	1
18-7130	O-Ring	314728	1
18-7133	O-Ring	305123	2
18-7137	O-Ring	318372	2
18-7142	O-Ring	322119	1
18-7144	O-Ring	333572	3
18-7145	O-Ring	332584	1
18-7475	Washer	328743	4
18-8300	Seal	341280	1
18-8301	Seal	341281	1

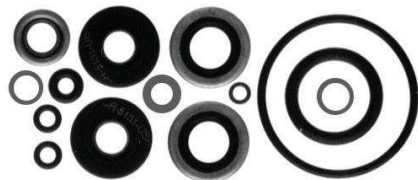

18-2656
LOWER UNIT SEAL KIT
Replaces: 396350



18-2657
LOWER UNIT SEAL KIT
Replaces: 396352

--- CONTAINS ---			
Part #	Desc.	O.E. #	Qty.
18-2025	Oil Seal	318971	1
18-2028	Oil Seal	321480	2
18-2029	Oil Seal	321481	2
18-4248	Washer	311598	2
18-7100	O-Ring	301877	1
18-7104	O-Ring	308627	1
18-7120	O-Ring	307853, 322598	1
18-7139	O-Ring	319085	1
18-7145	O-Ring	333572	2

--- CONTAINS ---			
Part #	Desc.	O.E. #	Qty.
18-0882	Shift Rod Gasket	304764	1
18-0108	Lower Gearcase Gasket	324449	1
18-3360	Impeller Housing Gasket	329390	1
18-7411	O-Ring	---	1
18-2027	Oil Seal	321459	2
18-2031	Oil Seal	321787	1
18-2063	Oil Seal	330327	1
18-4248	Washer	311598	2
18-7100	O-Ring	301877	1
18-7145	O-Ring	333572	2
18-7475	Quad Ring	332583	1

18-2658
LOWER UNIT SEAL KIT
Replaces: 396351



— CONTAINS —

Part #	Desc.	O.E. #	Qty.
18-0124	Impeller Plate Gasket	325537	1
18-2026	Oil Seal	321453	2
18-2033	Oil Seal	321928	1
18-2065	Oil Seal	332261	1
18-2539	Rubber Seal	328753	1
18-4248	Washer	311598	2
18-7100	O-Ring	301877	1
18-7105	O-Ring	311338	2
18-7108	O-Ring	313893	1
18-7109	O-Ring	317178	3
18-7145	O-Ring	333572	2
18-7146	O-Ring	554545	1
18-7180	O-Ring	303347	1
18-2030	Oil Seal	321786	1
18-2027	Oil Seal	321459	1

18-2659
LOWER UNIT SEAL KIT
Replaces: 396355



— CONTAINS —

Part #	Desc.	O.E. #	Qty.
18-0969	Impeller Housing Gasket	319586	1
18-2059	Oil Seal	321466	1
18-2060	Oil Seal	321467	2
18-2064	Oil Seal	332205	1
18-2532	Foam Seal	305762	1
18-2537	Rubber Seal	324937	1
18-2855	Shift Housing Cover to Gear Case Gasket	314082	1
18-4248	Washer	311598	2
18-7115	O-Ring	302588	1
18-7120	O-Ring	307853	1
18-7137	O-Ring	318372	1
18-7140	O-Ring	320303	1
18-7145	O-Ring	333572	2
18-7475	Quad Ring	332584	3

18-2660
LOWER UNIT SEAL KIT
Replaces: 396349

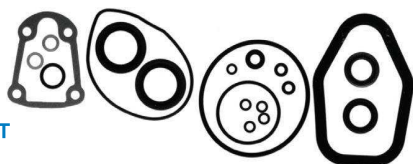

— CONTAINS —

Part #	Desc.	O.E. #	Qty.
18-2059	Oil Seal	321466	1
18-2064	Oil Seal	332205	1
18-2537	Rubber Seal	324937	1
18-2855	Shift Housing Cover to Gearcase Gasket	314082	1
18-4248	Washer	311598	2
18-7120	O-Ring	307853	1
18-7127	O-Ring	313446	1
18-7128	O-Ring	313754	1
18-7137	O-Ring	318372	1
18-7145	O-Ring	333572	2
18-7475	Quad Ring	332584	4
18-7174	O-Ring	910582, 326649	1
18-2001	Oil Seal	330137	2

18-2679
LOWER UNIT SEAL KIT

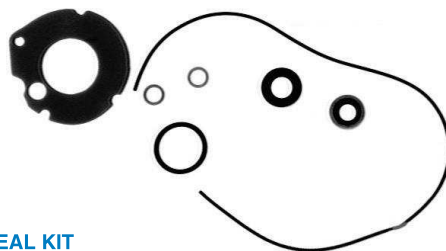

— CONTAINS —

Part #	Desc.	O.E. #	Qty.
18-2022	Oil Seal	303345	1
18-2035	Oil Seal	327031	1
18-2891	Bearing Housing Gasket	303339	1
18-4248	Washer	311598	2
18-7100	O-Ring	301877	1
18-7117	O-Ring	303360	1
18-7120	O-Ring	307853	1
18-2534	Spaghetti Seal	309044	1

18-2680
LOWER UNIT SEAL KIT

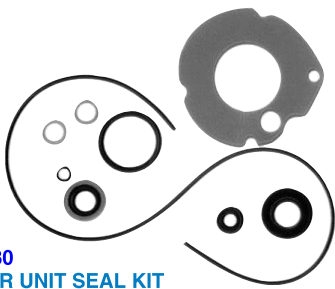

— CONTAINS —

Part #	Desc.	O.E. #	Qty.
18-2023	Oil Seal	313282	1
18-2035	Oil Seal	327031	1
18-2891	Bearing Housing Gasket	303339	1
18-4248	Washer	311598	2
18-7100	O-Ring	301877	1
18-7117	O-Ring	303360	1
18-7120	O-Ring	307853	1
18-2534	Spaghetti Seal	309044	1

18-2681
LOWER UNIT SEAL KIT



— CONTAINS —

Part #	Desc.	O.E. #	Qty.
18-2023	Oil Seal	313282	1
18-2024	Oil Seal	314167	1
18-2891	Bearing Housing Gasket	303339	1
18-4248	Washer	311598	2
18-7100	O-Ring	301877	1
18-7117	O-Ring	303360	1
18-7120	O-Ring	307853	1
18-2534	Spaghetti Seal	309044	1

18-2682
LOWER UNIT SEAL KIT

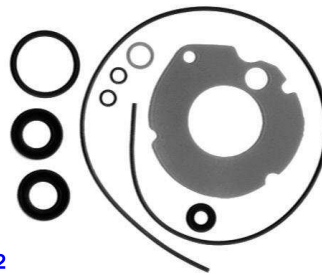

— CONTAINS —

Part #	Desc.	O.E. #	Qty.
18-2022	Oil Seal	303345	2
18-2891	Bearing Housing Gasket	303339	1
18-4248	Washer	311598	2
18-7100	O-Ring	301877	1
18-7117	O-Ring	303360	1
18-7120	O-Ring	307853	1
18-2534	Spaghetti Seal	309044	1

18-2683
LOWER UNIT SEAL KIT

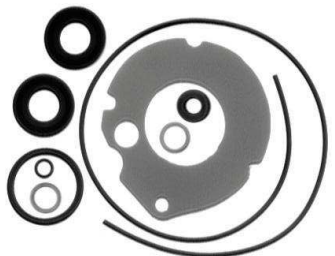

— CONTAINS —

Part #	Desc.	O.E. #	Qty.
18-2023	Oil Seal	313282	2
18-2891	Bearing Housing Gasket	303339	1
18-4248	Washer	311598	2
18-7100	O-Ring	301877	1
18-7117	O-Ring	303360	1
18-7120	O-Ring	307853	1
18-2534	Spaghetti Seal	309044	1

18-2684
LOWER UNIT SEAL KIT

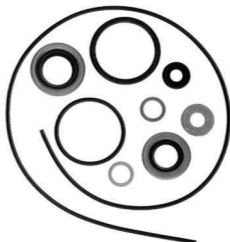

— CONTAINS —

Part #	Desc.	O.E. #	Qty.
18-0882	Shift Rod Gasket	304764	1
18-2032	Oil Seal	321788	1
18-4248	Washer	311598	2
18-7100	O-Ring	301877	1
18-7120	O-Ring	307853	1
18-2031	Oil Seal	321787	1
18-2534	Spaghetti Seal	309044	1

18-2685
LOWER UNIT SEAL KIT



— CONTAINS —

Part #	Desc.	O.E. #	Qty.
18-2030	Oil Seal	321786	3
18-2031	Oil Seal	321787	1
18-4248	Washer	311598	2
18-7100	O-Ring	301877	1
18-7112	O-Ring	302493	1
18-7120	O-Ring	307853	1
18-2534	Spaghetti Seal	309044	1
18-0882	Shift Rod Gasket	304764	1



18-2686
LOWER UNIT SEAL KIT

— CONTAINS —

Part #	Desc.	O.E. #	Qty.
18-0882	Shift Rod Gasket	304764	1
18-2005	Oil Seal	313284	1
18-2021	Oil Seal	302564	1
18-4248	Washer	311598	2
18-7100	O-Ring	301877	1
18-7115	O-Ring	302588	1
18-7120	O-Ring	307853, 322598	1



18-2687
LOWER UNIT SEAL KIT

— CONTAINS —

Part #	Desc.	O.E. #	Qty.
18-2005	Oil Seal	313284	1
18-4248	Washer	311598	2
18-7120	O-Ring	307853, 322598	1
18-7152	O-Ring	307082	1
18-2027	Oil Seal	321459	1
18-7143	O-Ring	322501	1
18-0173	Oil Seal	313283	1
18-7428	Rubber Seal	307103	1

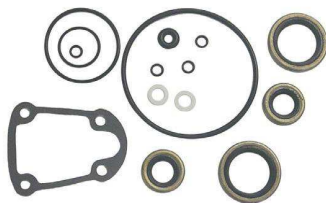

18-2688
LOWER UNIT SEAL KIT

— CONTAINS —

Part #	Desc.	O.E. #	Qty.
18-2027	Oil Seal	321459	2
18-2855	Shift Housing Cover to Gearcase Gasket	314082	1
18-4248	Washer	311598	2
18-7100	O-Ring	301877	1
18-7109	O-Ring	317178	4
18-7127	O-Ring	313446	1
18-7128	O-Ring	313754	1
18-2001	Oil Seal	330137	2
18-7129	O-Ring	314491	1

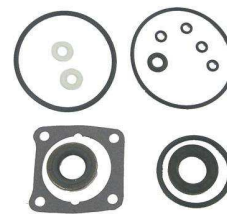

18-2689
LOWER UNIT SEAL KIT

— CONTAINS —

Part #	Desc.	O.E. #	Qty.
18-0173	Oil Seal	313283	1
18-0174	Oil Seal	326716	1
18-0886	Lower Gearcase Gasket	307099	1
18-4248	Washer	311598	2
18-7115	O-Ring	302588	1
18-7118	O-Ring	305242	1
18-7120	O-Ring	307853, 322598	4
18-7152	O-Ring	307082	1
18-7428	O-Ring	307103	1

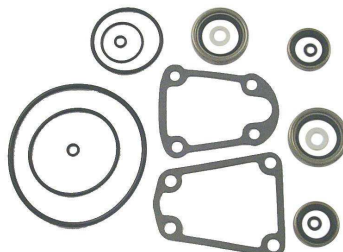

18-2690
LOWER UNIT SEAL KIT

— CONTAINS —

Part #	Desc.	O.E. #	Qty.
18-2855	Shift Housing Cover to Gearcase Gasket	314082	1
18-2874	Solenoid Cover Gasket	314876	1
18-4248	Washer	311598	2
18-7120	O-Ring	307853, 322598	4
18-7127	O-Ring	313446	1
18-7129	O-Ring	314491	1
18-7130	O-Ring	314728	1
18-7126	O-Ring	313340	1

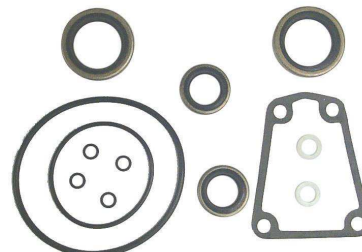

18-2691
LOWER UNIT SEAL KIT

— CONTAINS —

Part #	Desc.	O.E. #	Qty.
18-2874	Solenoid Cover Gasket	314876	1
18-4248	Washer	311598	2
18-7109	O-Ring	317178	4
18-7127	O-Ring	313446	1
18-2001	Oil Seal	330137	2
18-7130	O-Ring	314728	1
18-2059	Oil Seal	321466	2

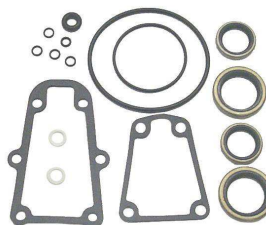

18-2692
LOWER UNIT SEAL KIT

— CONTAINS —

Part #	Desc.	O.E. #	Qty.
18-0110	Shift Housing Gasket	324670	1
18-2026	Oil Seal	321453	2
18-2874	Solenoid Cover Gasket	314876	1
18-4248	Washer	311598	2
18-7109	O-Ring	317178	4
18-7120	O-Ring	322598	1
18-7127	O-Ring	313446	1
18-7130	O-Ring	314728	1
18-7137	O-Ring	318372	1
18-2001	Oil Seal	330137	2

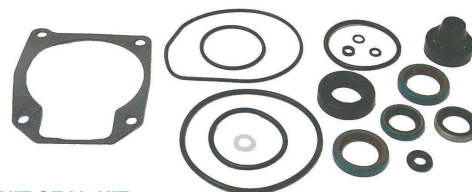

18-2694
LOWER UNIT SEAL KIT

Replaces: 433550

— CONTAINS —

Part #	Desc.	O.E. #	Qty.	Part #	Desc.	O.E. #	Qty.
18-2709	Wear Plate Gasket	336530	1	18-7481	Seal	315788	1
18-7115	O-Ring	302588	1	18-2708	Seal	333758	1
18-7127	O-Ring	313446	1	18-2059	Oil Seal	321466	2
18-7120	O-Ring	307853, 322598	1	18-2018	Oil Seal	0767970	2
18-7172	O-Ring	553126	1	18-2064	Oil Seal	332205	1
18-7137	O-Ring	318372	1	18-2705	Seal	315748	1
18-7475	O-Ring	332584	1	18-4248	Washer	311598	1
				18-7173	O-Ring	310327, 910582	1

APPLICATION BEGINS ON PAGE NEXT PAGE



**18-8383
SEAL KIT**

Replaces: 5000309
For: E-Tec 40, 50, 60 HP



**18-8384
SEAL KIT**

Replaces: E-Tec
5006373
For: E-Tec 75/90/115/150/175/200/225/250 HP



**18-8387
LOWER UNIT SEAL KIT**

Replaces: 5007987
For: E-Tec 15, 25, 30 (2010 & Up)



**18-8337
LOWER UNIT SEAL KIT**

Replaces: 5031456
For: 40/50 HP 4 stroke (1999-2003)

— CONTAINS —

Part #	Desc.	O.E. #	Qty.
18-0461	Water Pump Gasket	—	1
18-7151	O-Ring	—	1
18-7413	O-Ring	303191	2
18-8331	Drain Plug Gasket	—	3
18-8334	Shift Shaft Seal	—	1
18-8345	Seal	—	2



**18-74108
GEAR HOUSING SEAL KIT**

Replaces: 5030973
Fits: Johnson Evinrude 60/70 4-Stroke

GEAR HOUSING SEAL KITS APPLICATION

Model	Year	Seal Kit	Model	Year	Seal Kit		
5.5	⑧	1955-67	18-2679	85	1991-95	18-2623	
6	⑧	1955-67	18-2679	88	1985-Up	18-2623	
6	⑨	1967-68	18-2680	90 (Elect.)	1964-65	18-2689	
6	⑩	1968-79	18-2681	90 (V-4)	1973-83	18-2692	
7.5	⑧	1955-67	18-2679	90	1985-Up	18-2623	
9.5 (M Suffix)		1964-67	18-2682	100 (Large Prop Shaft)	1971-72	18-2691	
9.5 (B Suffix)		1967-73	18-2683	100 (V-4)	1973-83	18-2692	
9.9/15		1974-Up	18-2656	100 (Comm)	1984-90	18-2623	
9.9/15 (4 Stroke)		1974-Up	18-2656	100 (Comm)	1991-95	18-2623	
10		1958-67	18-2682	100	③	1991-92	18-2623
18		1958-73	18-2684	110 (V-4)	1973-83	18-2692	
20		1966-73	18-2684	110	1985-89	18-2623	
20		1979-82	18-2684	115 (Small Prop Shaft)	1969-71	18-2690	
20		1985-Up	18-2658	115 (V-4)	1973-83	18-2692	
25		1955-59	18-2686	115	1985-Up	18-2623	
25		1968-78	18-2684	120	1985	18-2623	
25		1979-82	18-2685	120	1986-92	18-2623	
25		1984	18-2657	120	1993	18-2623	
25		1985-Up	18-2658	125 (Large Prop Shaft)	1971-72	18-2691	
25	①	1990-95	18-2694	125	④	1991-92	18-2623
25 (Comm)		1985-Up	18-2657	125		1993	18-2623
28		1962-70	18-2686	125 (Comm)	1991-93	18-2623	
28		1985-98	18-2657	135 (V-4)	1973-83	18-2692	
30		1955-59	18-2686	140 (V-4)	1973-83	18-2692	
30		1976-95	18-2658	140	1985	18-2623	
33		1962-70	18-2686	140	⑤	1986-92	18-2623
35		1955-59	18-2686	140	⑥	1992-93	18-2623
35		1977-92	18-2658	140	①	1992-95	18-2623
40 (Manual Shift)		1960-73	18-2686	150 (V-6)		1978-86	18-2623
40 (Elect. Shift)		1962-70	18-2687	150	⑦	1991	18-2623
40		1976-88	18-2659	150		1991-95	18-2623
40		1989-Up	18-2694	155 (Comm)		1984-90	18-2623
48		1976-88	18-2659	155 (Comm)		1991-93	18-2623
48		1989-96	18-2694	175 (V-6)		1977-86	18-2623
50		1971-74	18-2688	175	②	1991	18-2623
50		1976-88	18-2659	175	⑦	1992	18-2623
50		1989-Up	18-2694	175		1991-95	18-2623
50 (3 cyl.)		1995-Up	18-2660	185		1991-93	18-2623
55		1968-69	18-2690	200 (V-6)		1976-86	18-2623
55		1976-88	18-2659	200		1991-95	18-2623
60 (Manual/Elect.)		1960-68	18-2689	225		1991-95	18-2623
60		1970-71	18-2690	235 (V-6)		1977-86	18-2623
60 (2 cyl.)		1976-88	18-2659	V-8	⑦	1985-91	18-2623
60 (3 cyl.)		1978-Up	18-2660	250 (V-8)		1991-95	18-2623
65 (Manual/Elect.)		1960-68	18-2689	300 (V-8)		1991-95	18-2623
65		1978-Up	18-2660				
70		1978-Up	18-2660				
				OMC SEA DRIVE			
75 (Manual/Elect.)		1960-68	18-2689	1.6L		1985-90	18-2623
75		1978-91	18-2660	1.8L		1987	18-2623
75 (Small Gearcase)		1976-88	18-2659	2.0L		1988-90	18-2623
V-4		1978-84	18-2623	2.5L		1984-85	18-2623
85 (Manual/Elect.)		1968	18-2689	2.6L		1984-86	18-2623
85 (Small Prop Shaft)		1969-71	18-2690	2.7L		1987	18-2623
85 (Large Prop Shaft)		1971-72	18-2691	3.0L		1988-90	18-2623
85 (V-4)		1973-83	18-2692	3.6L		1987	18-2623
				4.0L		1989-90	18-2623

- ① "D" Suffix Only
- ② Models "GL" & "EX" only
- ③ 1992 Models except WTLNE, WTXENE
- ④ 1992 ESX Models only

- ⑤ 1992 TL Models only
- ⑥ CX Models only
- ⑦ 1992 Counter Rotation
- ⑧ 1967 "D" Suffix Only

- ⑨ 1967 "S" Suffix Only
- 1968 "C" Suffix Only
- ⑩ 1968 "A" & "R" Suffixes Only
- ⑪ TX & Counter Rotation Models

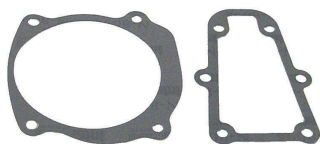

18-2595
SHIFT ROD & WEAR PLATE GASKET SET
 Replaces: 982132

18-2595 SHIFT ROD & WEAR PLATE GASKET SET APPLICATION					
HP	YEARS	HP	YEARS	HP	YEARS
85	1978-80	120	1985-90	200	1976-90
88	1987-90	125	1989-90	225	1986-90
90	1981-90	140	1977-90	235	1978-85
100	1979-90	150	1978-90	275	1985-90
100C	1984-89	155C	1984-90	3.6L	1985-90
110	1986-89	175	1977-90	300	1985-90
115	1978-90	185	1984-90		

OIL SEALS



Part #	O.E. #	Shaft Size	Dimensions (in)		Part #	O.E. #	Shaft Size	Dimensions (in)	
			O.D.	Width				O.D.	Width
18-0173	313283	0.795	1.320	0.307	18-2059	318223, 321466	0.750	1.126	0.200
18-0174	326716	0.750	1.382	0.242	18-2060	303804, 321467	1.000	1.375	0.250
18-0542	321831, 315288	0.750	1.253	0.186	18-2061	329922	0.822	1.375	0.195
18-0543	321895, 313507	1.540	1.926	0.243	18-2062	329923	0.875	1.375	0.207
18-0559	332585	0.285	0.357	0.940	18-2063	330327	0.625	1.124	0.188
18-2000	309989	1.375	2.000	0.313	18-2064	332205	0.730	1.130	0.194
18-2001	330137	1.125	1.624	0.250	18-2065	332261	0.625	1.375	0.195
18-2002	320862	1.188	1.692	0.250	18-2066	911019	1.000	1.375	0.435
18-2005	313284	0.625	1.128	0.250	18-2067	911685	2.000	2.509	0.315
18-2012	310599	1.000	1.499	0.250	18-2068	911701	0.500	0.905	0.250
18-2016	313992	1.187	1.875	0.250	18-2068	915702	0.500	0.905	0.250
18-2018	305987	1.000	1.375	0.250	18-2068	916058	0.500	0.905	0.250
18-2020	310649	2.500	3.000	0.250	18-2068	3853655	.500	.905	.250
18-2021	313258	0.750	1.375	0.250	18-2071	981195	1.500	2.125	0.250
18-2022	303345	0.554	1.000	0.375	18-2072	981196	1.750	2.502	0.250
18-2023	313282	0.554	1.062	0.312	18-2073	981268	1.625	2.502	0.250
18-2024	314167	0.425	0.937	0.312	18-2074	318451, 339620	1.625	2.125	0.250
18-2025	318972	0.500	0.875	0.250	18-2075	353076, 326751	1.562	2.062	0.300
18-2026	317843, 321453	0.875	1.250	0.188	18-8300	341280	0.866	1.378	0.280
18-2027	305306, 321459	0.625	1.125	0.250	18-8301	341281	1.220	1.693	0.280
18-2028	318973	0.500	1.250	0.188	18-8304	321830	20.37mm	31.8mm	6.35mm
18-2029	319256, 321481	0.687	1.250	0.250	18-8307	331103	1.100	1.628	0.448
18-2030	321786	0.625	1.125	0.188	18-8325	342786	28mm	41.5mm	7/11
18-2031	321787	0.625	1.125	0.312	18-8326	342787	18mm	29mm	8/12
18-2032	321788	0.500	1.000	0.188		911795			
18-2033	321928	0.625	1.375	0.250	18-8349	3852548	1.375	2.186	0.500
18-2034	324639	0.437	0.937	0.188	18-8350	328603	1.100	1.690	0.320
18-2035	300599, 327031	0.425	0.875	0.313	18-8351	321504, 308500	1.110	1.570	0.320
18-2058	313353	1.938	2.438	0.250	18-8367	334950	1.250	1.687	0.250

OIL SEAL APPLICATION

HP	YEARS	PROPSHAFT	QTY.	DRIVESHAFT	QTY.	UPPER CRANKCASE	QTY.	LOWER CRANKCASE	QTY.
1.5,2,2.5,3	1958-68	-	1	18-2035	1	-	-	-	-
1.5,2	1968-90	18-2035	1	18-2035	1	-	-	-	-
2.5,4	② 1973-80	18-2035	1	18-2035	2	-	-	-	-
2.5	1987	18-2034	2	18-2035	2	-	-	-	-
2.5,4	② 1981-95	-	1	18-2035	2	-	-	-	-
3 Weedless	1958-68	18-2035	1	-	-	-	-	-	-
3,4,6 Weedless	1968-82	18-2024	1	18-2024	1	-	-	-	-
4	1981-90	18-2034	2	-	-	-	-	-	-
4	1984, 1986-95	-	-	18-2034	2	-	-	-	-
4.5,7.5	1980-87	-	1	18-2034	2	-	-	-	-
5,5.5,6,7.5	① 1957-64	18-2022	1	18-2035	1	-	-	-	-
5,6,8	1980-87	-	-	18-2034	2	-	-	-	-
6	1965-67	-	1	18-2023	1	-	-	-	-
6	1968-79	18-2023	1	18-2024	1	-	-	-	-
9.5	1964-73	18-2022	1	18-2022	1	-	-	-	-
9.9	1974-83	18-2029	1	18-2028	1	18-8304	-	18-0542	1
9.9	1984-95	18-2029	1	18-2028	1	18-8304	-	18-0542+18-2032	1
10	1957-58	18-2005	1	18-2032	1	-	-	-	-
10	1959-63	18-2022	1	18-2022	1	-	-	-	-

① 1968 Models 5802M,3M,6802C,3C ② Standard Gearcase

OIL SEAL APPLICATION (Cont.)

HP	YEARS	PROPSHAFT	QTY.	DRIVESHAFT	QTY.	UPPER CRANKCASE	QTY.	LOWER CRANKCASE	QTY.
10	1981	18-2023 (inner)	1	-	-	18-8304	-	18-0542	1
10	1989	18-2031+18-2027	1	18-2063+18-2027	1	18-8304	-	18-0542+18-2032	1
14	1988-90	18-2031+18-2027	1	18-2063+18-2027	1	18-8304	-	18-0542+18-2032	1
15	1974-83	18-2029	2	18-2028	1	18-8304	-	18-0542	1
15	1984-95	18-2029	2	18-2028	1	18-8304	-	18-0542+18-2032	1
18	1957	18-2005	1	18-2032	1	18-2060	1	-	-
18	1958-73	18-2005	1	18-2032	1	18-2018	1	-	-
20	1981-82	18-2031+18-2030	1	18-2030	1	18-8351	-	-	-
20	1983	18-2031+18-2030	1	18-2027+18-2030	1	18-8351	-	-	-
20	1984	18-2025+18-2027	1	18-2063+18-2030	1	18-8351	-	-	-
20	1985-86	18-2026	1	18-2033	1	18-8350	-	-	-
20	1987-95	18-2026	1	18-2033+18-2065	1	18-8350	-	-	-
25	1969-76	18-2005	1	18-2032	1	18-2018	1	-	-
25	1977-78	18-2005	1	18-2032	1	18-8351	-	-	-
25	1979-82	18-2031+18-2030	1	18-2030	1	18-8351	-	-	-
25	1983	18-2031+18-2030	1	18-2027+18-2030	1	18-8351	-	-	-
25	1984	18-2031+18-2027	1	18-2063+18-2030	1	18-8351	-	-	-
25	1985-86	18-2026	1	18-2033	2	18-8351	-	-	-
25	1987-95	18-2026	1	18-2033+18-2065	1	18-8351	-	-	-
25C	1982	18-2030	1	18-2030	1	18-8351	-	-	-
25C	1983	18-2031+18-2027	1	18-2027+18-2030	1	18-8350	-	-	-
25C	1984-90	18-2031+18-2027	1	18-2063+18-2027	1	18-8350	-	-	-
28	1962-64	18-2021	1	18-2005	1	18-8351	-	-	-
28	1987-90	18-2031+18-2027	1	18-2063+18-2027	1	18-8350	-	-	-
30	1984-86	18-2026	1	18-2033	1	18-8350	-	-	-
30	1987-95	18-2026	1	18-2033 (inner)	1	18-8350	-	-	-
33	1965-76	18-2021	1	18-2005	1	18-8351	-	-	-
35	1957-59	18-2021	1	18-2005	1	18-2018	1	-	-
35	1976	18-2026	1	18-2027	2	18-8351	-	-	-
35	1977-86	18-2026	2	18-2033	2	18-8351	-	18-2093	-
35	1987-90	18-2026	2	18-2033 (inner)	1	18-8350	-	18-2093	-
40	1960-61	18-2021	1	18-2005	1	18-2018	1	-	-
40	1962-73	18-2021	1	18-2005	1	18-8351	-	-	-
40	1974-76	18-2021	1	18-2029	1	18-0543	1	18-2001	1
40C	1981-86	18-2021	1	18-2029	2	18-0543	1	18-2001	2
40	1984-85	18-2060	2	18-2059	2	18-0543	1	18-2001	1
40 (AR,AE,AT)	1988	18-2001	1	18-2063+18-2027	1	18-0543	1	18-8307	-
40	1986-89	18-2060	2	18-2064+18-2059	1	18-0543	1	18-8307	-
45C	1985	18-2001	2	18-2063+18-2027	1	18-0543	1	18-8307	-
45C	1986	18-2001	2	18-2064+18-2059	1	18-0543	1	18-8307	-
45C	1987	18-2001	2	18-2063+18-2027	1	18-0543	1	18-8307	-
45C	1988-94	18-2001	2	18-2063+18-2027	1	18-0543	1	18-2001	-
45C	1995	18-2001	2	18-2064+18-2059	1	18-0543	1	-	-
48	1988-95	18-2060	2	18-2064+18-2059	1	18-0543	1	18-2063 (inner)	1
50	1971-74	18-2001 (Manual)	2	18-2027	2	18-0543	1	18-2001	1
50	1975	18-2060	2	18-2059	1	18-0543	1	18-2001	1
50	1979	18-2001	2	18-2027	2	18-0543	1	18-2001	1
50	1980	18-2060	2	18-2059	1	18-0543	1	18-2001	1
50/60 (rope start)	1981-83	18-2001	2	18-2027	1	18-0543	1	18-2001	1
50/60 (Electric)	1981-83	18-2060	2	18-2059	1	18-0543	1	18-2001	1
50/60	1984-85	18-2060	2	18-2059	1	18-0543	1	18-2001	1
50/60 Small Gearcase	1986-87	18-2060	2	18-2064+18-2059	1	18-0543	1	18-2001	1
50/60 Large Gearcase	1986-87	18-2001	2	18-2064+18-2059	1	18-0543	1	18-2001	1
50/60	1988-89	18-2001	2	18-2064+18-2059	1	18-0543	1	18-2001	1
50	1990-95	18-2060	2	18-2064+18-2059	1	18-0543	1	18-2063 (inner)	1
55	1968-69	18-2012	2	18-2059	2	18-0543	1	18-2001	1
55	1976-77	18-2060	2	18-2059	2	18-0543	1	18-2001	1
55	1978	18-2059	1	18-2059	2	18-0543	1	18-2001	1
55	1979-83	18-2001	2	18-2027	1	18-0543	1	18-2001	1
55 (Electric)	1980-83	18-2012	2	18-2059	2	18-0543	1	18-2001	1
55C	1984	18-2001	2	18-2063+18-2027	1	18-0543	1	18-2001	1
55C	1985	18-2001	2	18-2063	1	18-0543	1	18-2001	1
55C	1986	18-2001	2	18-2064+18-2059	1	18-0543	1	18-8307	-
55C	1987-94	18-2001	2	18-2063+18-2027	1	18-0543	1	18-8307	-
55C	1995	18-2001	2	18-2064+18-2059	1	18-0543	1	-	-
60 (Manual Shift)	1964-68	18-0173	1	18-0174	1	-	-	-	-
60	1970	18-2012	1	18-2059	2	18-0543	1	18-2001	1
60 (3 Cylinder)	1971	18-2001	2	18-2059	2	18-0543	1	18-2001	1
60 (Rope)	1980-83	18-2001	2	18-2027	2	18-0543	1	18-2001	1
60 (Electric)	1980-83	18-2001	2	18-2059	2	18-0543	1	18-2001	1

OIL SEAL APPLICATION (Cont.)

HP	YEARS	PROPSHAFT	QTY.	DRIVESHAFT	QTY.	UPPER CRANKCASE	QTY.	LOWER CRANKCASE	QTY.
60	1984-85	18-2060	2	18-2059	2	18-0543	1	18-2001	1
60SST	1989	18-2060	2	18-2064+18-2059	1	18-0543	1	18-2001	1
60SST	1990	18-2060	2	18-2064+18-2059	1	18-0543	1	18-8307	-
60 (3 Cylinder)	1987-95	18-2001	2	18-2064+18-2059	1	18-0543	1	18-8307	-
65 (Manual Shift)	1968	18-0173	1	18-0174	1	18-0543	1	-	-
65 (3 Cylinder)	1972-73	18-2001	2	18-2059	2	18-0543	1	18-2001	1
65C	1984-85	18-2001	2	18-2059	2	18-0543	1	18-2001	1
65C	1986-89	18-2001	2	18-2064+18-2059	1	18-0543	1	18-2001	1
70 (Large Gearcase)	1974-85	18-2001	2	18-2059	2	18-0543	1	18-2001	1
70 (Large Gearcase)	1986-95	18-2001	2	18-2064+18-2059	1	18-0543	1	18-8307	-
70 (Small Gearcase)	1977-85	18-2060	2	18-2059	2	18-0543	1	18-8307	-
75 (Manual Shift)	1960-62	18-0173	1	18-0174	1	-	-	-	-
75 (Large Gearcase)	1975-84	18-2001	2	18-2059	2	18-0543	1	18-2001	1
75 (Large Gearcase)	1986-87	18-2001	2	18-2064+18-2059	1	18-0543	1	18-8307	-
75 (Small Gearcase)	1975-84	18-2060	2	18-2059	2	18-0543	1	18-2001	1
80	1966-68	18-0173	1	18-0174	1	-	-	-	-
85	1969-70	18-2012	2	18-2059	2	18-2074	1	18-2001	1
85	1971-72	18-2001	2	18-2059	2	18-2074	1	18-2001	1
85	1973-80	18-2001	2	18-2026	2	18-2074	2	18-2001	1
88	1987-94	18-2001	2	18-2061+18-2062	1	18-2074	2	18-8307	-
90	1981-83	18-2001	2	18-2026	2	18-2074	2	18-2001	1
90	1984-94	18-2001	2	18-2061+18-2062	1	18-2062	1	18-8307	-
90 Seadrive	1985-90	18-2001	2	18-2061+18-2062	1	18-2074	2	18-2001	1
100	1971-72	18-2001	2	18-2059	2	18-2074	1	18-2001	1
100	1979-80	18-2001	2	18-2026	2	18-2074	2	18-2001	1
100C	1984-90	18-2002	2	18-2061+18-2062	1	18-2074	2	18-8307	-
110	1986-88	18-2001	2	18-2061+18-2062	1	18-2074	2	18-2001	1
115	1969-70	18-2012	2	18-2059	2	18-2074	1	18-2001	1
115	1973-83	18-2001	2	18-2026	2	18-2074	1	18-2001	1
115	1984-85	18-2001	2	18-2061+18-2062	1	18-2074	2	18-2001	1
115	1990-94	18-2001	2	18-2061+18-2062	1	18-2074	2	18-8307	-
120	1985	18-2002	2	18-2061+18-2062	1	18-2074	2	18-2075	2
120	1986-88	18-2001	2	18-2061+18-2062	1	18-2074	2	18-2075	2
120	1989	18-2002	2	18-2061+18-2062	1	18-2074	2	18-2075	2
120	1990-94	18-2001	2	18-2061+18-2062	1	18-2074	2	18-2075	2
125	1971-72	18-2001	2	18-2059	2	18-2074	1	18-2001	1
125C	1989	18-2002	2	18-2061+18-2062	1	18-2074	2	18-2075	1
125C (ESX models)	1989	18-2001	2	18-2061	1	18-2062	1	18-2075	1
135	1973-76	18-2001	2	18-2026	2	18-2074	2	18-2001	1
140	1977-83	18-2001	2	18-2026	2	18-2074	2	18-2001	1
140	1984	18-2001	2	18-2026	2	18-2074	2	18-2001	1
140	1985	18-2002	2	18-2061+18-2062	1	18-2074	2	18-2075	2
140	1986-94	18-2001	2	18-2061+18-2062	1	18-2074	2	18-2075	2
140TX	1989	18-2002	1	18-2061+18-2061	1	18-2074	2	18-2075	2
150	1978-83	18-2002	2	18-2026	2	18-2074	2	18-2075	2
150	1984	18-2002	2	18-2061+18-2062	1	18-2074	2	18-2075	2
150	1985-90	18-2002	2	18-2061+18-2062	1	18-2074	2	18-8307	-
155C	1984-85	18-2002	2	18-2061+18-2062	1	18-2074	2	18-2001	1
155C	1986-90	18-2002	2	18-2061+18-2062	1	18-2074	2	18-8307	-
175	1977-85	18-2002	2	18-2026	2	18-2074	2	18-2001	1
175	1986-90	18-2002	2	18-2061+18-2062	1	18-2074	2	18-8307	-
185	1984-85	18-2002	2	18-2061+18-2062	1	18-2074	2	18-2001	1
185	1990	18-2002	2	18-2061+18-2062	1	18-2074	2	18-2075	1
200	1976-83	18-2002	2	18-2026	2	18-2074	2	18-2001	1
200	1984-85	18-2002	2	18-2061+18-2062	1	18-2074	2	18-8307	-
200,225	1986-90	18-2002	2	18-2061+18-2062	1	18-2074	2	18-2075	2
235	1978-83	18-2002	2	18-2026	2	18-2074	2	18-2001	1
235	1984-85	18-2002	2	18-2061+18-2062	1	18-2074	2	18-2001	1
275	1985-88	18-2002	2	18-2061+18-2062	1	18-2074	2	18-2075	2

OIL SEAL APPLICATION - DRIVESHAFT HOUSING

HP	Years	Sierra Oil Seal	Qty.	Desc.	HP	Years	Sierra Oil Seal	Qty.	Desc.
5/6/6.5/8 ①	1987-90	18-2034	1	EH,L	75/80/85	1961-68	18-2060	1	PS
45/55 ①	1990	18-2063	1	EH A	90/100	1964-68	18-2060	1	PS
50/60/65	1958-68	18-2060	1	PS					

① Commercial models also
PS Pivot shaft

EH A Exhaust housing to adapter
EH,L Driveshaft to exhaust housing

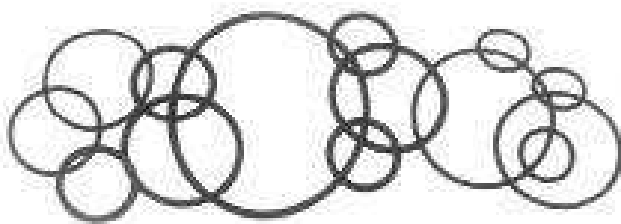

O-RINGS

Part #	O.E. #	Dimensions (in)		Part #	O.E. #	Dimensions (in)			
		I.D.	Width			I.D.	Width		
18-7100	25	301877	.245	.155	18-7145	25	333572	.250	.100
18-7101	25	305739	.250	.065	18-7146	25	554545	1.120	.100
18-7102	25	307450	.430	.065	18-7150	35	303598	.225	.115
18-7103	25	308624	.924	.103	18-7150	35	331380	.225	.115
18-7104	25	308627	2.210	.135	18-7150	35	334913	.225	.115
18-7105	25	311338	.750	.065	18-7152	25	307082	2.625	.135
18-7107	25	313175	4.750	.135	18-7153	25	911851	.862	.103
18-7108	25	313893	2.550	.100	18-7153	25	3852565	.862	.103
18-7108	25	338518	2.550	.100	18-7155	25	305270	1.620	.135
18-7109	25	317178	.214	.048	18-7156	25	309731	1.185	.100
18-7111	1	301824	.197	.113	18-7158	25	310967	.740	.100
18-7112	1	302493	1.170	.135	18-7158	25	310585	.740	.100
18-7114	2	302540	1.000	.135	18-7162	25	302337	2.025	.135
18-7115	1	302588	1.735	.135	18-7164	25	302537	1.375	.100
18-7116	1	303067	.360	.100	18-7165	25	304174	.500	.065
18-7117	1	303360	1.060	.135	18-7167	25	310414	3.625	.135
18-7118	25	305242	.300	.135	18-7168	25	202893	.370	.065
18-7120	1	307853	.215	.065	18-7169	25	911686	3.500	.135
18-7121	1	308621	3.100	.135	18-7170	25	307239	1.359	.139
18-7123	1	308876	2.235	.100	18-7172	25	553126	3.250	.135
18-7126	1	313340	1.690	.100	18-7173	25	310327	1.875	.135
18-7127	1	313446	3.315	.135	18-7174	25	910582	.620	.100
18-7128	1	313754	1.835	.100	18-7174	25	326649	.620	.100
18-7129	25	314491	.970	.065	18-7178	25	320140	.920	.135
18-7130	1	314728	2.125	.100	18-7180	25	303347	.445	.090
18-7133	25	305123	3.780	.135	18-7198	25	308626	1.430	.100
18-7133	25	322119	3.780	.135	18-7400	25	908194	4.000	.100
18-7134	25	303059	.500	.100	18-7401	25	908383	2.485	.100
18-7135	1	310584	.750	.135	18-7403	25	909316	1.500	.100
18-7137	25	318372	0.320	.155	18-7404	25	909747	.300	.100
18-7138	25	318717	1.500	.210	18-7406	25	911311	0.250	.065
18-7139	25	319085	1.080	.210	18-7407	25	911700	4.125	.135
18-7140	25	320303	2.750	.135	18-7407	5	3852531	4.125	.135
18-7141	25	321117	.180	.065	18-7408	25	911718	1.060	.100
18-7142	2	322119,	3.940	.135	18-7409	25	911871	1.175	.100
18-7143	25	322501,			18-7411	25	321921	1.237	.103
		331188	1.310	.100	18-7413	25	303191	.301	.070
18-7144	25	326849	4.250	.135	18-7416	25	329380	.612	.103
					18-7417	25	329381	.362	.103
					18-7418	25	326741	4.484	.139
					18-7440-1	4	301967	.799	.103
					18-7457	1	319662	1.799	.103
					18-7461	1	308458	1.612	.103
					18-7475	15	332584	.250	.065
					18-7477	25	909048	.480	.100
					18-7510	5	321163	2.750	.070

① PKG. OF 1 ② PKG. OF 5 ③ PKG. OF 10 ④ PKG. OF 2 ■ Indicates quad rings rather than O-Rings
 ⑤ This product is priced per piece. To order priced per package, please add -9 to the part number.

POWERHEAD				
HP	YEAR	O RING	QTY	DESC
5.5	1959	18-7180	1	L C
9.5	1964-73	18-7156	1	U C
18	1957-72	18-7114	1	CCH
18/25	1957-76	18-7164	1	LL C
20/25	① 1977,79-90	18-7174	1	L C
20/25	1990-95	18-7146	1	CCH O
25/35	1957,69-76	18-7114	1	CCH
25/18	1971-76	18-7164	1	U C
25	② 1989-90	18-7123	1	CCH
25	② 1989-90	18-7457	1	U C
25/35	1978	18-7134	1	L C
28	1962-64	18-7164	1	LL C
28/30/35	1976-77,79-90	18-7174	1	L C
28/30/35	1990-95	18-7146	1	CCH O
33/35/40	1957-75	18-7164	1	LL C
35	1987	18-7128	1	U C
35	1987	18-7123	1	CCH
40/45	① 1976,81-95	18-7123	1	CCH
40)	① 1976,81-95	18-7128	1	U C
45/45SS	① 1985-95	18-7128	1	U C
45SS/48	1987-95	18-7123	1	CCH
48/50/55	① 1971-95	18-7128	1	U C
50	1958-59	18-7133	1	CCH
50/55	① 1968-90	18-7123	1	CCH
55/60	1968-71	18-7117	1	CCH O
60/65/75/80	1960-68	18-7133	2	CCH
60/SST60	1970-71,81-95	18-7128	1	U C
60/SST60	1970-95	18-7123	1	CCH
60/SST60	1989-90	18-7158	1	L C
65	① 1972-73,85-95	18-7123	1	CCH
65	① 1972-73,85-95	18-7128	1	U C
65/70	① 1989-90	18-7158	1	L C
70	1974-90	18-7123	1	CCH
70	1974-90	18-7128	1	U C
75	1975-88	18-7128	1	U C
75	1975-88	18-7123	1	CCH
V-4	1969-71	18-7117	1	CCH O
85)	1968-80	18-7133	4	CCH
88/90/100	① 1964,81-95	18-7133	4	CCH
100	1966	18-7120	4	CCHS
110/115	1969-95	18-7133	4	CCH
125/135/140	1971-84	18-7133	4	CCH
150/155/175	① 1977-90	18-7133	4	CCH
200/235/185	1976-85	18-7133	4	CCH

CCH S Crankcase Head Screw
 L C Lower Crankshaft
 LL C Large Lower Crankshaft
 ① Commercial Models Only

CCH O Crankcase Head Outer
 U C Upper Crankshaft
 CCH Crankcase Head
 ② 89 Models DR, DE, DT

POWERHEAD				
HP	YEAR	O RING	QTY	DESC
4	1969-90	18-7111	1	FC
5 THRU 300	① 1957-90	18-7111	2	FC
20/25/30	1984-86	18-7101	1	EPMV
35/40	1984-86	18-7101	1	EPMV
45	① 1986-87	18-7101	1	EPMV
50	1985-86	18-7101	1	EPMV
55	① 1986-88	18-7101	1	EPMV
60/65/70	① 1985-86	18-7101	1	EPMV
75	1983-86	18-7101	1	EPMV
V-4/6	① 1980-86	18-7101	1	EPMV
200/225	1986-88	18-7115	1	EPP
V-8	1985-86	18-7115	1	EPP

① Commercial Models Also
 EPMV Electric Fuel Primer Manual Valve
 FC Fuel Connector
 EPP Electric Primer Pump

POWER TILT AND TRIM				
HP	YEAR	O RING	QTY	DESC
35/40/45	① 1986-89	18-7168	1	LA
45SS	1988-90	18-7134	1	TEC
45SS	1988	18-7141	4	OL
50/55/60	① 1981-89	18-7168	1	LA
60/70/75	1981-90	18-7174	2	MVS,L
60/70/75	1981-90	18-7141	4	OL
60/70/75	1981-90	18-7165	2	MVS,S
60/70/75	1981-90	18-7102	1	FP
70/75	1981	18-7174	1	TR
V-4/6	① 1977-79	18-7168	3	RV
V-4/6	① 1977-90	18-7174	1	TR
V-4/6/8	1977-90	18-7174	2	MVS,L
V-4/6/8	① 1977-90	18-7102	1	FP
V-4/6/8	① 1977-90	18-7165	2	MVS,S
V-4/6/8	① 1977-90	18-7141	4	OL
85	1976-79	18-7168	1	LA
115/135	1974-77	18-7168	1	LA
200	1976	18-7168	3	RV
200/300	1990	18-7168	3	RV

① Commercial Models Also
 TEC Trim End Cap to Rod
 LA Line Assembly
 RV Relief Valve
 MVS,L Manifold Valve Seat, Large
 MVS,S Manifold Valve Seat, Small
 TR Trim rod
 FP Fill Plug
 OL Oil Line

POWER STEERING				
HP	YEAR	O RING	QTY	DESC
60/70/75	1981-90	18-7168	4	CP
V-4/6/8	1980-90	18-7168	4	CP
V-6/8	1986-90	18-7129	2	SC
V-6/8	1986	18-7135	3	PVHT

CP Pump Control Piston
 RV Pump Hsg. Relief Valve
 SV Spoon Valve
 SC Steering Cylinder
 PVHT Piston to Valve Hsg. Tube Seal

DRIVESHAFT HOUSING				
HP	YEAR	O RING	QTY	DESC
2.5	1987-88	18-7101	1	SS
4	③ 1981-90	18-7101	1	SS
4	② 1984,86-90	18-7168	1	K&S
4	④ 1984,86-90	18-7146	2	SB
4.5	1980-84,86-87	18-7168	1	K&S
4.5	1980-87	18-7146	2	SB
4.5	1980	18-7146	1	EHC
5	1984-90	18-7168	1	K&S
5	1984-90	18-7146	2	SB
6	1984-90	18-7168	1	K&S
6	1984-90	18-7146	2	SB
6.5	① 1989-90	18-7168	1	K&S
6.5	① 1989-90	18-7146	2	SB
7.5	1980-83	18-7146	2	SB
7.5	1980-83	18-7168	1	K&S
7.5	1980	18-7146	1	EHC
8	1984-90	18-7146	2	SB
8	1984-90	18-7168	1	K&S
28	1962-64	18-7115	1	SB
33	1965-70	18-7115	1	SB
35	1959	18-7114	1	PS
40	1960-70	18-7102	1	SS
40	1961-70	18-7114	1	PS
40	⑤ 1971-76,81-90	18-7115	1	SB
45SS	1987,88	18-7115	1	SB
60	1964-67	18-7180	4	SA
65	1968	18-7180	4	SA
75	1960-61,64-65	18-7180	4	SA
80	1966-67	18-7180	4	SA

DRIVESHAFT HOUSING (Cont.)					GEARCASE (Cont.)				
HP	YEAR	O RING	QTY	DESC	HP	YEAR	O RING	QTY	DESC
85	1968	18-7180	4	SA	25	⑥ 1989-90	18-7137	1	SR
90	1964-65	18-7180	4	SA	28/33	1962-63,65-67	18-7165	1	WT E
100	1966-68	18-7180	4	SA	28/33	1962-70	18-7134	1	DS CC
① Commercial ② "RD" Models Only ③ "BR" "RL" "RC" "RE" Models Only ④ "R" "RD" Models Only ⑤ '82-'90 Commercial EHC Exhaust Housing Cover					K&S Knob & Shaft to Swivel Bracket PS Pivot Shaft SS Shift Shaft SA Shock Absorber SB Swivel Bracket				
GEARCASE									
HP	YEAR	O RING	QTY	DESC	HP	YEAR	O RING	QTY	DESC
1.5/2	1968-90	18-7173	1	PBH	28/33/35	1962-70	18-7115	1	PBH
2/2.5/4	1988-90	18-7145	1	D&F S	28	1963-64	18-7100	1	SR
3/4	1957-79	18-7168	1	DS CC	28	1987-95	18-7475	1	SR PP
3/4 Std. Gearcase	1964-80	18-7173	1	PBH	30/35/33	1965-70,84-85	18-7120	1	SR PP
4	☆ 1981-95	18-7162	1	PBH	30/33	1965-95	18-7100	1	SR
4 RD Models	1984,86-95	18-7118	1	SR	30/35	1976-86	18-7109	2	PBH S
4.5	1980-87	18-7118	1	SR	30/35	① 1976-95	18-7108	1	PBH
5/5.5	1957-68	18-7180	1	DS BH	30/35	1976-95	18-7105	2	IH S
5	1965-68	18-7173	1	PBH	30/35	① 1983-95	18-7180	1	SR S
5/6/108	1984-95	18-7118	1	SR	30	1984-90	18-7146	1	IH
5/6/6.5/8 6.5 HP Comm	1988-95	18-7145	2	D&F S	30/35	1986-95	18-7475	1	SR PP
5/6/108	1989-95	18-7168	1	WT E	30/35	① 1986-95	18-7100	1	IH
5.5/6	1957-79	18-7100	1	SR	30/35	① 1987-95	18-7145	2	D&F S
5.5/6/7.5	1957-79	18-7117	1	PBH	35	1957-58	18-7165	1	WT E
5.5	1964	18-7120	1	SR PP	35	④ 1957-59,87	18-7134	1	DS CC
6/7.5	1957-79	18-7180	1	DS BH	35/40	⑩ 1957-90	18-7100	1	SR
6	1965-79	18-7120	1	SR PP	35	1976-77	18-7174	1	DS CC
6.5/7.5 7.5 HP Comm	1980-90	18-7118	1	SR	35	⑤ 1983-84,86-90	18-7146	1	IH
6.5 Comm	1989-90	18-7168	1	WT E	35	⑩ 1987	18-7140	1	PBH
7.5/9.5	1957-73	18-7100	1	SR	35	⑩ 1987	18-7137	1	SR
9.5/10	1958-73	18-7117	1	PBH	35	⑩ 1987	18-7115	1	DS BH
9.5	1964-73	18-7120	1	SR PP	35	④ 1987,90	18-7475	1	BS
9.5	1965-66,68,70-73	18-7168	1	WT E	35	④ 1987-90	18-7475	2	PBH S
9.5/9.9/15	1974-84	18-7116	1	DS CC	40	② 1960-85,89-90	18-7115	1	PBH
9.9/15	1974-95	18-7100	1	SR	40/48	1960-88	18-7134	1	DS CC
9.9/15	1974-95	18-7168	1	WT E	40	* 1962-70	18-7152	1	PBH
9.9/15	1974-90	18-7104	1	PBH	40	* 1965-66,71,73-85	18-7120	1	SR PP
9.9/15	1974-90	18-7139	1	IH	40	☆ 1966,70	18-7120	4	PBH S
9.9/15	1984-85	18-7120	1	SR PP	40	1971,73-76,81-85	18-7165	1	WT E
9.9/15	1986-95	18-7475	1	SR PP	40	1984	18-7109	4	PBH S
9.9/15	1988-92	18-7145	2	D&F S	40/45	④ 1984-86	18-7120	1	BS
9.9/15	1993-96	18-4248	2	D&F S	40/48	1984-88	18-7140	1	PBH
10	1957	18-7112	1	PBH	40/48	1984-88	18-7115	1	DS BH
10/14	☆ 1957-63,88-90	18-7100	1	SR	40/45 45 HP Comm	1984-95	18-7137	1	SR
10/18/25	1957-77	18-7116	1	DS CC	40/45 45 HP Comm	1987-95	18-7475	1	BSS
10/14 Comm	1988-90	18-7145	2	D&F S	40/50	④ 1988-95	18-7145	2	D&F S
14 Comm	1988-89	18-7475	1	SR PP	40/48/50	1989-90	18-7109	1	SR PP
15A	1987-90	18-7174	1	WT	40 Comm	1989-90	18-7165	1	WT E
18/25	1957-76	18-7112	1	PBH	40 Comm	1989-90	18-7475	1	SR PP
18/20/25	☆ 1957-95	18-7100	1	SR	40/48/50	1989-95	18-7172	1	PBH
18/20/28	1964-85	18-7120	1	SR PP	40/48/50	1989-95	18-7173	1	DS BH
20/25	1977,85-95	18-7105	2	IH S	45 Comm	1985-88	18-7134	1	IH
20/25	1985-90	18-7146	1	IH	45 Comm	1985-95	18-7128	1	DS BH
20/25	1985-95	18-7180	1	SR S	45 Comm	1985-95	18-7127	1	PBH
20/25	1985-95	18-7108	1	PBH	45/48 45 HP Comm	1987-95	18-7145	2	D&F S
20/25	☆ 1986-95	18-7475	1	SR PP	45SS	1987-90	18-7134	2	DS CC
20/25/30	1987-95	18-7475	2	PBH S	45 Comm	1995	18-7475	4	PBH S
20/25/28	☆ 1988-95	18-7145	2	D&F S	48	1987-88	18-7475	3	PBH S
20/25	1988-95	18-7100	1	IH	48/50	1987-95	18-7475	1	BS
20/30	1990	18-7475	1	BS	48	1987-95	18-7137	1	SR
25	☆ 1969-86	18-7120	1	SR PP	50/60	1958-67	18-7118	1	SR
25	1977	18-7109	2	PBH S	50/60/65	1958-68	18-7174	1	WT E
25	1978	18-7134	1	DS CC	50/55	1958-69	18-7174	1	DS CC
25	1989-95	18-7475	1	BS	50/55/60	1968-71	18-7126	1	DS BH
25	⑥ 1989-90	18-7172	1	PBH	50/55	1968-72	18-7129	1	PS OP
25	⑥ 1989-90	18-7109	1	SR PP	50	1971	18-7100	1	SR
25	⑥ 1989-90	18-7173	1	DS BH	50	⑧ 1971-74,79,81	18-7127	1	PBH
					50	⑨ 1971-81	18-7128	1	DS BH
					50/55/60	1971-84	18-7109	4	PBH S
					50/55	☆ 1971-88	18-7134	1	DS CC
					50	☆ 1973-74	18-7156	2	SA,L
					50	☆ 1973-74	18-7146	1	SA,S
					50/55	☆ 1973-95	18-7137	1	SR
					50	⑧ 1975,79,81,			

GEARCASE (Cont.)					GEARCASE (Cont.)				
HP	YEAR	O RING	QTY	DESC	HP	YEAR	O RING	QTY	DESC
	82-88	18-7115	1	DS BH	V-4	1966-68	18-7118	1	SR
50	⑧ 1975,79,81-88	18-7140	1	PBH	V-4	1966-68	18-7120	1	SR PP
50/60	1981-86	18-7120	1	BSS	80	1967	18-7120	4	PBH S
55	① 1968-69,79-81, 83-95	18-7127	1	PBH	V-4	1968-95	18-7127	1	PBH
55	⑩ 1976-82	18-7140	1	PBH	V-4	1969-72	18-7129	1	PS OP
55	⑩ 1976-82	18-7115	1	DS BH	V-4/6/8	1969-95	18-7130	1	DS BH
55	⑨ 1979-81,83-95	18-7128	1	DS BH	V-4	1971-86	18-7109	4	PBH S
55	⊕ 1981-88	18-7120	1	BS	V-4	1973-74	18-7146	1	SA,S
55 Comm	1988,90-95	18-7475	4	PBH S	V-4	1973-77	18-7156	2	SA,L
55 Comm	1989-95	18-7475	1	BS	V-4/6/8	1973-95	18-7137	1	SR
55 Comm	1989-95	18-7145	2	D&F S	V-4,6,8	1973-90	18-7158	1	DS CC
60 71 "E" Models	1964,66-67, 70-71	18-7120	4	PBH S	V-4	1975-77	18-7178	1	SA,S
60	⑦ 1964-67,80-87	18-7115	1	DS BH	V-4	1981-86	18-7120	1	BS
60/65/75 Std. Gearcase	1964-68	18-7152	1	PBH	V-4/6	1987-95	18-7475	4	PBH S
60	1964-71,86-88	18-7174	1	DS CC	V-4/6/8	1987-95	18-7145	2	D&F S
60 67 Std. Gearcase	1966-67	18-7120	1	SR PP	85/90	1964-68	18-7152	1	PBH
60/65	1968-71	18-7129	1	PS OP	100	1966-68	18-7167	1	PBH
60	⑨ 1970-81,86-95	18-7127	1	PBH	100	⑦ 1984-90	18-7142	1	PBH
60	⑨ 1980-81,86-95	18-7128	1	DS BH	100 Comm	1986-90	18-7475	1	BS
60	1980-85	18-7134	1	DS CC	100 Comm	1987	18-7109	4	PBH S
60	② 1980-87	18-7140	1	PBH	120	1985	18-7142	1	PBH
60/SST60	1980-95	18-7137	1	SR	125	1971	18-7173	1	PBH
60/SST60/					125 Comm	1989-90	18-7142	1	PBH
65 65 HP Comm	1987-95	18-7475	1	BS	125 Comm	1990	18-7174	1	WT
60/SST60/					140	1985,88-90	18-7142	1	PBH
65 65 HP Comm	1987-95	18-7145	2	D&F S	V-6	1976-78	18-7178	1	SA,S
SST60	1989-90	18-7140	1	PBH	V-6	1976-78	18-7156	2	SA,L
SST60	1989-90	18-7174	1	DS CC	V-6	1976-85	18-7109	4	PBH S
60/65/70 65 HP Comm	1989-90	18-7158	1	DS CC	V-6	1976-90	18-7142	1	PBH
SST60	1989-90	18-7115	1	DS BH	V-6	1986	18-7120	1	BS
65/75	1960-68	18-7118	1	SR	155	⑧ 1984,89-90	18-7142	1	PBH
65 Std. Gearcase	1968	18-7120	1	SR PP	155	⑨ 1984-90	18-7144	3	PBH
65 Std. Gearcase	1968	18-7115	1	DS BH	200/225	1987	18-7120	1	BS
65	⊕ 1968-73, 85-88,90	18-7174	1	DS CC	V-8	1985-86	18-7120	1	BS
65	⊕ 1971,73,85-86	18-7109	4	PBH S	V-8	1985-90	18-7144	3	PBH
65	⊕ 1972-73,85-95	18-7127	1	PBH	V-8	1985-90	18-7174	1	WT
65	⊕ 1973,85-95	18-7137	1	SR					
65	⊕ 1973,85-95	18-7128	1	DS BH					
65/70 75 "B" Models	1973-75	18-7156	2	SA,L					
65/70 75 "B" Models	1973-75	18-7146	1	SA,S					
65 Comm	1985-86	18-7120	1	BS					
65/70 65 HP Comm	1988-95	18-7475	4	PBH S					
70/75	1960-65,74-88	18-7174	1	DS CC					
70/75	1974-85	18-7109	4	PBH S					
70/75	1974-95	18-7137	1	SR					
70	⑦ 1974-95	18-7128	1	DS BH					
70	⑦ 1974-95	18-7127	1	PBH					
70 15" Transom	1977-85	18-7115	1	DS BH					
70 15" Transom	1977-85	18-7140	1	PBH					
70	1981-87	18-7120	1	BS					
70	1988-95	18-7475	1	BS					
70	1988-95	18-7145	2	D&F S					
75	1960,63-65	18-7120	4	PBH S					
75	1961-65	18-7174	1	WT E					
75	⑤ 1964-65,75-88	18-7115	1	DS BH					
75	1965	18-7120	1	SR PP					
75	⑥ 1975-87	18-7127	1	PBH					
75 20" Transom	1975-87	18-7128	1	DS BH					
75 15" Transom	1975-88	18-7140	1	PBH					
75	1981-86	18-7120	1	BS					
75	1987-88	18-7475	1	BS					
75	1987-88	18-7145	2	D&F S					
V-4	1964-66,68-70	18-7120	4	PBH S					
V-4	1964-67	18-7174	1	WT E					
V-4	1964-68	18-7115	1	DS BH					
V-4	1964-72	18-7174	1	DS CC					

- ① 35 hp '87 Models RC, RL
- ② '62-'70 w/o Selectric Shift/'89-'90 Comm.
- ③ '65 Std Gearcase/'75-'87 15" Transom
- ④ '76-'87 20" Transom
- ⑤ '77-'85 20" Transom
- ⑥ '79-'81 Electric Start
- ⑦ '79-'81 Rope Start
- ⑧ '79-'81 Rope Start/'82 Comm.
- ⑨ '79-'81 Rope Start/'83-'90 Comm.
- ⑩ '80-'81 Electric Start/'86-'87 — 15" Transom
- ⑪ '80-'81 Rope Start/'86,'87 — 20" Transom
- ⑫ '87 Models AR, AE
- ⑬ '87 Models RC, RL
- ⑭ '89 Models DR, DE, DT
- ⑮ '89 WTLZ, WTXZ Models '90 WTESM, WTXESM Comm.
- ⑯ '89 WTLZ, WTXZ / '90 WTLESM, WTESM Comm.
- ⑰ '89 WTPLY, WTALY, WTPXY, WTAXY, '90 WTPLA, WTALA, WTPXA/Comm.
- ⑱ AR, AE Models
- ☆ B, BR Models
- ⊕ Comm. Models Also
- ★ Electric Start
- * Selectric Shift

- BS Bearing Setscrew
- DS BH Driveshaft Bearing Hsg.
- DS CC Driveshaft to Crankcase
- D & F S Drain & Fill Screw
- WT E 5" Gearcase Extension, Water Tube
- GC 1 Gearcase (11 7/16")
- GC 2 Gearcase (12 7/8")
- GC3 Gearcase (19 1/2")
- IH Impeller Hsg.
- IHS Impeller Hsg. Spacer
- PBH Prop Bearing Hsg.
- PBH S Prop Bearing Hsg. Screw
- PS OP Prop Shaft Oil Pump
- SA,L Shift Assembly, Large
- SA,S Shift Assembly, Small
- SR Shift Rod
- SR PP Shift Rod Pivot Pin
- SR S Shift Rod Scraper
- WT Water Tube



18-5225 SPARK PLUG WIRE KIT
 Kit includes 25 ft Roll of Hypalon Ignition Wire With a Copper Conductor and a Large Assortment of Three Different End Fittings to Fit McCulloch Motors
 Wire available in 100' Spool **18-5226**



18-5226 IGNITION WIRE
Metallic Core
 100' Spool
 7mm Hypalon



18-5153 CONTACT SET
 Replaces: 75101A, 1340135, 36550135



18-5241 CONDENSER
 Replaces: 38850115

HP	Years	Contact Set	Condenser	HP	Years	Contact Set	Condenser
3.6	1953-57	18-5153	—	7.5	1961-68	18-5153 ②	—
6	1960-62	18-5153 ②	—	10	1958	—	18-5241 ②
7.5	1952-87	18-5153 ②	—	25	1959	18-5153 ② ③	—
7.5	1958	18-5153 ② ③	—	30 - 33	1955-56	18-5153 ②	—
7.5	1960	18-5153 ②	—	40	1957-59	18-5153 ② ③	—

② Two Required

③ REPCO Magneto Only

8' LENGTH COMPLETE FUEL LINE ASSEMBLIES

5/16"
FUEL LINE ASSEMBLY

18-8013EP-2 SILVERADO 4000 Premium



*



18-8004EP-1 PRIMER BULB



*

FUEL LINE ASSEMBLY COMPONENTS



8' LENGTH COMPLETE FUEL LINE ASSEMBLIES

3/8"
FUEL LINE ASSEMBLY

18-8015EP-2 SILVERADO 4000 Premium



*



18-8005EP-1 PRIMER BULB



*

FUEL LINE ASSEMBLY COMPONENTS



12' LENGTH COMPLETE FUEL LINE ASSEMBLIES

5/16"
FUEL LINE ASSEMBLY

18-8032EP-2 SILVERADO 4000 Premium



*



18-8004EP-1 PRIMER BULB



*

FUEL LINE ASSEMBLY COMPONENTS



PRIMER BULB ASSEMBLY
 Comes complete with two Hose Clamps



18-7852-1 FUEL WATER SEPARATOR KIT
 Includes:
18-7845 Filter - **18-7853-1** Bracket
18-4256 1/4" (2) Brass Plugs
18-9004 Pipe Sealant with Teflon® is recommended for use on filter bracket fitting threads



FUEL FILTERS
18-7828-1 **18-7830**
 (1/4" Small) (5/16")
18-7829 **18-7831**
 (1/4" Large) (3/8")



18-79989 TRAILERING STICKS
 Fits: Most outboards over 150hp with three ram intrigrel tilt/trim.

Part #	Description
18-8002EP-1	For 1/4" I.D. Hose
18-8004PE-1	For 5/16" I.D. (large capacity bulb)
18-8005EP-1	For 3/8" I.D. (large capacity bulb)

* Tanks and Engines for picture purpose only.