

# CRUSADER MODEL IDENTIFICATION

MODEL C X L X H F L 245 M SERIAL 631254

1<sup>st</sup> Space: **MANUFACTURER**  
C - Crusader

2<sup>nd</sup> Space: **FACTORY FRESHWATER / CLOSED COOLING**  
X-Freshwater Cooled  
(Space Omitted If Raw Water Cooled )

3<sup>rd</sup> Space: **ENGINE ROTATION**  
L - Rotation, Left-Hand from Rear  
R - Rotation, Right-Hand from Rear

4<sup>th</sup> Space: **ENGINE TYPE**  
A = 5.7L (350 CID HO) (GM)  
G = 5.0L (305 CID) (GM)  
Q = 6.0L (364 CID) (GM)  
X = 8.1L (496 CID STD) (GM)  
Z = 8.1L (496 CID HO) (GM)

5<sup>th</sup> Space: **DRIVE MANUFACTURER**  
W - Borg-Warner  
H - Hurth  
T - Walters  
V - Velvet Drive (cast iron units specify 71c or 72c)

6<sup>th</sup> Space: **DRIVE FUNCTION / APPLICATION**  
R - Reverse / Reduction  
V - Vee Drive / Reversed Risers  
F - Full Reversing

7<sup>th</sup> Space: **PROPELLER SHAFT ROTATION**  
L - Left-Hand Rotation  
R - Right-Hand Rotation

8<sup>th</sup> 9<sup>th</sup> 10<sup>th</sup> Spaces: **DRIVE GEAR RATIO OR REDUCTION**  
The drive gear ratio will appear in these spaces which identifies the production gear specs. The example gear number shown is a (2.45:1). If the gear being identified does not have 3 digits, a "0" will appear in 10<sup>th</sup> space.  
Example: ( 2.0:1 ) will appear as 200  
( 1.5:1 ) will appear as 150

**\*MODELS ENDING WITH "000000" IN PLACE OF DRIVE I.D. ARE BOBTAIL ENGINES.**

11<sup>th</sup> Space: **IGNITION / FUEL TYPE USED**  
D - DISTRIBUTOR (Carb)  
E - THROTTLE BODY INJECTION  
M - MULTI-PORT FUEL INJECTION

**\*SERIAL NUMBER I.D.\***  
1<sup>st</sup> DIGIT INDICATES DECADE ENGINE WAS MANUFACTURED ( 5 = 1990, 6 = 2000, 7 = 2010 )  
2<sup>nd</sup> DIGIT INDICATES YEAR ENGINE WAS MANUFACTURED.

① 18-5250D



**18-5250**  
**TUNE-UP KIT**

Part #  
18-5311  
18-5345  
18-5418

—CONTAINS—

Description  
Contact Set  
Condenser  
Rotor

Delco 4 & 6 cyl.



**18-5251**  
**TUNE-UP KIT**

Part #  
18-5314  
18-5338  
18-5404-1

—CONTAINS—

O.E. #  
20117  
12530  
20223

Description  
Contact Set  
Condenser  
Rotor

Mallory 8 cyl. Tall Cap



**18-5252**  
**TUNE-UP KIT**

Part #  
18-5310  
18-5344

—CONTAINS—

Description  
Contact Set  
Condenser  
Rotor

Delco 8 cyl.

**18-5255**  
**TUNE-UP KIT**

Part #  
18-5303  
18-5345  
18-5407

—CONTAINS—

O.E. #  
41058  
41057, 705787  
41059

Description  
Contact Set  
Condenser  
Rotor

Prestolite 8 cyl.

**18-5256**  
**TUNE-UP KIT**

Part #  
18-5314  
18-5338  
18-5411

—CONTAINS—

O.E. #  
20117  
12530  
12531

Description  
Contact Set  
Condenser  
Rotor

Mallory 8 cyl. Flat Cap

① Items ending in "D" are Display Packaged - Regular number is Non-Display

① **18-5258D** Display Package



**18-5258 TUNE-UP KIT**

Part # <b>18-5303</b> <b>18-5347</b> <b>18-5407</b>	—CONTAINS— O.E. # 41058 — 41059	Description Contact Set Condenser Rotor
--	---	--



**18-5259 TUNE-UP KIT**

Part # <b>18-5303</b> <b>18-5347</b> <b>18-5429</b>	—CONTAINS— O.E. # 41058 — —	Description Contact Set Condenser Rotor
--	---	--

① **18-5260D** Display Package



**18-5260 TUNE-UP KIT**

Part # <b>18-5303</b> <b>18-5345</b> <b>18-5403</b>	—CONTAINS— O.E. # 41058 41057, 705787 —	Description Contact Set Condenser Rotor
--	---	--



**18-5266 TUNE-UP KIT**

Fits: Flame Thrower Distributors **18-5481, 18-5482, 18-5483, 18-5477, 18-5478, 18-5479**



**18-5269 TUNE-UP KIT**

Part # <b>18-5311</b> <b>18-5345</b> <b>18-5418</b> <b>18-5386</b>	—CONTAINS— O.E. # 41058 — —	Description Contact Set Condenser Rotor Distributor Cap
--	---	---

GM V-6 — Single Point



**18-5270 TUNE-UP KIT**

Part # <b>18-5310</b> <b>18-5344</b> — <b>18-5384</b>	O.E. # 380543 382125 381711 383587	Description Contact Set Condenser Rotor Distributor Cap
---	--	---

Delco V-8 - Single Point



**18-5271 TUNE-UP KIT**

Part # <b>18-5314</b> <b>18-5338</b> <b>18-5404-1</b> <b>18-5376</b>	—CONTAINS— O.E. # 20117 12530 20223 20222	Description Contact Set Condenser Rotor Distributor Cap
--	--	---

Mallory V-8 Tall Cap — Single Point



**18-5272 TUNE-UP KIT**

Part # <b>18-5314</b> <b>18-5338</b> <b>18-5411</b> <b>18-5375</b>	—CONTAINS— O.E. # 20117 12530 12531 1003317, 12532	Description Contact Set Condenser Rotor Distributor Cap
--	---	---

Mallory V-8 Flat Cap — Single Point - Side



**18-5275 TUNE-UP KIT**

Part # <b>18-5303</b> <b>18-5347</b> <b>18-5403</b> <b>18-5352</b>	—CONTAINS— O.E. # 41058 — 41089, 41074 41076	Description Contact Set Condenser Rotor Distributor Cap
--	---	---

Prestolite V-8 - Single Point - Screw Down Cap



**18-5276 TUNE-UP KIT**

Part # <b>18-5303</b> <b>18-5347</b> <b>18-5403</b> <b>18-5353</b>	—CONTAINS— O.E. # 41058 — 41089, 41074 41069	Description Contact Set Condenser Rotor Distributor Cap
--	---	---

Prestolite V-6 - Single Point - Screw Down Cap

APPLICATION BEGINS ON PAGE 597

Items ending in "D" are Display Packaged - Regular number is Non-Display

**18-5277**  
**TUNE-UP KIT**  
—CONTAINS—  
Part # O.E. # Description  
18-5303 41058 Contact Set  
18-5347 — Condenser  
18-5407 41059 Rotor  
18-5369 41052 Distributor Cap  
Prestolite V-8 - Single Point - Clip Down Cap

**18-5278**  
**TUNE-UP KIT**  
Delco EST - V-6

**18-5279**  
**TUNE-UP KIT**  
Prestolite Electronic - V-8  
—CONTAINS—  
Part # Description O.E. # Qty.  
18-5352 Distributor Cap 392-9766 1  
18-5403 Rotor 392-9089 1

**18-5280**  
**TUNE-UP KIT**  
Delco EST - In-Line 4  
—CONTAINS—  
Part # Description O.E. # Qty.  
18-5361 Distributor Cap 986643 1  
18-5406 Rotor, Delco 986651 1

**18-5281**  
**TUNE-UP KIT**  
Delco EST - V-8  
—CONTAINS—  
Part # Description O.E. # Qty.  
18-5354 Distributor Cap 808483 1

**18-5301**  
**TUNE-UP KIT**  
Replaces:  
Fits: male cap v-8 flamethrower distributors

**18-5302**  
**TUNE-UP KIT**  
Replaces:  
Fits: male cap v-8 flamethrower distributors

**18-5303**  
**CONTACT SET**  
Replaces: 41058

**18-5307**  
**CONTACT SET**  
Replaces: 705788

**18-5310**  
**CONTACT SET**  
Replaces: 12525

**18-5311**  
**CONTACT SET**

**18-5314**  
**CONTACT SET**  
Replaces: 20117

**18-5318**  
**CONTACT SET**  
Replaces: 3000124

**18-5338**  
**CONDENSER**  
Replaces: 12530

**18-5344**  
**CONDENSER**  
Replaces: 12526

**18-5345**  
**CONDENSER**  
Replaces: 41057, 705787

**18-5347**  
**CONDENSER**

**18-5403**  
**ROTOR**  
Replaces: 41089, 41074

APPLICATION BEGINS ON PAGE 597

 <p><b>18-5404-1</b> <b>ROTOR</b> Replaces: 20223</p>	 <p><b>18-5405</b> <b>ROTOR</b> Replaces: 38071 Use with <b>18-5354</b> Distributor Cap Fits: New GM style "Module in Cap" distributors - V-8 application</p>	 <p><b>18-5406</b> <b>ROTOR</b> Use with <b>18-5361</b> Distributor Cap</p>	 <p><b>18-5407</b> <b>ROTOR</b> Replaces: 41059</p>
 <p><b>18-5408</b> <b>ROTOR</b> Use with <b>18-5362</b> Distributor Cap Fits: New GM Style "Module in Cap" Distributors V6 Applications</p>	 <p><b>18-5411</b> <b>ROTOR</b> Replaces: 12531,1003318</p>	 <p><b>18-5418</b> <b>ROTOR</b></p>	 <p><b>18-5300</b> <b>ROTOR</b> Fits: Flamethrower Distributors</p>
 <p><b>18-5420</b> <b>ROTOR</b> Replaces: 3000122</p>	 <p><b>18-5427</b> <b>ROTOR</b> Replaces: 705786</p>	 <p><b>18-5429</b> <b>ROTOR</b></p>	 <p><b>18-5301</b> <b>TUNE-UP KIT</b> Replaces: Fits: Male cap v-8 flamethrower distributors</p>
 <p><b>18-5302</b> <b>TUNE-UP KIT</b> Replaces: Fits: Male cap v-8 flamethrower distributors</p>	 <p><b>18-5352</b> <b>DISTRIBUTOR CAP</b> Replaces: 41076 Prestolite</p>	 <p><b>18-5353</b> <b>DISTRIBUTOR CAP</b> Replaces: 41069 Prestolite</p>	 <p><b>18-5354</b> <b>DISTRIBUTOR CAP</b> Replaces: 38070 Fits: New GM style "Module in Cap" Distributors—V-8 applications Use <b>18-5405</b> Rotor</p>
 <p><b>18-5361</b> <b>DISTRIBUTOR CAP</b> Fits: New GM style "Module in Cap" Distributors — 4 cyl. applications Use <b>18-5406</b> Rotor</p>	 <p><b>18-5362</b> <b>DISTRIBUTOR CAP</b> Fits: New GM Style "Module in Cap" Distributors — V6 Applications Use <b>18-5408</b> Rotor</p>	 <p><b>18-5369</b> <b>DISTRIBUTOR CAP</b> Includes Gasket: <b>18-5399</b> Replaces: 41052 Prestolite</p>	 <p><b>18-5473</b> <b>DISTRIBUTOR CAP</b> Black Distributor Cap with Male Terminals for Flamethrower Distributors</p>



 <p><b>18-5474</b> <b>DISTRIBUTOR CAP</b> Red Distributor Cap with Male Terminals for Flamethrower Distributors</p>	 <p><b>18-5375</b> <b>DISTRIBUTOR CAP</b> Replaces: 12532, 1003317</p>	 <p><b>18-5376</b> <b>DISTRIBUTOR CAP</b> Replaces: 20222</p>	 <p><b>18-5384</b> <b>DISTRIBUTOR CAP</b> Replaces: 12528</p>
--	---	---	--

 <p><b>18-5386</b> <b>DISTRIBUTOR CAP</b></p>	 <p><b>18-5389</b> <b>DISTRIBUTOR CAP</b> Replaces: 3000121</p>	<p>PKG. OF 2</p>  <p><b>18-5399</b> <b>18-5399-9</b> <b>DISTRIBUTOR CAP GASKET</b> Replaces: 41061</p>
--	--	---



## FEATURES

- Senses current levels in the coil and adjusts the dwell to maintain peak energy throughout the entire RPM range.
- Develops, on average, 4 times more available energy between 3000 and 5000 RPM's and twice as much plug voltage as point-type systems.
- Ignition energy is sustained and coil life is increased when peak current level is reached just prior to spark.
- More stable timing.
- Use with [18-5472](#) "Flame Thrower II" Coil for optimum performance

 <p><b>18-5286</b> <b>HI-PERFORMANCE ELECTRONIC CONVERSION KIT</b> Fits: 6 Cylinder Delco Distributors</p>	 <p><b>18-5288</b> <b>HI-PERFORMANCE ELECTRONIC CONVERSION KIT</b> Fits: Most Prestolite V-8 Distributors with snap down cap</p>
---	---

 <p><b>18-5289</b> <b>HI-PERFORMANCE ELECTRONIC CONVERSION KIT</b> Fits: Most Prestolite V-8 Distributors with screw down cap</p>	 <p><b>18-5290</b> <b>HI-PERFORMANCE ELECTRONIC CONVERSION KIT</b> Fits: Most Mallory YL or YD 8 cylinder Distributors with clockwise and counter clockwise rotation</p>
--	---

Priced per Package

APPLICATION BEGINS ON PAGE 597



## FEATURES

- Replaces points & condensers for true solid state ignition.
- Uses standard coil, cap and rotor.
- Easy to install, one-piece, 2-wire hook-up.
- Accurate to within 1/4° timing accuracy 0 to 6000 RPM range.
- Can be used with Flame Thrower Coils **18-5466** & **18-5469**.

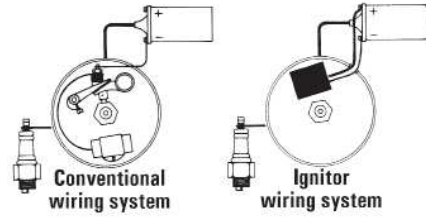

**18-5294**  
**ELECTRONIC CONVERSION KIT**  
Fits: 6 Cyl. Delco distributors



**18-5295**  
**ELECTRONIC CONVERSION KIT**  
Fits: Most 4 Cyl. Prestolite distributors (except IBM 7026)  
For: Onan, Universal, Waukesha, Wisconsin



**18-5296-2D**  
**ELECTRONIC CONVERSION KIT**  
Fits: Most Mallory YL & YD 8 cyl. Distributors with clockwise and counter clockwise rotation



**18-5298**  
**ELECTRONIC CONVERSION KIT**  
With snap down cap  
For: Most Prestolite V-8 Distributors



**18-5299D**  
**ELECTRONIC CONVERSION KIT**  
With screw down cap  
For: Most Prestolite V-8 Distributors  
Use with **18-5403** style rotor



## PREMIUM MARINE SPARK PLUG WIRE LEADS

Sierra's MAGFORCE Ignition Wires are "Electronics Friendly" protecting all of your electronic devices and electronic engine controls from RFI and EMI while delivering the maximum amount of voltage. Exact fit design ensures easy installation and years of trouble - free service.

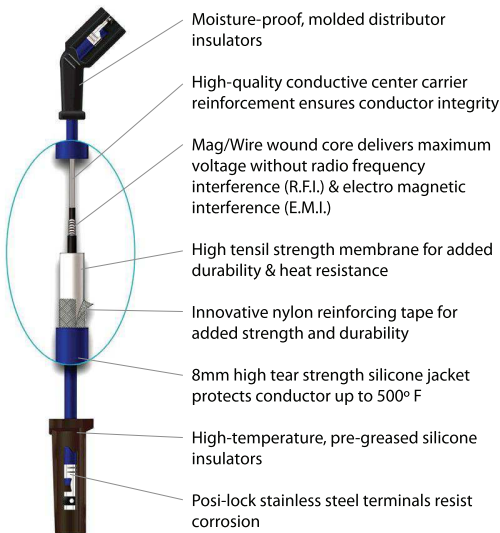

### CRUSADER MARINE IGNITION WIRES APPLICATION

Engine	Cyl.	Distributor	Years	Plug Wire Set
220 (305 CID 5.0L)	8	Mallory/Prestolite ②	1987-1992	<b>18-8803-2</b>
270 (350 CID 5.7L)	8	Mallory/Prestolite ①	Up to 1987	<b>18-8803-2</b>
270 (350 CID 5.7L)	8	Mallory/Prestolite ②	1987-1992	<b>18-8803-2</b>
TB350	8	Delco EST ③	1992 & Up	<b>18-8824-1</b>
5.7L Classic	8	Mallory	1999 & Up	<b>18-8803-2</b>
5.7L MPI Classic	8	Delco HVS	2007 & Up	<b>18-8828-1</b>
MP5.0L Captain's Choice	8	Delco HVS	2002-2005	<b>18-8828-1</b>
MP5.7L Captain's Choice	8	Delco HVS	2002-2005	<b>18-8828-1</b>
MP6.0L	8	Distributorless	2002 & Up	<b>18-8838-1</b>
350 (454 CID 7.4L)	8	Mallory ④	Up to 1991	<b>18-8803-2</b>
454XL (454 CID 7.4L)	8	Delco EST ⑤	1991 & Up	<b>18-8824-1</b>
CM454HO (454 CID 7.4L)	8	Delco EST ⑥	1991 & Up	<b>18-8824-1</b>
454XL (454 CID 7.4L)	8	Delco EST ⑥	1993 & Up	<b>18-8824-1</b>
MP8.1L	8	Distributorless	ALL	<b>18-8838-1</b>
502 (502 CID 8.2L)	8	Prestolite ④	Up to 1991	<b>18-8803-2</b>
502 (502 CID 8.2L)	8	Delco EST ④	Up to 1991	<b>18-8824-1</b>
502XL (502 CID 8.2L)	8	Delco EST ⑤	1991 & Up	<b>18-8824-1</b>
TB502XL (502 CID 8.2L)	8	Delco EST ⑦	1994 & Up	<b>18-8824-1</b>

① Serial Number up to 68702 ② Serial Number 68703-90232 ③ Serial Number 90232 & UP  
④ Serial Number up to 88710 ⑤ Serial Number 88710 & Up ⑥ Serial Number 92882 & Up  
⑦ Serial Number 94268 & Up

### CRUSADER MARINE IGNITION WIRES APPLICATION

Engine	Cyl.	Distributor	Years	Plug Wire Set
262 CID 4.3L	6	Prestolite	ALL	<b>18-8801-1</b>
262 CID 4.3L	6	Delco EST	ALL	<b>18-8810-1</b>
262 CID 4.3L	6	Delco HVS	ALL	<b>18-8829-1</b>
220 (305 CID 5.0L)	8	Mallory/Prestolite ①	Up to 1987	<b>18-8803-2</b>

APPLICATION BEGINS ON PAGE 597

Items ending in "D" are Display Packaged - Regular number is Non-Display



**BATTERY CABLES**  
Gauge cable with soldered lug terminals on each end to accept 3/8" stud.

PART NO.	SIZE	COLOR	GAUGE	PART NO.	SIZE	COLOR	GAUGE
BC88523	2'	red	4	BC88563	6'	red	2
BC88533	2'	black	4	BC88573	6'	black	2
BC88543	4'	red	2	BC88583	8'	red	1
BC88553	4'	black	2	BC88593	8'	black	1



**18-5225 SPARK PLUG WIRE KIT**  
**Replaces:** Mercury 84-99215A26, 84-813706A26  
Kit includes 25 ft. Roll of 7 MM Hypalon Ignition Wire With a Metallic Core and a Large Assortment of Three Different End Fittings.



**18-5226 IGNITION WIRE**  
Metallic Core  
100' Spool • 7mm Hypalon



PKG. OF 10  
**18-5224 SPARK PLUG WIRE TERMINAL**  
**18-5224-9** ①  
**Replaces:** Mercury 20121  
OMC 510364



PKG. OF 10  
**18-5750 UNIVERSAL SPARK PLUG BOOTS**  
**18-5750-9** ①  
Supplied complete w/Terminal Connector  
**Replaces:**  
OMC 581027, 580339



**18-5752 UNIVERSAL SPARK PLUG BOOTS**  
8mm

**FEATURES**

- Distributors feature the Ignitor II ignition module with adaptive dwell control adjusts the spark timing over the entire RPM range to maximize performance
- Upper roller bearing and oil impregnated bronze sintered bottom bushing are installed and aligned bored for accuracy for maximum durability
- Machined heat treated gear with tight tolerances insures durability and consistent timing to maximize horsepower and performance. Complete with high dielectric strength cap and rotor for years of performance

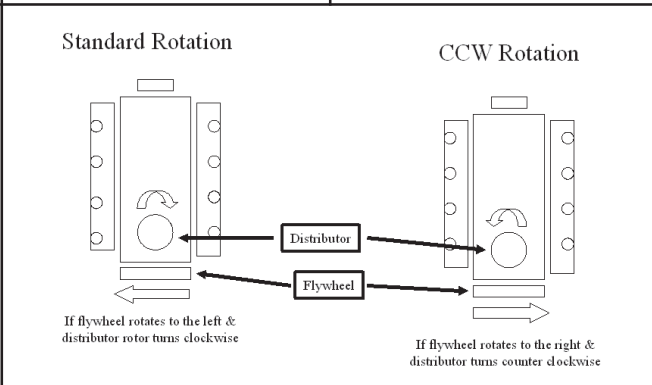

**18-5483 HI-PERFORMANCE ELECTRONIC DISTRIBUTOR**  
**Fits:** Chevrolet Marine Small and Big Block engines (Standard Deck Height)  
Replacement cap/rotor kit **18-5266**



**18-5309-1 DISTRIBUTOR**  
**Replaces:** Mallory YL512CV  
For most Ford 302 CID V-8 Eng.  
Tune-Up Kit **18-5251**

— CONTAINS —

Part # 18-5314 18-5338 18-5404-1	Desc. Contact Set Condenser Rotor
---	--



**18-5313-1 DISTRIBUTOR**  
**Replaces:**  
Crusader 37061  
Mallory YL624MW  
For most GM V-8 Eng. small & large block Mallory Tall Cap  
Tune-Up Kit **18-5251**

— CONTAINS —

Part # 18-5314 18-5338 18-5404-1	Desc. Contact Set Condenser Rotor
---	--



**ELECTRONIC DISTRIBUTORS**  
U.L. Approved

Part No.	Rotation	Application
18-5494-2	Conventional	Chevrolet All V8 (exc. 348,409 & Tall Deck Big Block) Includes 482, 502, 540 CID
18-5495-2	Conventional	Ford V-8, 302 CID

\*Older reverse rotation engines with reverse cut camshaft gear

USES:

Part #	Description	Part #	Description
18-5376	Distributor Cap	18-5488	Module
18-5404-1	Rotor		

① Priced per Package

**18-5484-1  
ELECTRONIC  
DISTRIBUTOR**

**Conventional Rotation**

**Replaces:** RA107039E

Late Model HEI

For V8 — 262-454 & 502 except 384/409 and tall block engines

- Designed as a plug-in replacement for GM-style fuel injection system distributors



—CONTAINS—

Description	Part #
Distributor Cap	18-5354
Rotor	18-5405

**18-5480  
COMPLETE IGNITION  
CONVERSION KIT**

**Fits:** GM SB & BB with Standard Deck Height



—CONTAINS—	
Part #	Description
18-5472	Coil
18-8803-2	Wire Set
18-5483	Distributor

**18-26812  
HEI COIL GRAY CONNECTOR**



**18-26813  
HEI COIL BLACK CONNECTOR**



**18-5108  
PICKUP COIL  
SENSOR**



**18-5464  
IGNITION MODULE**  
Fits: Sierra 18-5481, 18-5482 and 18-5483 Billet HI-PERFORMANCE ELECTRONIC DISTRIBUTORS (except HEI/EST)



**18-5107-1  
IGNITION MODULE**  
4/6/8 cyl.  
**Replaces:** 7243110



**18-26810  
GM HEI 4 TERMINAL  
PIGTAIL**  
Fits: GM HEI Distributors w/4 terminals



**18-26811  
GM HEI 2 TERMINAL  
PIGTAIL**  
Fits: GM HEI Distributors w/2 terminals

**FEATURES**

- Oil filled for better cooling and long life
- Low resistance and improved turn ratios produces the higher voltage needed to run larger spark plug gaps for added power and better fuel economy
- More windings maximize energy and reliability over the full RPM range
- Fits existing brackets for easy installation

**18-5466  
HI-PERFORMANCE  
IGNITION COIL**

1.5 ohm (oil filled), black - 8 cylinder: Flame-Thrower 40,000 volt coil.  
★ Designed for use with the original Ignitor Electronic Conversion Kits  
★ Can be used with other inductive ignition systems



**18-5469  
HI-PERFORMANCE  
IGNITION COIL**

3.0 ohm (oil filled), black - 4 & 6 cylinder: Flame-Thrower 40,000 volt coil.  
★ Designed for use with the original Ignitor Electronic Conversion Kits  
★ Can be used with other inductive ignition systems



**18-5472  
HI-PERFORMANCE  
IGNITION COIL**

0.6 ohm (oil filled), black - 4, 6, & 8 cylinder: Flame-Thrower 45,000 volt coil.  
★ Super low 0.6 ohm resistance coil designed for use with the Ignitor II Hi Performance Electronic Conversion Kits  
★ Compatible with capacitive discharge systems



Part #	Description	Recommended Coil	Resistance Ohms	Part #	Description	Recommended Coil	Resistance Ohms
18-5294	Electronic Conversion Kit	18-5469	3.0	18-5286	Hi Performance Electronic Conversion Kit	18-5472	0.6
18-5295	Electronic Conversion Kit	18-5469	3.0	18-5288	Hi Performance Electronic Conversion Kit	18-5472	0.6
18-5296-2	Electronic Conversion Kit	18-5466	1.5	18-5289	Hi Performance Electronic Conversion Kit	18-5472	0.6
18-5298	Electronic Conversion Kit	18-5466	1.5	18-5290	Hi Performance Electronic Conversion Kit	18-5472	0.6
18-5299	Electronic Conversion Kit	18-5466	1.5	18-5483	Flame-Thrower Distributor	18-5472	0.6

**18-5433  
IGNITION COIL**

**Replaces:** 37068, 51080  
Uses External Resistor



**18-5435  
IGNITION COIL  
4.0 OHM**

**Replaces:** 41080  
Has Internal Resistor



**18-5436  
IGNITION COIL  
3.0 OHM**

Has Internal Resistor  
(For Mallory Applications)



**18-5438  
IGNITION COIL**

**Replaces:** 37068  
HEI



**18-5443  
IGNITION COIL**

**Replaces:** 7243200  
4cyl./V-8  
For: 3.0L (1991 & up) 5.7 & 7.4 EFI (1995 & up)



**18-5450  
COIL RESISTOR  
1.5 OHM**



**18-5493  
IGNITION PICKUP  
COIL ASSEMBLY**

Replacement pick-up coil for Accel Electronic Distributors





## IGNITION / ELECTRICAL SYSTEMS APPLICATION

Cyl.	Model Engine	Year	Distributor No.	Contact Set	Condenser	Rotor	Dist. Cap	Tune-Up Kit	Distributor	Elect. Con. Kit
4	153	1961-69	YL486C,D ④	18-5314	18-5338	18-5427	—	—	—	—
4	IH60,M60, PH45,134	1971-75	IAY4010A	18-5307	18-5345 ⑤	18-5427	—	—	—	—
6	230,292 Chevy	1961-69	YL486A,B ④	18-5314	18-5338	18-5427	—	—	—	—
6	229,3.8L	1980-82	IBM7014,A	18-5303	18-5345 ⑤	18-5403	18-5353	18-5260, 18-5276 ⑥	—	—
6	229,262	1983-88	IBM7018	18-5303	18-5345 ⑤	18-5403	18-5353	18-5260	—	—
6	229,262	1983-88	IBM7021	18-5303	18-5345 ⑤	18-5403	18-5353	18-5260, 18-5276 ⑥	—	—
8	185,230, 250, 280	1962	IBM4110	18-5303	18-5345 ⑤	18-5429	—	18-5259	—	—
8	283,327,348	1961-69	YL487A	18-5314	18-5338	18-5404-1	18-5376	18-5251, 18-5271 ⑥	18-5494-2 ① 18-5498-1 ② 18-5313-1 ③	18-5296
8	185,220,230	1961-69	ZD431A, YL431A ④	18-5314	18-5338	18-5411	18-5375	18-5256	—	—
8	170,220,225HP, 275CAD	1961-69	ZD345A,B, ZD345A,B	18-5314	18-5338	18-5404-1	18-5376	18-5251, 18-5271 ⑥	18-5494-2 ① 18-5498-1 ② 18-5313-1 ③	18-5296
8	283,327,409,427	1965-71	1111161	18-5310	18-5344	—	18-5384	18-5252, 18-5270 ⑥	18-5494-2 ① 18-5498-1 ② 18-5313-1 ③	18-5296
8	302,351	1971-75	—	18-5318	—	18-5420	18-5389	—	18-5495-2 ① 18-5309-1 ③	—
8	302	1975-78	IBM7007,A	18-5303	18-5345 ⑤	18-5407	18-5369	18-5258, 18-5277 ⑥	18-5495-2 ① 18-5309-1 ③	18-5298
8	305,350,454	1977-82	IBM7011,D	18-5303	18-5345 ⑤	18-5407	18-5369	18-5258, 18-5277 ⑥	18-5495-2 ① 18-5309-1 ③	18-5298
8	305,350,454	1977-82	IBM7013	18-5303	18-5345 ⑤	18-5403	18-5352	18-5260, 18-5275 ⑥	18-5494-2 ① 18-5498-1 ② 18-5313-1 ③	18-5299
8	305,350,454	1983-87	Mallory	18-5314	18-5338	18-5404-1	18-5376	18-5251, 18-5271 ⑥	18-5494-2 ① 18-5498-1 ② 18-5313-1 ③	18-5296
8	ALL	1987-88	IDU7801B,C B.I.D.Elec. Ign.	N/A	N/A	18-5403	18-5352	N/A	—	—

① Electronic Distributor (Standard Rotation)  
② Electronic Distributor (Counter Rotation)

③ Contact Controlled Distributor (Standard Rotation)  
④ Mallory Ignition Only

⑤ For Strap Type Condenser, use **18-5347**  
⑥ Tune-Up Kit with Distributor Cap



**18-5907  
STARTER**  
(Heavy Duty) (No Core) Clockwise  
Top Mount Rear Entry Starter  
Will not replace non-starter mounted solenoids.  
For: Opposite Rotation GM & Ford Engines.  
Replaces: 42090  
Replacement Solenoid: **18-5837**  
SAEJ1171

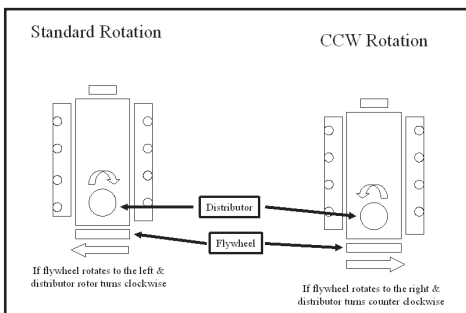

**18-5908  
STARTER**  
(Heavy Duty) (No Core)  
Counter-Clockwise  
Top Mount Rear Entry Starter  
For: Standard Rotation GM & Ford Engines.  
Replaces: 42091  
Replacement Solenoid: **18-5837**  
SAEJ1171

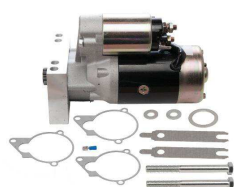

**18-6835  
STARTER**  
Replaces: GM Engines Universal  
Used on all GM Engines with either 14 1/4" or  
12 3/4" flywheels

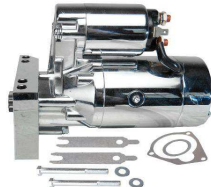

**18-6834  
STARTER**  
Replaces: GM Engines Universal  
Used on all GM Engines with either 14 1/4" or  
12 3/4" flywheels



**18-9802  
TIMING LIGHT**  
Self-powered accurate  
up to 10,000 RPM's



**18-15214  
RELAY, SHROUDED**  
Replaces: R130012  
For: Fuel Pump on Crusader MEFI  
systems

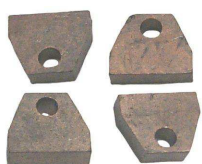

**18-5717  
STARTER BRUSH SET**  
Replaces: 42001, 707125  
Delco



**18-5838  
SOLENOID**  
Delco







**18-5840  
SOLENOID**  
Prestolite 15-79,  
SAW4201, SAW4207,  
SAW4210











**18-2434  
FLYWHEEL  
BELL HOUSING**  
Replaces: 96938

**BRUSH SET / STARTER SWITCH APPLICATION**

Year	Voltage	Original Starter No.	Brush Set	Starter Switch
1960-75	12	MDU-7015, 16	—	18-5840
1975-81	12	MEO-7044, 05	—	18-5840
1972-UP	12	96077, 96078 42031, 420036 1107710, 54, 63, 889	18-5717	18-5838
 <b>18-5710</b> <b>VOLTAGE REGULATOR</b> Prestolite VSH-6201JY	PKG. OF 8  <b>FREEZE PLUGS</b> <b>18-5961</b> <b>18-5961-9</b> ① 1 5/8" <b>18-5962</b> <b>18-5962-9</b> ① 1 3/4"	 <b>18-7600</b> <b>TEMPERATURE SENSOR</b> Replaces: 47002	 <b>18-7630</b> <b>THROTTLE POSITION SENSOR</b> Replaces: 47032	 <b>18-7632-1</b> <b>IDLE AIR CONTROL MOTOR</b> Replaces: 47033

**VOLTAGE REGULATOR APPLICATION**

Year	Model	Voltage	Original Alt./Gen. No.	Voltage Regulator
1966-75	Conqueror 190, 220, 250, 320	12	ALE-5204,S	18-5710
1966-75	150, 165, 185, 190, 230, 250, 280, 320	12	ALF-5201-1, A-1,S	—
		12	ALE-5202,S	—
		12	ALK-6204A	—
		12	ALE-5204,S	18-5710

 <b>18-7607-1</b> <b>CARBURETOR (REMANUFACTURED)</b> Replaces: Rochester 17082403 For: Rochester Carb: Crusader 454	 <b>18-7019</b> <b>CARB KIT</b>	 <b>18-7022</b> <b>CARB KIT</b>
 <b>18-7070</b> <b>CARB KIT</b>	 <b>18-7072</b> <b>CARB KIT</b>	 <b>18-7078</b> <b>CARB KIT</b>
 <b>18-7086</b> <b>CARB KIT</b>	 <b>18-7095</b> <b>CARB KIT</b> Replaces: 45334	 <b>18-7725</b> <b>CARB KIT</b>

① Priced per Package

**CARBURETOR KIT APPLICATION ON NEXT PAGE**



**18-7200**  
**FLOAT**  
Replaces: 45303  
(Alcohol Resistant)  
Plastic

**18-7201**  
**FLOAT**  
(Alcohol Resistant)  
Brass

**18-7202**  
**FLOAT**  
(Alcohol Resistant)  
Brass

**CARBURETOR KIT AND FLOAT APPLICATION**

Cyl.	Model or Eng. Displacement	Mfg. Code	Carb. Model	Carburetor Number	Carb. Kit ①	Float
4	153" (2.5L)	R-2	2GC	7025082, 7028086	18-7070	18-7200
6	225" (3.7L)	R-2	2GC	7025181	18-7070	—
8	283" (4.6L), 327 (5.3L)	R-2	2GC	7024185	18-7070	—
8	283" (4.6L)	C-1	YH	2618, 2912	18-7725	—
8	305" (5.0L)	R-2	2GV	17057134	18-7086	18-7202
8	327" (5.3L), 409 (6.6L)	R-4	4GC	7020084, 085	18-7019	—
8	327" (5.3L), 409 (6.6L)	R-4	4GC	7023084, 085, 089	18-7078	—
8	348" (5.7L)	C-4	AFB	2955	18-7022	—
8	350" (5.7L), 454 (7.4L)	R-4	4MV	17059293, 17082403	18-7095	18-7201
8	427" (7.0L)	R-4	4MV	7027081, 7028282	18-7072	18-7201

① Does Not Include Metering Rods

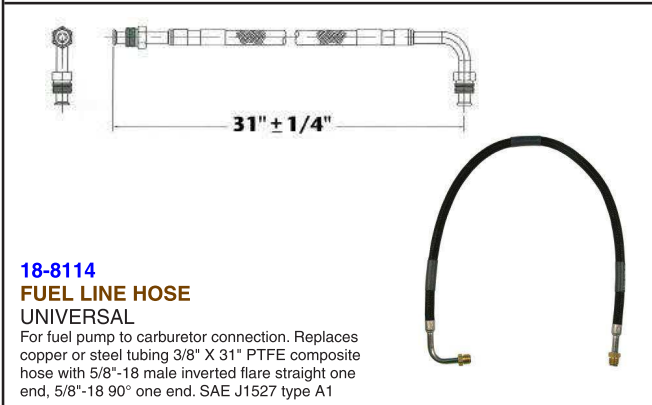

**18-8114**  
**FUEL LINE HOSE**  
UNIVERSAL  
For fuel pump to carburetor connection. Replaces copper or steel tubing 3/8" X 31" PTFE composite hose with 5/8"-18 male inverted flare straight one end, 5/8"-18 90° one end. SAE J1527 type A1

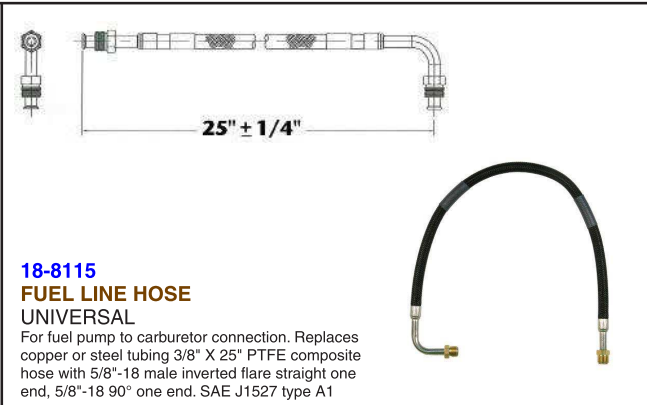

**18-8115**  
**FUEL LINE HOSE**  
UNIVERSAL  
For fuel pump to carburetor connection. Replaces copper or steel tubing 3/8" X 25" PTFE composite hose with 5/8"-18 male inverted flare straight one end, 5/8"-18 90° one end. SAE J1527 type A1



**18-7231**  
**FLAME ARRESTOR**  
Replaces: 97595, 97214  
V-8



**18-7232**  
**FLAME ARRESTOR**  
Replaces: 33628  
Hi-Performance



**18-7256**  
**FUEL PUMP**  
Replaces: 32722  
(Flange I.D. #6790, M3530)  
For: GM (4 & 6 Cyl.) 153, 230, 250, 292



**18-7260**  
**FUEL PUMP**  
(Flange I.D. #40155)  
For: GM (V-8) 283, 307, 327, 350, 409



**18-7267**  
**FUEL PUMP**  
(Flange I.D. #41414)  
For: Ford (V-8) 302



**18-7268**  
**FUEL PUMP**  
(Flange I.D. #41415, M6948)  
For: GM (V-8) 305, 307, 350, 400  
(5.25 - 6.5 PSI)  
Dual Diaphragm - Requires Sight Glass

**18-7270**  
**FUEL PUMP**  
 (Flange I.D. #41417, M73019)  
 For: GM (V-8) 305, 350, 400  
 (5.75 - 7 PSI)  
**Replaces:** 21140  
 (Gasket included)



**18-7272**  
**FUEL PUMP**  
 (Flange I.D. #41419, M73020)  
 For: GM (V-8) 283, 305, 350, 400  
 (5.75 - 6.5 PSI)  
**Replaces:** 97039



**FUEL WATER SEPARATORS**



Sierra offers a complete line of 10 and 21 micron fuel water separating filters including drainable bowl filters to protect your carbureted and fuel injected engine.

**Refer to pages 136-140 for a complete listing of OEM and universal applications.**

Sierra fuel water separators remove over 99.8% of emulsified water from your gasoline. Sierra's 10 micron filters are over 90% efficient at removing particles as small as 10 micron. All filters flow @ 90 GPH to feed even the hungriest motor. Sierra 10 micron filters are recommended to prevent damage to sensitive inboard and outboard fuel injection systems.

Sierra #	Crusader #	Description
18-7976	23250	Fuel Filter with O-Rings
18-7852-1	22687	Fuel Water Separator Kit
18-7846	98041	Fuel Filter
18-7862	91606	Fuel Filter
18-7964-1		Fuel Filter
18-7717		Fuel Element (For: Rochester 2bbl & 4bbl Carburetors)
18-7958	47047	Fuel Element (110 Series Filter, 10 Micron)



**18-3060**  
**IMPELLER**  
**Replaces:** 1003026, 22212  
 For: Ford

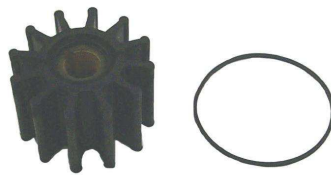

**18-3061**  
**IMPELLER**  
**Replaces:** 20300  
 For: GM engines with V-Belt



**18-8926**  
**IMPELLER**  
**Replaces:** RP061022  
**Fits:** Crusader 5.7 & 6.0L w/ Serpentine Belt

PKG. OF 2



**18-3140**  
**18-3140-9**  
**WATER PUMP GASKET**  
**Replaces:** 20502  
 For: Early 262, 305, 350  
 (ID) 454, 502

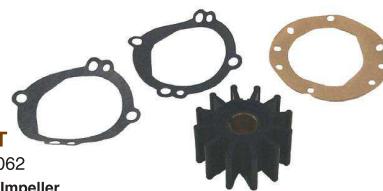







**18-3046**  
**IMPELLER KIT**  
**Replaces:** 1003062  
**Contains:** 18-3060 Impeller  
**Diameter** 2 7/16" • **Side Width** 1 1/4"  
 Use with Sherwood Pumps

① 18-3046D



① Priced per Package

																																
<p><b>18-3047</b> <b>IMPELLER KIT</b> Includes <b>18-3061</b> impeller</p>	<p><b>18-3577-2</b> <b>CIRCULATING WATER PUMP</b> (Bi-Directional) <b>Replaces:</b> 67859, 17670, 811573, 30103 <b>For:</b> Big block GM engines with stamped steel timing covers</p>	<p><b>18-3599-2</b> <b>CIRCULATING WATER PUMP</b> <b>Replaces:</b> 20318, 7142520 <b>For:</b> GM V-6 &amp; small block V-8 engines Uses gasket <b>18-0981</b> (included)</p>																														
																																
<p><b>18-3584</b> <b>CIRCULATING WATER PUMP</b> (Bi-Directional)</p>	<p><b>18-3168</b> <b>SEAL &amp; SEAT ASSEMBLY</b> <b>Replaces:</b> 20309</p>	<p><b>18-3169</b> <b>SEAL &amp; SEAT ASSEMBLY</b> <b>Replaces:</b> 40057</p>																														
																																
<p><b>18-3551</b> <b>THERMOSTAT</b> <b>Replaces:</b> 96319 <b>142°</b> <b>For:</b></p> <table border="1" style="width: 100%; border-collapse: collapse;"> <thead> <tr> <th>Model No.</th> <th>Cubic Inch</th> </tr> </thead> <tbody> <tr><td>CH190</td><td>305</td></tr> <tr><td>CH220</td><td>305</td></tr> <tr><td>CH270</td><td>350</td></tr> <tr><td>CH350</td><td>454</td></tr> </tbody> </table>	Model No.	Cubic Inch	CH190	305	CH220	305	CH270	350	CH350	454	<p><b>18-3552</b> <b>THERMOSTAT</b> <b>Replaces:</b> 96358 Fresh Water Cooling Only <b>160°</b> <b>For:</b></p> <table border="1" style="width: 100%; border-collapse: collapse;"> <thead> <tr> <th>Model No.</th> <th>Cubic Inch</th> </tr> </thead> <tbody> <tr><td>165</td><td>229</td></tr> <tr><td>CH190/CH220</td><td>305</td></tr> <tr><td>CH270</td><td>350</td></tr> <tr><td>CH350</td><td>454</td></tr> </tbody> </table>	Model No.	Cubic Inch	165	229	CH190/CH220	305	CH270	350	CH350	454	<p><b>18-3671D</b> <span style="border: 1px solid blue; border-radius: 50%; padding: 2px;">Display Package</span> <b>18-3671</b> <b>THERMOSTAT KIT</b> <b>Replaces:</b> 97361 Includes Thermostat <b>18-3551</b> and <b>18-0875</b> Gasket <b>142°</b> <b>FOR:</b></p> <table border="1" style="width: 100%; border-collapse: collapse;"> <thead> <tr> <th>Model No.</th> <th>Cubic Inch</th> </tr> </thead> <tbody> <tr><td>CH190</td><td>305</td></tr> <tr><td>CH220</td><td>305</td></tr> <tr><td>CH270</td><td>350</td></tr> <tr><td>CH350</td><td>454</td></tr> </tbody> </table>	Model No.	Cubic Inch	CH190	305	CH220	305	CH270	350	CH350	454
Model No.	Cubic Inch																															
CH190	305																															
CH220	305																															
CH270	350																															
CH350	454																															
Model No.	Cubic Inch																															
165	229																															
CH190/CH220	305																															
CH270	350																															
CH350	454																															
Model No.	Cubic Inch																															
CH190	305																															
CH220	305																															
CH270	350																															
CH350	454																															
																																
<p><b>18-3649</b> <b>THERMOSTAT</b> <b>Replaces:</b> 97895 <b>16°</b> Fresh Water Cooling Use with <b>18-2917</b> Gasket</p>	<p><b>18-5898</b> <b>SENDER</b> <b>Replaces:</b> 700427 <b>1/2" — 14 NPT</b></p>	<p><b>18-5899</b> <b>OIL PRESSURE SENDER</b> <b>Replaces:</b> 700425</p>																														
																																
<p><b>18-4456D</b> <span style="border: 1px solid blue; border-radius: 50%; padding: 2px;">Display Package</span> <b>18-4456</b> <b>EXHAUST PROTECTOR VALVE</b> Includes Stainless Steel Clamp <b>3"</b></p>	<p><b>18-4457D</b> <span style="border: 1px solid blue; border-radius: 50%; padding: 2px;">Display Package</span> <b>18-4457</b> <b>EXHAUST PROTECTOR VALVE</b> Includes Stainless Steel Clamp <b>4"</b></p>	<p><b>18-4458D</b> <span style="border: 1px solid blue; border-radius: 50%; padding: 2px;">Display Package</span> <b>18-4458</b> <b>EXHAUST PROTECTOR VALVE</b> Includes Stainless Steel Clamp <b>5" &amp; 6"</b> (5" requires two 45° cuts)</p>																														

① Items ending in "D" are Display Packaged - Regular number is Non-Display

**Fits GM Big Block V8 454 cu. in.  
Models CH350 & 454XL**

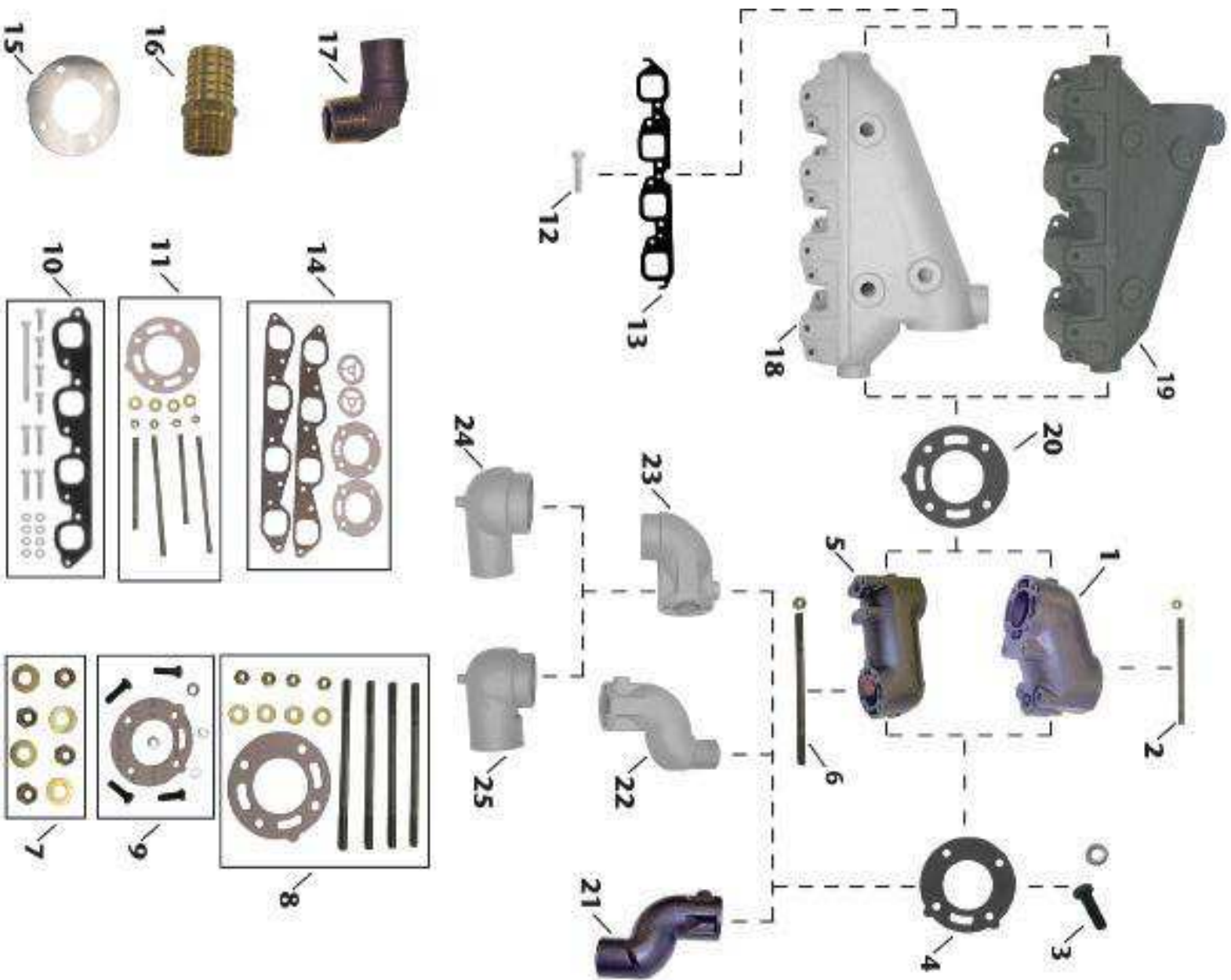

Item No.	Description	OE No.	Application
1	<a href="#">18-1927</a> 4" RISER	97772	Use with Manifolds: <a href="#">18-1933</a> , & <a href="#">18-1929</a> ; Elbow Gasket: <a href="#">18-0309-1</a> ; Mounting Kit: <a href="#">18-8523</a>
2	NSS MOUNTING HARDWARE	N/A	Included in <a href="#">18-8523</a> mounting kit.
3	NSS MOUNTING HARDWARE	N/A	Included in <a href="#">18-8515</a> mounting kit.
4	<a href="#">18-0309-1</a> ELBOW GASKET	96562	Use with Exhaust Elbow: <a href="#">18-1928</a> , <a href="#">18-1934</a> , & <a href="#">18-1918</a>
5	<a href="#">18-1916</a> 8" RISER	97169	Use with Manifolds: <a href="#">18-1933</a> , & <a href="#">18-1929</a> ; Elbow Gasket: <a href="#">18-0309-1</a> ; Mounting Kit: <a href="#">18-8519</a>
6	NSS MOUNTING HARDWARE	N/A	Included in <a href="#">18-8519</a> mounting kit.
7	NSS WASHER & NUT KIT	N/A	Used in mounting kits: <a href="#">18-8515</a> , <a href="#">18-8523</a> , & <a href="#">18-8519</a>
8	<a href="#">18-8519</a> MOUNTING KIT	N/A	Use with Riser: <a href="#">18-1916</a>
9	<a href="#">18-8515</a> MOUNTING KIT	N/A	Use with Elbows: <a href="#">18-1934</a> , <a href="#">18-1928</a> , <a href="#">18-1918</a>
10	<a href="#">18-8524</a> MOUNTING KIT	N/A	Use with Manifolds: <a href="#">18-1929</a> & <a href="#">18-1933</a>
11	<a href="#">18-8523</a> MOUNTING KIT	N/A	Use with Riser: <a href="#">18-1927</a>
12	NSS MOUNTING BOLT	N/A	Included in <a href="#">18-8524</a> mounting kit.
13	<a href="#">18-0418</a> MANIFOLD GASKET	96653	Use with Manifold: <a href="#">18-1929</a> , <a href="#">18-1933</a>
14	<a href="#">18-0601</a> EXHAUST MANIFOLD GASKET SET	N/A	For: "CH" Model Big Block (V8) Chevy 454 CID (7.4L); Use with Manifolds: <a href="#">18-1929</a> , & <a href="#">18-1933</a>
15	<a href="#">18-1917</a> BLOCK OFF PLATE (STAIN-LESS)	97296	Use with Elbow/Riser Gasket: <a href="#">18-0309-1</a> , <a href="#">18-0305-1</a>
16	<a href="#">18-4461</a> HOSE FITTING	N/A	3/4" - 14NPT X 1" Hose (Corrosion Resistant Brass Fitting)
17	<a href="#">18-8112</a> HOSE FITTING	97296; 97854	90 degree fitting. Thread Size: 1" NPT X 1 1/4" Hose Barb
18	<a href="#">18-1929</a> MANIFOLD (STARBOARD)	97992, 97114	GM Big Block (V8) 454 cu.in. (Models CH350 & 454XL)(Starboard); Use with Manifold Gasket: <a href="#">18-0418</a> ; Mounting Kit: <a href="#">18-8524</a>
19	<a href="#">18-1933</a> MANIFOLD (PORT)	97993, 97115	GM Big Block (V8) 454 cu.in. (Models CH350 & 454XL)(Port); Use with Manifold Gasket: <a href="#">18-0418</a> ; Mounting Kit: <a href="#">18-8524</a>
20	<a href="#">18-0305-1</a> ELBOW GASKET	96108	Use with Exhaust Manifold: <a href="#">18-1929</a> , & <a href="#">18-1933</a> . Included in <a href="#">18-8515</a> mounting kit.
21	<a href="#">18-1928</a> ELBOW W/ 4" OUTLET	97924	Use with Riser: <a href="#">18-1927</a> or <a href="#">18-1916</a> ; Elbow Gasket: <a href="#">18-0309-1</a> ; Mounting Kit: <a href="#">18-8515</a>
22	<a href="#">18-1934</a> ELBOW W/ 3" OUTLET	98068	Use with Riser: <a href="#">18-1927</a> or <a href="#">18-1916</a> ; Elbow Gasket: <a href="#">18-0309-1</a> ; Mounting Kit: <a href="#">18-8515</a>
23	<a href="#">18-1918</a> ELBOW W/ 2 1/2" INLET	97386	Use with Riser: <a href="#">18-1927</a> or <a href="#">18-1916</a> ; Elbow Gasket: <a href="#">18-0309-1</a> ; Mounting Kit: <a href="#">18-8515</a>
24	<a href="#">18-1919</a> RE-DIRECTION ELBOW W/ 3" OUTLET	97387	Use with Elbow: <a href="#">18-1918</a>
25	<a href="#">18-1924</a> RE-DIRECTION ELBOW W/ 4" OUTLET	97624	Use with Elbow: <a href="#">18-1918</a>



**Fits GM Big Block V8 454 cu. in.  
Models 454XL & 502XL**

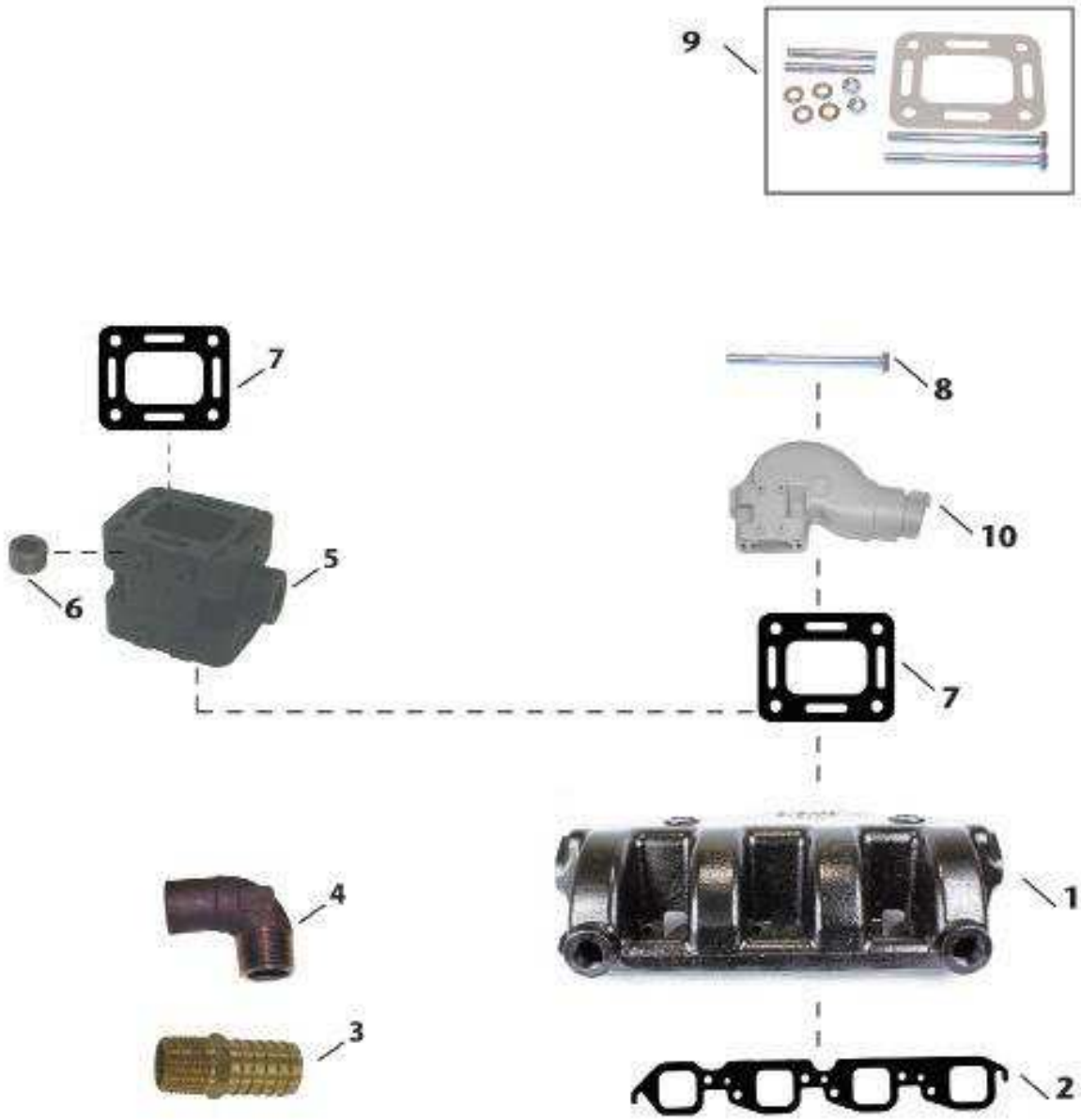

Item No.	Description	OE No.	Application
1	<a href="#">18-1982</a> MANIFOLD	98125	GM Big Block (V8) 454-502 cu.in. (Port & Starboard); Use with Manifold Gasket: <a href="#">18-0418</a>
2	<a href="#">18-0418</a> MANIFOLD GASKET	96653	Use with Manifold: <a href="#">18-1982</a> .
3	<a href="#">18-4461</a> HOSE FITTING	N/A	3/4" - 14NPT X 1" Hose (Corrosion Resistant Brass Fitting)
4	<a href="#">18-8112</a> HOSE FITTING	97296; 97854	90 degree fitting. Thread Size: 1" NPT X 1 1/4"
5	<a href="#">18-1984</a> MANIFOLD SPACER	98128	Use with Elbow Gasket: <a href="#">18-0475-1</a>
6	<a href="#">18-4258</a> BLACKSTEEL PLUG	113186	Thread Size: 3/4" NPT X 1". Use with Spacer: <a href="#">18-1984</a>
7	<a href="#">18-0475-1</a> ELBOW GASKET (OPEN)	98127	Open gasket for universal elbow; Use with Riser: <a href="#">18-1938</a>
8	NSS MOUNTING BOLT	N/A	Included in <a href="#">18-8547</a> mounting kit.
9	<a href="#">18-8547</a> MOUNTING KIT	N/A	Use with Riser: <a href="#">18-1938</a> . Includes <a href="#">18-0475-1</a> gasket.
10	<a href="#">18-1938</a> RISER	98126	Use with Manifold: <a href="#">18-1982</a> ; Riser Gasket: <a href="#">18-0475-1</a> ; Mounting Kit <a href="#">18-8547</a>



### Fits GM Small Block V8 305-350 cu. in. Models 220 & 270

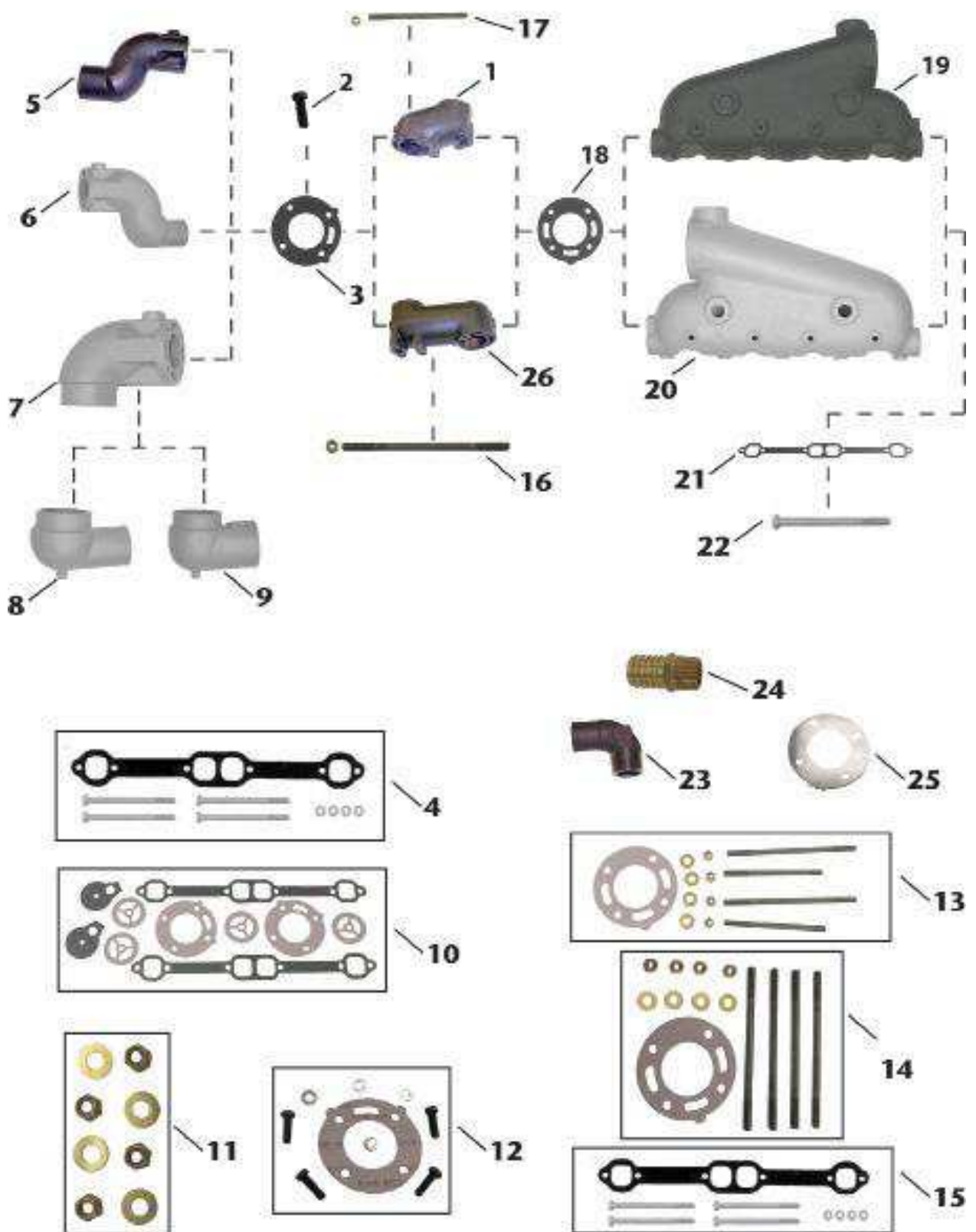

SEE NEXT PAGE FOR APPLICATION CHART

Item No.	Description	OE No.	Application
1	<a href="#">18-1927</a> 4" RISER	97772	Use with Manifold: <a href="#">18-1925</a> , <a href="#">18-1926</a> , <a href="#">18-1933</a> , & <a href="#">18-1929</a> ; Elbow Gasket: <a href="#">18-0309-1</a> ; Mounting Kit: <a href="#">18-8523</a>
2	NSS MOUNTING BOLT	N/A	Included in <a href="#">18-8515</a> mounting kit.
3	<a href="#">18-0309-1</a> ELBOW GASKET	96562	Use with Exhaust Elbow: <a href="#">18-1927</a> , or <a href="#">18-1916</a> . Included in <a href="#">18-8515</a> mounting kit.
4	— MOUNTING KIT	N/A	Use with Manifold: <a href="#">18-1926</a> w/ alternator bracket
5	<a href="#">18-1928</a> ELBOW W/ 4" OUTLET	97924	Use with Manifold: <a href="#">18-1925</a> , <a href="#">18-1926</a> ; Elbow Gasket: <a href="#">18-0309-1</a> ; Mounting Kit: <a href="#">18-8515</a>
6	<a href="#">18-1934</a> ELBOW W/ 3" OUTLET	98068	Use with Manifold: <a href="#">18-1925</a> , <a href="#">18-1926</a> ; Elbow Gasket: <a href="#">18-0309-1</a> ; Mounting Kit: <a href="#">18-8515</a>
7	<a href="#">18-1918</a> ELBOW W/ 2 1/2" INLET	97386	Use with Manifold: <a href="#">18-1925</a> , <a href="#">18-1926</a> ; Elbow Gasket: <a href="#">18-0309-1</a> ; Mounting Kit: <a href="#">18-8515</a>
8	<a href="#">18-1919</a> RE-DIRECTION ELBOW W/ 3" OUTLET	97387	Use with Elbow: <a href="#">18-1918</a>
9	<a href="#">18-1924</a> RE-DIRECTION ELBOW W/ 4" OUTLET	97624	Use with Elbow: <a href="#">18-1918</a>
10	<a href="#">18-0602</a> EXHAUST MANIFOLD GASKET SET	N/A	For: "CH" Model Small Block (V8) Chevy 305 CID (5.0L) & 350 CID (5.7L)
11	NSS WASHER & NUT KIT	N/A	Used in mounting kits: <a href="#">18-8515</a> , <a href="#">18-8523</a> , & <a href="#">18-8519</a>
12	<a href="#">18-8515</a> MOUNTING KIT	N/A	Use with Elbows: <a href="#">18-1934</a> , <a href="#">18-1928</a> , <a href="#">18-1918</a>
13	<a href="#">18-8523</a> MOUNTING KIT	N/A	Use with Riser: <a href="#">18-1927</a>
14	<a href="#">18-8519</a> MOUNTING KIT	N/A	Use with Riser: <a href="#">18-1916</a>
15	<a href="#">18-8521</a> MOUNTING KIT	N/A	Use with Manifold: <a href="#">18-1925</a> & <a href="#">18-1926</a>
16	NSS MOUNTING STUD	N/A	Included in <a href="#">18-8519</a> mounting kit
17	NSS MOUNTING STUD	N/A	Included in <a href="#">18-8523</a> mounting kit
18	<a href="#">18-0305-1</a> ELBOW GASKET	96108	Use with Exhaust Manifolds: <a href="#">18-1925</a> & <a href="#">18-1926</a>
19	<a href="#">18-1926</a> MANIFOLD (PORT)	97753, 96121	GM Small Block (V8) 305-351 cu.in. (Models: 220 & 270) (Port); Use with Manifold Gasket: <a href="#">18-2949</a> ; Mounting Kit: <a href="#">18-8521</a> (if manifold has alternator bracket)
20	<a href="#">18-1925</a> MANIFOLD (STARBOARD)	97752, 96120	GM Small Block (V8) 305-351 cu.in. (Models: 220 & 270) (Starboard); Use with Manifold Gasket: <a href="#">18-2949</a> ; Mounting Kit: <a href="#">18-8521</a>
21	<a href="#">18-2949</a> MANIFOLD GASKET	96306	Use with Manifolds: <a href="#">18-1925</a> & <a href="#">18-1926</a>
22	NSS MOUNTING BOLT	N/A	Included in <a href="#">18-8521</a> mounting kits
23	<a href="#">18-8112</a> HOSE FITTING	97296; 97854	90 degree fitting. Thread Size: 1" NPT X 1 1/4"
24	<a href="#">18-4461</a> HOSE FITTING	N/A	3/4" - 14NPT X 1" Hose (Corrosion Resistant Brass Fitting)
25	<a href="#">18-1917</a> BLOCK OFF PLATE (STAINLESS)	97296	Use with Elbow/Riser Gaskets: <a href="#">18-0309-1</a> , <a href="#">18-0305-1</a>
26	<a href="#">18-1916</a> 8" RISER	97169	Use with Manifolds: <a href="#">18-1925</a> , <a href="#">18-1926</a> ; Elbow Gasket: <a href="#">18-0309-1</a> ;



# SIERRA MANIFOLDS ARE PAINTED, PACKAGED & LEAK TESTED

**18-1997-1  
MANIFOLD**

Port & Starboard

**Replaces:** Barr CHV-1-83

Universal Center Riser Manifold

**FITS:**

283 and 327 CID engines thru 1964; 305, 307  
and 350 CID engines 1965 and later

**Use with:**

Exhaust Manifold Gasket Set: **18-0604**

**\*For Exploded View - See Pages 638-639**



**18-1998-1  
MANIFOLD**

Port & Starboard

**Replaces:** Barr FM-1-83

Universal Center Riser Manifold

**FITS:**

302 and 351 CID engines  
Comes with **18-4363** Mounting Package

**Use with:**

Exhaust Manifold Gasket Set: **18-0603**

**\*For Exploded View - See Pages 640-641**

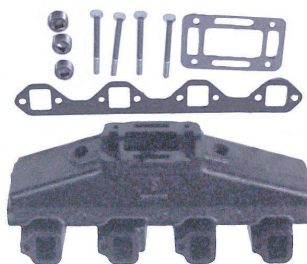

**18-1999  
ELBOW**

**Replaces:** Barr 20-0082

Comes with **18-4364** open

If blocked mounting kit is required use **18-8535**

**Use with:**

Manifold: **18-1997-1** or **18-1998-1** or **18-1898**

Riser Gasket: **18-2854-1** open



**18-1982  
MANIFOLD**

Port & Starboard

**Replaces:** Crusader 98125

**Use:**

Exhaust Manifold Gasket: **18-0418**

For: GM Big Block V-8 454-502 ci



**18-1929  
MANIFOLD**

Starboard

**Replaces:** Crusader 97992, 97114

Crusader GM Big Block V8 454cu.in.

(Models: CH350 and 454XL)

**Use with:**

Exhaust Manifold Gasket: **18-0418**

Mounting Kit: **18-8524**



**18-1933  
MANIFOLD**

Port

**Replaces:** Crusader 97993, 97115

Crusader GM Big Block V8 454cu.in.

(Models: CH350 and 454XL)

**Use with:**

Exhaust Manifold Gasket: **18-0418**

Mounting Kit: **18-8524**



**18-1925  
MANIFOLD**

Starboard

**Replaces:** Crusader 97752, 96120

Crusader GM Small Block V8 305-350cu.in.

(Models: 220 and 270)

**Use with:**

Exhaust Manifold Gasket: **18-2949**

Mounting Kit: **18-8521**



**18-1926  
MANIFOLD**

Port

**Replaces:** Crusader 97753, 96121

Crusader GM Small Block V8 305-350-cu.in.

(Models: 220 and 270)

**Use with:**

Exhaust Manifold Gasket: **18-2949**

Mounting Kit: **18-8521** (if manifold has alternator bracket)



**18-1898  
MANIFOLD**

Port & Starboard

**Replaces:** Barr CHVA-1-84

Marine Power 0991-110

Fits: 454 cu.in. GM big block V8 engines

**Use with:**

Exhaust Manifold Gasket: **18-0418**

Riser Gasket: **18-2854-1** open or **18-0476-1** blocked



**\*For Exploded View - See Pages 636-637**



**18-1991**  
**ELBOW ADAPTER**  
 Replaces: Barr 200089P  
 For: 3" I.D. Exhaust Hose  
 Use with:  
 Manifold Riser: 18-1999  
 30°



**18-1992-1**  
**ELBOW ADAPTER**  
 Replaces: Barr 200087P  
 For: 3" I.D. Exhaust Hose  
 (As used in 18-1987 Exhaust Manifold Conversion Kit)  
 80°



**18-1919**  
**RE-DIRECTION ELBOW W/ 3" OUTLET**  
 Replaces: Crusader 97387  
 Crusader GM Small Block V8 305-350-cu.in.  
 (Models: 220 and 270), GM Big Block V8 454cu.in.  
 (Models: CH350 and 454XL)  
 Use with:  
 Elbow: 18-1918



**18-1924**  
**RE-DIRECTION ELBOW W/ 4" OUTLET**  
 Replaces: Crusader 97624  
 Crusader GM Small Block V8 305-350-cu.in.  
 (Models: 220 and 270), GM Big Block V8 454cu.in.  
 (Models: CH350 and 454XL)  
 Use with:  
 Elbow: 18-1918



**18-1928**  
**ELBOW W/ 4" OUTLET**  
 Replaces: Crusader 97924  
 Crusader GM Small Block V8 305-350cu.in. (Models: 220 and 270), GM Big Block V8 454cu.in.(Models: CH350 and 454XL)  
 4" Hose  
 Use with:  
 Manifold: 18-1925, 18-1926, 18-1933, 18-1929  
 Elbow Gasket: 18-0309-1  
 Mounting Kit: 18-8515



**18-1934**  
**ELBOW W/ 3" OUTLET**  
 Replaces: Crusader 98068  
 Crusader GM Small Block V8 305-350cu.in.(Models 220 and 270), GM Big Block V8 454cu.in.(Models: CH350 and 454XL)  
 3" Hose  
 Use with:  
 Manifold: 18-1925, 18-1926, 18-1933, 18-1929  
 Elbow Gasket: 18-0309-1  
 Mounting Kit: 18-8515



**18-1918**  
**ELBOW**  
 Replaces: Crusader 97386  
 Crusader GM Small Block V8 305-350-cu.in.  
 (Models: 220 and 270), GM Big Block V8 454cu.in.  
 (Models: CH350 and 454XL)  
 2 1/2" Inlet  
 Use with:  
 Manifold: 18-1925, 18-1926, 18-1933, 18-1929  
 Elbow Gasket: 18-0309-1  
 Mounting Kit: 18-8515  
 Re-direction Elbow: 18-1919, 18-1924



**18-1916**  
**8" RISER**  
 Replaces: Crusader 97169  
 Crusader Small Block V8 305-350-cu.in.  
 (Models: 220 and 270), GM Big Block V8 454cu.in.  
 (Models: CH350 and 454XL).  
 Use with:  
 Manifold: 18-1925, 18-1926, 18-1933, 18-1929  
 Riser Gasket: 18-0305-1  
 Mounting Kit: 18-8519



**18-1927**  
**4" RISER**  
 Replaces: Crusader 97772  
 Crusader Small Block V8 305-350-cu.in.  
 (Models: 220 and 270), GM Big Block V8 454cu.in.  
 (Models: CH350 and 454XL).  
 Use with:  
 Manifold: 18-1925, 18-1926, 18-1933, 18-1929  
 Riser Gasket: 18-0305-1  
 Mounting Kit: 18-8523



**18-1938**  
**RISER**  
 Replaces: Crusader 98126, RO29015  
 Crusader GM Small Block V8 305-350cu.in.(Models: CM305, CM350XL and CM350HT), GM Big Block V8 454cu.in.(Models: 454XL and 502XL)  
 Use with:  
 Manifold: 18-1982, Crusader 98243  
 Riser Gasket: 18-0475-1  
 Mounting Kit: 18-8547



**18-1907**

**RISER (3")**

**Replaces:** Barr 20-0102  
Barr and Indmar Ford Small Block V8 302-351cu.in.  
Indmar 53-2009 and 53-2018

**Use with:**

**Manifold:** 18-1997-1, 18-1998-1  
**Riser Gasket:** 18-2854-1 open or 18-0476-1 blocked  
**Mounting Kit:** 18-4364 open or 18-8535 blocked



**18-1939**

**RISER (3 1/2")**

**Replaces:** Barr 20-0100, Marine Power 0992-593  
Barr, Indmar and Marine Power Ford Small Block  
V8 302-351cu.in., GM Small Block V8 305-350cu.in.,  
GM Big Block V8 454cu.in.

**Use with:**

**Manifold:** 18-1997-1, 18-1998-1, 18-1898  
**Riser Gasket:** 18-2854-1 open or 18-0476-1 blocked  
**Mounting Kit:** 18-4364 open or 18-8535 blocked



**18-8112**

**HOSE FITTING (90°)**

**Replaces:** Crusader 97854  
GM Small Block V8 305-350cu.in. (Models: 220,  
270, CM305, CM350XL, CM350HT), GM Big Block  
V8 454 cu.in. (Models: 454XL, 502XL, CH350, 454XL)  
Thread size: 1" NPT x 1 1/4" hose barb

**Use with:**

**Manifold:** 18-1997-1, 18-1998-1, 18-1982, Crusader 98243,  
18-1929, 18-1933, 18-1925, 18-1926, 18-1898



**18-1949**

**MANIFOLD SPACER (3")**

Barr CM 20-0097  
Barr, Indmar and Marine Power Ford Small Block  
V8 302-351cu.in., GM Small Block V8 305-350cu.in.,  
GM Big Block V8 454cu.in.

**Use with:**

**Manifolds:** 18-1998-1, 18-1997-1 and 18-1898



**18-1984**

**MANIFOLD SPACER**

**Replaces:** 98128

**For:** GM Small Block V8 305-350 cu.in., GM Big Block V8



**18-4363**

**EXHAUST ELBOW MOUNTING KIT**

**Replaces:** Barr FM-1-83-P

**Use with:**

**Manifold:** 18-1998-1

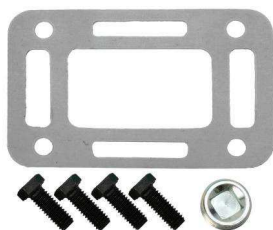

**18-4364 (Open)**

**EXHAUST ELBOW MOUNTING KIT**

**Replaces:** Barr 20-0082-P

**Use with:**

**Risers:** 18-1999, 18-1907, 18-1939



**18-8515**

**EXHAUST MANIFOLD MOUNTING KIT**

Crusader GM Small Block V8 305-350cu.in. (Models: 220, 270), GM Big Block  
V8 454cu.in. (Models: CH350, 454XL)

**Used with:**

**Elbows:** 18-1934, 18-1928, 18-1918



**18-8519**

**EXHAUST MOUNTING KIT**

Crusader GM Small Block V8 305 350cu.  
in. (Models: 220, 270), GM Big Block V8  
454cu.in.

(Models: CH350, 454XL)

**Used with:**

**Riser:** 18-1916



**18-8521**

**EXHAUST MANIFOLD MOUNTING KIT**

Crusader GM Small Block V8 305-350cu.in. (Models: 220, 270)

**Used with:**

**Manifold:** 18-1925 & 18-1926



**18-8523**  
**EXHAUST ELBOW MOUNTING KIT**  
 Crusader GM Small Block V8 305-350cu.in. (Models: 220, 270), GM Big Block V8 454cu.in.(Models: CH350, 454XL)  
**Used with:**  
 Riser: **18-1927**



**18-8524**  
**EXHAUST MANIFOLD MOUNTING KIT**  
 Crusader GM Big Block V8 454cu.in.  
 (Models: CH350 and 454XL)  
**Used with:**  
 Manifolds: **18-1929** and **18-1933**



**18-8535**  
**(CLOSED)**  
**EXHAUST ELBOW MOUNTING KIT**  
 Barr, Indmar and Marine Power Ford Small Block V8 302-351cu.in., GM Small Block V8 305-350cu.in., GM Big Block V8 454cu.in.  
**Used with:**  
 Risers: **18-1939, 18-1999, and 18-1907** Blocked



**18-8536**  
**EXHAUST ELBOW MOUNTING KIT**  
 Barr, Indmar and Marine Power GM Small Block V8 305-350cu.in.  
**Used with:**  
 Manifold: **18-1997-1**



**18-8538**  
**EXHAUST MANIFOLD MOUNTING KIT**  
 Barr and Indmar Ford Small Block V8 302-351cu.in.  
**Used with:**  
 Manifold: **18-1998-1**



**18-8547**  
**EXHAUST ELBOW MOUNTING KIT**  
 For: GM SB V8 305-350cu.in.  
 GM BB V8 454 cu. in.  
**Used with**  
 Riser: **18-1938**



**PIPE PLUGS**

Part #	Thread Size	Part #	Thread Size
18-4256	1/4"	18-4263	1/8" - 27 NPT
18-4257	1/4"	18-4264	3/8" -18 NPT
18-4258	3/4"		

**56507** Pipe Sealant with Teflon® is recommended for use on plug threads.



**18-4461**  
**HOSE BARB**  
 3/4" - 14 NPT x 1" Hose  
 Corrosion Resistant Brass Fitting



① **18-4218D**



**18-4218**  
**DRAIN TAP**  
**Used with:**  
 Most O.E.M. Manifolds  
**18-3223-9** Bulk Pack of 12  
 1/4" Brass

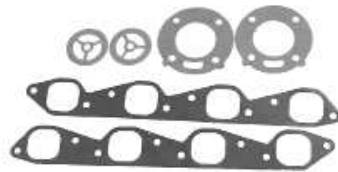



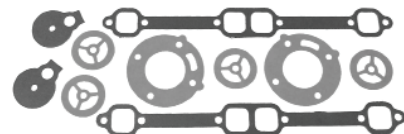







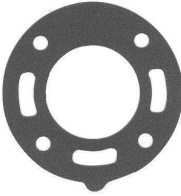

**18-0601**  
**EXHAUST MANIFOLD GASKET SET**  
 For: "CH" Model Big Block V-8 Chevy 454 CID (7.4L)  
**Use with:**  
 Manifolds: **18-1929, 18-1933**

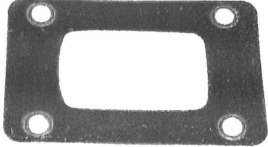

**18-0602**  
**EXHAUST MANIFOLD GASKET SET**  
 For: "CH" Model Small Block V-8 Chevy 305 CID (5.0L) & 350 CID (5.7L)

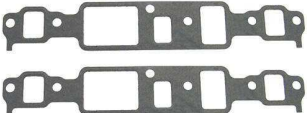
① Items ending in "D" are Display Packaged - Regular number is Non-Display

 <p><b>18-0603</b>  <b>EXHAUST MANIFOLD GASKET SET</b>          For: Ford 302/351 CID Engines          Use with:          Manifold: <b>18-1998-1</b></p>	 <p><b>18-0604</b>  <b>EXHAUST MANIFOLD GASKET SET</b>          For: GM 305/350 CID Engines          Use with:          Manifold: <b>18-1997-1</b></p>	
 <p><b>18-0183-1</b>  <b>EXHAUST MANIFOLD GASKET</b>          Used with:          Manifold: <b>18-1998-1</b></p>	 <p><b>18-0305-1</b>  <b>EXHAUST ELBOW GASKET</b>          Replaces: 96108          Use with:          Exhaust Manifold: <b>18-1929</b></p>	 <p><b>18-0309-1</b>  <b>EXHAUST ELBOW GASKET</b>          Replaces: 96562          Use with:          Exhaust Elbow: <b>18-1928</b>          V-6/V-8</p>
 <p><b>18-0418</b>  <b>EXHAUST MANIFOLD GASKET</b>          Replaces: 96653          Used with:          Manifold: <b>18-1957-2, 18-1982, 18-1929, 18-1933, 18-1898</b></p>	 <p><b>18-0475-1</b>  <b>EXHAUST ELBOW GASKET</b>          Used with:          Riser: <b>18-1938</b>          Manifold: Crusader 98243</p>	 <p><b>18-0476-1</b>  <b>BLOCK OFF GASKET</b>          Barr, Indmar &amp; MarinePower          Ford Small Block V8 302-351cu.in.          Used with:          Risers: <b>18-1939, 18-1999</b> and <b>18-1907</b>          Blocked</p>
 <p><b>18-1917</b>  <b>MANIFOLD BLOCK OFF PLATE (STAINLESS)</b>          Replaces: 97296          Crusader Small Block V8 305-350 cu.in. (Models: 220 and 270), GM Big Block V8 454cu.in. (Models: CH350 and 454XL)          Use with:          Elbow/Riser Gasket: <b>18-0309-1, 18-0305-1</b></p>	<p>PKG. OF 2</p>  <p><b>18-2854-1 (Open)</b>  <b>18-2854-9</b>①  <b>EXHAUST RISER GASKET</b>          Replaces: Barr 01-0107          Used with:          Riser: <b>18-1999, 18-1907, 18-1939</b></p>	<p>PKG. OF 2</p>  <p><b>18-2909</b>  <b>18-2909-9</b>①  <b>EXHAUST MANIFOLD GASKET</b>          Replaces: 97498          For: GM V-6          Used with:          Manifold: <b>18-1952-1, 18-1932</b></p>
<p>PKG. OF 2</p>  <p><b>18-2949</b>  <b>18-2949-9</b>①  <b>EXHAUST MANIFOLD GASKET</b>          Replaces: 96306          Barr CHV-47-000          Use with:  <b>18-1997-1</b></p>	 <p><b>18-4408</b>  <b>INTAKE MANIFOLD GASKET SET</b>          Replaces: 33393          For: 222 CID</p>	 <p><b>18-0306-1</b>  <b>ELBOW AND CUP GASKET</b>          Replaces: 96216          V-6/V-8</p>

① Priced per Package



### OIL FILTERS

Part #	Replaces:	
<b>18-7824-2 (Short)</b>	201104	GM Engines + SS330 Remote Mount
<b>18-7875 (Long)</b>	9002514	Ford Engines
<b>18-7876-1 (Long)</b>	201104	GM Engines + SS330 Remote Mount
<b>18-7878-1 (Short)</b>	—	220, 300, 320, 325 Remote Mount

**SEE PAGES 182-184 & 1147-1170 FOR ADDITIONAL INFORMATION**



**18-0311**  
262 CID  
**VALVE COVER GASKET**  
Replaces: 97686



PKG. OF 2  
**18-0875**  
**18-0875-9**①  
**THERMOSTAT GASKET**



PKG. OF 2  
**18-0976**  
**18-0976-9**①  
**TIMING CHAIN COVER GASKET**  
Replaces: 20129



**18-2845**  
**VALVE COVER GASKET**  
Replaces: 91351  
V-8

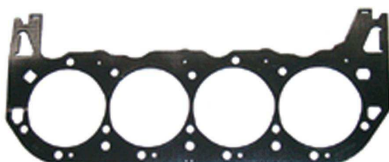

**18-3874**  
**HEAD GASKET**  
Replaces: 31137  
For: (8.2L) 502 CID/7.4L



**18-3876**  
**HEAD GASKET**  
Replaces: 7057500  
For: GM 305 (5.0L)/350 (5.7L) CID Eng.



**18-3877**  
**HEAD GASKET**  
Replaces: 30266  
For: GM 454 (7.4L) CID Eng.

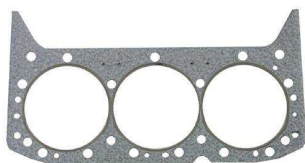

**18-3879**  
**HEAD GASKET**  
Replaces: 33408



**18-3887**  
**HEAD GASKET**  
Replaces: 31136  
For: (7.4L) 454 CID GEN V

① Priced per Package