

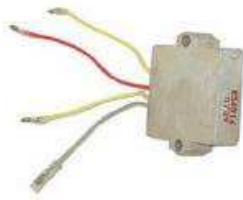

**18-5742  
VOLTAGE REGULATOR**

**Replaces:** 8152792, 815279T3, 815279T2, 830179A2, 817411, F746470, F718470  
Force engines with 16 amp - 20 amp charging system model years 1991-92

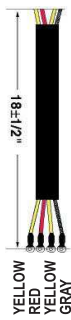

**18-5744  
VOLTAGE REGULATOR**

**Replaces:** 8152794, 883071A1, 856747T1, 854514A1, 830179A1, 8174111, 815279T5, 815279T4  
Force engines with 16 amp - 20 amp charging system model years 1993-present

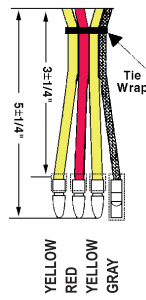

**18-6762  
TILT/TRIM MOTOR**

**Replaces:** 449541-3, 455541



**18-6775  
TILT/TRIM MOTOR**

**Replaces:** 824051, 830250A6  
**For:** 90 HP (1995-97) and 120 HP (1995-97)  
Contains: All parts necessary, a new 3-wire motor/reservoir, drive shaft coupler, oil seal, o-ring and hardware.

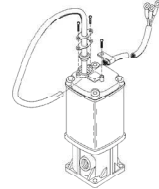

If you have this 3-wire single ram system, use **18-6775**



**18-6286  
TILT/TRIM MOTOR**

Heavy Duty Late Model Mercury/Force 25-50HP Outboards w/2-wire connection and flat blade shaft.  
4 bolt mount.  
**Replaces:** 827675A1



**18-6279  
TILT/TRIM MOTOR**

**Replaces:** 820545, F694541-1  
Late model Force outboards w/2 wire connection

**18-6777  
TILT/TRIM MOTOR**

**Replaces:** 818903A1, 819762A4-A7, 819479A1, 819480A1, 81977A8-A9, 822870A1, 830250A3-T3, 832021A1-T4-A2-T2, 855654A1-T2, 19217A1-A5  
Contains: All parts necessary, a new 2-wire motor/reservoir, drive shaft coupler, oil seal, O-ring and hardware.

For:

HP	Years	HP	Years
40	1992-94	90	1991-94
50	1991-94	120	1990-94
70	1991-95	150	1989-94
75	1996-99		

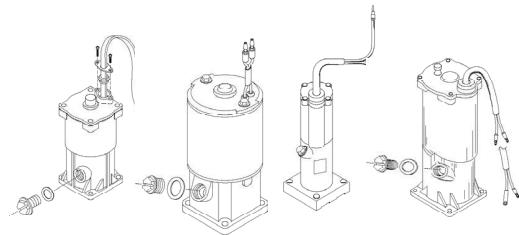

If you have any of the 2-wire single ram systems, use **18-6777**



**18-6439  
STARTER**

**Replaces:** 50-803903T, 50-F575955  
**Fits:** 50HP (1984-92)



**18-6441  
STARTER**

**Replaces:** 50-803900T, 50-F514955  
**Fits:** 25 HP (1983-84, 1989), 30 hp (1979), 35 HP (1976-78, 1986-91)



**18-5613  
OUTBOARD STARTER**

**Replaces:** Mercury/Force FK616955, F616955, F490955, F480955, FS438955, F438955-1, F85955-1, FA85955, FS438955, FS480955, FS489955, FS490955



**18-5618  
OUTBOARD STARTER**

**Replaces:** Mercury/Force 50-819968-2, 50-8199684, 50-8199683, 50-8199681, 50-819968, 50-898265003



**18-5622  
OUTBOARD STARTER**

**Replaces:** Mercury/Force 50-820193, 50-820193T1



**18-5673  
DRIVE ASSEMBLY**

**Replaces:** Mercury/Force F15100, F15110, 819222



**18-5697  
DRIVE BRUSH KIT**







**Replaces:** 75384, F15164

APPLICATION BEGINS ON NEXT PAGE

CHRYSLER/FORCE							
Years	Starter	OEM #	Drive Assembly	O.E. #	Tooth Count	Drive Brush Kit	O.E. #
1983-84	18-6441	50-F514955/514955	18-5655	F15150	10	18-5697	F15157
1989	18-6441	50-F514955/514955	18-5655	F15150	10	18-5697	F15157
1979	18-6441	50-F514955/514955	18-5655	F15150	10	18-5697	F15157
1976-78	18-6441	50-F514955/514955	18-5655	F15150	10	18-5697	F15157
1986-91	18-6441	50-F514955/514955	18-5655	F15150	10	18-5697	F15157
1966-89	①	201955/FK575955	—	F15150	9	18-5697	F15164
1966-92	18-6439	50-F575955	18-5655	F15150	10	18-5697	F15164
1966-92	①	50-F514955/514955	—	—	10	18-5697	F15164
1992-99	18-5622	50-820193/50-820193T1	18-5677	811902	13	18-5697	F15164
1992-94	①	50-819271/50-820193A1	18-5677	811902	13	18-5697	F15164
1966-89	18-5613	50-819085/F616955-1/F616955	—	819222	9	18-5697	F15164
1966-89	18-5613*	480955/FK616955	—	F15100, F15110	9	18-5697	F15164
1991-95	18-5613	50-819085/F616955-1/F616955	—	819222	9	—	F15190
1996-98	18-5613	50-819085/F616955-1/F616955	—	819222	9	—	F15190
1989	18-5613	50-819085/F616955-1/F616955	—	819222	9	18-5697	F15164
1992-97	18-5618	50-819968-2	—	820583	9	—	F15190
1991-98	18-5613	50-819085/F616955-1/F616955	—	819222	9	—	F15190
1990-91	18-5613	50-819085/F616955-1/F616955	—	819222	9	18-5697	F15164
1990-91	18-5613	50-819085/F616955-1/F616955	—	819222	9	18-5697	F15164
1990-94	18-5613	50-819085/F616955-1/F616955	—	819222	9	18-5697	F15164
1989A-1992C	18-5613	50-819085/F616955-1/F616955	—	819222	9	—	F15190
1989-1994	18-5613	50-819085/F616955-1/F616955	—	819222	9	—	F15190

① No replacement starter available, drive parts only

\* Only fits 140 HP (1983-1984)

 <p><b>18-7033 CARB KIT</b> Replaces: FK10003, FK10026, FK10053, FK10102-1</p>	 <p><b>18-7037 CARB KIT</b> Replaces: FK10004, FK10005, FK10007, FK10008, FK10027, FK10057, FK10108, FRK739</p>	 <p><b>18-7041 NEEDLE &amp; SEAT</b> Replaces: FO16311, FO10790</p>	
 <p><b>18-7057 NEEDLE &amp; SEAT</b> Replaces: F010790 .078 Bore</p>	 <p><b>18-7805 FUEL PUMP KIT</b> Replaces: F24747-1</p>	 <p><b>18-7806-1 FUEL PUMP KIT</b></p>	 <p><b>18-7817 DIAPHRAGM KIT</b> Replaces: 21-42990A7, A8, A9, A10, 21-857005A1</p>

**CHRYSLER**

HP	Model	Carb Kit	Needle & Seat	Fuel Pump Kit
3.6	32/33HA,HB,HC	18-7037	18-7057	N/A
4.5	42HA	18-7037	18-7057	18-7805
5	52/53HA	—	—	18-7805
6	60HA	18-7037	18-7057	18-7805
6	60H0D,H8B,H9C	—	—	18-7805
6	61H0C,H8B,H9B	—	—	18-7805
6	62H8J,H9K,H9L	—	—	18-7805
6	67H9B,H9C	—	—	18-7805
6	62/63H9M	18-7037	18-7057	18-7805
6	62/63HA ①	18-7037	18-7057	18-7805

① S/N 3001 & up

APPLICATION CONTINUED ON NEXT PAGE

**CHRYSLER (Cont.)**

HP	Model	Carb Kit	Needle & Seat	Fuel Pump Kit
6	62/63HA ②	—	—	18-7805
6	62/63H9M,HC,HD,HE,HF,HG,HH	18-7037	18-7057	18-7805
6	64HA,HB,HC	18-7037	18-7057	18-7805
6	64H0F,H1G,H2H,H9E,65H0A	—	—	18-7805
6	64H8D	18-7037	18-7057	18-7805
7	72/73HA	—	—	18-7805
7.5	70H9A	—	—	18-7805
7.5	71H1B,H2C,H3D,H9A	—	—	18-7805
7.5	72H1D,H2E,H3F,H0C,H9B	—	—	18-7805
7.5	75H9A,77H0B,H1C,H9B	—	—	18-7805
8	82/83HA,HC,HD,HE,HF,HG,HH,H9K	18-7037	18-7057	18-7805
8	82/87H8J	—	—	18-7805
9.9	91H0B,H9A	18-7037	18-7057	18-7805
9.9	91H3C,95H3J	—	—	18-7805
9.9	92H1H,98H1B	18-7037	18-7057	18-7805
9.9	92H1J/H2J,H3K	—	—	18-7805
9.9	92/93H0G,H9F,HD,HE	18-7037	18-7057	18-7805
9.9	92/93HA	—	—	18-7805
9.9	92/93HB ④	18-7037	18-7057	18-7805
9.9	92/93HB ⑤	—	—	18-7805
9.9	94H1F,94/95HA,95H2H	—	—	18-7805
9.9	94/95HB,HD,HE, 95H0F,H1G	18-7037	18-7057	18-7805
9.9	98H2C 98/99H9A	—	—	18-7805
10	100HA,101H8B	18-7037	18-7057	18-7805
10	102/103HA,HB,HC,HD,H8B	18-7037	18-7057	18-7805
10	104/105HA,HB,HC	18-7037	18-7057	18-7805
10	108/109HA,H8B	18-7037	18-7057	18-7805
12	121H9A,125H9E	18-7037	18-7057	18-7805
12.9	122/123HA,HC,HD,H9E	18-7037	18-7057	18-7805
12.9	124/125HA,HC,HD	18-7037	18-7057	18-7805
12.9	128/129 H9A	18-7037	18-7057	18-7805
15	152H1G	18-7037	18-7057	18-7805
15	152H1H,H2H,H3J	—	—	18-7805
15	158H3D	—	—	18-7805
15	152/153HA,HC,HB,H0F,H8D,H9E	18-7037	18-7057	18-7805
15	154HB,154/155HA	18-7037	18-7057	18-7805
15	158/159,HA,H8B,H9C	18-7037	18-7057	18-7805
20	202/203HA,HB,HD,HE,HF,HG	—	—	18-7805
20	202/3H0L,H1M,H9K,202H2N	18-7037	18-7057	—
20	204/205HA,HB,HD,HE,HF,HG	—	—	18-7805
20	206/207H9B	18-7037	18-7057	—
25	252H3G,257H3D ⑥	18-7037	18-7057	—
25	252/253HA,HB,H8C,H8D,252H1F,H2F	18-7037	18-7057	—
25	254/255HA,HB 256/257HA,HB	18-7037	18-7057	—
30	302/303HA,HB	18-7037	18-7057	—
30	302/303H9C	—	18-7057	—
30	304/305HA,HB	18-7037	18-7057	—
30	306/307H0C,H9B	—	18-7057	—
30	306/307HA,307H1D,H2E	18-7037	18-7057	—
35	350 THRU 355HA,HC,HD	18-7037	18-7057	18-7806-1
35	350/351,HE,HF,HG,HH,HK,H8L	18-7037	18-7057	—
35	352/353H8K,H9L,353H0M,H1N	18-7037	18-7057	—

① S/N 3001 & up                      ② S/N 3000 & under  
 ③ 554HF S/N 11072 & up 555HF 14439 & up, 557HF 14581 & up 558HF 11108 & up, 559HF 14309 & up  
 ④ Tillotson carb CO-3A              ⑤ Tillotson carb MD-144A              ⑥ Tillotson carb WB-19D

APPLICATION CONTINUED ON NEXT PAGE

CHRYSLER (Cont.)				
HP	Model	Carb Kit	Needle & Seat	Fuel Pump Kit
35	352/353HE, HF, HG, HH, HJ, H2P	18-7037	18-7057	—
35	354/355HE, HF, HG, HH	18-7037	18-7057	—
35	356/357HC, HD, HC, HE, HF, HK, H8M	18-7037	18-7057	—
35	357H3N, R3P, 360/361HA, HB	18-7037	18-7057	—
35	356/357HA, HB	18-7037	18-7057	18-7806-1
45	450/451HK	18-7037	18-7057	—
45	450 THRU 457HA, HC, HD	18-7037	18-7057	18-7806-1
45	450 THRU 457HE, HF, HG, HH	18-7037	18-7057	—
45	452/453HJ, H8K	18-7037	18-7057	—
45	456/457H0L, HJ, H1M, H9K, 457H2N	18-7037	18-7057	—
45	458/459HA, HB	18-7037	18-7057	18-7806-1
45	458/459HD, HC, HE, HF, HG	18-7037	18-7057	—
45	459H0J, H9H	18-7037	18-7057	—
45	468/469HA	18-7037	18-7057	—
50	503H3A, 507H1A, H2B, H2C, H3D, R3E	18-7037	18-7057	—
55	551HA, 554 THRU 559HA, HD, HF ③	18-7037	18-7057	18-7806-1
55	554 THRU 559HE, HG	18-7037	18-7057	—
55	558/559HH, HJ, HK, H9L	18-7033	18-7057	—
55	559H0M, H0N, H1N, H2P, H3R, V3S	18-7033	18-7057	—
60	608/609HA	18-7033	18-7057	—
65	659HA, HB	—	18-7057	—
70	706/707HA, HC, HD, HE	18-7033	18-7057	18-7806-1
70	706/707HF, 709HOAN, H9A	18-7037	18-7041	—
70	T700H9A	18-7037	18-7057	—
75	754H0B, 456H0F, H2H, 757HD, H9E	18-7033	18-7057	—
75	756/757HA, HB, HC, 756H1G	18-7037	18-7041	—
75	758H0B, H1C, P/S759H9A	18-7037	18-7041	—
75	758H2D, T750H9A	18-7037	18-7057	—
85	850H0A, H1C, 851H9A, P/S855H9A	18-7033	18-7057	—
85	856H0H, H1J, H2K	18-7033	18-7057	—
85	856/7HA, HC, HD	18-7033	18-7057	18-7806-1
85	856/7HE	18-7037	18-7041	—
85	857HF, H9G	18-7033	18-7057	—
85	858H0C, H1D, H2E	18-7033	18-7057	—
85	859HA, H8A, H9B, T850H9A	18-7033	18-7057	—
90	906/907HA, HB, HC	18-7033	18-7057	—
100	T1000H9A, 1002H0AN, 1004H0B, H9A	—	18-7057	—
100	1006H0B, H1C, 1007H9A, 1008H0A, H1B	—	18-7057	—
105	1055HA	18-7037	18-7057	—
105	1055HB	—	18-7057	—
105	1056/1057HA, HB, HC, HD	18-7037	18-7057	18-7806-1
105	1056/1057HE, HF	18-7037	18-7057	—
105	1057HH, 1058H2G	—	18-7057	—
105	1058 HA, HB, HC	18-7037	18-7057	18-7806-1
105	1058/9HD, HE	18-7037	18-7057	—
105	1058/1059HF, 1059HG	—	18-7057	—
115	1159HA	—	18-7057	—
120	1206/1207HA, HB, HC, HD	18-7037	18-7057	18-7806-1
120	1206/1207HE, HF	18-7037	18-7057	—
120	1208HA, HB, HC	18-7037	18-7057	18-7806-1
120	1208/1209HD, HE	18-7037	18-7057	—
120	1208/1209HF, 1209HG	—	18-7057	—
130	1306/1307HA	18-7037	—	18-7806-1
135	1358HA, HB, HC	18-7037	18-7057	18-7806-1
150	1508HA	18-7037	—	18-7806-1

③ 554HF S/N 11072 & up 555HF 14439 & up, 557HF 14581 & up 558HF 11108 & up, 559HF 14309 & up

## FORCE

HP	MODEL	YEAR	BEGINNING SERIAL #	ENDING SERIAL #	FUEL PUMP KIT
5	5	1988-1996	N/A	N/A	18-7805
7.5	7.5	1985	N/A	N/A	18-7805
9.9 / 15	9.9 / 15	1984-1998	N/A	N/A	18-7805
25	25	1989	N/A	N/A	18-7806-1
35	35	1986-1987	N/A	N/A	18-7806-1
35A	35A	1988-1991	N/A	N/A	18-7806-1
35B	35B	1988-1991	N/A	N/A	18-7806-1
35C	35C	1989-1991	N/A	N/A	18-7806-1
40 / 50	40 / 50	1992	E000001	E065371	18-7806-1
40 / 50	40 / 50	1992-1994	E065372	E093669	18-7817
40 / 50	40 / 50	1995	E093700	E138599	18-7817
40 / 50	40 / 50	1997-1999	E138600	& UP	18-7817
50	50	1984-1992	N/A	N/A	18-7806-1
60	60	1985	N/A	N/A	18-7806-1
70	70	1991B / 1992C	E000001	E039023	18-7806-1 ①
70	70	1992-1995	E039024	E138599	18-7817 ②
75	75	1996-1999	E138600	& UP	18-7817
85	85	1983-1988 / 1989A, 1989B	N/A	N/A	18-7806-1
85	85	1989C-H / L-DRIVE	N/A	N/A	18-7806-1
90	90	1991A / 1991B / 1991C	N/A	N/A	18-7806-1
90	90	1991D-1992C	E000001	E039023	18-7806-1 ①
90	90	1992-1994	E039024	E093699	18-7817 ②
90	90	1995-1999	E093700	& UP	18-7817
90	90 L-Drive	1991	N/A	N/A	18-7806-1
90	90	1990	N/A	N/A	18-7806-1
90	90 L-DRIVE	1990	N/A	N/A	18-7806-1
90	SPORT JET 90	1993-1994	E023150	E066619	18-7806-1
90	SPORT JET 90	1995-1996	E138325	E138599	18-7806-1
90	SPORT JET 90XR	1996-1997	E141089	& UP	18-7806-1
120	120	1990A-1991C	N/A	N/A	18-7806-1
120	120	1991D-1992C	E000001	E093699	18-7817 ①
120	120	1993-1994	E000001	E093699	18-7817
120	120	1995	E093700	E138599	18-7817
120	120	1996-1999	E0138600	& UP	18-7817
120	120 L-DRIVE	1990-1992	N/A	N/A	18-7806-1
120	120 SPORT JET	1995-1997	E095088	E138599	18-7806-1
125	125	1984-1989	N/A	N/A	18-7806-1
125	125 L-DRIVE	1989	N/A	N/A	18-7806-1
150	150	1989-1992	UP TO	E065371	18-7806-1
150	150	1993-1994	E000001	E093699	18-7817

① Serial # E000001-E065371 use 18-7806-1

## FUEL WATER SEPARATORS



Sierra offers a complete line of 10 and 21 micron fuel water separating filters including drainable bowl filters to protect your carbureted and fuel injected engine.

**Refer to pages 136-140 for a complete listing of OEM and universal applications.**

*Sierra fuel water separators remove over 99.8% of emulsified water from your gasoline. Sierra's 10 micron filters are over 90% efficient at removing particles as small as 10 micron. All filters flow @ 90 GPH to feed even the hungriest motor. Sierra 10 micron filters are recommended to prevent damage to sensitive inboard and outboard fuel injection systems.*

### 8' LENGTH COMPLETE FUEL LINE ASSEMBLIES

3/8"  
FUEL LINE ASSEMBLY

18-8011EP-2 SILVERADO 4000 Premium

OE# FS409752



**18-8071**  
TANK  
CONNECTOR  
(SOLD SEPARATELY)



**18-8005EP-1**  
PRIMER  
BULB



**18-8062**  
FUEL  
CONNECTOR



FUEL LINE ASSEMBLY COMPONENTS

### CHRYSLER FUEL APPLICATION

Engine	Year
6 HP	1976-82
7.5 HP	1979-85
8 HP	1976-79
9.9 HP	1979-95
10 HP	1976-78
12 HP	1979
15 HP	1976-95
20 HP	1978-82
25 HP	1975-78, 1981-84, 1989
30 HP	1979-82

Engine	Year
35 HP	1974-89
40 HP	1992-94
45 HP	1974-84
50 HP	1981-94
55 HP	1974-83
60 HP	1984-85
65 HP	1978
70 HP	1979-80, 1991-95
75 HP	1975-84
85 HP	1977-88

Engine	Year
90 HP	1975-77, 1983-84, 1991-94
100 HP	1979-84
105 HP	1976-78, 1982
115 HP	1977-84
120 HP	1976-77, 1990-94
125 HP	1981-88
135 HP	1976-77
140 HP	1978-84
150 HP	1989-94



**18-8002EP-1**  
18-8002EP-1-10<sup>①</sup>  
PRIMER BULB  
1/4"

**18-8004EP-1**  
18-8004EP-1-10<sup>①</sup>  
PRIMER BULB  
5/16"  
Large capacity bulb

**18-8005EP-1**  
18-8005EP-1-10<sup>①</sup>  
PRIMER BULB  
3/8"  
Large capacity bulb

<sup>①</sup> Discount shop pack of 10 - Priced per package



**18-8062**  
FUEL CONNECTOR  
3/8" barb  
Replaces: 197787-3  
Mates with **18-8071**



**18-8071**  
TANK CONNECTOR  
1/4" NPT .432 O.D.  
Mates with **18-8062**  
(Male)



**18-3550**  
THERMOSTAT  
Replaces: F85068-2, F84068-2,  
F85068-1, F85068  
140°



**18-3556**  
THERMOSTAT  
Replaces: F97068-2  
3/4" - 130°



**18-3557**  
THERMOSTAT  
Replaces: F335068  
1" - 143°



**18-3559**  
THERMOSTAT  
Replaces: F528068  
1" - 110°



**18-3030**  
IMPELLER  
Replaces: 47-803630T,  
F523065, F523065-1  
For: Force outboard, 85 HP  
(1975-89, except 1989 D, F, G, H), 125  
HP A,B,&C (1981-88)



**18-3017**  
18-3017-10<sup>②</sup>  
IMPELLER  
Replaces: 47-89984T4,  
47-F694065, 47-803631T



**18-3056**  
18-3056-10<sup>②</sup>  
IMPELLER  
Replaces: 47-430262



**18-3057**  
IMPELLER  
Replaces: 47-85089-3

### APPLICATION ON NEXT PAGE

<sup>①</sup> Items ending in "D" are Display Packaged - Regular number is Non-Display  
<sup>②</sup> Discount shop pack of 10 - Priced per package

 <p><b>18-3062</b> <b>IMPELLER</b> Replaces: 47-42038-2, 002</p>	 <p><b>18-3084</b> <b>IMPELLER</b> Replaces: 47-F40065-2</p>	 <p><b>18-3085</b> <b>IMPELLER</b> Replaces: 47-F84065</p>	 <p><b>18-8900</b> <b>IMPELLER</b> Replaces: 47-19453</p>
 <p><b>18-8901</b> <b>IMPELLER</b> Replaces: 47-F462065</p>	 <p><b>18-8903</b> <b>IMPELLER</b> Replaces: 47-F436065-2</p>	 <p><b>18-45003</b> <b>IMPELLER</b> Replaces: 47-F433065 Fits: Force 35/45/55 hp (1974-80)</p>	 <p><b>18-3240</b> <b>WATER PUMP KIT</b> For: 9.9HP (1979-97) 10HP (1974-78) 12HP (1979) 15HP (1974-97) 20HP (1973-78) 25HP (1973-78)</p>

① **18-3251D** Display Package



**18-3251**  
**WATER PUMP KIT**  
For: 85HP (1989 D, F, G, H) 90HP (all except 1995-97 & Sport Jet) 120HP (all except 1995-97 & Sport Jet) 125HP (1988-89) 150HP (1989-up)

— CONTAINS —

Part #	Desc.	O.E. #	Qty.
18-0416	Gasket, Wear Plate	27-F694830	1
18-3017	Impeller	47-89984T4	1

① **18-3214D** Display Package



**18-3214**  
**IMPELLER REPAIR KIT**  
Replaces: 46-43024A7

— CONTAINS —

Part #	Desc.	O.E. #	Qty.
18-2564	Water Pump Base to Face Plate Gasket	27-43033-1	1
18-2565	Water Pump Base to Gear Hsg. Gasket	27-43047-1	1
18-2566	Face Plate to Water Pump Cover Gasket	27-817277	1
18-2944	Seal Ring	26-45577	1
18-3056	Impeller	47-43026-1	1
18-3122	Impeller Plate	817276	1
18-7420	O-Ring	25-21836	1

① **18-3215D** Display Package



**18-3215**  
**IMPELLER REPAIR KIT**

— CONTAINS —

Part #	Desc.	O.E. #	Qty.
18-2560	Impeller Washer Gasket	12-86645	2
18-2561	Gear Hsg. to Face Plate Gasket	27-85087	1
18-2562	Gear Hsg. to Face Plate Gasket	27-99326-1	1
18-3057	Impeller	47-85089-3	1
18-7419	O-Ring	25-69202	1

① Items ending in "D" are Display Packaged - Regular number is Non-Display  
 ② Discount shop pack of 10 - Priced per package

**CHRYSLER/FORCE**

HP	Year	Serial No.	Impeller	Impeller Kit	Thermostat
9.9	1979-97	ALL	18-8903	18-3240	—
9.9/15	1998	E288600-E344999 ①	18-3062	—	—
10	1974-78	ALL	18-8903	18-3240	—
12	1979	ALL	18-8903	18-3240	—
15	1974-97	ALL	18-8903	18-3240	—
20	1973-78	ALL	18-8903	18-3240	—
20	1979-82	ALL	18-8901	18-3240	—
25	1973-78	ALL	18-8903	18-3240	—
25	1996-98	E127700-E344999	18-3057	18-3215	18-3556
30	1980-82	ALL	18-8901	—	—
35	1976-78, 83-84 & 86-88	ALL	18-8901	—	18-3556
35	1979-82	ALL	18-3084	—	18-3556
40/50	1992-94	E065372-E093669	—	—	18-3556
40/50	1995-99	E093700-E369299	18-3057	—	18-3556

① Except model "C" for 1988      ② 1989 "D" & "E" models      ③ Mercury Lower Unit

**APPLICATION CONTINUED ON NEXT PAGE**

CHRYSLER/FORCE (Cont.)					
HP	Year	Serial No.	Impeller	Impeller Kit	Thermostat
50	1984-91,1992A	N/A	—	—	18-3556
70	1979-80	ALL	18-3085		18-3559
70	1991-95	E138600-E345999	18-8900	—	—
75	1979	ALL	18-3085		18-3559
75	1980	ALL	18-3030		18-3559
75	1996-98	E138600-E345999	18-8900	—	—
75	1999	E345000-UP	18-3057	—	—
85	1977-88	ALL	18-3030		18-3559
85	1989	A,B	18-3030		18-3559
85	1989	C,E	18-3030		—
85	1989	D, F, G, H	18-3017		—
85	L-DRIVES 1989	A,B,C	18-3017	—	—
90	1991A,B,C,D-1992C	E000001-E039023	18-3017	18-3251	—
90	1992-94	E039024-E093699	18-3017	18-3251	—
90	1995-97	E093700-UP	18-3056	18-3214	—
90 L-DRIVE	1991	N/A	18-3017	18-3251	—
90 & L-DRIVE	1990	N/A	18-3017	18-3251	—
SPORT JET 90	1993-94	E023150-E066619	—	—	—
SPORT JET 90	1995-96	E138325-E138599	—	—	—
SPORT JET 95XR	1996-97	E141089-UP	—	—	—
100	1979-80	ALL	18-3030		18-3559
105	1977-78	ALL	18-3030		18-3559
115	1977-80	ALL	18-3030		18-3559
120/135	1977	ALL	18-3030		18-3559
120	1990A-91C	N/A	18-3017	18-3251	—
120	1991D-92C& 1993, 1994	E000001-E093699	18-3017	18-3251	—
120	1995-97	E093700-UP	18-3056	18-3214	—
120 L-DRIVE	1990-92	N/A	18-3017	18-3251	—
120 SPORT JET	1995-97	E095088-E138599	—	—	—
125	1981-89	ALL	18-3030	—	18-3559 □ □
125	1988	C	18-3030	—	—
125 L-DRIVE	1989	N/A	18-3017	18-3251	18-3559
140	1978-80	ALL	18-3030		18-3559
150	1989-92	UP TO E065371	18-3017	18-3251	—
150	1993-UP	E000001-E093699	18-3017	18-3251	—

① Except model "C" for 1988      ② 1989 "D" & "E" models      ③ Mercury Lower Unit

**CHRYSLER IMPELLER APPLICATION**

HP	Model	Year	Serial #	Impeller	Impeller Kit	Thermostat
9.9	9.9	1979-1997	All	18-8903	18-3240	N/A
9.9 / 15	9.9 / 15	1998	E288600 - E344999 ①	18-3062	N/A	N/A
10	10	1974-1978	All	18-8903	18-3240	N/A
12	12	1979	All	18-8903	18-3240	N/A
15	15	1974-1997	All	18-8903	18-3240	N/A
20	20	1973-1978	All	18-8903	18-3240	N/A
20	20	1979-1982	All	18-8901	18-3240	N/A
25	25	1973-1978	All	18-8903	18-3240	N/A
25	25	1996-1998	E127700 - E344999	18-3057	18-3215	18-3556
30	30	1980-1982	All	18-8901	N/A	N/A
35	35	1976-1978	All	18-8901	N/A	18-3556
35	35	1983-1984	All	18-8901	N/A	18-3556
35	35	1986-1988	All	18-8901	N/A	18-3556

① Mercury lower unit      ② Except model "c" for 1988      ③ 1989 "D" & "E" models

**APPLICATION CONTINUED ON NEXT PAGE**



### CHRYSLER IMPELLER APPLICATION

HP	Model	Year	Serial #	Impeller	Impeller Kit	Thermostat
35	35	1979-1982	All	18-3084	N/A	18-3556
40 / 50	40 / 50	1992-1994	E065372 - E093669	N/A	N/A	18-3556
40 / 50	40 / 50	1995-1999	E093700 - E369299	18-3057	N/A	18-3556
50	50	1984-1991	N/A	N/A	N/A	18-3556
50	50	1992A	N/A	N/A	N/A	18-3556
70	70	1979-1980	All	18-3085	N/A	18-3559
70	70	1991-1995	E138600 - E345999	18-8900	N/A	N/A
75	75	1979	All	18-3085	N/A	18-3559
75	75	1980	All	18-3030	N/A	18-3559
75	75	1996-1998	E138600 - E345999	18-8900	N/A	N/A
75	75	1999	E345000 & UP	18-3057	N/A	N/A
85	85	1977-1988	All	18-3030	N/A	18-3559
85	85	1989	A, B	18-3030	N/A	18-3559
85	85	1989	C, E	18-3030	N/A	N/A
85	85	1989	D, F, G, H	18-3017	N/A	N/A
85	L-DRIVES	1985	A, B, C	18-3017	N/A	N/A
90	A, B, C, D	1991	E000001 - E039023	18-3017	18-3251	N/A
90	C	1992	E000001 - E039023	18-3017	18-3251	N/A
90	90	1983-1984	ALL	18-3030	N/A	N/A
90	90	1992-1994	E039024 - E093699	18-3017	18-3251	N/A
90	90	1995-1997	E093700 & UP	18-3056	18-3214	N/A
90	90 L-DRIVE	1991	N/A	18-3017	18-3251	N/A
90	90 / 90 L-DRIVE	1990	N/A	18-3017	18-3251	N/A
90	SPORT JET 90	1993-1994	E023150 - E066619	N/A	N/A	N/A
90	SPORT JET 90	1995-1996	E138325 - E138599	N/A	N/A	N/A
95	SPORT JET 95XR	1996-1997	E141089 & UP	N/A	N/A	N/A
100	100	1979-1981	ALL	18-3030	N/A	18-3559
100	100	1983-1984	ALL	18-3030	N/A	N/A
105	105	1977-1978	ALL	18-3030	N/A	18-3559
105	105	1982	ALL	18-3030	N/A	N/A
115	115	1977-1982	ALL	18-3030	N/A	18-3559
120 / 135	120 / 135	1977	ALL	18-3030	N/A	18-3559
120	1990A	1990	N/A	18-3017	18-3251	N/A
120	1991C	1991	N/A	18-3017	18-3251	N/A
120	1991D	1991	E000001 - E093699	18-3017	18-3251	N/A
120	1992C	1992	E000001 - E093699	18-3017	18-3251	N/A
120	1993-1994	1993-1994	E000001 - E093699	18-3017	18-3251	N/A
120	120	1995-1997	E093700 & UP	18-3056	18-3214	N/A
120	120 L-DRIVE	1990-1992	N/A	18-3017	18-3251	N/A
120	120 SPORT JET	1995-1997	E095088 - E138599	N/A	N/A	N/A
125	125	1981-1989	ALL	18-3030	N/A	18-3559 ②③
125	125	1988	C	18-3030	N/A	N/A
125	125 L-DRIVE	1989	N/A	18-3017	18-3251	18-3559
140	140	1978-1982	ALL	18-3030	N/A	18-3559
150	150	1989-1992	UP TO E065371	18-3017	18-3251	N/A
150	150	1993 & UP	E000001 - E093699	18-3017	18-3251	N/A

① Mercury lower unit    ② Except model "c" for 1988    ③ 1989 "D" & "E" models



**FORCE PISTON APPLICATION**

HP/Model	Cyl.	Bore Size	Piston	OEM Part #	Rings	OEM Part #
40-50	2	3.312 / STD.	18-4629	700-834794T3, FA691015, 700-F694015	18-39010 ①	39-817869A1, FA663260
40-50	2	3.322 / .010	18-4630	700-834794A4, 700-FSA694015	—	39-817869A2, FSA335260
40-50	2	3.342 / .030	18-4631	700-834794A5, 700-818134A1	—	39-817869A3, 39-818110A1
40-50	2	3.375 / STD.	18-4632	700-834800A4, 700-819005A8	18-3998 ①	39-8204757A2, FA528269, FA528260, 39-820457A1, 39-820457A2
40-50	2	3.385 / .010	18-4633	700-834800A5, 700-819005A12, 700-834800A2	18-3999	39-820641A1
40-50	2	3.405 / .030	18-4634	700-834800A6	—	39-818129A2
85-90 & L-DRIVES	3	3.312 / STD.	18-4629	700-834794T3, FA691015	18-39010 ①	39-817869A1, FA663260
85-90 & L-DRIVES	3	3.322 / .010	18-4630	700-834794A4, 700-FSA694015	—	39-817869A2, FSA335260
85-90 & L-DRIVES	3	3.342 / .030	18-4631	700-834794A5, 700-818134A1	—	39-817869A3, 39-818110A1
90 L-DRIVE, SPORT JET	3	3.375 / STD.	18-4632	700-834800A4, 700-819005A8	18-3998 ①	39-8204757A2, FA528269, FA528260, 39-820457A1, 39-820457A2
90 L-DRIVE, SPORT JET	3	3.385 / .010	18-4633	700-834800A5, 700-819005A12, 700-834800A2	18-3999	39-820641A1
90 L-DRIVE, SPORT JET	3	3.405 / .030	18-4634	700-834800A6	—	39-818129A2
120-150	4	3.312 / STD.	18-4629	700-834794T3, FA691015, 700-F694015	18-39010 ①	39-817869A1, FA663260
120-150	4	3.322 / .010	18-4630	700-834794A4, 700-FSA694015	—	39-817869A2, FSA335260
120-150	4	3.342 / .030	18-4631	700-834794A5, 700-818134A1	—	39-817869A3, 39-818110A1
120 L-DRIVE, SPORT JET	4	3.375 / STD.	18-4632	700-834800A4, 700-819005A8	18-3998 ①	39-8204757A2, FA528269, FA528260, 39-820457A1, 39-820457A2
120 L-DRIVE, SPORT JET	4	3.385 / .010	18-4633	700-834800A5, 700-819005A12, 700-834800A2	18-3999	39-820641A1
120 L-DRIVE, SPORT JET	4	3.405 / .030	18-4634	700-834800A6	—	39-818129A2

① Keystone Rings

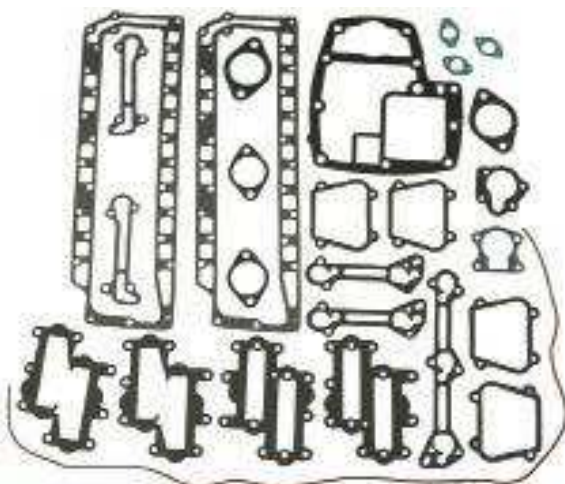

**18-4312 POWERHEAD GASKET SET**

Powerhead Gasket Sets Do Not Include Head Gaskets

— CONTAINS —

PART #	GASKET DESC.	O.E. #	QTY.
18-0968	Cyl. Drain Reed Plate	27-F84748-3	2
18-0861	Cyl. Drain Reed Plate	27-F85748-2	1
18-0869	Port Cover Gasket	27-F40223	4
18-0915	Deflector Plate	27-F406406	2
18-0854	Thermostat Cover	27-F476067	1
18-0958	Exhaust Plate	27F-372154	2
18-0960	Carburetor	27-F85906	2
18-0141	By-Pass	27-F85762	2
18-0315	Carburetor	27-F440906	2



**18-4313**

**POWERHEAD GASKET SET**

Powerhead Gasket Sets Do Not Include Head Gaskets

— CONTAINS —

PART #	GASKET DESC.	O.E. #	QTY.
18-0968	Cyl. Drain Reed Plate	27-F84748-3	1
18-0853	Manifold	27-F85159-1	1
18-0855	Carburetor Adapter Flange	27-F85168-1	3
18-0857	Cyl. Drain Cover	27-F85472-2	1
18-0861	Cyl. Drain Reed Plate	27-F85748-2	1
18-0869	Port Cover	27-F40223	2
18-0854	Thermostat Cover	27-F476067	1
18-0152	Intake	27F-481836	3
18-0119	Exhaust Port Plate	27-F85154	2
18-0114-1	Manifold End Cap	907761	1
18-7108	O-Ring	—	1
18-0960	Carburetor	27-F85906	3
18-0141	By-Pass	27-F85762	2
18-2534	Seal	184122-1	1

**CHRYSLER POWERHEAD GASKET SET APPLICATION**

HP	Years	Part #	HP	Years	Part #	HP	Years	Part #
45	1972-83 ①	—	85	1970-73, 1977-88	18-4313	120	1971-77	18-4312
50	1981-87	—	90	1974-77	18-4313	125	1983-88 ②	18-4312
55	1972-76 ①	—	100	1979-81, 1983	18-4312	130	1972	18-4312
70	1970-73, 1979-80	18-4313	105	1972-78, 1982	18-4312	135	1974-77	18-4312
75	1974-83	18-4313	115	1977-83	18-4312	140	1978-83	18-4312

① Beginning mid year 1972 All BC, BE, HC & HE Models

② For 1988 A & B Models

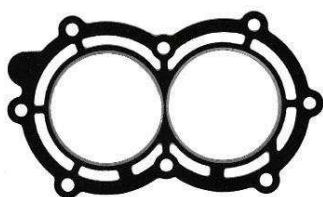

**18-3851  
HEAD GASKET**

Replaces: 27-F286529-3  
For: 9.9 and 15 HP

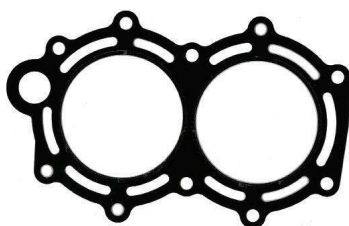

**18-3852  
HEAD GASKET**

Replaces: 27-F513529  
For: 25 and 35 HP

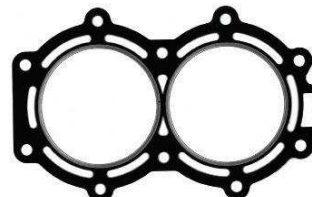

**18-3853  
HEAD GASKET**

Replaces: 27-F691529-1  
For: 45 and 50 HP

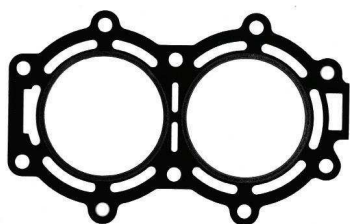

**18-3854  
HEAD GASKET**

Replaces: 27-F658529  
For: 50 HP



**18-3855  
HEAD GASKET**

Replaces: 27-820438  
For: 70, 75, 85 and 90 HP

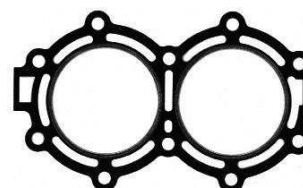

**18-3856  
HEAD GASKET**

Replaces: 27-F201529-1  
For: 1984-1987 "A" models 50 HP



**18-3857**  
**HEAD GASKET**  
 Replaces: 27-824615/27-824615-2, F476529,  
 F476529-1, F476529-2, 27-F476529-4  
 For: 100 thru 140 H.P.



**18-3859**  
**HEAD GASKET**  
 Replaces: 27-819138-2  
 For: 25 HP (E127700-E344999)

**HEAD GASKET APPLICATION**

HP	Model/Year	Serial #	Part No.	HP	Model/Year	Serial #	Part No.
9.9/15	1984-92,A,B	N/A	18-3851	90	1990-92,C,E	N/A	18-3855
9.9/15	1992-98	E000001 & UP	18-3851	90	1991-99	E000001 & UP	18-3855
25	1989A,B	N/A	18-3852	90	1990-91 L-DRIVE,A,B,C,D	N/A	18-3855
35	1986-91,A,B,C	N/A	18-3852	90	1993-95 SPORT JET	E023150-E138599	18-3855
40	1992C & 1992-99	E000001 & UP	18-3853	95	1996-97 SPORT JET XR	E141089 & UP	18-3855
50	1990A,1989-92,B,C,D,Z	N/A	18-3853	120	1990-92,A,C	N/A	18-3857
50	1984-87,A	N/A	18-3856	120	1990-99	E000001 & UP	18-3857
50	1988-89,A/1987-88,B,C,D	N/A	18-3854	120	1990-92,A,B,C,D L-DRIVE	N/A	18-3857
70	1991-92,B,C	N/A	18-3855	120	1995-99 SPORT JET,XR,XR2	N/A	18-3857
70	1992-95	E000001 & UP	18-3855	125	1983-89, A	N/A	18-3857
75	1996-99	E138600 & UP	18-3855	125	1986-89, B	N/A	18-3857
85	1984-89,A,L/1986-89,B,C,	N/A	18-3855	125	1988-89, C	N/A	18-3857
85	1986,M,N	N/A	18-3855	125	1989, D, E	N/A	18-3857
85	1985 L-DRIVE A,B,C	N/A	18-3855	150	1989A-1992C		N/A
85	1989,D,E,F,G,H	N/A	18-3855	150	1989-1994	E000001-E093699	N/A
90	1990-91,A,B,D	N/A	18-3855				

PKG. OF 2

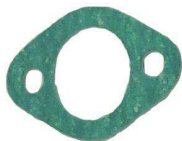

**18-0141**  
**18-0141-9<sup>①</sup>**  
**BYPASS GASKET**  
 Replaces: 27-F85762

PKG. OF 2



**18-0152**  
**18-0152-9<sup>①</sup>**  
**INTAKE GASKET**  
 Replaces: 27-F481836

PKG. OF 2



**18-0315**  
**18-0315-9<sup>①</sup>**  
**CARBURETOR GASKET**  
 Replaces: 27-F440906

PKG. OF 2

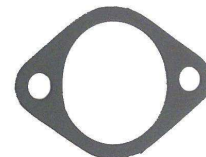

**18-0960**  
**18-0960-9<sup>①</sup>**  
**CARBURETOR**  
**MOUNTING GASKET**  
 Replaces: 27-F85906

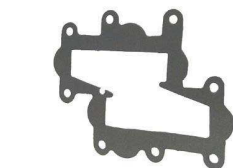

**18-0314**  
**CARBURETOR ADAPTER**  
**GASKET**  
 Replaces: 27-828316, 27-F178168,  
 27-F178168-1, F178168

PKG. OF 2

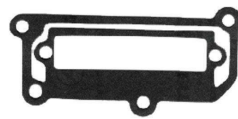

**18-0855**  
**18-0855-9<sup>①</sup>**  
**CARBURETOR ADAPTER**  
**FLANGE GASKET**  
 Replaces: 27-F85168-2

PKG. OF 2



**18-0915**  
**DEFLECTOR**  
**PLATE GASKET**  
 Replaces: 27-F406406



**18-0861**  
**CYLINDER DRAIN**  
**REED PLATE GASKET**  
 Replaces: 27-F85748-2

PKG. OF 2



**18-0119**  
**18-0119-9<sup>①</sup>**  
**EXHAUST**  
**PLATE GASKET**  
 Replaces: 27-F85154-1

PKG. OF 2



**18-0958**  
**EXHAUST**  
**PLATE GASKET**  
 Replaces: 27-F372154-1

PKG. OF 2



**18-0869**  
**18-0869-9<sup>①</sup>**  
**PORT COVER**  
**GASKET**  
 Replaces: 27-F40223, 27-820500A3





PKG. OF 2





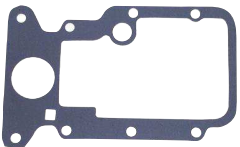

**18-0115**  
**18-0115-9<sup>①</sup>**  
**POWERHEAD**  
**BASE GASKET**  
 Replaces: 27-F307279-2

SEE PAGES 201-202 FOR OUR COMPLETE LINE OF GASKET SEALANTS

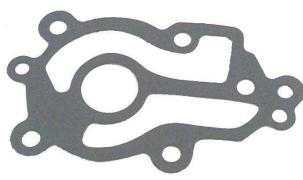
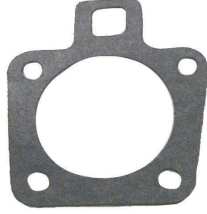
<sup>①</sup> Priced per Package

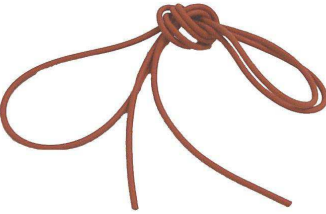
 <p><b>18-0154</b> <b>LOWER EXHAUST CYLINDER GASKET</b> Replaces: 27-F40279-1</p>	<p>PKG. OF 2</p>  <p><b>18-0854</b> <b>18-0854-9</b>① <b>THERMOSTAT COVER GASKET</b> Replaces: 27-F476067</p>	<p>PKG. OF 2</p>  <p><b>18-0873</b> <b>18-0873-9</b>① <b>THERMOSTAT GASKET</b> Replaces: 27-F97067, 27-819377</p>	 <p><b>18-0622</b> <b>LOWER WEAR PLATE GASKET</b> Replaces: 27-19701</p>
--	--	--	---

<p>PKG. OF 2</p>  <p><b>18-0415</b> <b>18-0415-9</b>① <b>WATER PUMP GASKET</b> Replaces: 27-F523031</p>	<p>PKG. OF 2</p>  <p><b>18-0416</b> <b>WEAR PLATE GASKET</b> Replaces: 27-F694830</p>	 <p><b>18-0417</b> <b>18-0417-9</b>① <b>WATER PUMP GASKET</b> Replaces: 27-F84031</p>
--	--	--

<p>PKG. OF 2</p>  <p><b>18-2534</b> <b>SEAL (40")</b> Replaces: F184122-1</p>	 <p><b>18-2370</b> <b>BEARING CARRIER</b> Replaces: 19291A3 For: Force 40/50 HP (1995-99), 70 HP (1991-95), 75 HP (1996-98), Mercury/Mariner 30/40 HP 2 cyl (9854537-OP016999), 30/40 4-stroke (OG760300-up), 40/50 HP/30Jet 3 cyl (9973100-up), 60 HP 3 cyl (OD000750-up), 60 HP 4-stroke 9973100-up</p>	<p>①<b>18-2375D</b> </p>  <p><b>18-2375</b> <b>DRAIN PLUG (MAGNET)</b> <b>18-23751-9</b>① (Package of 50 without gasket)</p>
---	---	---

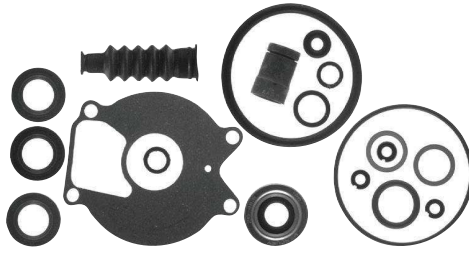

**18-2624**  
**LOWER UNIT SEAL KIT**  
Replaces: 26-85090A2

— CONTAINS —

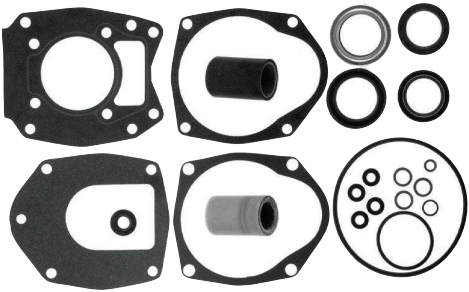

**18-2626**  
**LOWER UNIT SEAL KIT**  
Replaces: 26-43035A4

— CONTAINS —

PART #	DESC.	O.E. #	QTY.	PART #	DESC.	O.E. #	QTY.
18-0579	Oil Seal	26-41131	1	18-0522	Oil Seal	26-43036	1
18-0580	Oil Seal	26-41132	1	18-0583	Oil Seal	26-43035	1
18-0586	Seal	26-99325	2	18-2002	Oil Seal	26-76868	1
18-7419	O-Ring	25-69202	1	18-2053	Oil Seal	26-70081	1
18-2562	Gear Hsg to Face Plate Gasket	27-99326-1	1	18-2054	Oil Seal	26-816464	1
18-2945	Washer	12-20260	2	18-2563	Face Plate to Water Pump Cover Gasket	27-43034-1	1
18-2742	Boot	85552	1	18-2564	Water Pump Base to Face Plate Gasket	27-43033-1	1
18-2560	Washer	12-86645	2	18-2565	Water Pump Base to Gear Hsg Gasket	27-43047-2	1
18-7135	O-Ring	25-35276	1	18-2566	Face Plate to Water Pump Cover Gasket	27-817277	1
18-7956	O-Ring	25-85549	1	18-2945	Washer	12-19183	3
18-7100	O-Ring	25-85594	1	18-4261	Washer	19643	1
18-7959	O-Ring	25-99691	1	18-7198	O-Ring	25-45710	1

SEE PAGES 201-202 FOR OUR COMPLETE LINE OF GASKET SEALANTS

① Priced per Package

APPLICATION FOR SEAL KITS ON PAGE 238



**18-2629**  
**LOWER UNIT SEAL KIT**  
Replaces: 26-85090A1



**18-2630**  
**LOWER UNIT SEAL KIT**  
Replaces: FK1060



**18-2631**  
**LOWER UNIT SEAL KIT**  
Replaces: FK1061



**18-2632**  
**LOWER UNIT SEAL KIT**  
Replaces: FK1063-2, FK1063-1  
— CONTAINS —

PART #	DESC.	O.E. #	QTY.
18-2244	Washer	10-79953A2	3
18-7127	O-Ring	25-F84305	1
18-0500	Seal	26-817472	1
18-0512	Seal	26-F84307-1	1
18-7169	O-Ring	25-F24278	1
18-7176	O-Ring	25-90011	1
18-7467	O-Ring	25-54030	1
18-7141	O-Ring	802047	1



**18-2633**  
**LOWER UNIT SEAL KIT**  
Replaces: FK1127



**18-2635**  
**LOWER UNIT SEAL KIT**  
Replaces: 26-814669A2, 26-814669A1, FK1234  
— CONTAINS —

PART #	DESC.	O.E. #	QTY.
18-0500	Seal	26-817472	1
18-0622	Lower Wear Plate Gasket	27-19701	1
18-2051	Seal	26-69188	1
18-2052	Seal	26-69189	1
18-2945	Washer	12-19183	3
18-7168	O-Ring	25-48171	2
18-7173	O-Ring	25-30224	1
18-7950	O-Ring	25-45258	1

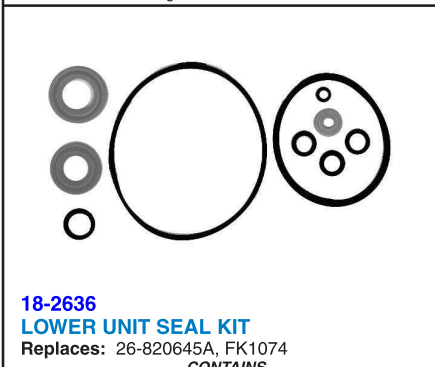

**18-2636**  
**LOWER UNIT SEAL KIT**  
Replaces: 26-820645A, FK1074  
— CONTAINS —

PART #	DESC.	O.E. #	QTY.
18-0500	Seal	26-817472	1
18-0502	Seal	26-819396	1
18-0503	Seal	26-F40307-2	1
18-2945	Washer	12-19183	2
18-7116	O-Ring	25-62704	1
18-7134	O-Ring	25-F40342	1
18-7141	O-Ring	25-25007	1
18-7952	O-Ring	25-88657	1



**18-2637-1**  
**LOWER UNIT SEAL KIT**  
Replaces: FK1064  
— CONTAINS —

PART #	DESC.	O.E. #	QTY.
18-0500	Seal	26-817472	1
18-0592	Seal	26-F318307	1
18-2945	Washer	12-19183	2
18-7149	O-Ring	25-525555	1
18-7171	O-Ring	25-F525305	1
18-7191	O-Ring	25-F474342	1



**18-2638**  
**LOWER UNIT SEAL KIT**  
Replaces: FK1065  
— CONTAINS —

PART #	DESC.	O.E. #	QTY.
18-0500	Seal	26-817472	1
18-0584	Seal	26-66022, 26-F346118	1
18-0593	Seal	26-F901307-2	2
18-0623	Lower Unit Gasket	27-F286555	1
18-2945	Washer	12-19183	3
18-7138	O-Ring	25-F455305	1

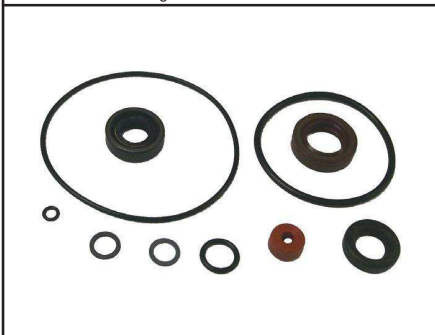

**18-2639**  
**LOWER UNIT SEAL KIT**  
Replaces: FK1068  
— CONTAINS —

PART #	DESC.	O.E. #	QTY.
18-0584	Seal	26-66022	1
18-2945	Washer	12-19183	2
18-7134	O-Ring	25-F498618	1
18-7141	O-Ring	25-25007	1
18-7176	O-Ring	25-90011	1

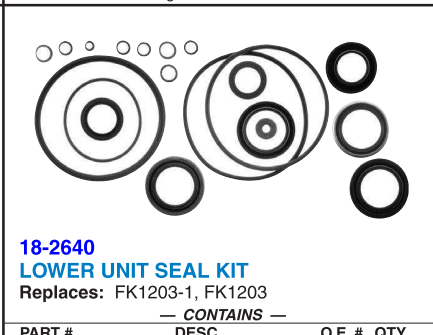

**18-2640**  
**LOWER UNIT SEAL KIT**  
Replaces: FK1203-1, FK1203  
— CONTAINS —

PART #	DESC.	O.E. #	QTY.
18-0500	Seal	26-817472	1
18-2014	Seal	26-F694305	1
18-2076	Seal	26-12224	1
18-2077	Seal	26-14077	1
18-2945	Washer	12-19183	3
18-7426	Grommet	25-30271	1
18-7127	O-Ring	25-F84305	1
18-7134	O-Ring	25-F498618	1
18-7169	O-Ring	25-F24278	1
18-7176	O-Ring	25-F74305	1
18-7413	O-Ring	25-62702	4



**18-2697-1**  
**LOWER UNIT SEAL KIT**  
Replaces: 26-41365A3  
— CONTAINS —

PART #	DESC.	O.E.#	QTY.
18-0581	Oil Seal	26-413651	2
18-0584	Oil Seal	26-66022	1
18-0585	Oil Seal	26-821928	1
18-0586	Oil Seal	26-99325	1
18-2728	Water Tube Seal	26-42102-1	1
18-2945	Washer	12-19183	2
18-3149-2	Water Pump Base	46-42040A5	1
18-4261	Washer	19643	1
18-7162	O-Ring	25-33145	1

APPLICATION ON NEXT PAGE

### CHRYSLER/FORCE LOWER UNIT SEAL KIT APPLICATION

Model / HP	Year	Seal Kit	Model / HP	Year	Seal Kit	Model / HP	Year	Seal Kit
6/7.5	1978-Up	18-2637	55	1972 1/2-1974	18-2636	85 L Drive	1989	18-2640
9.9/15	1997 & prior	18-2638	55 ②	1978-82	18-2630	90	1974-77	18-2631
9.9/15	1998	18-2697-1	55 ①	1983	18-2633	90	1983	18-2632
20/25	1972-78	18-2639	60 ②	1984 & Prior	18-2630	90	1990-94	18-2640
25	1989	18-2636	60 ①	1985	18-2633	90	1995-99	18-2626
25	1996-97	18-2624	65 ①	All	18-2633	90 L Drive	1990-91	18-2640
25	1998	18-2629	70	1970-73	18-2631	105	1970-76	18-2631
35	1970-72	18-2630	70	1979	18-2631	105	1979-83	18-2632
35	1972 1/2	18-2636	70	1991-95	18-2635	120	1990-94	18-2640
35	1973	18-2630	75	1975-79	18-2631	120	1995-99	18-2626
35	1974-75	18-2636	75	1980-83	18-2632	125 ③	1983-89	18-2632
35	1986-91	18-2639	75	1996-98	18-2635	125 D & E	1989	18-2640
35 B	1989-91	18-2636	75	1999	18-2626	125 L Drive	1989	18-2640
40	1992-94	18-2636	85	1980-89	18-2632	150	1989-94	18-2640
50	1984-94	18-2636	① With one piece lower units			② With two piece lower units		③ 1989 A,B,C Models Only

**⑥ 18-3701D** Display Package



**18-3701  
PROP NUT KIT**

— CONTAINS —

Part #	O.E. #	Description	QTY.
18-3200	F697140	Tab Washer	2
18-3700	F7000	Prop Nut	1



**18-4446  
PROP WRENCH KIT  
(18-4444 Wrench Only)**

— CONTAINS —

Part #	Desc.	QTY.
18-3200	Tab Washer	2
18-3700	Prop Nut	1
18-4444	Prop Wrench	1

### PROP NUT & TAB WASHER APPLICATION

HP	Year	Model Type	Tab Washer	Prop Nut	Prop Nut Kit
90 ④	1990	A	—	18-3700	—
90	1990	B, C	18-3200	18-3700	18-3701
90	1991	ALL	18-3200	18-3700	18-3701
90 L-Drive	1990	C	18-3200	18-3700	18-3701
90 L-Drive	1991	ALL	18-3200	18-3700	18-3701
120	1990	A	—	18-3700	—
120	1990	B,C	18-3200	18-3700	18-3701
120	1991	ALL	18-3200	18-3700	18-3701
120 L-Drive	1990	ALL	18-3200	18-3700	18-3701
120 L-Drive	1991	B,D	18-3200	18-3700	18-3701
125 L-Drive	1989	ALL	—	18-3700	—
150	1989	ALL	—	18-3700	—
150	1990	A	—	18-3700	—
150	1990	B, C, D	18-3200	18-3700	18-3701
150	1991	ALL	18-3200	18-3700	18-3701

④ 903F90A, X90A, 908F90A, X90A Models only.



**18-2254  
PROP SHAFT**  
Replaces: 44-850308



**18-3719  
PINION NUT**  
Replaces: 11-35921, 11-47411,  
11-826375, 11-F694188  
5/8" - 18 thread • 1 1/16" wrench



**18-1112**  
**REVERSE GEAR THRUST BEARING**  
 Replaces: 31-F523901



**18-1113**  
**REVERSE GEAR BEARING**  
 Replaces: 31-F523143

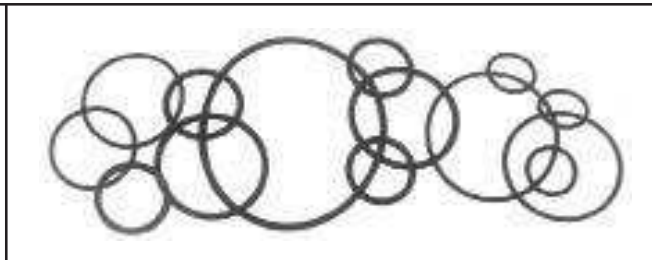

O-RINGS			
Part No.	O.E. No.	Dimensions	
		I.D.	Width
<a href="#">18-7120</a>	25-F498618	0.215	0.065
<a href="#">18-7127</a>	25-F84305, 25-32507, F83404	3.315	0.135
<a href="#">18-7134</a> ●⑦	25-20195, 25-201951	0.5	0.1
<a href="#">18-7169</a> ●⑦	25-F24278	3.5	0.135
<a href="#">18-7176</a> ●⑦	25-F74305	2.16	0.1
<a href="#">18-7457</a>	25-F455305	1.799	0.103
<a href="#">18-7950</a>	25-45258	9.843	0.984
<a href="#">18-7952</a> ●⑦	25-88657	2.4803	0.1378
<a href="#">18-7956</a> ●⑦	25-85549	2.4803	0.1969
<a href="#">18-7100</a> ●⑦	25-85594	0.2362	0.1575

● PKG OF 5



**18-79989**  
**TRAILERING STICKS**  
 Fits: Most outboards over 150hp with three ram intrigrel tilt/trim.



OIL SEALS					
Part No.	O.E. No.	Part No.	O.E. No.	Part No.	O.E. No.
<a href="#">18-0500</a>	26-817472	<a href="#">18-0580</a>	26-41132	<a href="#">18-0593</a>	26-F901307-2
<a href="#">18-0502</a>	26-819396	<a href="#">18-0583</a>	26-43035	<a href="#">18-8347</a>	26-8164641, 26-816464, 26-76384
<a href="#">18-0503</a>	26-F40307-2	<a href="#">18-0584</a>	26-66022, 26-F346118	<a href="#">18-8354</a>	26-828627
<a href="#">18-0512</a>	26-F84307-1	<a href="#">18-0586</a>	26-99325		
<a href="#">18-0579</a>	26-41131	<a href="#">18-0592</a>	26-F318307		



**THE VERY BEST PARTS OF BOATING**

