























<p>①18-5251D Display Package</p>  <p>18-5251 TUNE-UP KIT —CONTAINS— Part # Description 18-5314 Contact Set 18-5338 Condenser 18-5404 Rotor Mallory 8 cyl. Tall Cap</p>	<p>Display Package</p>  <p>18-5255 TUNE-UP KIT —CONTAINS— Part # Description 18-5303 Contact Set 18-5345 Condenser 18-5407 Rotor Prestolite 8 cyl.</p>	<p>①18-5258D Display Package</p>  <p>18-5258 TUNE-UP KIT —CONTAINS— Part # Description 18-5303 Contact Set 18-5347 Condenser 18-5407 Rotor Prestolite 8 cyl.</p>	 <p>18-5259 TUNE-UP KIT —CONTAINS— Part # Description 18-5303 Contact Set 18-5347 Condenser 18-5429 Rotor Prestolite 6 & 8 cyl.</p>	
<p>①18-5260D Display Package</p>  <p>18-5260 TUNE-UP KIT —CONTAINS— Part # Description 18-5303 Contact Set 18-5345 Condenser 18-5403 Rotor Prestolite 8 cyl.</p>	 <p>18-5303 CONTACT SET Replaces: 2421173, 2808870</p>	 <p>18-5307 CONTACT SET Replaces: 2084074, 1274092, 2421178</p>	 <p>18-5314 CONTACT SET Replaces: 2421820</p>	
 <p>18-5338 CONDENSER</p>	 <p>18-5345 CONDENSER Replaces: 2098058, 2279949</p>	 <p>18-5347 CONDENSER Replaces: 1818757, 3420600</p>	 <p>18-5403 ROTOR</p>	
 <p>18-5404-1 ROTOR Replaces: 868096</p>	 <p>18-5407 ROTOR Replaces: 1658535</p>	 <p>18-5429 ROTOR Replaces: 2098611</p>	 <p>18-5430 ROTOR Replaces: 868095</p>	 <p>18-5300 ROTOR Fits: Flamethrower Distributors</p>
 <p>18-5352 DISTRIBUTOR CAP Replaces: 4142817 Prestolite</p>	 <p>18-5369 DISTRIBUTOR CAP (With Gasket 18-5399) Replaces: 4142408 Prestolite</p>	 <p>18-5376 DISTRIBUTOR CAP Mallory</p>	 <p>18-5473 DISTRIBUTOR CAP Black Distributor Cap with Male Terminals for Flamethrower Distributors</p>	 <p>18-5474 DISTRIBUTOR CAP Red Distributor Cap with Male Terminals for Flamethrower Distributors</p>

① Items ending in "D" are Display Packaged - Regular number is Non-Display



**18-5301
TUNE-UP KIT**
Replaces:
Fits: male cap v-8 flamethrower distributors



**18-5302
TUNE-UP KIT**
Replaces:
Fits: male cap v-8 flamethrower distributors

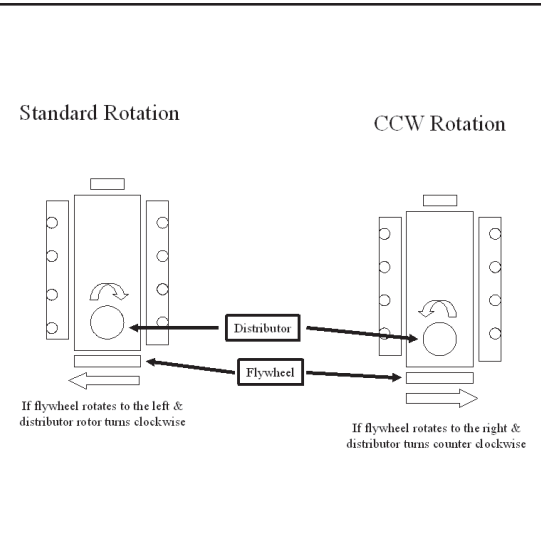

**18-5497-2
ELECTRONIC DISTRIBUTOR**
U.I. Approved • Conventional Rotation
For: Chrysler V-8 273, 318 (1967-Up), 340, 360 CID "LA" Engines

USES:

Part #	Description
18-5376	Distributor Cap
18-5404-1	Rotor
18-5491	Reluctor
18-5488	Module

PREMIUM MARINE SPARK PLUG WIRE LEADS

Sierra's MAGFORCE Ignition Wires are "Electronics Friendly" protecting all of your electronic devices and electronic engine controls from RFI and EMI while delivering the maximum amount of voltage. Exact fit design ensures easy installation and years of trouble - free service.

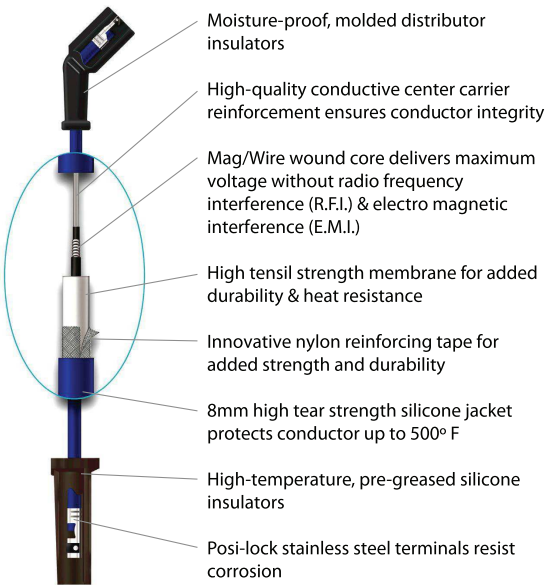

CHRYSLER MARINE IGNITION WIRES APPLICATION					
Engine	Cyl.	Distributor	Years	Year Stop	Plug Wire Set
M273	8	Conventional & Electronic	1968-1974	1974	18-8826-1
LM318	8	Conventional & Electronic	1968-1985	1985	18-8826-1
M340	8	Conventional & Electronic	1968-1985	1985	18-8826-1
M360	8	Conventional & Electronic	1975-1985	1985	18-8826-1
361	8	Conventional & Electronic	1968-1985	1985	18-8827-1
383	8	Conventional & Electronic	1960-1988	1988	18-8827-1
400	8	Conventional & Electronic	1968-1985	1985	18-8827-1
440	8	Conventional & Electronic	1968-1985	1985	18-8827-1

Ignitor® II
ELECTRONIC IGNITION

FEATURES

- *Senses current levels in the coil and adjusts the dwell to maintain peak energy throughout the entire RPM range.*
- *Develops, on average, 4 times more available energy between 3000 and 5000 RPM's and twice as much plug voltage as point-type systems.*
- *Ignition energy is sustained and coil life is increased when peak current level is reached just prior to spark.*
- *More stable timing.*
- *Use with [18-5472](#) "Flame Thrower II" Coil for optimum performance*



**18-5286
HI-PERFORMANCE
ELECTRONIC
CONVERSION KIT**
Fits: 6 Cylinder Delco Distributors



FEATURES

- ★ Replaces points & condensers for true solid state ignition.
- ★ Uses standard coil, cap and rotor.
- ★ Easy to install, one-piece, 2-wire hook-up.
- ★ Accurate to within 1/4° timing accuracy 0 to 6000 RPM range.
- ★ Can be used with Flame Thrower Coil **18-5469**

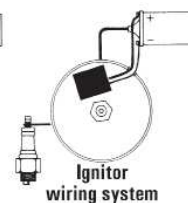
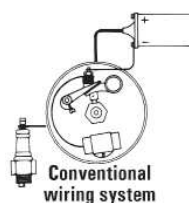

18-5294
ELECTRONIC CONVERSION KIT
Fits: 6 cyl. Delco distributors



18-5295
ELECTRONIC CONVERSION KIT
Fits: most 4 cyl. Prestolite distributors. (Except IBM 7026)
For: Onan, Universal, Waukesha, Wisconsin



18-5433
IGNITION COIL
Replaces: 201522, 2495531
Uses External Resistor



18-5435
IGNITION COIL
4.0 OHM
Replaces: 200691
Has Internal Resistor



FEATURES

- Oil filled for better cooling and long life
- Low resistance and improved turn ratios produces the higher voltage needed to run larger spark plug gaps for added power and better fuel economy
- More windings maximize energy and reliability over the full RPM range
- Fits existing brackets for easy installation

18-5469
HI-PERFORMANCE IGNITION COIL
3.0 ohm (oil filled), black - 4 & 6 cylinder:
Flame-Thrower 40,000 volt coil.
• Designed for use with the original Ignitor Electronic Conversion Kits
• Can be used with other inductive ignition systems



18-5472
HI-PERFORMANCE IGNITION COIL
0.6 ohm (oil filled), black - 4, 6, & 8 cylinder:
Flame-Thrower 45,000 volt coil.
• Super low 0.6 ohm resistance coil designed for use with the Ignitor II Hi Performance Electronic Conversion Kits
• Compatible with capacitive discharge systems



Sierra Part #	Description	Recommended Coil	Resistance Ohms
18-5294	Electronic Conversion Kit	18-5469	3.0
18-5295	Electronic Conversion Kit	18-5469	3.0
18-5286	Hi Performance Electronic Conversion Kit	18-5472	0.6

18-5450
COIL RESISTOR
15. OHM
Replaces: 4106140



18-5451
COIL RESISTOR
1.5 OHM & 3.0 OHM
Replaces: 3874767



18-5102
RELUCTOR
Replaces: 3656017





18-5493
IGNITION PICKUP
COIL ASSEMBLY
 Replacement pick-up coil for Accel Electronic Distributors



18-5103
IGNITION PICKUP
Replaces: 3780600



18-5105
IGNITION MODULE
Replaces: 3874020

STANDARD IGNITION

Year	Cyl.	Model	Distributor No.	Contact Set	Condenser	Rotor	Dist. Cap	Tune-Up Kit	Electronic Dist.
1949-60	6	M37, M47 (CROWN), M36	IAL-4004-1M, IGC-4510-1M	18-5307	18-5345 ③	18-5430	—	—	—
1955-60	8	M44 (IMPERIAL), M45 (ROYAL)	IBB-4102A	18-5303 ①	18-5347 ②	18-5404-1	—	—	—
1955-61	6	M49	IAO	18-5307	—	18-5430	—	—	—
1959-62	8	M80,81,M273X,M318,A,B,M413	IBM	18-5303	18-5347 ②	18-5407	18-5369	18-5258	18-5497-2 ④
1955-62	6	M36, M46, (ACE), M47 (CROWN), M46-3, 4, M49,TACK DRIVE	IAO-4109-1M, IAO-4113-1M	18-5307	18-5345 ③	18-5430	—	—	—
1961-65	6	M170,.225,MH225	2098748, 2444430	—	18-5347 ②	18-5430	—	—	—
1960-72	8	M80, 81, M273, A, B, X, M318A, B, C, X, M383, B, X, M413, B, D, E, M426, B, D, X, M426 HEMI	IBM-4106,08, A,B,C,09,A	18-5303	18-5347 ②	18-5407	18-5369	18-5258	—
1965-66	8	M318X	IBM-4120,5	18-5303	18-5347 ②	18-5429	—	18-5259	18-5497-2
1969-72	6	M225X	IBR-4205,A,AS	—	18-5347 ②	—	—	—	—
1970	8	M440X	IBB-4205	18-5303 ①	18-5347 ②	18-5407	18-5369	18-5258	—
1970	6	M265X	IAO-4114-1M	18-5307	18-5347 ②	18-5430	—	—	—
1960-72	8	M80, 80A, 81, 273X, 318A, B, C, X, M383, B, X, M413, B, D, E, M426B, D, X, M200, 225, 250, 260,300,335,440X	IBM-4108B, C,9A	18-5303	18-5347 ②	18-5407	18-5369	18-5258	18-5497-2 ④
1972-77	6	M225X	IBR-7002,A,AS,S	18-5307	18-5345 ③	18-5430	—	—	—
1973	8	ALL	IBB-7003,S	18-5303 ①	18-5345 ③	18-5407	18-5369	—	18-5497-2 ④
1976	8	M318	3675979	18-5303	18-5347 ②	18-5407	—	18-5258	18-5497-2
1971-82	8	M273, ML318, ML340, ML440	IBM-7001,2, 3,IBM-7003B,BS, 7004A,B,AS, BS	18-5303	18-5345 ③	18-5407	18-5369	—	18-5497-2 ④
1983-88	8	273, 318, 340, 440	IBM-7016,7017	18-5303	18-5347 ②	18-5403	18-5352	18-5260	18-5497-2 ④
1971	8	M273, M318	IBM-4122	18-5303	18-5347 ②	18-5407	18-5369	18-5258	18-5497-2

- ① Two (2) used
- ② For lead wire type use 18-5345
- ③ For strap type use 18-5347
- ④ Does not include Models 413, 426, 440 CID

B.I.D. ELECTRONIC IGNITION

Year	Model/Engine	Distributor	Reluctor	Pickup	Elect. Control Unit	Rotor	Distributor Cap
1972-82	M318,M340, 360, 440	IDH-7001, 2S	18-5102	18-5103	18-5105	18-5407	18-5369
1979-82	318,340, 360, 440	IDH-7002,S, 3,3A,3AS,3S	18-5102	18-5103	18-5105	18-5407	18-5369
1983-88	318,340, 360, 440	IDH-7004, 7005	18-5102	18-5103	18-5105	18-5403	18-5352
1983-88	318,340, 360, 440	IDH-7006,A	18-5102	18-5103	18-5105	18-5403	18-5352



18-5225
SPARK PLUG WIRE KIT
Replaces:
 Mercury 84-99215A26,
 84-813706A26
 Kit includes 25 ft. Roll of 7 MM Hypalon Ignition Wire With a Metallic Core and a Large Assortment of Three Different End Fittings to Fit Outboard Motors.



18-5226
IGNITION WIRE
Metallic Core
 100' Spool • 7mm Hypalon

PKG. OF 10



18-5224
18-5224-9①
SPARK PLUG WIRE TERMINAL
Replaces: Mercury 20121
OMC 510364

PKG. OF 10



18-5750
18-5750-9①
UNIVERSAL SPARK PLUG BOOTS
Supplied complete w/Terminal Connector
Replaces: OMC 581027, 580339



18-5752
UNIVERSAL SPARK PLUG BOOT
8mm



18-5840
SOLENOID
Replaces: Prestolite 15-79,
SAW4201, SAW4207, SAW4210



18-5841
SOLENOID
Replaces: 1692658
Prestolite



BATTERY CABLES
Gauge cable with soldered lug terminals on each end to accept a 3/8" stud.

Part #	Size	Color	Gauge	Part #	Size	Color	Gauge
BC88523	2'	red	4	BC88563	6'	red	2
BC88533	2'	black	4	BC88573	6'	black	2
BC88543	4'	red	2	BC88583	8'	red	1
BC88553	4'	black	2	BC88593	8'	black	1

① Priced per Package

BRUSH SET/STARTER SWITCH APPLICATION

Year/Model	Volt	Original Starter No.	Starter Switch
1960-88 LM318X,340X,M80A, 81,170A,M225A, X,M251X, 265X,273X,M318,A,B,C, X,M383BX,M413,B,D,E, X,M426B,D,E,X,M440, X,M155,200,225,250,260,300,335,375	12 12 12 12 12 12 12	MCL-6115 MDT-6010,11 MDT-7001,10 MDT-7002,14 MDT-7021,22 MDU-6003,10 MDU-7001	— 18-5840 18-5841 18-5840 — 18-5841 18-5841
1961-69 M225,MH225,M273,A,B, LM318,B,M318A,B,C, M383,B,X,M413,E,M426 B,D,X,M426 Hemi	12 12 12 12 12 12 12 12 12 6 & 12	MDT-6010,11 MDT-7002,14 2095150 1779955 2,095,393,509 2095509 MDT-7002,14 MDT-7001,10 MDT-7001,10	18-5841 18-5841 18-5841 18-5841 18-5841 18-5841 18-5841 18-5841 18-5841 18-5841
1959-69	12 12 12	MDU-6003,10 MDT-7001,10 MDT-7002	18-5841 18-5841 18-5841
1961-68	12	MDT-6010,11	18-5840
1961-65	12	MDU-7001	18-5841
1955-71 M26,46,46-4 (Ace),M27, 47,47-4, (Crown),M28, 36,37,38,44,44-3,48 (Royal)M45(Imperial), M45-3,46-3,47-3,M49	6 6 12 12 12 12	MCL-6102,M,07 MCL-6127,28,M MCL-6020M MCL-6115 MDT-6010,11M MDU-7013	— — — — 18-5840 —



18-9802
TIMING LIGHT
Self-powered accurate up to 10,000 RPM's



18-5710
VOLTAGE REGULATOR
Replaces: 2847527, 2098300 Prestolite
VSH-6201JY

Year/Model	Volt	Original	Alt/Gen. No.
1970-88 M273X,LM318X	12	ANE-5201S,2S,2YS	
1972-77 225,318X,340,X,400,440	12	3527502	

18-5723
VOLTAGE REGULATOR (Field Relay)
 Replaces: 2095946
 (Use with 18-5710)

Year/Model	Volt	Original Alt/Gen. No.
1961-70 B,D,X, M426 Hemi	12	2095860

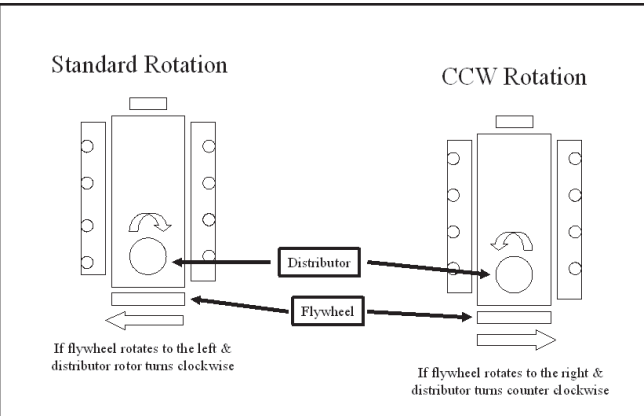

18-6270
PERMANENT MAGNET I/O STARTER
 Heavy Duty - 12 Volt
 2 Bolt Mount - 1 Threaded Hole - CW Rotation
Fits: Ford 460
 Permanent Magnet I/O

18-6835
STARTER
Replaces: GM Engines Universal
 Used on all GM Engines with either 14 1/4" or 12 3/4" flywheels

18-5954
ALTERNATOR
Replaces: 3527501, 3527502, 3744870
 61 Amps

18-7089
CARB KIT

18-7091
CARB KIT

18-7095
CARB KIT

18-7725
CARB KIT

18-7726
CARB KIT

18-7201
FLOAT
 (Alcohol Resistant)
 Brass

CARBURETOR KIT / FLOAT APPLICATION

Years	Cyl.	Model or Engine Displacement	Mfg. Code	Carb. Model	Carburetor Number	Float	Carb. Kit ①
1965 -Up	8	M-273-B,LM-318-B, M-340-B, M-360-B,M383-B,M-440-B	C-4	AFB	3980, 6130, 6212	—	18-7089
1965-69	8	M-318-B,M-383, M-413,M-426, M-440	C-4	AFB	3213, 3214, 3392, 3543, 4476, 4699, 9263, 9264	—	18-7091
—	8	318" (5.2L), 360" (5.9L)	R-4	4MV	17084001, 17086115, 17086116	18-7201	18-7095
—	8	M-80, M-81 318" (5.2L), 361" (5.9L) (2 Carb. Installation)	C-1	YH	2911, 3035, 3195	—	18-7725
—	6	M-225, M-225D, MH-225	C-2	BBD	3389, 3390, 4268	—	18-7726
—	8	M273A, M318A, M318G	C-2	BBD	3212, 3979, 3981	—	18-7726

① Does not include Metering Rods.

ALL SIERRA FUEL PUMPS INCLUDE MOUNTING GASKET

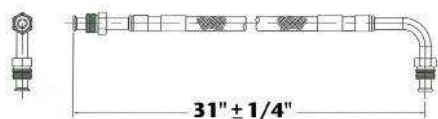

18-8114
FUEL LINE HOSE
UNIVERSAL

For fuel pump to carburetor connection. Replaces copper or steel tubing 3/8" X 31" PTFE composite hose with 5/8"-18 male inverted flare straight one end, 5/8"-18 90° one end. SAE J1527 type A1

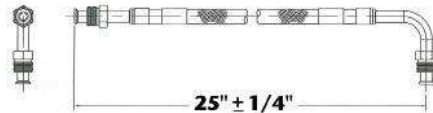

18-8115
FUEL LINE HOSE
UNIVERSAL

For fuel pump to carburetor connection. Replaces copper or steel tubing 3/8" X 25" PTFE composite hose with 5/8"-18 male inverted flare straight one end, 5/8"-18 90° one end. SAE J1527 type A1





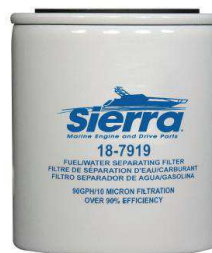



FUEL WATER SEPARATORS

















Sierra offers a complete line of 10 and 21 micron fuel water separating filters including drainable bowl filters to protect your carbureted and fuel injected engine.

Refer to pages 136-140 for a complete listing of OEM and universal applications.

Sierra fuel water separators remove over 99.8% of emulsified water from your gasoline. Sierra's 10 micron filters are over 90% efficient at removing particles as small as 10 micron. All filters flow @ 90 GPH to feed even the hungriest motor. Sierra 10 micron filters are recommended to prevent damage to sensitive inboard and outboard fuel injection systems.

Sierra #	Chrysler #	Description
18-7964-1	—	Transmission Filter
 18-7230 FLAME ARRESTOR Replaces: 4142886 Ht. 2.250 Element 1.470 Throat 5.050 1 Vent Tube	 18-7254 FUEL PUMP Replaces: 3745414 (Flange I.D. #6766, M6766) For: (V-8) 318,360	 18-7255 FUEL PUMP Replaces: 3745415 (Flange I.D. #6767, M6767) For: (V-8) 361, 400, 413, 440
 18-7264 FUEL PUMP Replaces: 2279913, 1736073 (Flange I.D. #40781, M6866) For: (V-8) 273, 318, 340, 360	 18-3551 THERMOSTAT Replaces: 4142885 142° 2.125 O.D. x 1.500 H	 18-3645 THERMOSTAT Replaces: 2463441 For: 318 & 360 CID Engines 160°

 <p>18-3047 IMPELLER KIT Contains: 18-3061 Impeller</p>	 <p>18-3060 IMPELLER Replaces: Sherwood 9959</p>	<div style="text-align: right;"> ① 18-3046D Display Package </div>  <p>18-3046 IMPELLER KIT Replaces: Sherwood 9959K Contains: 18-3060 Impeller</p>									
 <p>18-3061 IMPELLER Replaces: Sherwood 10615 For: GM engines with V-Belt</p>	 <p>18-3168 SEAL & SEAT Replaces: Sherwood 10927 For: 318 CID Engines (1975-77) & 360 CID Engines (1975)</p>	 <p>18-3581 CIRCULATING WATER PUMP (Bi-Directional) Replaces: 3004886, 3745985, 3619542, 4417905 For: Engine Models 318, 340 & 360</p>	 <p>18-3582 CIRCULATING WATER PUMP Replaces: 3619859 For: 383,400,440</p>								
<div style="text-align: right;"> ② 18-4456D Display Package </div>  <p>18-4456 EXHAUST PROTECTOR VALVE Includes Stainless Steel Clamp 3"</p>	<div style="text-align: right;"> ② 18-4457D Display Package </div>  <p>18-4457 EXHAUST PROTECTOR VALVE Includes Stainless Steel Clamp 4"</p>	<div style="text-align: right;"> ② 18-4458D Display Package </div>  <p>18-4458 EXHAUST PROTECTOR VALVE Includes Stainless Steel Clamp 5" & 6" (5" requires two 45° cuts)</p>									
<h2 style="text-align: center;">OIL FILTERS</h2> <table border="1" style="width: 100%; border-collapse: collapse; margin-top: 10px;"> <thead> <tr> <th style="background-color: #333; color: white;">Part #</th> <th style="background-color: #333; color: white;">Replaces:</th> </tr> </thead> <tbody> <tr> <td style="background-color: #e0e0e0;">18-7875</td> <td style="background-color: #e0e0e0;">1851658, 56874, F724002 (Long)</td> </tr> <tr> <td style="background-color: #e0e0e0;">18-7878-1</td> <td style="background-color: #e0e0e0;">L-19, L-1008, 3549957 (Short)</td> </tr> <tr> <td style="background-color: #e0e0e0;">18-7879-1</td> <td style="background-color: #e0e0e0;">L-319</td> </tr> </tbody> </table> <p style="background-color: #333; color: white; padding: 5px; text-align: center; margin-top: 10px;">SEE PAGES 182-184 & 1147-1170 FOR ADDITIONAL INFORMATION</p>		Part #	Replaces:	18-7875	1851658, 56874, F724002 (Long)	18-7878-1	L-19, L-1008, 3549957 (Short)	18-7879-1	L-319	<div style="text-align: right;"> Display Package </div> 	 <p>18-3878 HEAD GASKET Replaces: 4417375</p>
Part #	Replaces:										
18-7875	1851658, 56874, F724002 (Long)										
18-7878-1	L-19, L-1008, 3549957 (Short)										
18-7879-1	L-319										
 <p>18-3860 HEAD GASKET Replaces: 4142880 For: 318 CID Engines</p>	 <p>18-0609 VALVE COVER GASKET Replaces: 4273129 For: 318/340/360 CID</p>	<p>PKG. OF 2</p>  <p>18-0499 18-0499-9 WATER PUMP PLATE GASKET Replaces: 10612</p>									

① Priced per Package

② Items ending in "D" are Display Packaged - Regular number is Non-Display

**Fits Chrysler Small Block V8 318-360 cu. in.
All Models 1966 & up with Fixed Exhaust**

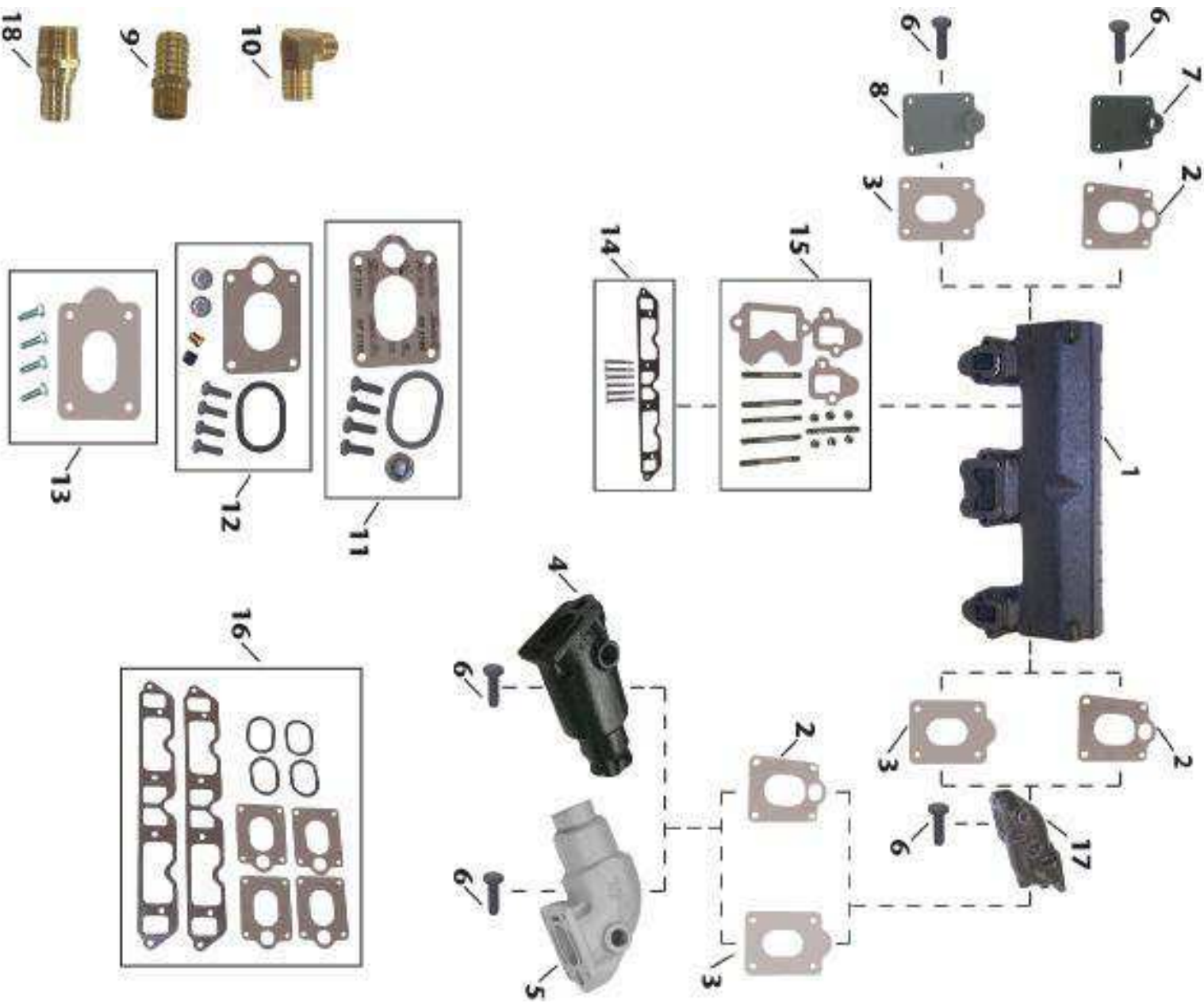

Item No.	Description	OE No.	Application
1	18-1940 MANIFOLD	4142322, 3675826	Chrysler Models 318-360CID Engines (1966 & Up); Use manifold mounting kit 18-8526 or 18-8527 (stainless).
2	18-2941 END CAP GASKET (OPEN)	2847480, 2469559	Fits: End Caps of Manifold (Starboard & Port) 18-1940; Risers: 18-1945; Elbows: 18-1946 & 18-1913
3	18-0472-1 END CAP GASKET (BLOCKED)	N/A	Fits: End Caps of Manifold (Starboard & Port) 18-1940; Risers: 18-1945; Elbows: 18-1946 & 18-1913
4	18-1946 MANIFOLD ELBOW	3527794	Use in conjunction with 18-1945. 3" exhaust outlet & a 20° down angle.
5	18-1913 MANIFOLD ELBOW	2469639, 2847405	Use in conjunction with 18-1945. 3" exhaust outlet & a 90° down angle.
6	NSS MOUNTING BOLT	N/A	Included in 18-4360, 18-4361, & 18-8506 mounting kits.
7	18-1942 MANIFOLD END PLATE (OPEN)	2846106	Use with End Plate Gasket: 18-2941 (Open); Mounting Kit: 18-4360 (Open) or 18-4361 (Open); (Port & Starboard) Manifold: 18-1940
8	18-1941 MANIFOLD END PLATE (BLOCKED)	2469556, 3675826	Use with End Plate Gasket: 18-2941; Mounting Kit: 18-4360 or 18-4361; (Port & Starboard) Manifold: 18-1940
9	18-4461 HOSE FITTING	N/A	3/4" - 14NPT X 1" Hose (Corrosion Resistant Brass Fitting)
10	18-8216 HOSE FITTING	N/A	3/4" - 14 NPT x 1" Hose (Corrosion Resistant Brass Fitting)
11	18-4360 MOUNTING PACKAGE (OPEN GASKET)	N/A	Use with End Plates: 18-1942 (open) or 18-1941 (Blocked); Riser/Elbow: 18-1945, 18-1946, 18-1913
12	18-4361 MOUNTING PACKAGE (OPEN GASKET)	N/A	Use with End Plates: 18-1942 (open) or 18-1941 (Blocked); Riser/Elbow: 18-1945, 18-1946, 18-1913
13	18-8506 MOUNTING KIT (BLOCKED GASKET)	N/A	Use with Riser/Elbow: 18-1945, 18-1946, 18-1913; End Plate: 18-1941 (Blocked)
14	18-8526 MOUNTING KIT	N/A	Use with Manifold: 18-1940
15	18-8527 MOUNTING KIT (STAINLESS STEEL)	N/A	Use with Manifold: 18-1940 (Kit has stainless steel studs and nuts)
16	18-4346 EXHAUST MANIFOLD GASKET SET	3745220	318 CID Engines (1969-85)
17	18-1945 MANIFOLD RISER	2846689	Use with Manifold: 18-1940; Riser Gasket: 18-2941 (Open) or 18-0472-1 (Closed); Mounting Kit: 18-4361 (Open) or 18-4360 (Open) or 18-8506 (Blocked)
18	18-8215 HOSE FITTING	N/A	3/4" - 14NPT X 3/4" Hose (Corrosion Resistant Brass Fitting)



**Fits Chrysler Big Block V8 383-440 cu. in.
All Models Except 413 "E" with Staggered Bolt Pattern**

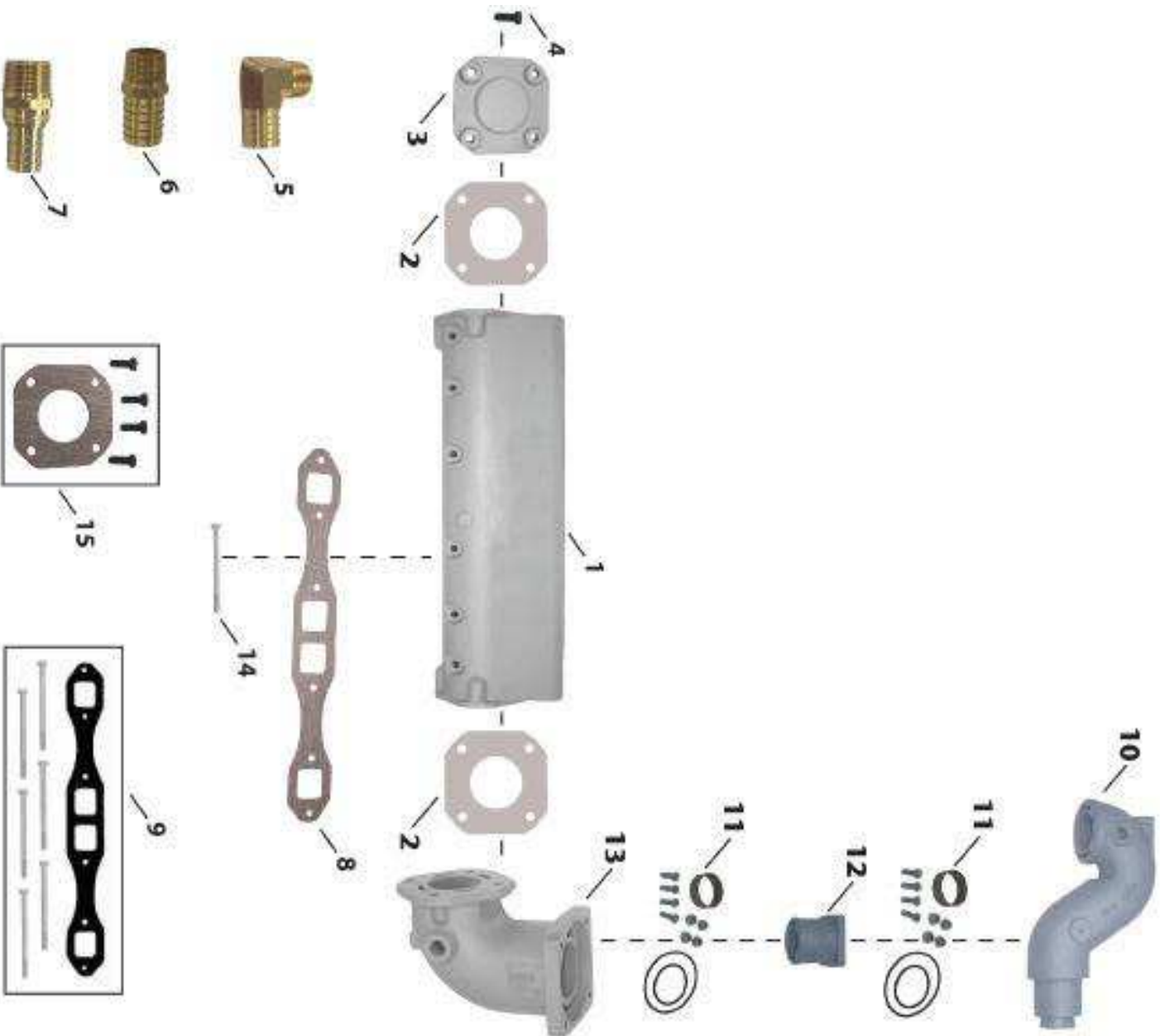

Item No.	Description	OE No.	Application
1	NSS MANIFOLD	E7081M, 3619659	Chrysler Models 383-440 cu.in. (V8 Big Block). Use with Manifold Gasket: 18-0474-1 ; Front Plate: 18-1911
2	18-0471 ELBOW GASKET	N/A	Gasket for Elbow: 18-1948 ; End Plate: 18-1911
3	18-1911 END/FRONT PLATE	N/A	Use with Elbow Gasket: 18-0471 , &/or Mounting Kit: 18-8501
4	NSS MOUNTING BOLT	N/A	Included in 18-8501 mounting kit.
5	18-8216 HOSE FITTING	N/A	3/4" - 14 NPT x 1" Hose (Corrosion Resistant Brass Fitting)
6	18-4461 HOSE FITTING	N/A	3/4" - 14NPT X 1" Hose (Corrosion Resistant Brass Fitting)
7	18-8215 HOSE FITTING	N/A	3/4" - 14NPT X 3/4" Hose (Corrosion Resistant Brass Fitting)
8	18-0474-1 MANIFOLD GASKET	N/A	
9	NSS MOUNTING KIT	N/A	Big Block (V8) 383-440 cu.in. (All models except 413"E" with offset bolt pattern) Includes 18-0474-1 Manifold Gasket
10	18-1944 RISER	2847404, 2847623, 3745639, E9923M	Use with Manifold: 18-1940 ; Mounting Kit: 18-8518
11	18-8518 MOUNTING KIT	N/A	Use with Riser: 18-1944 .
12	N/A EXTENSION	N/A	Use in conjunction with 18-1948 . Use mounting kit: 18-8518 .
13	18-1948 RISER	E9234M	Use with 18-8501 mounting kit.
14	NSS MOUNTING BOLT	N/A	
15	18-8501 MOUNTING KIT	N/A	Used with Front Plate: 18-1911 ; Elbow: 18-1948



**Fits Chrysler Small Block V8 318-360 cu. in.
All Models 1966 & up with Swivel Exhaust**

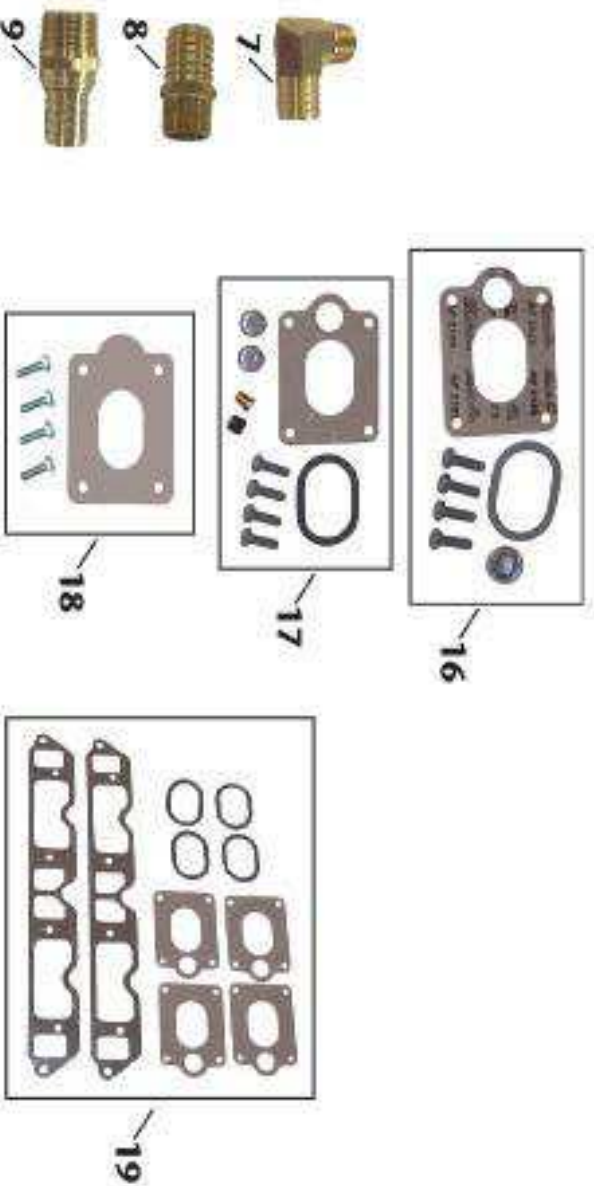
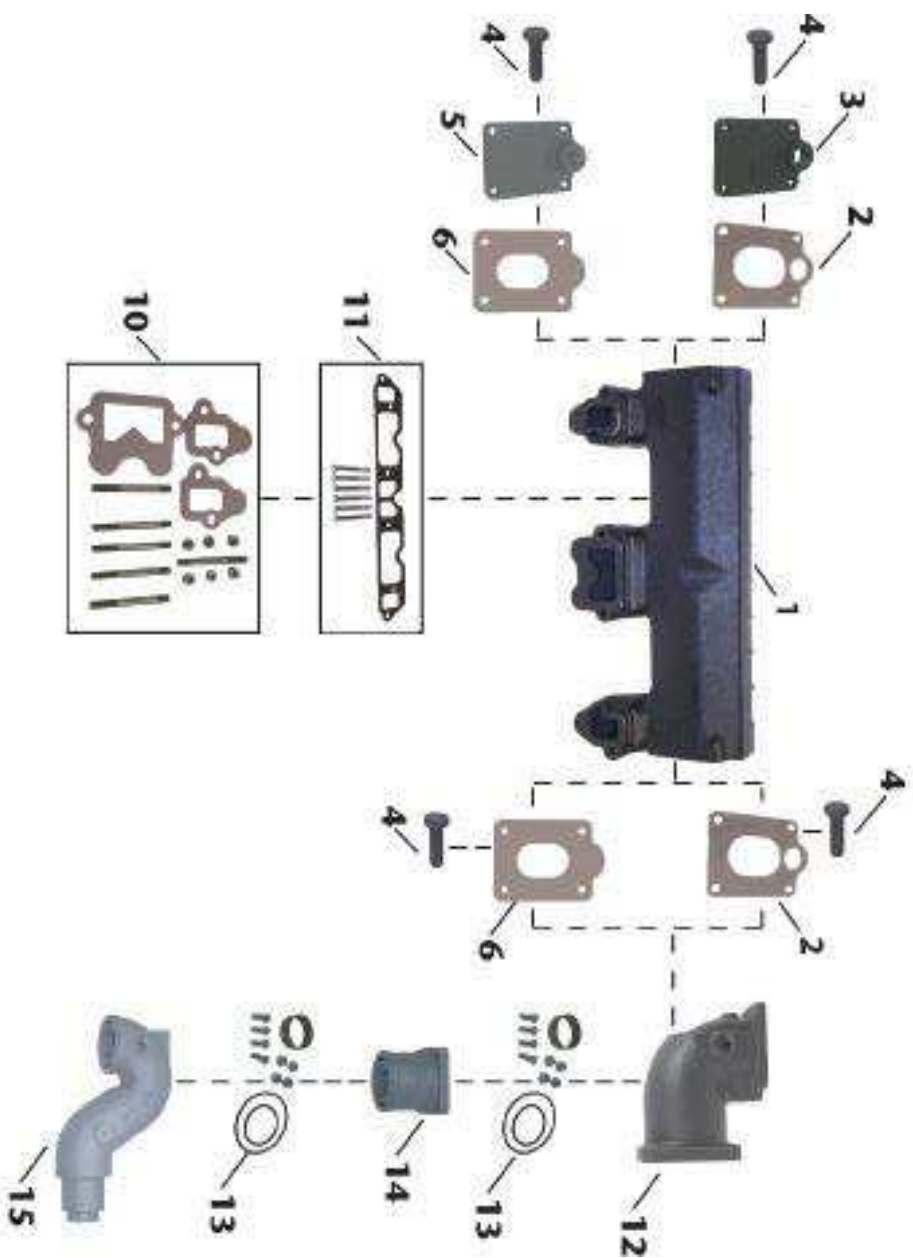

Item No.	Description	OE No.	Application
1	18-1940 MANIFOLD	4142322, 3675826	Chrysler Models 318-360CID Engines (1966 & Up); Use manifold mounting kit 18-8526 or 18-8527
2	18-2941 END CAP GASKET (OPEN)	2847480, 2469559	Fits: End Caps of Manifold (Starboard & Port) 18-1940. Included in 18-4360, & 18-4361 mounting kits.
3	18-1942 MANIFOLD END PLATE	2469556, 3675826	Use with End Plate Gasket: 18-2941; Mounting Kit: 18-4360 or 18-4361
4	NSS MOUNTING BOLT	N/A	Included in 18-4360, 18-4361, & 18-8506 mounting kits.
5	18-1941 MANIFOLD END PLATE	2846106	Use with End Plate Gasket: 18-0472-1 ; Mounting Kit: 18-8506
6	18-0472-1 END CAP GASKET (BLOCKED)	N/A	Fits: End Caps of Manifold (Starboard & Port) 18-1940. Included in 18-8506 mounting kit.
7	18-8216 HOSE FITTING	N/A	3/4" - 14 NPT x 1" Hose (Corrosion Resistant Brass Fitting)
8	18-4461 HOSE FITTING	N/A	3/4" - 14NPT X 1" Hose (Corrosion Resistant Brass Fitting)
9	18-8215 HOSE FITTING	N/A	3/4" - 14NPT X 3/4" Hose (Corrosion Resistant Brass Fitting)
10	18-8527 MOUNTING KIT (STAINLESS STEEL)	N/A	Use with Manifold: 18-1940 (Kit has stainless steel studs and nuts)
11	18-8526 MOUNTING KIT	N/A	Use with Manifold: 18-1940
12	N/A ELBOW	2600402	Use with Manifold: 18-1940. Use mounting kit 18-4360, 18-4361, or 18-8506.
13	18-8518 MOUNTING KIT	N/A	Use with Riser: 18-1944
14	N/A EXTENSION	N/A	Use mounting kit: 18-8518.
15	18-1944 RISER	N/A	Use with Manifold: 18-1940. Use with mounting kit: 18-8518
16	18-4360 MOUNTING PACKAGE (OPEN GASKET)	N/A	Use with End Plates: 18-1942 (open) or 18-1941 (Blocked).
17	18-4361 MOUNTING PACKAGE (OPEN GASKET)	N/A	Use with End Plates: 18-1942 (open) or 18-1941 (Blocked).
18	18-8506 MOUNTING KIT (BLOCKED GASKET)	N/A	Use with End Plate: 18-1941 (Blocked).
19	18-4346 EXHAUST MANIFOLD GASKET SET	3745220	318 CID Engines (1969-85)



**ALL SIERRA MANIFOLDS ARE
PAINTED, PACKAGED AND LEAK TESTED**

18-1940

MANIFOLD

Port & Starboard

Replaces: 4142322, 3675826

Barr CM-1-6677A

Fits: Chrysler Model 273, 318, 340 & 360
CID engines (1973-1986)

Use with:

End Cap Gasket: **18-2941** Open or **18-0472-1** Blocked

Mounting Kit: **18-4360** Open or **18-4361** Open or **18-8506** Blocked

End Plate: **18-1941** Blocked or **18-1942** Open

Note: If using a blocked end plate either gasket will work. If using an open end plate use only an open gasket.



18-1997-1

MANIFOLD

Port & Starboard

Replaces: Barr CHV-1-83

Universal Center Riser Manifold

FITS:

Chriscraft 283, 302, 307 and 350 CID engines

Crusader 283 and 327 CID engines thru 1964; 305, 307 and 350 CID
engines 1965 and later

Daytona 200-283 and 300-327

Flagship 283, 327 and 350 CID engines

Pacer 305, 307 and 350 CID engines 1965 and later

Mercury 190, 198, 225, 250, 270, 228, 898, 260, 255 and 280 models

OMC 283, 305, 307 and 350 CID engines 1968-1980

Volvo 307 and 350 CID engines

Use **18-0604** Exhaust Manifold Gasket Set

*For Exploded View - See Pages 638-639



18-1898

MANIFOLD

Port & Starboard

Replaces: Barr CHVA-1-84, Marine Power 0991-110

Fits: 454 cu.in. GM big block V8 engines

Use with:

Exhaust Manifold Gasket: **18-0418**

*For Exploded View - See Pages 636-637



18-1945

RISER

Replaces: 2846689, Barr CM-20-6674

Fits: Chrysler Model 273, 318,
340 & 360 CID engines (1966-1986)

Use with:

Manifold: **18-1940**

Riser Gasket: **18-2941** open or **18-0472-1** blocked

Mounting Kit: **18-4361** open or **18-4360** open or **18-8506** blocked



18-1939

RISER

Replaces: Barr 20-0100, Marine Power 0992-593

Barr, Indmar and Marine Power Ford Small Block V8 302-351 cu.in., GM Small Block
V8 305-350cu.in., GM Big Block V8 454cu.in.

Use with:

Manifold: **18-1997-1** or **18-1998-1** or **18-1898**

Riser Gasket: **18-2854-1** open or **18-0476-1** blocked

Mounting Kit: **18-4364** open or **18-8535** blocked



18-1944

RISER

Replaces: 2847404, 2847623,
3745639, E9923M

Barr CM-20-414211
Chrysler Small Block V8 318-360cu.in.
(All models 1966 and up with swivel exhaust),
Big Block V8 383-440cu.in. (All models except
413"E" with offset bolt pattern)

Use with:

Manifold: **18-1940**

Mounting Kit: **18-8518**



18-1907

RISER

Replaces: Barr 20-0102, Indmar 53-2009, 53-2018

Barr and Indmar Ford Small Block V8 302-351cu.in.

Use with:

Manifold: **18-1997-1** or **18-1998-1**

Riser Gasket: **18-2854-1** open or **18-0476-1** blocked

Mounting Kit: **18-4364** open or **18-8535** blocked



18-1946

ELBOW

Replaces: 3527794

Barr CM-20-6672
Fits: Chrysler Model 273, 318,
340 & 360 CID engines (1966-1986)

will work in conjunction with **18-1945**

Use with:

Manifold: **18-1940**

Elbow Gasket: **18-2941** open or **18-0472-1** blocked

Mounting Kit: **18-4360** open or **18-4361** open or **18-8506** blocked

20°



**18-1913
ELBOW**
Replaces: Chrysler 2469556, 2469639, 2847405
 Chrysler Small Block V8 318-360 cu.in.
 (All Models 1966 and up with fixed exhaust)
 For: 18-1940 Manifold will work in conjunction with 18-1945
Use with:
 Elbow Gasket: 18-2941 open or 18-0472-1 blocked
 Mounting Kit: 18-4360 open or 18-4361 open or 18-8506 blocked



**18-1948
ELBOW**
Replaces: Chrysler E9234M
 Barr CM-20-9234
 Chrysler Big Block V8 383-440cu.in.
 (All Models except 413"E" with offset bolt pattern)
Use with:
 Elbow Gasket: 18-0471
 Mounting Kit: 18-8501



**18-1911
MANIFOLD END PLATE**
 Chrysler Big Block V8 383-440cu.in.
 (All Models except 413"E" w/offset bolt pattern)
Used with:
 Front/End Plate Gasket: 18-0471
 Mounting Kit: 18-8501



**18-1941
MANIFOLD END PLATE**
Replaces: 2846106
 Barr CM-1-6672-B
Use with:
 End Plate Gasket: 18-2941 open or 18-0472-1 blocked
 Mounting Kit: 18-4360 open or 18-4361 open or 18-8506 blocked



**18-1942
MANIFOLD END PLATE
with hole**
Replaces: 24695566, 3675826
 Barr CM-1-6672-H
Use with:
 End Plate Gasket: 18-2941
 Mounting Kit: 18-4360 or 18-4361
Fits: 18-1940 Manifold



**18-0607
INTAKE MANIFOLD GASKET SET**
Replaces: 3745217
For: 318 CID Engines (1969-82)

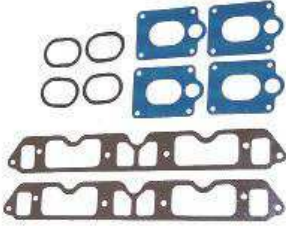

**18-4346
EXHAUST MANIFOLD GASKET SET**
Replaces: 3745220
For: 318 CID Engines (1969-85)



**18-0474-1
MANIFOLD GASKET**



**18-0471
ELBOW GASKET**
Used with:
 Elbow: 18-1948
 End Plate: 18-1911



**18-0472-1 (Blocked)
ELBOW GASKET**
Used with:
 Riser/Elbow: 18-1945, 18-1946, 18-1913
 End Plate: 18-1941



**18-0956-1
EXHAUST MANIFOLD
GASKET**
Replaces: 118-614
For: 460 CID



**18-4360 (Open)
EXHAUST ELBOW MOUNTING KIT**
 Barr CM206672JP
Use with
 Exhaust Elbow: 18-1946, 18-1913, 18-1945
 End Plate: 18-1942 open or 18-1941 blocked



**18-4361 (Open)
EXHAUST ELBOW MOUNTING KIT**
 Barr CM-20-6674P
Use with:
 End Plate: 18-1942 open or 18-1941 blocked
 Riser: 18-1945
 Elbow: 18-1946, 18-1913

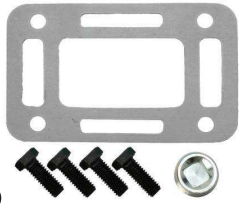

18-4364 (Open)
EXHAUST ELBOW KIT
 Replaces: Barr 20-0082-P
 Use with:
 Riser: 18-1999, 18-1907, 18-1939

PKG. OF 2



18-2941 (Open)
18-2941-9 ①
END CAP GASKET
 Replaces:
 2847480, 2469559
 Use with:
 End Plate: 18-1941, 18-1942
 Riser/Elbow: 18-1945, 18-1946, 18-1913
 For: 318CID Engines



18-8501
EXHAUST ELBOW MOUNTING KIT
 Barr CM-20-9234 P
 Chrysler Big Block V8 383-440 cu.in.
 (Models: All except 413 "E" with offset bolt pattern)
 Used with:
 Front Plate: 18-1911
 Elbow: 18-1948

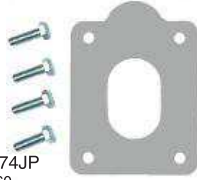

18-8506
EXHAUST ELBOW MOUNTING KIT
 Replaces: Barr CM-20-6674JP
 Chrysler Small Block V8 318-360 cu.in. (All models 1966 and up with swivel and fixed exhaust)
 Used with:
 Riser: 18-1945
 Elbow: 18-1946, 18-1913
 End Plate: 18-1941 blocked



18-8518
EXHAUST ELBOW MOUNTING KIT
 Replaces: Barr CM-20-9232P
 Chrysler Small Block V8 318-360cu.in. (All models 1966 and up with swivel exhaust), Big Block V8 383-440cu.in. (All models except 413 "E" with offset bolt pattern)
 Used with:
 Riser: 18-1944



18-8526
EXHAUST MANIFOLD MOUNTING KIT
 Chrysler Small Block V8 318-360cu.in.
 (All models 1966 and up with swivel and fixed exhaust)
 Used with:
 Manifold: 18-1940



18-8527
EXHAUST MANIFOLD MOUNTING KIT
 Replaces: Barr CM-1-6677SS P
 Chrysler Small Block V8 318-360cu.in.
 (All models 1966 and up with swivel and fixed exhaust)
 Used with:
 Manifold: 18-1940
 (Kit has stainless steel studs and nuts)



18-8535
EXHAUST ELBOW MOUNTING KIT
 Barr, Indmar and Marine Power
 Ford Small Block V8 302-351cu.in.,
 GM Small Block V8 305-350cu.in.,
 GM Big Block V8 454cu.in.
 Used with:
 Risers: 18-1939, 18-1999, and 18-1907



18-8536
EXHAUST ELBOW MOUNTING KIT
 Barr, Indmar and Marine Power GM Small Block V8 305-350cu.in.
 Used with:
 Manifold: 18-1997-1



PIPE PLUGS

Part #	Thread Size	Part #	Thread Size
18-4256	1/4"	18-4263	1/8" - 27 NPT
18-4257	1/4"	18-4264	3/8" - 18 NPT
18-4258	3/4"		

56507 Pipe Sealant with Teflon® is recommended for use on plug threads.



18-4218D



18-4218
BRASS DRAIN COCK (1/4")
 Used with:
 Most O.E.M. Manifolds
18-3223-9 (Bulk Pack of 12)



18-8538
EXHAUST MANIFOLD MOUNTING KIT
 Barr and Indmar Ford Small Block V8 302-351cu.in.
 Used with:
 Manifold: 18-1998-1

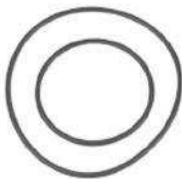

18-7512
EXHAUST ELBOW SEAL KIT
 Replaces: 7087-OR
 For use with 18-1944
 Exhaust Riser

PKG. OF 8



FREEZE PLUGS
18-5961 **18-5962**
18-5961-9 **18-5962-9**
 1 5/8" 1 3/4"
 BRONZE



18-4461
HOSE BARB
 3/4" - 14 NPT x 1" Hose
 Corrosion Resistant Brass Fitting



18-8215
HOSE BARB
 Fits: Chrysler V8



18-8216
HOSE BARB
 Fits: Chrysler-Small Block V8 (318-360ci), Big Block V8(383-440)

① Priced per Package ② Items ending in "D" are Display Packaged - Regular number is Non-Display