



## 2020 MASTER CATALOG

### OUTBOARD & STERNDRIVE PROPELLERS



Evinrude® | Johnson® | Force® | Chrysler® | U.S. Marine®  
Honda® | Mercury® | Mariner® | Nissan® | Tohatsu®  
Mercruiser® | Volvo Penta® | Yamaha® | Suzuki® | OMC®

**Evinrude/Johnson**

**15 HP (E-Tec)** 2011 & Newer; **20 HP** 1984-1997; **25 & 30 HP** 1984 & Newer; **25 & 30 HP (E-Tec)** 2009 & Newer; **35 HP** 1976 & Newer; 14 Tooth..... **118...E**  
**25 & 30 HP (4-Stroke)** 2004-2007; 10 Tooth Spline..... **121...E**  
**40 & 50 HP (4-Stroke)** 1999-2005; 13 Tooth Spline..... **115...D**  
**40-75 HP Small Gearcase** (3-3/8”) 1975-2005; 13 Tooth Spline.....**111...C**  
**40-75 HP Large Gearcase** (4-1/4”) 1968 & Newer; 13 Tooth Spline..... **206...B**  
**60 & 70 HP (4-Stroke)** 1998 & Newer; 13 Tooth Spline ..... **210...B**  
**85-140 HP** 1969 & Newer; 13 Tooth Spline ..... **206...B**  
**90 & 115 HP (4-Stroke)** 2002-2005; 15 Tooth Spline ..... **225...B**  
**140 HP (4-Stroke)** 2002-2005; 15 Tooth Spline ..... **226...B**  
**90-300 HP, Lg. Gearcase** 1976-1990; 15 Tooth Spline..... **201...A**  
**90-300 HP, Lg. Gearcase** 1991 & Newer; 15 Tooth Spline ..... **200...A**  
**200 & 225 HP (4-Stroke)** 2004-2005; 15 Tooth Spline..... **204...A**  
**150-300 HPE-TEC G2 Gearcase** 2014 & Newer; 15 Tooth Spline..... **228...A**

**Force**

**25 HP** 1995-1998; 10 Tooth Spline ..... **120...E**  
**40 & 50 HP** 1995-1998; **70 HP** 1991-1995; **75 HP** 1996-1998; 13 Tooth **114...D**  
**75-150 HP** 1995-1999; **85-150 HP (Dual Exhaust)** 1988-1994; 15 Tooth. **202...B**

**Honda**

**BF 25** 1994 & Newer; **BF 30** 1995 & Newer; 10 Tooth Spline ..... **119...E**  
**BF 35 & 45** 1991-1994; **BF 40/50/50A** 1995 & Newer;  
**BF 60**; 2010 & Newer; 13 Tooth Spline ..... **113...D**  
**BF 75 & BF 90** 1995-1998; 15 Tooth Spline ..... **202...B**  
**BFP 60** 2010 & Newer; **BF 75 & BF 90** 1999 & Newer; **BF 100** 2016 & Newer;  
**BF 115** 1998-2010; **BF 130** 1998-2004; 15 Tooth Spline..... **207...B**  
**BF 135-250 HP** 2002 & Newer; **BF 115D** 2011 & Newer; 15 Tooth ..... **207...A**

**Mercury/Mariner/Mercruiser**

**9.9, 15 HP (4-Stroke/Bigfoot/Sail)** 1999-2005; **18 HP (Mercury)** 1980-1985; **20 & 25 HP (Not 4-Stroke)** 1980-2005; 10 Tooth Spline..... **120...E**  
**25 & 30 HP (4-Stroke - Not Bigfoot)** 2006 & Newer; 10 Tooth Spline ... **122...E**  
**25 HP Bigfoot** 1999-2005; **30 HP (Sea Pro/Marathon)** 1994 & Newer;  
**30 HP (2- & 4-Stroke)** 1994-2005; **35 HP** 1984-1989; **40-50 HP** 1974-1976;  
**40/50/70 HP** 1977-1984; **45 HP** 1986-1989;  
**40 & 50 HP (2- & 4-Stroke, Not Bigfoot)** 1977 & Newer;  
**48 HP (Mariner)** All Years; **55 HP (Mercury/Sea Pro/Marathon)** 1995 & Newer;  
**60 HP (Not Bigfoot)** 1978 & Newer; **60 HP (Mariner)** 1976; **65 HP** 1972-1976;  
**70 HP** Thru 1983; **80 HP (Mariner)** 1977; 13 Tooth Spline ..... **114...D**  
**40-140 HP (Except 135 HP) V4 Gearcase** 1961 & Newer; 15 Tooth ..... **202...B**  
**135-300 HP** 1978 & Newer; 15 Tooth Spline ..... **202...A**  
**Mercruiser Alpha One & Bravo One** (< 400 HP); 15 Tooth Spline..... **202...A**

**Nissan/Tohatsu**

**25 & 30 HP** 1985-2001; **25 & 30 HP (4-Stroke)** 2002 & Newer..... **122...E**  
**35 HP (35B Only)** Thru 1984; **40 HP** 1984 & Newer;  
**50 HP (All Except 50C)** 1992 & Newer; 13 Tooth Spline ..... **116...D**  
**50 HP (50C Only)** 1987-1991; **55 HP** 1981-1988;  
**60A** 1986-1999; **70A & 70B** 1981-1995; 13 Tooth Spline ..... **112...C**  
**60-140 HP, 4-1/4” Gearcase** 1987 & Newer; 15 Tooth Spline..... **209...B**

**OMC/Cobra Sterndrives**

**Model 400 Cobra** 1978-1991; 13 Tooth Spline..... **206...B**  
**Model 800/Cobra/King Cobra** 1978-1990; 15 Tooth Spline ..... **201...A**  
**Model 800/Cobra/King Cobra** 1991-1994; 15 Tooth Spline ..... **200...A**  
**Cobra SX** 1994 & Newer; 19 Tooth Spline ..... **205...A**

**Suzuki**

**DT 20 & DT 25** 1985-1988; **DT 25C** 1989-2000; **DF 25A** 2014 & Newer;  
**DT 30** 1983-1997; **DT 30C** 1987-1997; **DF 30A** 2014 & Newer;  
**DF 25 & DF 30 (4-Stroke)** 2000-2007; 10 Tooth ..... **121...E**  
**DT 35C** 1987-1989; **DT 40** 1983-1998; **DF 40 & DF 50 (4-Stroke)** 1999-2010;  
**DF 40A & 50A** 2011 & Newer; **DT 50 & 50M** 1983-1984; **DT 55** 1985-1997;  
**DT 60** 1983-1984; **DF 60A** 2010 & Newer; **DT 65** 1985-1997; 13 Tooth **115...D**  
**DF 60 (4-Stroke)** 1998-2009; **DF 70 (4-Stroke)** 1998-2008;  
**DT 75/85/100/115/140** 1979-2001; 13 Tooth Spline ..... **210...B**  
**DF 50AV/60AV** 2015 & Newer; **DF 90** 2001-2008;  
**DF 100** 2009 & Newer; **DF 115** 2001-2012; 15 Tooth Spline ..... **225...B**  
**DF 115A & 140A** 2013 & Newer; **DF 140** 2002-2012; 15 Tooth Spline ... **226...B**  
**DF 70A/80A/90A** 2009 & Newer; 15 Tooth Spline ..... **227...B**  
**150-300 HP (Including 4-Stroke)** 1986 & Newer; 15 Tooth Spline..... **204...A**

**Yamaha**

**20 HP** 1996-1997; **25 HP** 1980 & Newer; **F25 (4-Stroke)** 1998-2006  
**F25 (4-Stroke)** 2010 & Newer; **30 HP** 1983-2002; 10 Tooth Spline..... **123...E**  
**T25** 2010 & Newer; **F30 (4-Stroke)** 2001-2005;  
**40 HP & 50 HP (Not T50)** 1984 & Newer; **F40 (4-Stroke)** 1999 & Newer;  
**48 HP** 1995-2000; **F50 (4-Stroke)** 1995 & Newer; **55 HP** 1976-1995;  
**60 HP** 1976-1991; **F60 (4-Stroke)** 1999 & Newer ..... **117...D**  
**50-100 HP (Including 4-Stroke)** 1984 & Newer; 15 Tooth Spline ..... **208...B**  
**115 & 130 HP** 1984 & Newer; **F115 (4-Stroke)** 2000 & Newer..... **203...B**  
**80-140 HP** 1977-1983; 15 Tooth Spline..... **202...B**  
**150-175 HP** 1978-1983; 15 Tooth Spline..... **202...A**  
**150-300 HP (Including 4-Stroke)** 1984 & Newer; **300 HP** 2004-07 ..... **203...A**  
**Sterndrives** 1989-1993; 15 Tooth Spline ..... **203...A**

**Volvo Penta**

**SX Sterndrives** 1994 & Newer; 19 Tooth Spline ..... **205...A**



**LIMITED WARRANTY**

Michigan Wheel warrants to the original consumer purchaser and original motor fitted, that for a period of one year from the date of purchase, the body of the Michigan Match®, Vortex®, Apollo® or Ballistic® propeller will be free of any defect in material or workmanship that results in blade or hub fracture or failure under normal pleasure boat usage. Michigan Wheel also warrants to the original consumer purchaser, under the same parameters of use described above, that the propeller bushing, including XHS®/XHS II® hub kit components, will be free from any defect in material or workmanship for a period of one year from the date of purchase. Proof of purchase required for all warranty claims.

Some surface discoloration of propellers and hardware is unavoidable, and will not be covered by this warranty. This warranty also does not cover normal wear, accidental damage, modification, improper installation, improper maintenance, or other circumstances that are not the direct result of a defect in the material or workmanship of the propeller.

The sole obligation of Michigan Wheel under this warranty is to repair or replace the propeller, in the sole discretion of Michigan Wheel, and at its expense. In order to make a replacement claim, please contact the Michigan Wheel Customer Service Department, at (616) 452-6941, for a “Return Materials Authorization” number (RMA#), and shipping instructions. The RMA# is to be indicated along with our given address on the label, and the shipping carton should include your return shipping address, your phone number, and a copy of your original purchase receipt. The warranty will not cover any expense of propeller removal, shipping, or reinstallation of the propeller.

The above warranty is Michigan Wheel’s sole warranty for the Michigan Match®, Vortex®, Apollo® or Ballistic® propellers as well as XHS®/XHS II® hub kits. Michigan Wheel expressly disclaims all other warranties, expressed or implied, including, without limitation, the warranties of merchantability and fitness for a particular purpose and excludes all liability for incidental or consequential damages, loss of use of the propeller, costs, and expenses.

Any actions arising out of this warranty and the sale of this product shall be governed by Michigan law and may only be brought, heard and decided in Kent County Circuit Court, in the State of Michigan, U.S.A., or in the United States District Court for the Western District of Michigan.

Michigan Wheel  
 1501 Buchanan Avenue S.W.  
 Grand Rapids, MI 49507  
 Phone: (616) 452-6941

**VORTEX® XHS® SERIES ALUMINUM PROPELLERS**

| PROP SERIES A |       | PROP SERIES B |             | PROP SERIES C |        | PROP SERIES D |       |        | PROP SERIES E        |       |        |                          |       |        |                  |       |        |
|---------------|-------|---------------|-------------|---------------|--------|---------------|-------|--------|----------------------|-------|--------|--------------------------|-------|--------|------------------|-------|--------|
| 3 & 4-Blade   |       |               | 3 & 4-Blade |               |        | 3 & 4-Blade   |       |        | Standard 3 & 4-Blade |       |        | Lg. Diameter 3 & 4-Blade |       |        | Standard 3-Blade |       |        |
| DIA x PITCH   | BLD # | P/N           | DIA x PITCH | BLD #         | P/N    | DIA x PITCH   | BLD # | P/N    | DIA x PITCH          | BLD # | P/N    | DIA x PITCH              | BLD # | P/N    | DIA x PITCH      | BLD # | P/N    |
| 16 x 13       | 3     | 992001        | 14 x 10     | 3             | 992109 | 11-1/2 x 8    | 4     | 992401 | 10-5/8 x 12          | 4     | 941212 | 11-1/2 x 8               | 4     | 992401 | 10-1/2 x 9       | 3     | 992501 |
| 15-1/4 x 15   | 3     | 992002        | 14 x 11     | 3             | 992111 | 11-1/2 x 9    | 4     | 992402 | 10-5/8 x 13          | 4     | 941213 | 11-1/2 x 9               | 4     | 992402 | 10-1/2 x 10      | 3     | 992502 |
| 16 x 16       | 3     | 931516        | 13-3/4 x 13 | 3             | 992112 | 11-1/2 x 10   | 4     | 992403 | 10-1/8 x 14          | 4     | 941214 | 11-1/2 x 10              | 4     | 992403 | 10-1/2 x 11      | 3     | 992503 |
| 15 x 17       | 3     | 992003        | 13-1/2 x 15 | 3             | 992113 | 11-3/4 x 13   | 3     | 992301 | 10-1/8 x 15          | 4     | 941215 | 12-1/4 x 9               | 3     | 992601 | 10-1/8 x 12      | 3     | 992504 |
| 14-1/2 x 19   | 3     | 992004        | 13-1/4 x 17 | 3             | 992114 | 11-3/4 x 15   | 3     | 992302 | 10-3/8 x 11          | 3     | 992404 | 11-3/4 x 10              | 3     | 992602 | 10-1/8 x 13      | 3     | 992505 |
| 14-1/4 x 21   | 3     | 992005        | 13 x 19     | 3             | 992115 | 11-3/4 x 17   | 3     | 992303 | 10-3/8 x 12          | 3     | 992405 | 11-5/8 x 11              | 3     | 992603 | 10-1/8 x 14      | 3     | 992506 |
| 14 x 23       | 3     | 992006        | 13 x 21     | 3             | 992116 | 12-1/2 x 13   | 3     | 992311 | 10-3/8 x 13          | 3     | 992406 | 11-3/8 x 12              | 3     | 992604 |                  |       |        |
| 15 x 16       | 4     | 992202        | 13-7/8 x 11 | 4             | 941411 | 12-1/4 x 15   | 3     | 992312 | 10-3/8 x 14          | 3     | 992407 | 11-1/8 x 13              | 3     | 992605 |                  |       |        |
| 14-1/2 x 18   | 4     | 992203        | 13-7/8 x 13 | 4             | 941413 |               |       |        | 10 x 15              | 3     | 992408 | 11-1/4 x 14              | 3     | 992606 |                  |       |        |
| 14 x 20       | 4     | 992204        | 13-3/8 x 15 | 4             | 941415 |               |       |        | 10 x 16              | 3     | 992409 |                          |       |        |                  |       |        |
|               |       |               | 13 x 17     | 4             | 941417 |               |       |        |                      |       |        |                          |       |        |                  |       |        |
|               |       |               | 12-1/2 x 19 | 4             | 941419 |               |       |        |                      |       |        |                          |       |        |                  |       |        |

**BALLISTIC® XHS® SERIES STAINLESS STEEL PROPELLERS**

| PROP SERIES A<br>V8/V6 APPLICATIONS |        |        | PROP SERIES B<br>V4 APPLICATIONS |       |        | PROP SERIES C         | PROP SERIES D | PROP SERIES E    |                  |                  |             |        |             |        |
|-------------------------------------|--------|--------|----------------------------------|-------|--------|-----------------------|---------------|------------------|------------------|------------------|-------------|--------|-------------|--------|
| Standard 3-Blade                    |        |        | Ballistic XL                     |       |        | Standard 3-Blade & XL |               | Standard 3-Blade | Standard 3-Blade | Standard 3-Blade |             |        |             |        |
| DIA x PITCH                         | RH P/N | LH P/N | DIA x PITCH                      | BLD # | RH P/N | DIA x PITCH           | BLD #         | RH P/N           | DIA x PITCH      | RH P/N           | DIA x PITCH | RH P/N | DIA x PITCH | RH P/N |
| 14-7/8 x 15                         | 933515 |        | 14-3/4 x 22                      | 3     | 953522 | 13-5/8 x 15           | Std. 3-Blade  | 933415           | 12-3/8 x 15      | 933315           | 10-1/8 x 13 | 933213 | 10-1/8 x 13 | 933013 |
| 14-3/4 x 17                         | 933517 | 937517 | 14-3/4 x 24                      | 3     | 953524 | 13-1/2 x 17           | Std. 3-Blade  | 933417           | 12 x 17          | 933317           | 10-1/8 x 15 | 933215 | 10-1/8 x 15 | 933015 |
| 14-1/2 x 19                         | 933519 | 937519 | 14-3/4 x 26                      | 3     | 953526 | 13-3/8 x 19           | Std. 3-Blade  | 933419           |                  |                  |             |        |             |        |
| 14-3/8 x 21                         | 933521 | 937521 |                                  |       |        | 13-1/8 x 21           | Std. 3-Blade  | 933421           |                  |                  |             |        |             |        |
| 14-1/4 x 23                         | 933523 | 937523 | 14-1/8 x 23                      | 4     | 963523 |                       |               |                  |                  |                  |             |        |             |        |
| 14-1/4 x 25                         | 933525 |        | 14-1/8 x 25                      | 4     | 963525 | 13-1/2 x 22           | 3-Blade XL    | 953422           |                  |                  |             |        |             |        |
|                                     |        |        | 14-1/8 x 27                      | 4     | 963527 | 13-1/2 x 24           | 3-Blade XL    | 953424           |                  |                  |             |        |             |        |

\* For Apollo XHS Series Stainless Steel Propeller offering, please refer to 2019 XHS Application Chart, or applicable engine category within this catalog.

**Need Your Propeller Repaired?**

Congratulations, you have chosen a top quality propeller. Should it become damaged during use, you want a qualified trained technician to repair it. Contact the **National Marine Propeller Association (NMPA)** at 954-880-3588 (F: 954-239-2600), or visit them on the web (www.nmpa.net) for a certified propeller repair shop near you.

Warranty claims are to be addressed directly to **Michigan Wheel** per instructions on this warranty statement and not to the **NMPA**.

# Contents:

---

|                                  |           |
|----------------------------------|-----------|
| Propeller Basics .....           | A3 - A6   |
| Choosing the Correct Pitch ..... | A7        |
| Basic Troubleshooting .....      | A8        |
| Engine RPM Chart.....            | A10 - A11 |
| Michigan Propellers.....         | A12 - A14 |

## OUTBOARD PROPELLERS



|   |         |
|---|---------|
| How to Use the Application Guide .....                                | A15     |
| Evinrude <sup>®</sup> , Johnson <sup>®</sup> Outboards.....           | 2 - 11  |
| Force <sup>®</sup> , Chrysler, U.S. Marine Outboards.....             | 12 - 15 |
| Honda <sup>®</sup> Outboards .....                                    | 16 - 19 |
| Mercury <sup>®</sup> , Mariner <sup>®</sup> , Sea Ray Outboards ..... | 20 - 26 |
| Nissan <sup>®</sup> / Tohatsu <sup>®</sup> Outboards.....             | 28 - 32 |
| Suzuki <sup>®</sup> Outboards.....                                    | 33 - 37 |
| Yamaha <sup>®</sup> Outboards .....                                   | 38 - 42 |
| Parsun <sup>®</sup> / Selva <sup>®</sup> Outboards .....              | 43 - 46 |

## STERNDRIVE PROPELLERS



|   |         |
|---|---------|
| Mercruiser <sup>®</sup> Sterndrives .....                         | 47 - 48 |
| OMC <sup>®</sup> Sterndrives .....                                | 49 - 50 |
| Volvo Penta <sup>®</sup> Sterndrives .....                        | 51      |
| Yamaha <sup>®</sup> Sterndrives.....                              | 52      |
| XHS <sup>®</sup> / XHS II <sup>®</sup> Attachment Hardware .....  | 54      |
| XHS <sup>®</sup> / XHS II <sup>®</sup> Propeller Accessories..... | 55 - 56 |

## SKI & TOWBOAT PROPELLERS



|  |     |
|--|-----|
| Dyna-Jet <sup>®</sup> 3-Blade Ski Propeller..... | A14 |
| Extreme 4-Blade Ski/Towboat Propeller .....      | A14 |

## PROPELLER CROSS REFERENCE



|   |          |
|---|----------|
| Michigan Wheel Alpha-Numeric Cross Reference.....                       | B2 - B4  |
| Michigan Wheel - Turning Point <sup>®</sup> Cross Reference .....       | B4       |
| Michigan Wheel to Solas <sup>®</sup> Cross Reference .....              | B5       |
| Michigan Wheel to Quicksilver <sup>®</sup> Cross Reference .....        | B6       |
| XHS <sup>®</sup> / XHS II <sup>®</sup> Hub System Cross Reference ..... | B7       |
| OEM Cross Reference .....   | B8 - B31 |
| Michigan Wheel Warranty .....   | B32      |

# PROPELLER BASICS

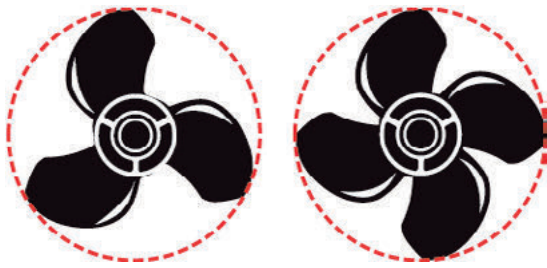

## Diameter

Diameter is two times the distance from the center of the hub to the tip of the blade. It also can be looked at as the distance across the circle that the propeller would make when rotating. It is the first number listed when describing a propeller.

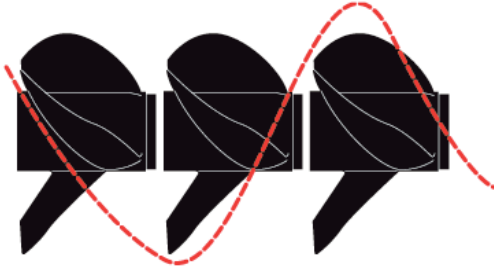

## Pitch

Pitch is defined as the theoretical forward movement of a propeller during one revolution - assuming there is no “slippage” between the propeller blade and the water. For most boats, there is slippage and therefore the distance advanced is less than the design pitch. The amount of slippage varies from boat to boat. Pitch is the second number listed in the propeller description.

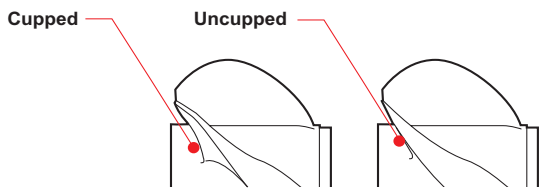

## Cupping

Many of today’s propellers incorporate a cup at the trailing edge of the propeller blade. This curved lip on the propeller allows it to get a better bite on the water. This results in reduced ventilation, slipping, and allows for better hole shot in many cases. A cupped propeller also works very well where the motor can be trimmed so that the propeller is near the surface of the water. The cup will typically result in higher top end speed on one of these applications.

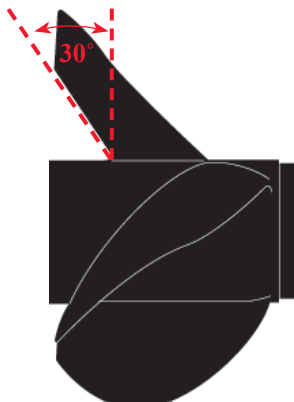

## Rake

Rake is the degree that the blades slant forward or backwards in relation to the hub. Rake can affect the flow of water through the propeller, and has implications with respect to boat performance.

**Aft Rake** helps to trim the bow of the boat upwards, which often results in less wetted surface area and therefore higher top end speed. Aft Rake propellers also typically provide better “bite” on ventilating-type applications.

**Forward, or Negative Rake**, helps hold the bow of the boat down. This is more common in workboat type applications.

## Ventilation

Ventilation is a situation where surface air or exhaust gases are drawn into the propeller blades. When this situation occurs, boat speed is lost and engine RPM climbs rapidly. This can result from excessively tight cornering, a motor that is mounted very high on the transom, or by over-trimming the engine.

## Cavitation

Cavitation, which is often confused with ventilation, is a phenomena of water vaporizing or “boiling” due to the extreme reduction of pressure on the back of the propeller blade. Many propellers partially cavitate during normal operation, but excessive cavitation can result in physical damage to the propeller’s blade surface due to the collapse of microscopic bubbles on the blade.

There may be numerous causes of cavitation such as incorrect matching of propeller style to application, incorrect pitch, physical damage to the blade edges, etc.

Be advised disturbances in the water flow forward of the propeller can result in blade damage, which appears to be blade cavitation, but is actually due to non-favorable water flow into the propeller.

# PROPELLER BASICS

Finding the right match between the propeller, engine type and boat size will optimize the following performance factors:

- Increased Top End Speed
- Faster Planing Speed (Hole Shot)
- Improved Low End Punch
- Load Carrying Capability

If you want to modify your boat's performance, consider the following before making your selection:

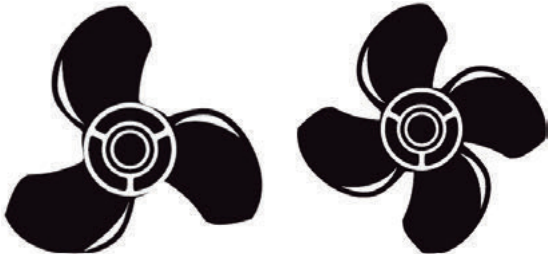

## 3-Blade Propeller vs. 4-Blade Propeller

We recommend 3-Blade propellers for recreational boats with 3, 4, and 6 cylinder outboards and I/O engines. These propellers provide good hole shot and top-speed performance.

We recommend 4-Blade propellers for practical, all-around boat performance. These propellers enhance handling, hole shot, load-carrying performance, and fuel efficiency.



## Aluminum vs. Stainless Steel

Most pleasure boats are factory equipped with aluminum propellers. Aluminum propellers are relatively inexpensive, easy to repair, and under normal conditions can last for many years.

Stainless steel is more expensive, but much stronger and durable than aluminum. If you are looking for better performance than can be provided by your aluminum propeller, such as ultimate top speed or better acceleration, a stainless steel propeller may be required.



## Advantage of a Left Hand Propeller

Two propellers spinning in the same direction on twin engine boats will create steering torque. In other words, two right-hand propellers pull the stern hard to the right and the bow to the left.

Two opposite-direction (counter-rotating) propellers on twin engines eliminate this steering torque because the left-hand propeller balances out the right-hand propeller. This results in better straight-line tracking and helm control at high speed.



Theoretical   
Actual 

## Affect of Slip on Performance

Slip is the difference between actual and theoretical travel of the propeller blades through water. A properly matched propeller will actually move forward about 80 to 90 percent of the theoretical pitch.

# PROPELLER BASICS

What is the difference between thru-hub exhaust, over-hub exhaust, and non thru-hub exhaust?

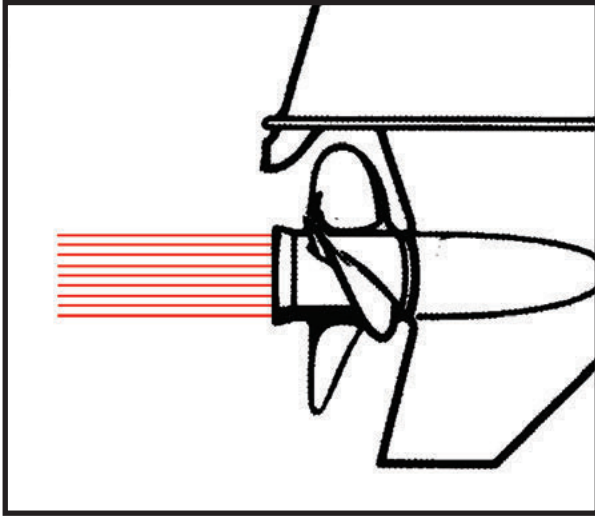

**THRU-HUB EXHAUST**

Thru-hub exhaust propellers consist of a round barrel to which the blades are attached. The exhaust passes through the barrel and out the back, without making contact with the propeller blades. This provides a good, clean water flow to the blades, usually resulting in good acceleration and hole shot.

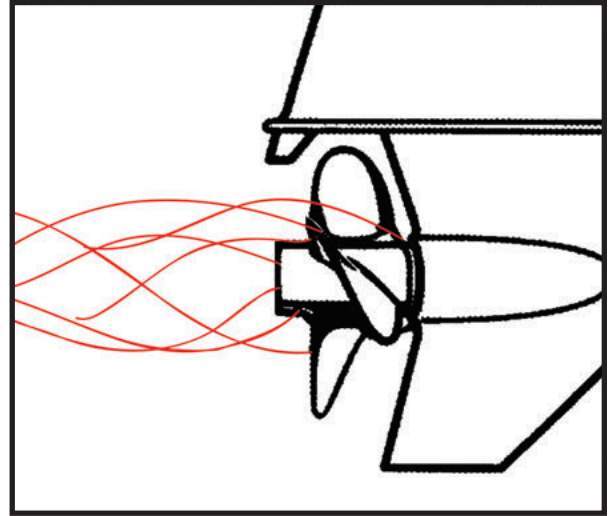

**OVER-HUB EXHAUST**

Over-hub exhaust propellers have the blades attached directly to the smaller tube that fits over the propeller shaft, eliminating the larger exhaust tube. These types of propellers are often used for attaining maximum top speeds. (On some boats, the hole shot can often suffer due to the extreme exhaust flooding that occurs around the propeller blades during acceleration.)

**THRU-HUB EXHAUST** and **OVER-HUB EXHAUST** propellers are used on boats where the exhaust passes out through the rear of the “torpedo” on the lower unit, around the propeller shaft. Most outboards utilize this type of exhaust.

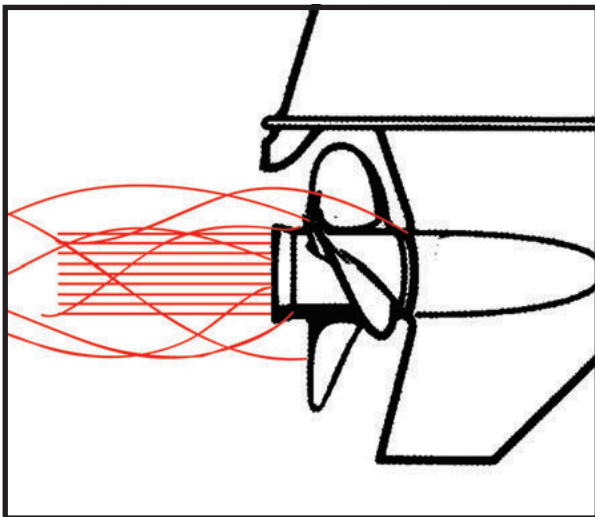

**OVER/THRU-HUB EXHAUST**

Over/Thru-hub exhaust propellers are a combination of thru-hub and over-hub exhaust propellers. This allows some exhaust to escape at lower RPM, providing a controlled amount of exhaust flooding. These types of propellers will allow the propeller to be slightly easier to turn during initial acceleration, allowing for better hole shot on some engine/boat combinations.

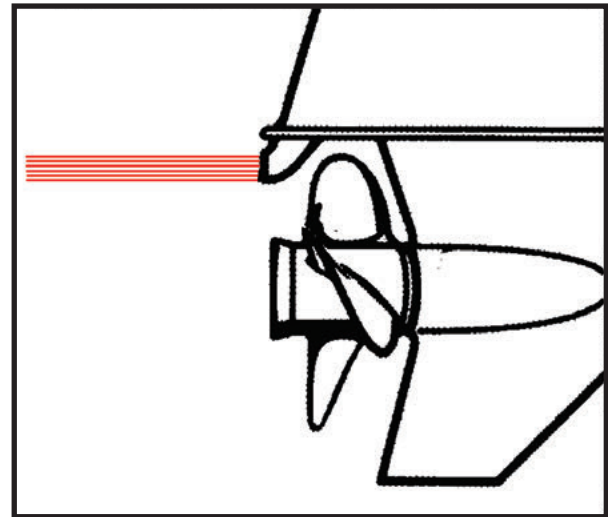

**NON THRU-HUB EXHAUST**

Non thru-hub exhaust propellers are used for inboards using shaft driven propellers, sterndrives using through hull exhaust, and on some outboards that don't route the exhaust through the lower unit torpedo.

# CHOOSING THE CORRECT PITCH

For safety and efficient performance, it is critical that your engine operates within the RPM range recommended by the manufacturer. Matching the right prop for the load is the most significant factor when choosing a new propeller.

## 1) Determine Manufacturer's Recommended RPM

Find the manufacturer's recommended RPM range in the owner's manual or ask your dealer. A reference chart showing common engine applications is shown on Pages A6-A7 of this catalog.

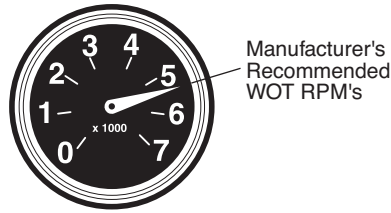

## 2) Test for Maximum RPM

Using the existing propeller or a new propeller, make test runs to determine the maximum RPM and boat speed. Vary the trim angle for optimum performance.



## 3a) If RPM are Higher Than Recommended

If the actual WOT RPM are *above* the recommended RPM range, install the next larger pitch propeller to *decrease* your WOT RPM. Re-test the WOT RPM.

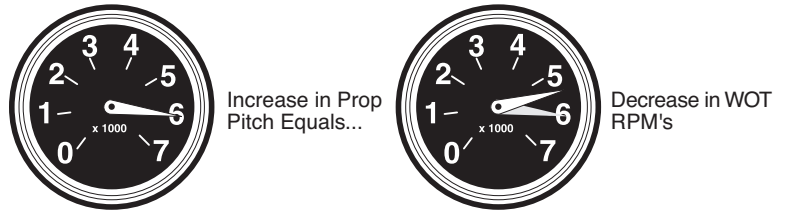

## 3b) If RPM are Lower Than Recommended

If the actual WOT RPM range is *below* the recommended range, install the next smaller pitch propeller to *increase* your WOT RPM. Re-test the WOT RPM.

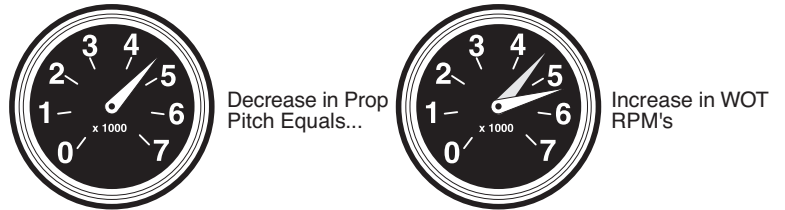

*When you combine all these factors, you have the information you need to select the correct propeller for maximum performance, safety, and fuel efficiency.*

## Effect of Propeller Pitch on RPM

A pitch change can increase or decrease the RPM and bring RPM into the recommended range. A 2" increase in pitch (for example, from 21" to 23") typically results in a decrease of approximately 300-400 RPM.

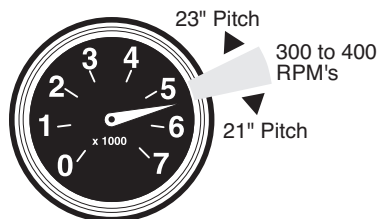

# BASIC TROUBLESHOOTING

## • When installing an XHS / XHS II Hub System:

1. Confirm that the propeller is meant for use with your engine application (Figure 4).
2. Gearcase adapter rings are required for ALL VORTEX® “E” Series propellers. Gearcase adapter rings are supplied with every V4 VORTEX® and APOLLO® propeller, and may or may not be required (Figure 1 - 3).

| Boat Description/Length<br>CR, HB | VORTEX<br>MICHIGAN |      |       |       |            | APOLLO<br>MICHIGAN |       |      |       |       | Drop-In Hub<br>Use XHS II®<br>Hub Kit<br><b>209</b><br><i>Refer to page 11-52<br/>for Details on Hub Kit<br/>Component.</i> |            |        |
|-----------------------------------|--------------------|------|-------|-------|------------|--------------------|-------|------|-------|-------|---|------------|--------|
|                                   | Dis.               | Rot. | Pitch | Blk # | OEM Part # | Part #             | Dis.  | Rot. | Pitch | Blk # |   | OEM Part # | Part # |
| 22'-25'-AL, SK                    | 13-34              | R    | 13    | 3     | 2N48645271 | 992112             |       |      |       |       |   |            |        |
| 19'-22'-AL, SK                    | 13-12              | R    | 15    | 3     | 2N48645221 | 992113             | 13-38 | R    | 15    | 3     | PT7015P13   | 993143     |        |
| 18'-21'-AL, SK                    | 13-14              | R    | 17    | 3     | 2N48645261 | 992114             | 13-14 | R    | 17    | 3     | NM58961070  | 993144     |        |
| 18'-21'-AL, SK                    |                    |      |       |       |            |                    | 13-14 | L    | 17    | 3     |   | 993143     |        |
| 17'-20'-AL, SK                    | 13                 | R    | 19    | 3     | 2N48645111 | 992115             | 13-18 | R    | 19    | 3     |   | 993145     |        |
| 17'-20'-AL, SK                    |                    |      |       |       |            |                    | 13-18 | L    | 19    | 3     |   | 993145     |        |
| 15'-18'-AL, SK                    | 13                 | R    | 21    | 3     | 2N48645151 | 992116             | 13    | R    | 21    | 3     |   | 993146     |        |
| 15'-18'-AL, SK                    |                    |      |       |       |            |                    | 13    | L    | 21    | 3     |   | 993146     |        |

| 25-30 HORSEPOWER (4-STROKE) • 3" GEARCASE<br>Thru Hub Exhaust & 10 Tooth Spline   |                    | 2004-2007 |       | 30 HP 4-Stroke |            | 2004-2007  |        |                         |                    |  |  |  |  |  |      |      |       |       |            |        |               |        |   |   |   |  |        |              |        |   |    |   |  |        |              |        |   |    |   |  |        |              |        |   |    |   |  |        |              |        |   |    |   |  |        |                |        |   |    |   |  |        |
|---|--------------------|-----------|-------|----------------|------------|--|--------|-------------------------|--------------------|--|--|--|--|--|------|------|-------|-------|------------|--------|---------------|--------|---|---|---|--|--------|--------------|--------|---|----|---|--|--------|--------------|--------|---|----|---|--|--------|--------------|--------|---|----|---|--|--------|--------------|--------|---|----|---|--|--------|----------------|--------|---|----|---|--|--------|
| <table border="1"> <thead> <tr> <th rowspan="2">Boat Description/Length</th> <th colspan="5">VORTEX<br/>MICHIGAN</th> <th rowspan="2">Drop-In Hub<br/>Use XHS®<br/>Hub Kit<br/><b>121</b><br/><i>Refer to page 11-52<br/>for Details on Hub Kit<br/>Component.</i></th> </tr> <tr> <th>Dis.</th> <th>Rot.</th> <th>Pitch</th> <th>Blk #</th> <th>OEM Part #</th> <th>Part #</th> </tr> </thead> <tbody> <tr> <td>20' &amp; Up - AL</td> <td>10-1/2</td> <td>R</td> <td>9</td> <td>3</td> <td></td> <td>992501</td> </tr> <tr> <td>17'-20' - AL</td> <td>10-1/2</td> <td>R</td> <td>10</td> <td>3</td> <td></td> <td>992502</td> </tr> <tr> <td>17'-20' - AL</td> <td>10-1/2</td> <td>R</td> <td>11</td> <td>3</td> <td></td> <td>992503</td> </tr> <tr> <td>15'-18' - AL</td> <td>10-1/8</td> <td>R</td> <td>12</td> <td>3</td> <td></td> <td>992504</td> </tr> <tr> <td>13'-15' - AL</td> <td>10-1/8</td> <td>R</td> <td>13</td> <td>3</td> <td></td> <td>992505</td> </tr> <tr> <td>Up to 15' - LL</td> <td>10-1/8</td> <td>R</td> <td>14</td> <td>3</td> <td></td> <td>992506</td> </tr> </tbody> </table> |                    |           |       |                |            |  |        | Boat Description/Length | VORTEX<br>MICHIGAN |  |  |  |  | Drop-In Hub<br>Use XHS®<br>Hub Kit<br><b>121</b><br><i>Refer to page 11-52<br/>for Details on Hub Kit<br/>Component.</i> | Dis. | Rot. | Pitch | Blk # | OEM Part # | Part # | 20' & Up - AL | 10-1/2 | R | 9 | 3 |  | 992501 | 17'-20' - AL | 10-1/2 | R | 10 | 3 |  | 992502 | 17'-20' - AL | 10-1/2 | R | 11 | 3 |  | 992503 | 15'-18' - AL | 10-1/8 | R | 12 | 3 |  | 992504 | 13'-15' - AL | 10-1/8 | R | 13 | 3 |  | 992505 | Up to 15' - LL | 10-1/8 | R | 14 | 3 |  | 992506 |
| Boat Description/Length   | VORTEX<br>MICHIGAN |           |       |                |            | Drop-In Hub<br>Use XHS®<br>Hub Kit<br><b>121</b><br><i>Refer to page 11-52<br/>for Details on Hub Kit<br/>Component.</i> |        |                         |                    |  |  |  |  |  |      |      |       |       |            |        |               |        |   |   |   |  |        |              |        |   |    |   |  |        |              |        |   |    |   |  |        |              |        |   |    |   |  |        |              |        |   |    |   |  |        |                |        |   |    |   |  |        |
|   | Dis.               | Rot.      | Pitch | Blk #          | OEM Part # |  | Part # |                         |                    |  |  |  |  |  |      |      |       |       |            |        |               |        |   |   |   |  |        |              |        |   |    |   |  |        |              |        |   |    |   |  |        |              |        |   |    |   |  |        |              |        |   |    |   |  |        |                |        |   |    |   |  |        |
| 20' & Up - AL   | 10-1/2             | R         | 9     | 3              |            | 992501   |        |                         |                    |  |  |  |  |  |      |      |       |       |            |        |               |        |   |   |   |  |        |              |        |   |    |   |  |        |              |        |   |    |   |  |        |              |        |   |    |   |  |        |              |        |   |    |   |  |        |                |        |   |    |   |  |        |
| 17'-20' - AL  | 10-1/2             | R         | 10    | 3              |            | 992502   |        |                         |                    |  |  |  |  |  |      |      |       |       |            |        |               |        |   |   |   |  |        |              |        |   |    |   |  |        |              |        |   |    |   |  |        |              |        |   |    |   |  |        |              |        |   |    |   |  |        |                |        |   |    |   |  |        |
| 17'-20' - AL  | 10-1/2             | R         | 11    | 3              |            | 992503   |        |                         |                    |  |  |  |  |  |      |      |       |       |            |        |               |        |   |   |   |  |        |              |        |   |    |   |  |        |              |        |   |    |   |  |        |              |        |   |    |   |  |        |              |        |   |    |   |  |        |                |        |   |    |   |  |        |
| 15'-18' - AL  | 10-1/8             | R         | 12    | 3              |            | 992504   |        |                         |                    |  |  |  |  |  |      |      |       |       |            |        |               |        |   |   |   |  |        |              |        |   |    |   |  |        |              |        |   |    |   |  |        |              |        |   |    |   |  |        |              |        |   |    |   |  |        |                |        |   |    |   |  |        |
| 13'-15' - AL  | 10-1/8             | R         | 13    | 3              |            | 992505   |        |                         |                    |  |  |  |  |  |      |      |       |       |            |        |               |        |   |   |   |  |        |              |        |   |    |   |  |        |              |        |   |    |   |  |        |              |        |   |    |   |  |        |              |        |   |    |   |  |        |                |        |   |    |   |  |        |
| Up to 15' - LL  | 10-1/8             | R         | 14    | 3              |            | 992506   |        |                         |                    |  |  |  |  |  |      |      |       |       |            |        |               |        |   |   |   |  |        |              |        |   |    |   |  |        |              |        |   |    |   |  |        |              |        |   |    |   |  |        |              |        |   |    |   |  |        |                |        |   |    |   |  |        |

Fig. 1 (Above) All Vortex “E” Series Propellers are shipped with a set of (3) gearcase adapter rings, and requires use of appropriate ring - indicated on the tabs.

Fig. 2 All Vortex and Apollo “B” Series (V4) Propellers are shipped with (1) gearcase adapter ring. Some engines require use of this gearcase adapter ring (Top Left), others do not (Bottom Left).



Fig. 3 Failure to install gearcase adapter ring leaves gap that causes excessive ventilation, poor performance.

3. Confirm the correct XHS® / XHS II® Hub Kit has been selected for your engine.
4. All OEM attachment hardware must be removed prior to installation of XHS® / XHS II® Hub Kits. The shaft taper must be visible (Figure 5). If the propeller shaft taper is not visible, the OEM forward thrust washer is likely still installed (Figure 6).
5. The forward thrust washer is tapered and will nest with the taper on the propeller shaft with little effort (Figure 7).
6. Each additional XHS® / XHS II® Hub Kit component is designed to be installed in a specific order. Refer to XHS® Installation Instructions (Form 990445) for correct order (Figure 8).
7. Verify all hardware components packaged with your XHS® / XHS II® Hub Kit have been used. Component part numbers can be found on Pg. 56 & 57.
8. Ensure your propeller nut is torqued to the manufacturer’s recommended value identified in your engine owner’s manual.



Fig. 4 Vortex “C” Series (3-3/8”) Propeller installed on a V4 (4-1/4”) gearcase. Results in poor performance and excessive ventilation. Vortex “B” Series (4-1/4”) Propeller should be used.



Fig. 5 Propeller shaft taper is visible, indicating OEM forward thrust washer has been removed. XHS Hub Kit forward thrust washer ready to be installed.



Fig. 6 OEM forward thrust washer was not removed. XHS Hub Kit and Michigan Wheel propeller will not fit properly.



Fig. 7 The forward thrust washer is tapered and will nest with the taper on the propeller shaft. When properly installed, the part number will be visible.

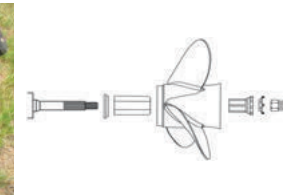

Fig. 8 The forward thrust washer MUST be installed first. Failure to install a forward thrust washer will cause gearcase damage and potential injury.

## • Other Common Installation Mistakes:



Over time, the forward thrust washer may appear as part of the propeller shaft. It is still necessary to remove the thrust washer when installing an XHS propeller.



The gearcase adapter ring will snap into place, and lay flush with the propeller. If there is a gap, it is not properly installed.



Aft drive adapter incorrectly installed. The propeller will fall off the propeller shaft if run with this incorrect installation.



The shaft taper takes forward thrust from the thrust washer. Without a forward thrust washer, the gearcase takes the forward thrust as the propeller will continue to move forward on the shaft, causing severe damage to the gearcase.



... Seriously?

## • When installing a rubber hub propeller:

1. Determine if this is a “drop-in hub” to Michigan Match® installation. If yes, follow the replacement instructions on Page. 27.
2. If this is an OEM to Michigan Match® installation, make sure all hardware components are available. Confirm that the forward thrust washer is not stuck in the old propeller.
3. Michigan Match® is an OEM-equivalent propeller. If the correct OEM propeller and attachment hardware was being used, the Michigan Match® equivalent will fit without issue.



# WATER LUBRICATED BEARINGS

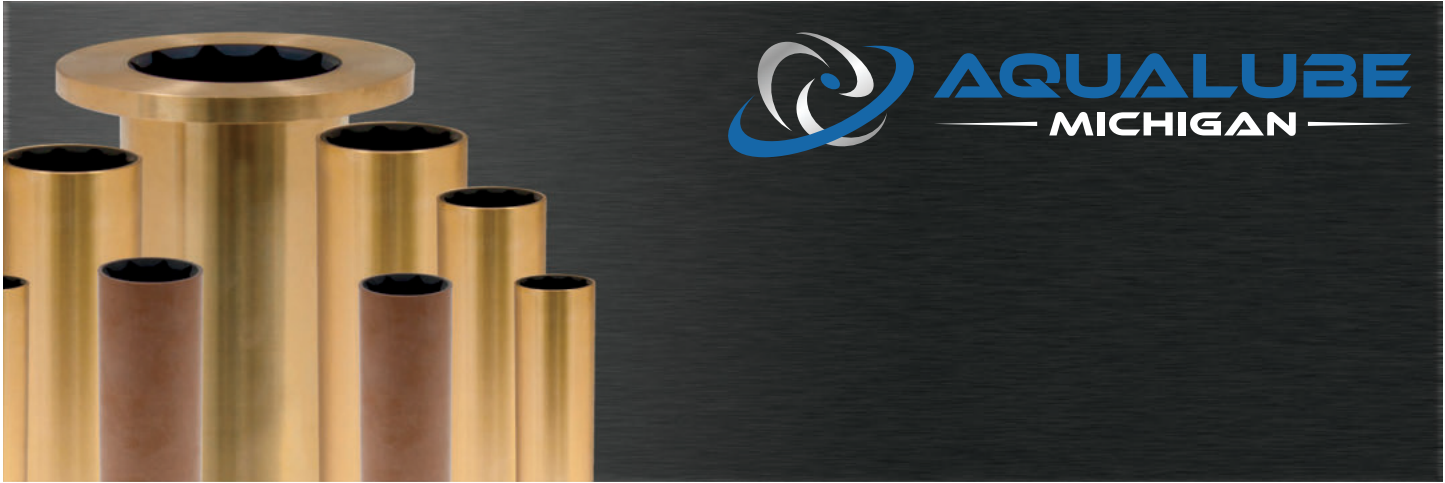

AQUALUBE®



Aqualube bearings are designed for marine and industrial applications. The bearings feature a specially formulated rubber and are molded into various shell materials. The rubber is an extremely tough, chemical and oil resistant nitrile which offers outstanding resistance to abrasion and wear even in the most adverse conditions.

| Part Number | Material | I.D.  | O.D.  | Length | Part Number | Material | I.D.  | O.D.    | Length |
|-------------|----------|-------|-------|--------|-------------|----------|-------|---------|--------|
| 907501      | Brass    | 3/4   | 1-1/4 | 3      | 917501      | Brass    | 1-3/4 | 2-3/8   | 7      |
| 908751      | Brass    | 7/8   | 1-1/4 | 3-1/2  | 917503      | Brass    | 1-3/4 | 2-1/2   | 7      |
| 908752      | Brass    | 7/8   | 1-3/8 | 3-1/2  | 917502      | Brass    | 1-3/4 | 2-5/8   | 7      |
| 908753      | Brass    | 7/8   | 1-1/2 | 3-1/2  | 918251      | Brass    | 1-7/8 | 2-5/8   | 7-1/2  |
| 910001      | Brass    | 1     | 1-1/4 | 4      | 918252      | Brass    | 1-7/8 | 2-15/16 | 7-1/2  |
| 910002      | Brass    | 1     | 1-3/8 | 4      | 920001      | Brass    | 2     | 2-5/8   | 8      |
| 910003      | Brass    | 1     | 1-1/2 | 4      | 920002      | Brass    | 2     | 2-3/4   | 8      |
| 910004      | Brass    | 1     | 1-5/8 | 4      | 920003      | Brass    | 2     | 3       | 8      |
| 910005      | Brass    | 1     | 2     | 4      | 921252      | Brass    | 2-1/8 | 2-15/16 | 8-1/2  |
| 911251      | Brass    | 1-1/8 | 1-1/2 | 4-1/2  | 921254      | Brass    | 2-1/8 | 3-1/8   | 8-1/2  |
| 911252      | Brass    | 1-1/8 | 1-5/8 | 4-1/2  | 922501      | Brass    | 2-1/4 | 2-15/16 | 9      |
| 911253      | Brass    | 1-1/8 | 1-3/4 | 4-1/2  | 922502      | Brass    | 2-1/4 | 3       | 9      |
| 911254      | Brass    | 1-1/8 | 2     | 4-1/2  | 922503      | Brass    | 2-1/4 | 3-1/8   | 9      |
| 912501      | Brass    | 1-1/4 | 1-1/2 | 5      | 922505      | Brass    | 2-1/4 | 3-3/8   | 9      |
| 912503      | Brass    | 1-1/4 | 1-3/4 | 5      | 923751      | Brass    | 2-3/8 | 3-3/8   | 9-1/2  |
| 912505      | Brass    | 1-1/4 | 2     | 5      | 925002      | Brass    | 2-1/2 | 3-1/8   | 10     |
| 912507      | Brass    | 1-1/4 | 2-1/8 | 5      | 925003      | Brass    | 2-1/2 | 3-1/4   | 10     |
| 913751      | Brass    | 1-3/8 | 1-7/8 | 5-1/2  | 925004      | Brass    | 2-1/2 | 3-3/8   | 10     |
| 913752      | Brass    | 1-3/8 | 2     | 5-1/2  | 925005      | Brass    | 2-1/2 | 3-1/2   | 10     |
| 913754      | Brass    | 1-3/8 | 2-1/8 | 5-1/2  | 926252      | Brass    | 2-5/8 | 3-3/8   | 10-1/2 |
| 915001      | Brass    | 1-1/2 | 2     | 6      | 927501      | Brass    | 2-3/4 | 3-3/8   | 11     |
| 915004      | Brass    | 1-1/2 | 2-3/8 | 6      | 927502      | Brass    | 2-3/4 | 3-1/2   | 11     |
| 916251      | Brass    | 1-5/8 | 2-1/8 | 6-1/2  | 927503      | Brass    | 2-3/4 | 3-3/4   | 11     |
| 916255      | Brass    | 1-5/8 | 2-5/8 | 6-1/2  | 927701      | Brass    | 2-7/8 | 3-3/4   | 11-1/2 |

Aqualube bearings available in sizes up to 30" in length, in brass and phenolic (non-metallic) material. Metric dimensions also available. Contact Michigan Wheel Europe Headquarters for Aqualube bearing part numbers and stock.





# MICHIGAN PROPELLERS



## APOLLO® STANDARD 3-BLADE

Apollo® propellers are highly polished, ultimate performance, stainless steel wheels. Apollo® is designed to use Michigan Wheel's XHS® / XHS II® hub system, and is interchangeable with Mercury's Flo-Torq® II hub system.

- **Ø- Ø HP (12" - 15" pitch; RH rotation)**
- **V4 Outboard (15" - 21" pitch; RH & LH rotation)**
- **V6 V8 OBSD (15" - 23" pitch; RH & LH rotation)**

**Recommend d Boat Applications:** *Inflatables, Aluminum Consoles, Bass Boats, Flats Boats, Sport Boat Singles, Sport Boat Duals*

## APOLLO® LARGE DIAMETER 3-BLADE

The Apollo® 3-Blade Large Diameter propeller is great for heavier applications that require increased blade area. Common to the entire Apollo® line, the Apollo® Large Diameter 3-Blade features CAD designed high performance blade geometry.

- **V6 V8 OBSD (17" - 23" pitch; RH & LH rotation)**

**Recommend d Boat Applications:** *Bay Boats, Offshore Singles & Duals, Sport Boat Singles & Duals, Pontoons, Family Cruisers, Workboats, Houseboats*

## APOLLO® 4-BLADE

The Apollo® 4-Blade propeller is designed to improve hole shot on heavier loads. This propeller is ideal for pulling/towing in water sports. High performance blade geometry, high luster finish, utilization of XHS® / XHS II® hub kit, and interchangeability with Mercury's Flo-Torq® II hub system makes the Apollo® 4-Blade the perfect propeller for a wide range of boats.

- **V6 V8 OBSD (18" - 22" pitch; RH & LH rotation)**

**Recommend d Boat Applications:** *Aluminum Consoles, Bay Boats, Walleye Boats, Offshore Singles & Duals, Sportboat Singles & Duals, Skiboats*



## BALLISTIC®

High performance stainless steel propellers with the proven Power Tip for peak efficiency, Ballistic is designed to use Michigan Wheel's XHS® / XHS II® hub system. The blade tip and cup combine to improve bite and reduce power losses caused by cavitation. Highly cambered blade sections provide for higher speed and better bow lift.

- **Interchangeable with Mercury's Flo-Torq® II hub system**
- **Tapered leading edges minimize drag**
- **Performance characteristics of racing style propellers**
- **Maintains optimum blade strength and thickness**
- **Ideal for the performance-minded boater**
- **Available in stainless steel, RH & LH rotation**

**Recommend d Boat Applications:** *Bass Boats, Bay Boats, Flats Boats, Pontoons, Sport Boat Single, Sport Boat Dual, Skiboats*

# MICHIGAN PROPELLERS

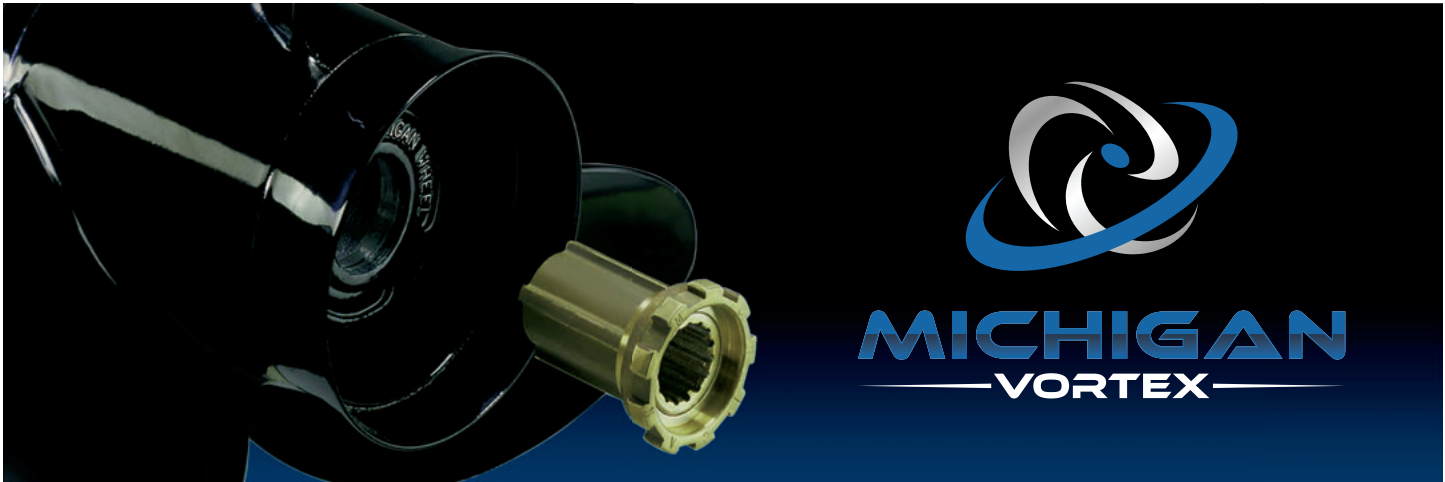

## VORTEX® 3-BLADE

Michigan Wheel's high performance aluminum propeller utilizing XHS® / XHS II® Xchangeable Hub System. Featuring high performance blade geometry, precision balanced blades, high gloss powder coat and interchangeability with the Mercury Flo-Torq® II system, the Vortex® XHS® / XHS II® is a great choice for a replacement or spare propeller for boaters.

- **20-0 HP (9" - 17" pitch; RH rotation)**
- **V4 Outboard (10" - 21" pitch; RH rotation)**
- **V6 V8 OBSD (15" - 23" pitch; RH rotation)**

*Recommended Boat Applications: Inflatables, Aluminum Consoles, Walleye Boats, Offshore Singles, Pontoons, Skiboats, Family Cruisers*

## VORTEX® 4-BLADE

For quicker planing, improved handling and acceleration. Vortex® 4-Blade aluminum propellers are a great alternative to a comparable 3-Blade propeller, offering enhanced performance when towing water skiers, tubers, knee and wakeboarders.

- **20-0 HP (8" - 10" pitch; RH rotation)**
- **V4 Outboard (11" - 19" pitch; RH rotation)**
- **V6 V8 OBSD (15" - 18" - 20" pitch; RH rotation)**

*Recommended Boat Applications: Inflatables, Aluminum Consoles, Walleye Boats, Offshore Singles, Pontoons, Skiboats, Family Cruisers*



## MICHIGAN MATCH®

We pass the savings on to you in the form of a high quality, better-performing propeller that typically costs less than the engine manufacturer propeller you're replacing. Every Michigan Match® propeller features a NAVAL brass spindle with a rubber cushioned hub which absorbs impact and the stress caused by shifting gears. The rubber bushing is designed to spin free under significant impact, reducing the potential for lower unit damage. Great primary propeller, yet priced as a weekend-saver spare!

- **Improved powder coating and beefier bushing**
- **Perfect replacement propeller**
- **Available in aluminum**

*Recommended Boat Applications: Inflatables, Aluminum Consoles, Walleye Boats, Offshore Singles, Pontoons, Skiboats, Family Cruisers, Workboats, Houseboats*

# MICHIGAN PROPELLERS

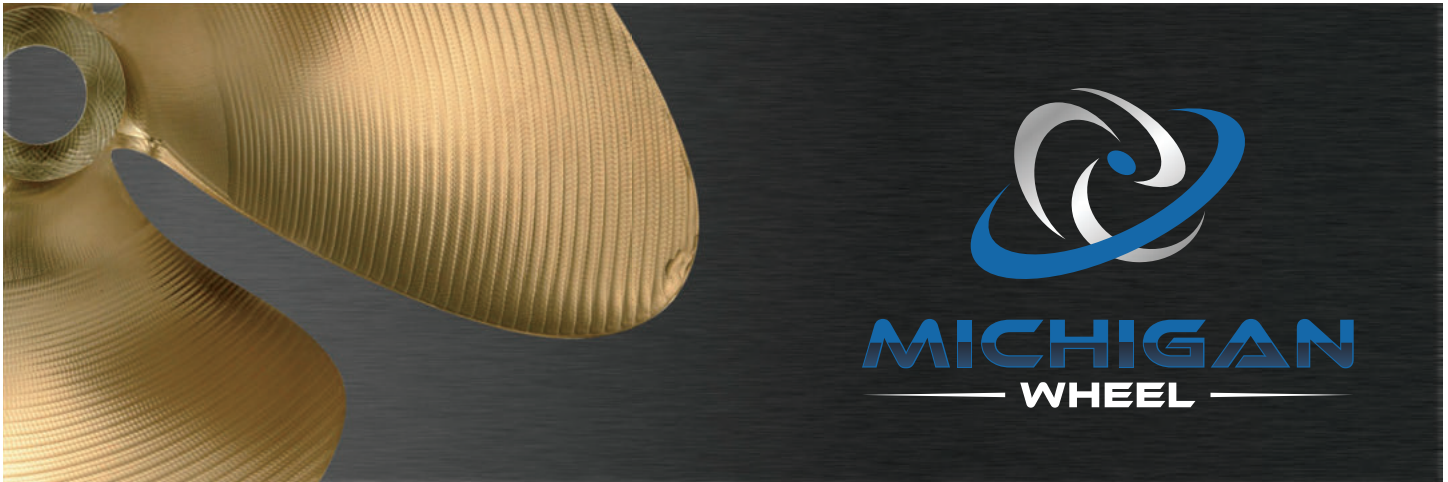

## DYNA-JET<sup>®</sup> CUPPED



Michigan Wheel's Federal Series ski boat propellers provide consistent response to your throttle commands. The 3-Blade Dyna-Jet Cupped Propellers are made of a NiBrAl alloy which provides extra strength, less flex, and greater durability. All are cupped to minimize the performance draining effects of cavitation.



| Part Number | Dia x Pitch   | Rotation | Bore   | Part Number | Dia x Pitch   | Rotation | Bore   | Part Number | Dia x Pitch | Rotation | Bore   |
|-------------|---------------|----------|--------|-------------|---------------|----------|--------|-------------|-------------|----------|--------|
| 310649      | 13" x 12"     | LH       | 1"     | 310724      | 13" x 14"     | RH       | 1"     | 310836      | 13" x 17"   | RH       | 1"     |
| 310625      | 13" x 12-1/2" | LH       | 1-1/8" | 310725      | 13" x 14"     | LH       | 1"     | 311244      | 14" x 15"   | RH       | 1"     |
| 310660      | 13" x 13"     | RH       | 1"     | 310727      | 13" x 14"     | LH       | 1-1/8" | 311284      | 14" x 16"   | RH       | 1"     |
| 310661      | 13" x 13"     | LH       | 1"     | 310763      | 13" x 15"     | LH       | 1"     | 311360      | 14" x 18"   | RH       | 1-1/8" |
| 310659      | 13" x 13"     | LH       | 1-1/8" | 310765      | 13" x 15"     | LH       | 1-1/8" | 311361      | 14" x 18"   | LH       | 1-1/8" |
| 310705      | 13" x 13-1/2" | LH       | 1-1/8" | 310801      | 13" x 15-1/2" | LH       | 1-1/8" |             |             |          |        |

# HOW TO USE APPLICATION CHART

- If the original equipment part number (OEM) is known and a size or style change is not desired, then refer to Part Number Cross Reference on Pages B8-B31 to locate the equivalent Michigan propeller.
- If an original part number is not known, the part number can not be found in the Part Number reference, or a propeller size or style change is desired, use the following procedure for selecting a propeller.

1. Locate the **BRAND** of outboard or sterndrive engine using the table of contents.
2. Locate the **HORSEPOWER/MODEL** and **YEAR** that corresponds with the engine brand.
3. Find the range of your **BOAT LENGTH**, and the boat use that best describes your vessel and usage.
4. Select the propeller **DIAMETER/PITCH** that best meets your vessel and usage. Refer to pages A3-A6 for information on choosing the right propeller.
5. Order the propeller using the **MICHIGAN PART NUMBER**. (If aluminum is desired, read across to the correct column for the part number. If stainless steel is desired, read across to the correct column for part number.)
6. If **VORTEX®**, **APOLLO®**, or **BALLISTIC®** propellers are selected, the **XHS® / XHS II® HUB KIT** indicated must be ordered.
7. Carefully read ALL notes for additional important attachment information. (If specific to a propeller, it will be noted next to the part number.)

*Unless otherwise noted: The XHS® / XHS II® hub kit is sold separately from the propeller. See pages 40-41 for XHS® / XHS II® hub kit and miscellaneous hardware information. Vortex® and Apollo® propellers fit existing Mercury Flo-Torq® II hubs. Check existing hub for wear or damage and replace if necessary with Michigan Wheel XHS® / XHS II® hub.*

**NOTE:** This is a "general" application guideline for determining the appropriate propeller size for your vessel. Performance characteristics may vary due to the many kinds of boats, hull styles, loads and style of boating.

## MERCURY®, MARINER®, SEA RAY OUTBOARDS

### 40-140 HORSEPOWER • 4-1/4" GEARCASE

Thru Hub Exhaust & 15 Tooth Spline

|                               |                    |
|-------------------------------|--------------------|
| 40 & 50 HP 4-Stroke / Bigfoot | ..... All Years    |
| 60 HP 4-Stroke / Bigfoot      | ..... 1995 & Newer |
| 60 HP (Sea Pro/Marathon)      | ..... 1995 & Newer |
| 65 HP (Model 650 - 2 Cyl.)    | ..... Thru 1971    |
| 65 HP (Model 650 - 4 Cyl.)    | ..... 1961-1970    |
| 70 HP                         | ..... 1987-1989    |
| 75 HP (Sea Pro/Marathon)      | ..... All Years    |
| 75 HP 2-Stroke                | ..... 1984-2005    |
| 75 HP 4-Stroke                | ..... 2001 & Newer |

|                               |                    |
|-------------------------------|--------------------|
| 80 HP                         | ..... 1978-1989    |
| 80 HP (Mariner®)              | ..... 1978-1983    |
| 80 HP (Model 800; 2 & 4 Cyl.) | ..... Thru 1977    |
| 80 HP (Yamaha®)               | ..... 1977-1983    |
| 85 HP (Model 850; 2 & 4 Cyl.) | ..... Thru 1977    |
| 90 HP (Yamaha®)               | ..... 1978-1983    |
| 90 HP 2-Stroke                | ..... 1978 & Newer |
| 90 HP 4-Stroke                | ..... 2001 & Newer |

|                                    |                    |
|------------------------------------|--------------------|
| 100 HP                             | ..... 1988 & Newer |
| 115 HP (Yamaha®)                   | ..... 1978-1983    |
| 115 HP                             | ..... 1978 & Newer |
| 115 HP 4-Stroke                    | ..... 2001 & Newer |
| 125 HP                             | ..... 1994-2005    |
| 140 HP (Includes Sea Pro/Offshore) | ..... 1978-1981    |
| 140 HP (Yamaha®)                   | ..... 1978-1979    |
| Models 900-1150-1500               | ..... Thru 1977    |

Includes EFI engines.

| VORTEX MICHIGAN          |      |       |       |        | APOLLO MICHIGAN          |      |       |       |        |  |
|--------------------------|------|-------|-------|--------|--------------------------|------|-------|-------|--------|--|
| 3-BL ALUMINUM - B SERIES |      |       |       |        | 4-BL ALUMINUM - B SERIES |      |       |       |        | Drop-In Hub  |
| Dia.                     | Rot. | Pitch | Bld # | Part # | Dia.                     | Rot. | Pitch | Bld # | Part # |  |
| 14                       | R    | 11    | 3     | 992111 | 13-7/8                   | R    | 11    | 4     | 941411 | Use XHS Hub Kit 202  |
| 13-3/4                   | R    | 13    | 3     | 992112 | 13-7/8                   | R    | 13    | 4     | 941413 |  |
| 13-1/2                   | R    | 15    | 3     | 992113 | 13-3/8                   | R    | 15    | 4     | 941415 | USE Gearcase Adapter Ring supplied with propeller. Refer to Pages 55-57 for Details on Hub Kit Components. |
| 13-1/4                   | R    | 17    | 3     | 992114 | 13                       | R    | 17    | 4     | 941417 |  |
| 13                       | R    | 19    | 3     | 992115 | 12-1/2                   | R    | 19    | 4     | 941419 | Drop-In Hub  |
| 13                       | R    | 21    | 3     | 992116 |                          |      |       |       |        |  |

| VORTEX MICHIGAN     |      |       |       |            | APOLLO MICHIGAN                       |      |       |       |            |  |
|---------------------|------|-------|-------|------------|---------------------------------------|------|-------|-------|------------|--|
| ALUMINUM PROPELLERS |      |       |       |            | STAINLESS STEEL - B SERIES PROPELLERS |      |       |       |            | Drop-In Hub  |
| Dia.                | Rot. | Pitch | Bld # | OEM Part # | Dia.                                  | Rot. | Pitch | Bld # | OEM Part # |  |
| 13-3/8              | R    | 15    | 3     | 993143     | 13-3/8                                | R    | 15    | 3     | 993143     | Use XHS Hub Kit 202  |
| 13-3/8              | L    | 15    | 3     | 993153     | 13-1/4                                | R    | 17    | 3     | 993144     |  |
| 13-1/4              | R    | 17    | 3     | 993144     | 13-1/4                                | L    | 17    | 3     | 993154     | USE Gearcase Adapter Ring supplied with propeller. Refer to Pages 55-57 for Details on Hub Kit Components. |
| 13-1/8              | R    | 19    | 3     | 993145     | 13-1/8                                | R    | 19    | 3     | 993155     |  |
| 13                  | R    | 21    | 3     | 993146     | 13                                    | R    | 21    | 3     | 993146     | Drop-In Hub  |
| 13                  | L    | 21    | 3     | 993156     | 13                                    | L    | 21    | 3     | 993156     |  |

| Boat Description/Length | VORTEX MICHIGAN |      |       |       |             |         |
|-------------------------|-----------------|------|-------|-------|-------------|---------|
|                         | Dia.            | Rot. | Pitch | Bld # | OEM Part #  | Part #  |
| 19'-24' - AL, SK        | 13-1/2          | R    | 15    | 3     | 48-77342A45 | 031041  |
| 17'-20' - AL, SK        | 13-1/4          | R    | 17    | 3     | 48-77344A45 | 031042  |
| 16'-19' - AL, SK        | 13              | R    | 17    | 3     | 48-77346A45 | 031043  |
| 15'-18' - AL, SK        | 13              | R    | 21    | 3     | 48-77348A45 | 031044  |
| High Performance        | 12-1/2          | R    | 23    | 3     | 48-77350A45 | 9931045 |
| High Performance        |                 |      |       |       |             |         |

| VORTEX MICHIGAN     |      |       |       |            | BALLISTIC MICHIGAN                    |      |       |       |            |  |
|---------------------|------|-------|-------|------------|---------------------------------------|------|-------|-------|------------|--|
| ALUMINUM PROPELLERS |      |       |       |            | STAINLESS STEEL - B SERIES PROPELLERS |      |       |       |            | Drop-In Hub  |
| Dia.                | Rot. | Pitch | Bld # | OEM Part # | Dia.                                  | Rot. | Pitch | Bld # | OEM Part # |  |
| 13-5/8              | R    | 15    | 3     | 9933415    | 13-5/8                                | R    | 15    | 3     | 9933415    | Use XHS II Hub Kit 202   |
| 13-1/2              | R    | 17    | 3     | 9933417    | 13-1/2                                | R    | 17    | 3     | 9933417    |  |
| 13-3/8              | R    | 19    | 3     | 9933419    | 13-3/8                                | R    | 19    | 3     | 9933419    | USE Gearcase Adapter Ring supplied with propeller. Refer to Pages 55-57 for Details on Hub Kit Components. |
| 13-1/8              | R    | 21    | 3     | 9933421    | 13-1/8                                | R    | 21    | 3     | 9933421    |  |
| 13-1/2              | R    | 22    | 3     | 9933422    | 13-1/2                                | R    | 22    | 3     | 9933422    | Drop-In Hub  |
| 13-1/2              | R    | 24    | 3     | 9933424    | 13-1/2                                | R    | 24    | 3     | 9933424    |  |

Key to Abbreviations: LL = Light Loads; SB = Sailboat; AL = All Loads; SK = Skiboat; WB = Workboat; HB = Houseboat; CR = Cruisers; HL = Heavy Loads; WD = Weedless

⊗ Limited Inventory Item.

\* To avoid damage or injury, replace standard trim tab with trim tab 822777A1.

⊗ Pontoon Boat Propeller (Extended Cup)

## 6-15 HORSEPOWER

Non-Thru Hub Exhaust & Pin Drive

|                       |                                  |                          |
|-----------------------|----------------------------------|--------------------------|
| 6 HP .....1966-1979   | 10 HP ..... 1958-1963            | 8-15 HP.....2000 & Newer |
| 9.5 HP .....1964-1973 | 10, 12, 14 HP*** ..... 1982-1994 |                          |

| Boat Description/<br>Length | MATCH<br>MICHIGAN   |      |       |       |            |        |
|-----------------------------|---------------------|------|-------|-------|------------|--------|
|                             | ALUMINUM PROPELLERS |      |       |       |            |        |
|                             | Dia.                | Rot. | Pitch | Bld # | OEM Part # | Part # |
| 14'-16' - AL                | 8-1/4               | R    | 8     | 3     | 763588     | 012008 |
| 12'-14' - LL                | 8                   | R    | 7-1/4 | 2     | 763745     | 012005 |
| 12'-14' - LL                | 8-1/4               | R    | 8-1/2 | 3     | 763586     | 012007 |



Rubber  
Hub  
Bushing  
Part # 65-098

## 8, 9.9-15 HORSEPOWER • 2-1/2" GEARCASE

Thru Hub Exhaust & 13 Tooth Spline

|                              |                                      |                                     |
|------------------------------|--------------------------------------|-------------------------------------|
| 8 HP 4-Stroke .....1996-2005 | 9.9 - 15 HP 2-Stroke ..... 1974-2005 | 9.9, 15 HP 4-Stroke ..... 1995-2001 |
|------------------------------|--------------------------------------|-------------------------------------|

| Boat Description/<br>Length | MATCH<br>MICHIGAN   |      |       |       |            |        |
|-----------------------------|---------------------|------|-------|-------|------------|--------|
|                             | ALUMINUM PROPELLERS |      |       |       |            |        |
|                             | Dia.                | Rot. | Pitch | Bld # | OEM Part # | Part # |
| 14'-16' - AL                | 10                  | R    | 7     | 3     | 763456     | 012112 |
| Standard Replacement        | 9-1/2               | R    | 10    | 3     | 778772     | 012111 |



Rubber  
Hub  
Bushing  
Part # 65-234

## 9.9-15 HORSEPOWER • JOHNSON • 2-1/2" GEARCASE

Thru Hub Exhaust & 10 Tooth Spline

|                                |                                |
|--------------------------------|--------------------------------|
| 9.9 HP 4-Stroke .....2002-2007 | 15 HP 4-Stroke ..... 2002-2007 |
|--------------------------------|--------------------------------|

| Boat Description/<br>Length | MATCH<br>MICHIGAN   |      |       |       |            |        |
|-----------------------------|---------------------|------|-------|-------|------------|--------|
|                             | ALUMINUM PROPELLERS |      |       |       |            |        |
|                             | Dia.                | Rot. | Pitch | Bld # | OEM Part # | Part # |
| 14'-19' - AL                | 9-1/4               | R    | 9     | 3     | 5005384    | 062103 |
| 14'-19' - AL                | 9-1/4               | R    | 10    | 3     | 5005385    | 062104 |
| 14'-16' - LL                | 9-1/4               | R    | 11    | 3     | 5033203    | 062105 |



Rubber  
Hub  
Bushing  
Part # 65-298

## 9.8 HORSEPOWER

Thru Hub Exhaust & 12 Tooth Spline

|                                   |
|-----------------------------------|
| 9.8 HP 4-Stroke .....2012 & Newer |
|-----------------------------------|

| Boat Description/<br>Length | MATCH<br>MICHIGAN   |      |       |       |            |        |
|-----------------------------|---------------------|------|-------|-------|------------|--------|
|                             | ALUMINUM PROPELLERS |      |       |       |            |        |
|                             | Dia.                | Rot. | Pitch | Bld # | OEM Part # | Part # |
|                             | 8-1/2               | R    | 7     | 3     | 5040538    | 142102 |
|                             | 8-1/2               | R    | 8     | 3     |            | 142103 |



Rubber  
Hub  
Bushing  
Part # 65-531



**15 HORSEPOWER**

Thru Hub Exhaust & 14 Tooth Spline

15 HP 4-Stroke.....2012 & Newer

| Boat Description/<br>Length | MATCH MICHIGAN      |      |       |       |            |        |
|-----------------------------|---------------------|------|-------|-------|------------|--------|
|                             | ALUMINUM PROPELLERS |      |       |       |            |        |
|                             | Dia.                | Rot. | Pitch | Bld # | OEM Part # | Part # |
| 14'-19' - AL                | 9-1/4               | R    | 8     | 3     |            | 142203 |
| Standard Replacement        | 9-1/4               | R    | 9     | 3     | 5040590    | 142204 |
| Standard Replacement        | 9-1/4               | R    | 10    | 3     | 5040591    | 142205 |
| 14'-16' - LL                | 9-1/4               | R    | 11    | 3     | 5040592    | 142206 |
| Up to 16' - LL              | 9-1/4               | R    | 12    | 3     |            | 142207 |



**142206**

142204 Standard Replacement for:  
• 20" Shaft Length  
• 25" Shaft Length

142205 Standard Replacement for:  
• 15" Shaft Length



Rubber Hub Bushing  
Part # 65-369

**10-28 HORSEPOWER**

Non-Thru Hub Exhaust & Pin Drive

10 HP.....1951-1957      18 HP.....1957-1973      25 HP.....1969-1977  
 15 HP.....1953-1956      20 HP.....1969-1973      28 HP.....1964

| Boat Description/<br>Length | MATCH MICHIGAN      |      |       |       |            |        |
|-----------------------------|---------------------|------|-------|-------|------------|--------|
|                             | ALUMINUM PROPELLERS |      |       |       |            |        |
|                             | Dia.                | Rot. | Pitch | Bld # | OEM Part # | Part # |
| CR, HB, SB                  | 9-1/4               | R    | 7     | 3     | 388294     | 012102 |
| 14'-16' - HL                | 9                   | R    | 9     | 3     | 763587     | 012109 |
| 12'-14' - LL                | 9                   | R    | 10    | 3     | 763583     | 012011 |
| 12'-14' - LL                | 9-1/4               | R    | 11    | 3     |            | 012013 |

012102

012011

012013



Rubber Hub Bushing  
Part # 65-079

**14-28 HORSEPOWER**

Non-Thru Hub Exhaust & 13 Tooth Spline

14 HP.....1988-1989      25 HP\*\*.....1978-1991; 1994 & Newer      28 HP.....1986-1996  
 25 HP.....1978-1984

| Boat Description/<br>Length | MATCH MICHIGAN      |      |       |       |            |        |
|-----------------------------|---------------------|------|-------|-------|------------|--------|
|                             | ALUMINUM PROPELLERS |      |       |       |            |        |
|                             | Dia.                | Rot. | Pitch | Bld # | OEM Part # | Part # |
| 16'-18' - HL                | 9                   | R    | 9     | 3     | 763585     | 012021 |
| 15'-17' - AL                | 9                   | R    | 10    | 3     | 763589     | 012015 |
| 14'-17' - AL                | 9-1/4               | R    | 11    | 3     | 763584     | 012016 |
| 14'-17' - LL                | 9-1/4               | R    | 12    | 3     | 763590     | 012030 |

012015

012016

012030

Rubber Hub Bushing  
Part # 65-281

**25-40 HORSEPOWER**

Non-Thru Hub Exhaust & Pin Drive

25 HP.....1951-1955      33 HP.....1965-1970      40 HP.....1960-1976  
 28 HP.....1962-1964      35 HP.....1957-1959      40 HP\*\*.....1978-1985  
 30 HP.....1956

| Boat Description/<br>Length | MATCH MICHIGAN      |      |        |       |            |        |
|-----------------------------|---------------------|------|--------|-------|------------|--------|
|                             | ALUMINUM PROPELLERS |      |        |       |            |        |
|                             | Dia.                | Rot. | Pitch  | Bld # | OEM Part # | Part # |
| 17'-19' - AL, SK            | 10-3/8              | R    | 11-1/2 | 3     |            | 012023 |
| 14'-16' - AL, SK            | 10-1/2              | R    | 12     | 3     |            | 012024 |



012023

Rubber Hub Bushing  
Part # 65-126

EVINRUDE / JOHNSON

**25-30 HORSEPOWER (4-STROKE) • 3" GEARCASE**

Thru Hub Exhaust & 10 Tooth Spline • **!** MUST use Gearcase Adapter Ring supplied with propeller.

25 HP 4-Stroke .....2004-2007      30 HP 4-Stroke ..... 2004-2007

| Boat Description/<br>Length | <b>VORTEX</b><br>MICHIGAN      |      |       |       |            |        |
|-----------------------------|--------------------------------|------|-------|-------|------------|--------|
|                             | ALUMINUM - E SERIES PROPELLERS |      |       |       |            |        |
|                             | Dia.                           | Rot. | Pitch | Bld # | OEM Part # | Part # |
| 20' & Up - AL               | 10-1/2                         | R    | 9     | 3     |            | 992501 |
| 17'-20' - AL                | 10-1/2                         | R    | 10    | 3     |            | 992502 |
| 17'-20' - AL                | 10-1/2                         | R    | 11    | 3     |            | 992503 |
| 15'-18' - AL                | 10-1/8                         | R    | 12    | 3     |            | 992504 |
| 13'-15' - AL                | 10-1/8                         | R    | 13    | 3     |            | 992505 |
| Up to 15' - LL              | 10-1/8                         | R    | 14    | 3     |            | 992506 |

Drop-In Hub  
Use XHS® or XHS II® Hub Kit  
**121** OR **221**  
**!**



| Boat Description/<br>Length | <b>MATCH</b><br>MICHIGAN |      |       |       |            |        |
|-----------------------------|--------------------------|------|-------|-------|------------|--------|
|                             | ALUMINUM PROPELLERS      |      |       |       |            |        |
|                             | Dia.                     | Rot. | Pitch | Bld # | OEM Part # | Part # |
| 20' & Up - AL               | 10-1/4                   | R    | 9     | 3     | 5032171    | 062208 |
| 20' & Up - AL               | 10-1/4                   | R    | 10    | 3     | 5032107    | 062204 |
| 17'-20' - AL                | 10-1/4                   | R    | 11    | 3     | 5032108    | 062205 |
| 15'-18' - AL                | 10-1/4                   | R    | 12    | 3     | 5032109    | 062206 |
| 13'-15' - AL                | 10-1/4                   | R    | 13    | 3     | 5032110    | 062207 |
| 13'-15' - AL                | 10-1/4                   | R    | 14    | 3     | 5032106    | 062209 |
| Up to 15' - LL              | 10-1/4                   | R    | 15    | 3     |            | 062210 |

Rubber Hub Bushing  
Part # 65-339

| Boat Description/<br>Length | <b>BALLISTIC</b><br>MICHIGAN          |      |       |       |            |          |
|-----------------------------|---------------------------------------|------|-------|-------|------------|----------|
|                             | STAINLESS STEEL - E SERIES PROPELLERS |      |       |       |            |          |
|                             | Dia.                                  | Rot. | Pitch | Bld # | OEM Part # | Part #   |
|                             |                                       |      |       |       |            |          |
|                             |                                       |      |       |       |            |          |
|                             |                                       |      |       |       |            |          |
|                             | 10-1/8                                | R    | 13    | 3     |            | * 933013 |
|                             |                                       |      |       |       |            |          |
|                             | 10-1/8                                | R    | 15    | 3     |            | * 933015 |

Drop-In Hub  
Use XHS® or XHS II® Hub Kit  
**121** OR **221**  
**!**

\* May interfere with trim tab.

**15-35 HORSEPOWER • 3" GEARCASE**

Thru Hub Exhaust & 14 Tooth Spline • **!** MUST use Gearcase Adapter Ring supplied with propeller. • VORTEX® PROPELLER MAY INTERFERE WITH SKEG ON ANY MODEL

15 HP E-TEC®H.O.....2011 & Newer      25 HP 2 & 3 Cyl.....1984 & Newer      30 HP E-TEC® .....2009 & Newer  
20 HP 2 Cyl.....1984-1997      25 HP E-TEC® .....2009 & Newer      35 HP 2 Cyl ..... 1979-1983  
25 HP (Commercial).....1993-2005      30 HP 2 Cyl.....1984 & Newer      35 HP 3 Cyl ..... 1997-2001

| Boat Description/<br>Length | <b>VORTEX</b><br>MICHIGAN      |      |       |       |            |        |
|-----------------------------|--------------------------------|------|-------|-------|------------|--------|
|                             | ALUMINUM - E SERIES PROPELLERS |      |       |       |            |        |
|                             | Dia.                           | Rot. | Pitch | Bld # | OEM Part # | Part # |
| 17'-20' - AL, SK            | 10-1/2                         | R    | 9     | 3     |            | 992501 |
| 17'-20' - AL, SK            | 10-1/2                         | R    | 10    | 3     |            | 992502 |
| 16'-18' - AL, SK            | 10-1/2                         | R    | 11    | 3     | 765049     | 992503 |
| 16'-18' - AL, SK            | 10-1/8                         | R    | 12    | 3     |            | 992504 |
| 15'-17' - AL, SK            | 10-1/8                         | R    | 13    | 3     | 778863     | 992505 |
| 13'-15' - AL, SK            | 10-1/8                         | R    | 14    | 3     |            | 992506 |

Drop-In Hub  
Use XHS® or XHS II® Hub Kit  
**118** OR **218**  
**!**



| Boat Description/<br>Length | <b>MATCH</b><br>MICHIGAN |      |       |       |            |        |
|-----------------------------|--------------------------|------|-------|-------|------------|--------|
|                             | ALUMINUM PROPELLERS      |      |       |       |            |        |
|                             | Dia.                     | Rot. | Pitch | Bld # | OEM Part # | Part # |
| 17'-20' - AL, SK            | 11                       | R    | 9     | 3     | 765048     | 012054 |
| 16'-18' - AL, SK            | 10-1/2                   | R    | 11    | 3     | 765049     | 012055 |
| 15'-17' - AL, SK            | 10                       | R    | 13    | 3     | 778863     | 012056 |
| 13'-15' - AL, SK            | 10                       | R    | 15    | 3     | 763486     | 012057 |
| 15'-17' - AL, SK            | 10                       | R    | 13    | 3     | 778863     | 012213 |

Rubber Hub Bushing  
Part # 65-251

| Boat Description/<br>Length | <b>BALLISTIC</b><br>MICHIGAN          |      |       |       |            |        |
|-----------------------------|---------------------------------------|------|-------|-------|------------|--------|
|                             | STAINLESS STEEL - E SERIES PROPELLERS |      |       |       |            |        |
|                             | Dia.                                  | Rot. | Pitch | Bld # | OEM Part # | Part # |
|                             |                                       |      |       |       |            |        |
|                             |                                       |      |       |       |            |        |
|                             |                                       |      |       |       |            |        |
|                             | 10-1/8                                | R    | 13    | 3     |            | 933013 |
|                             | 10-1/8                                | R    | 15    | 3     |            | 933015 |

Drop-In Hub  
Use XHS® or XHS II® Hub Kit  
**118** OR **218**  
**!**

**40-50 HORSEPOWER • JOHNSON • 3-1/4" GEARCASE**

Thru Hub Exhaust & 13 Tooth Spline

40 HP 4-Stroke .....1999-2005      50 HP 4-Stroke ..... 1999-2005

| ALUMINUM - D SERIES PROPELLERS |      |       |        |                      |      |       |        |
|--------------------------------|------|-------|--------|----------------------|------|-------|--------|
| 3-BLADE                        |      |       |        | LG. DIAMETER 3-BLADE |      |       |        |
| Dia.                           | Rot. | Pitch | Part # | Dia.                 | Rot. | Pitch | Part # |
|                                |      |       |        |                      |      |       |        |
|                                |      |       |        |                      |      |       |        |
|                                |      |       |        |                      |      |       |        |
| 10-3/8                         | R    | 11    | 992404 | 11-5/8               | R    | 11    | 992603 |
| 10-3/8                         | R    | 12    | 992405 | 11-3/8               | R    | 12    | 992604 |
| 10-3/8                         | R    | 13    | 992406 | 11-1/8               | R    | 13    | 992605 |
| 10-3/8                         | R    | 14    | 992407 | 11-1/4               | R    | 14    | 992606 |
| 10                             | R    | 15    | 992408 |                      |      |       |        |
| 10                             | R    | 16    | 992409 |                      |      |       |        |

**Drop-In Hub**  
Use XHS® or XHS II® Hub Kit  
**115 OR 215**  
Refer to Pages 55-57 for Details on Hub Kit Components.

| STAINLESS STEEL - D SERIES PROPELLERS |      |       |       |            |        |  |
|---------------------------------------|------|-------|-------|------------|--------|--|
| Dia.                                  | Rot. | Pitch | Bld # | OEM Part # | Part # |  |
|                                       |      |       |       |            |        |  |
|                                       |      |       |       |            |        |  |
| 10-3/4                                | R    | 12    | 3     |            | 993405 |  |
| 10-1/2                                | R    | 13    | 3     |            | 993406 |  |
| 10-3/8                                | R    | 14    | 3     |            | 993407 |  |
| 10-1/8                                | R    | 15    | 3     |            | 993408 |  |

**Drop-In Hub**  
Use XHS® or XHS II® Hub Kit  
**115 OR 215**  
Refer to Pages 55-57 for Details on Hub Kit Components.

| Boat Description/<br>Length |                     |      |       |       |            |        |
|-----------------------------|---------------------|------|-------|-------|------------|--------|
|                             | ALUMINUM PROPELLERS |      |       |       |            |        |
|                             | Dia.                | Rot. | Pitch | Bld # | OEM Part # | Part # |
| 18'-21' - AL                | 12-1/4              | R    | 9     | 3     | 776807     | 032046 |
| 18'-21' - AL                | 11-3/4              | R    | 10    | 3     | 778606     | 032045 |
| 16'-19' - AL                | 11-1/2              | R    | 11    | 3     | 778607     | 062211 |
| 16'-19' - AL                | 11-1/2              | R    | 12    | 3     | 778608     | 062212 |
| 14'-18' - AL                | 11-1/2              | R    | 13    | 3     | 778609     | 062213 |
| 14'-18' - AL                | 11-1/2              | R    | 14    | 3     | 778610     | 062214 |
| 13'-15' - AL                | 11-1/4              | R    | 15    | 3     |            | 062215 |
| 13'-15' - LL                | 11-1/8              | R    | 16    | 3     |            | 062216 |
| Up to 15' - LL              | 11                  | R    | 17    | 3     |            | 062217 |

**Rubber Hub Bushing**  
Part # 65-205

| STAINLESS STEEL - D SERIES PROPELLERS |      |       |       |            |        |  |
|---------------------------------------|------|-------|-------|------------|--------|--|
| Dia.                                  | Rot. | Pitch | Bld # | OEM Part # | Part # |  |
|                                       |      |       |       |            |        |  |
|                                       |      |       |       |            |        |  |
| 10-1/8                                | R    | 13    | 3     |            | 933213 |  |
| 10-1/8                                | R    | 15    | 3     |            | 933215 |  |

**Drop-In Hub**  
Use XHS® or XHS II® Hub Kit  
**115 OR 215**  
Refer to Pages 55-57 for Details on Hub Kit Components.

**40-75 HORSEPOWER • SMALL (3-3/8") GEARCASE**

Thru Hub Exhaust & 13 Tooth Spline

40 HP 2 Cyl. ....1984-2005      55 HP ..... 1976-1979      75 HP 3 Cyl. .... 1975-1985  
48 HP .....1987-1996      65 HP 2 Cyl. .... 1980-1985      Sprint/Formula E ..... 1986-1992  
50 HP 2 Cyl. ....1975-2005

| ALUMINUM - C SERIES PROPELLERS |      |       |        |                      |      |       |        |
|--------------------------------|------|-------|--------|----------------------|------|-------|--------|
| 3-BLADE                        |      |       |        | LG. DIAMETER 3-BLADE |      |       |        |
| Dia.                           | Rot. | Pitch | Part # | Dia.                 | Rot. | Pitch | Part # |
|                                |      |       |        |                      |      |       |        |
|                                |      |       |        |                      |      |       |        |
|                                |      |       |        |                      |      |       |        |
| 11-3/4                         | R    | 13    | 992301 | 12-1/2               | R    | 13    | 992311 |
| 11-3/4                         | R    | 15    | 992302 | 12-1/4               | R    | 15    | 992312 |
| 11-3/4                         | R    | 17    | 992303 |                      |      |       |        |

**Drop-In Hub**  
Use XHS® or XHS II® Hub Kit  
**111 OR 211**  
Refer to Pages 55-57 for Details on Hub Kit Components.



| Boat Description/<br>Length |                     |      |       |       |            |        |
|-----------------------------|---------------------|------|-------|-------|------------|--------|
|                             | ALUMINUM PROPELLERS |      |       |       |            |        |
|                             | Dia.                | Rot. | Pitch | Bld # | OEM Part # | Part # |
| CR, HB                      | 13                  | R    | 11    | 3     | 763488     | 012036 |
| 15'-18' - AL, SK            | 12-1/2              | R    | 13    | 3     | 763461     | 012037 |
| 14'-17' - AL, SK            | 12-1/4              | R    | 15    | 3     | 778774     | 011027 |
| 13'-15' - LL                | 11-3/4              | R    | 17    | 3     | 763462     | 011028 |

**Rubber Hub Bushing**  
Part # 65-241

| STAINLESS STEEL - C SERIES PROPELLERS |      |       |       |            |        |  |
|---------------------------------------|------|-------|-------|------------|--------|--|
| Dia.                                  | Rot. | Pitch | Bld # | OEM Part # | Part # |  |
|                                       |      |       |       |            |        |  |
|                                       |      |       |       |            |        |  |
| 12-3/8                                | R    | 15    | 3     |            | 933315 |  |
| 12                                    | R    | 17    | 3     |            | 933317 |  |

**Drop-In Hub**  
Use XHS® or XHS II® Hub Kit  
**111 OR 211**  
Refer to Pages 55-57 for Details.

## 40-75 HORSEPOWER • LARGE (4-1/4") GEARCASE

Thru Hub Exhaust & 13 Tooth Spline

|                               |              |
|-------------------------------|--------------|
| 40 HP E-TEC® .....            | 2004 & Newer |
| 45 HP 2 Cyl. Commercial ..... | 1986-1995    |
| 50 HP E-TEC® .....            | 2004 & Newer |
| 50 HP 2 Cyl. Commercial ..... | 1977-1979    |
| 50 HP 2 Cyl. Pleasure .....   | 1971-1974    |
| 50 HP 3 Cyl. Pleasure .....   | 1994-1998    |
| 55 HP 3 Cyl. ....             | 1968-1969    |

|                               |                      |
|-------------------------------|----------------------|
| 55 HP 2 Cyl. Commercial ..... | 1980 & Newer         |
| 55 HP E-TEC® .....            | 2009 & Newer         |
| 60 HP 3 Cyl. Pleasure .....   | 1970-1971; 1986-2001 |
| 60 HP E-TEC® .....            | 2004 & Newer         |
| 60 HP 4-Stroke .....          | 1998 & Newer         |
| 65 HP 3 Cyl. Pleasure .....   | 1972-1973            |
| 65 HP 3 Cyl. Commercial ..... | 1984-2001            |

|                               |              |
|-------------------------------|--------------|
| 65 HP Pontoon Series .....    | 2014 & Newer |
| 70 HP 3 Cyl. Pleasure .....   | 1974 & Newer |
| 70 HP 3 Cyl. Commercial ..... | 1974-2001    |
| 70 HP 4-Stroke .....          | 1998 & Newer |
| 75 HP 3 Cyl. Pleasure .....   | 1975-1984    |
| 75 HP E-TEC® .....            | 2004 & Newer |

### VORTEX MICHIGAN

| 3-BL ALUMINUM - B SERIES |      |       |       |        | 4-BL ALUMINUM - B SERIES |      |       |       |        |
|--------------------------|------|-------|-------|--------|--------------------------|------|-------|-------|--------|
| Dia.                     | Rot. | Pitch | Bld # | Part # | Dia.                     | Rot. | Pitch | Bld # | Part # |
| 14                       | R    | 10    | 3     | 992109 |                          |      |       |       |        |
| 14                       | R    | 11    | 3     | 992111 | 13-7/8                   | R    | 11    | 4     | 941411 |
| 14                       | R    | 13    | 3     | 992112 | 13-7/8                   | R    | 13    | 4     | 941413 |
| 13-3/4                   | R    | 15    | 3     | 992113 | 13-3/8                   | R    | 15    | 4     | 941415 |
|                          |      |       |       |        |                          |      |       |       |        |
| 13-1/4                   | R    | 17    | 3     | 992114 | 13                       | R    | 17    | 4     | 941417 |
|                          |      |       |       |        |                          |      |       |       |        |
| 13                       | R    | 19    | 3     | 992115 | 12-1/2                   | R    | 19    | 4     | 941419 |
|                          |      |       |       |        |                          |      |       |       |        |
| 12-3/4                   | R    | 21    | 3     | 992116 |                          |      |       |       |        |

Drop-In Hub

Use XHS II® Hub Kit **206 / 210**

Do NOT use Gearcase Adapter Ring supplied with propeller.

Refer to Pages 55-57 for Details on Hub Kit Components.

### APOLLO MICHIGAN

| STAINLESS STEEL - B SERIES PROPELLERS |      |       |       |            |        |
|---------------------------------------|------|-------|-------|------------|--------|
| Dia.                                  | Rot. | Pitch | Bld # | OEM Part # | Part # |
|                                       |      |       |       |            |        |
|                                       |      |       |       |            |        |
| 13-3/8                                | R    | 15    | 3     | 763950     | 993143 |
| 13-3/8                                | L    | 15    | 3     |            | 993153 |
| 13-1/4                                | R    | 17    | 3     | 763951     | 993144 |
| 13-1/4                                | L    | 17    | 3     |            | 993154 |
| 13-1/8                                | R    | 19    | 3     | 763952     | 993145 |
| 13-1/8                                | L    | 19    | 3     |            | 993155 |
| 13                                    | R    | 21    | 3     |            | 993146 |
| 13                                    | L    | 21    | 3     |            | 993156 |

Drop-In Hub

Use XHS II® Hub Kit **206 / 210**

Do NOT use Gearcase Adapter Ring supplied with propeller.

Refer to Pages 55-57 for Details on Hub Kit Components.

### MATCH MICHIGAN

| Boat Description/<br>Length | ALUMINUM PROPELLERS |      |       |       |            |          |
|-----------------------------|---------------------|------|-------|-------|------------|----------|
|                             | Dia.                | Rot. | Pitch | Bld # | OEM Part # | Part #   |
| CR, HB                      | 14                  | R    | 11    | 3     | 763301     | 012047   |
| 19'-22' - AL                | 14                  | R    | 13    | 3     | ◆ 765181   | 011001   |
| 17'-19' - AL                | 13-3/4              | R    | 15    | 3     | ◆ 765182   | 011002   |
| 15'-17' - AL                | 13-1/4              | R    | 17    | 3     | ◆ 765183   | 011003   |
| 15'-17' - AL, SK            | 14                  | R    | 17    | 3     | 176214     | * 011024 |
| 14'-16' - AL                | 13                  | R    | 19    | 3     | ◆ 765184   | 011004   |
| 14'-16' - AL, SK            | 14                  | R    | 19    | 3     | 176215     | * 011025 |
| 13'-15' - AL, SK            | 12-3/4              | R    | 21    | 3     | ◆ 765185   | 011005   |
| 14'-16' - AL                | 13-1/4              | R    | 19    | 3     | ◆ 765184   | 011419   |

Rubber Hub Bushing Part # 65-172

### BALLISTIC MICHIGAN

| STAINLESS STEEL - B SERIES PROPELLERS |      |       |       |            |        |
|---------------------------------------|------|-------|-------|------------|--------|
| Dia.                                  | Rot. | Pitch | Bld # | OEM Part # | Part # |
|                                       |      |       |       |            |        |
|                                       |      |       |       |            |        |
| 13-5/8                                | R    | 15    | 3     |            | 933415 |
| 13-1/2                                | R    | 17    | 3     |            | 933417 |
|                                       |      |       |       |            |        |
| 13-3/8                                | R    | 19    | 3     |            | 933419 |
|                                       |      |       |       |            |        |
| 13-1/8                                | R    | 21    | 3     |            | 933421 |

Drop-In Hub

Use XHS II® Hub Kit **206 / 210**

Do NOT use Gearcase Adapter Ring supplied with propeller.

Refer to Pages 55-57 for Details on Hub Kit Components.

Note: For 60 HP & 70 HP 4-Stroke engine applications, 1998 & Newer, use XHS II® (Drop-In Hub) Kit # 210. For all other engine applications use XHS II® (Drop-In Hub) Kit # 206.

Note: ◆ When replacing Interchangeable Hub Evinrude® aluminum propeller with Michigan Match, Michigan Match Thrust Washer P/N 990406 is required.



011003



011024



941413

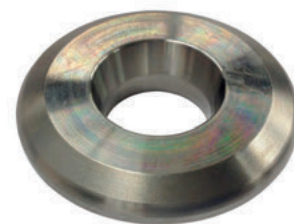

990406



Key to Abbreviations: LL = Light Loads; SB = Sailboat; AL = All Loads; SK = Skiboat; WB = Workboat; HB = Houseboat; CR = Cruisers; HL = Heavy Loads; WD = Weedless

\* If currently using uncupped propeller, use cupped propeller having 2" less pitch. Boats with power trim use same pitch.

## 85-140 HORSEPOWER • V-4 (4-1/4") GEARCASE

Thru Hub Exhaust & 13 Tooth Spline

|                                      |                      |
|--------------------------------------|----------------------|
| 85 HP.....                           | 1969-1980; 1991-1995 |
| 88 HP.....                           | 1981-1996            |
| 90 HP.....                           | 1981 & Newer         |
| 90 HP E-TEC® (20" Shaft Length)..... | 2004 & Newer         |
| 90 HP Pontoon Series .....           | 2014 & Newer         |

|                                       |                      |
|---------------------------------------|----------------------|
| 100 HP.....                           | 1979-1980; 1989-1993 |
| 110 HP.....                           | 1986-1989            |
| 112 HP.....                           | 1994-1996            |
| 115 HP.....                           | 1973 & Newer         |
| 115 HP E-TEC® (20" Shaft Length)..... | 2004 & Newer         |

|                                       |           |
|---------------------------------------|-----------|
| 120 HP.....                           | 1986-1994 |
| 125 HP.....                           | 1971-1972 |
| 130 HP E-TEC® (20" Shaft Length)..... | 2004-2010 |
| 135 HP.....                           | 1973-1976 |
| 140 HP.....                           | 1977-1994 |

### VORTEX MICHIGAN

### APOLLO MICHIGAN

| 3-BL ALUMINUM - B SERIES |      |       |       |        | 4-BL ALUMINUM - B SERIES |      |       |       |        |
|--------------------------|------|-------|-------|--------|--------------------------|------|-------|-------|--------|
| Dia.                     | Rot. | Pitch | Bld # | Part # | Dia.                     | Rot. | Pitch | Bld # | Part # |
| 14                       | R    | 10    | 3     | 992109 |                          |      |       |       |        |
| 14                       | R    | 11    | 3     | 992111 | 13-7/8                   | R    | 11    | 4     | 941411 |
| 14                       | R    | 13    | 3     | 992112 | 13-7/8                   | R    | 13    | 4     | 941413 |
| 13-3/4                   | R    | 15    | 3     | 992113 | 13-3/8                   | R    | 15    | 4     | 941415 |
|                          |      |       |       |        |                          |      |       |       |        |
| 13-1/4                   | R    | 17    | 3     | 992114 | 13                       | R    | 17    | 4     | 941417 |
|                          |      |       |       |        |                          |      |       |       |        |
| 13                       | R    | 19    | 3     | 992115 | 12-1/2                   | R    | 19    | 4     | 941419 |
|                          |      |       |       |        |                          |      |       |       |        |
| 12-3/4                   | R    | 21    | 3     | 992116 |                          |      |       |       |        |

Drop-In Hub

Use XHS II® Hub Kit

**206**

Do NOT use Gearcase Adapter Ring supplied with propeller.

Refer to Pages 55-57 for Details on Hub Kit Components.

| STAINLESS STEEL - B SERIES PROPELLERS |      |       |       |            |        |
|---------------------------------------|------|-------|-------|------------|--------|
| Dia.                                  | Rot. | Pitch | Bld # | OEM Part # | Part # |
|                                       |      |       |       |            |        |
| 13-3/8                                | R    | 15    | 3     | 763950     | 993143 |
| 13-3/8                                | L    | 15    | 3     |            | 993153 |
| 13-1/4                                | R    | 17    | 3     | 763951     | 993144 |
| 13-1/4                                | L    | 17    | 3     |            | 993154 |
| 13-1/8                                | R    | 19    | 3     | 763952     | 993145 |
| 13-1/8                                | L    | 19    | 3     |            | 993155 |
| 13                                    | R    | 21    | 3     |            | 993146 |
| 13                                    | L    | 21    | 3     |            | 993156 |

Drop-In Hub

Use XHS II® Hub Kit

**206**

Do NOT use Gearcase Adapter Ring supplied with propeller.

Refer to Pages 55-57 for Details on Hub Kit Components.

### MATCH MICHIGAN

### BALLISTIC MICHIGAN

| Boat Description/Length | ALUMINUM PROPELLERS |      |       |       |            |        |
|-------------------------|---------------------|------|-------|-------|------------|--------|
|                         | Dia.                | Rot. | Pitch | Bld # | OEM Part # | Part # |
| CR, HB                  | 14                  | R    | 11    | 3     | 763301     | 012047 |
| CR, HB                  | 14                  | R    | 13    | 3     | ◆ 765181   | 011001 |
| 20'-24' - AL            | 13-3/4              | R    | 15    | 3     | ◆ 765182   | 011002 |
| 19'-22' - AL            | 13-1/4              | R    | 17    | 3     | ◆ 765183   | 011003 |
| 19'-22' - AL, SK        | 14                  | R    | 17    | 3     | 176214     | 011024 |
| 17'-19' - AL            | 13                  | R    | 19    | 3     | ◆ 765184   | 011004 |
| 17'-19' - AL, SK        | 14                  | R    | 19    | 3     | 176215     | 011025 |
| 15'-18' - AL, SK        | 12-3/4              | R    | 21    | 3     | ◆ 765185   | 011005 |
| 14'-16' - AL            | 13-1/4              | R    | 19    | 3     | ◆ 765184   | 011419 |
| High Performance        |                     |      |       |       |            |        |
| High Performance        |                     |      |       |       |            |        |

Rubber Hub Bushing Part # 65-172

| STAINLESS STEEL - B SERIES PROPELLERS |      |       |       |        |                          |      |       |       |        |
|---------------------------------------|------|-------|-------|--------|--------------------------|------|-------|-------|--------|
| 3-BLADE BALLISTIC XHS                 |      |       |       |        | 3-BLADE BALLISTIC XHS XL |      |       |       |        |
| Dia.                                  | Rot. | Pitch | Bld # | Part # | Dia.                     | Rot. | Pitch | Bld # | Part # |
|                                       |      |       |       |        |                          |      |       |       |        |
| 13-5/8                                | R    | 15    | 3     | 933415 |                          |      |       |       |        |
| 13-1/2                                | R    | 17    | 3     | 933417 |                          |      |       |       |        |
|                                       |      |       |       |        |                          |      |       |       |        |
| 13-3/8                                | R    | 19    | 3     | 933419 |                          |      |       |       |        |
|                                       |      |       |       |        |                          |      |       |       |        |
| 13-1/8                                | R    | 21    | 3     | 933421 |                          |      |       |       |        |
|                                       |      |       |       |        |                          |      |       |       |        |
|                                       |      |       |       |        | 13-1/2                   | R    | 22    | 3     | 953422 |
|                                       |      |       |       |        | 13-1/2                   | R    | 24    | 3     | 953424 |

Drop-In Hub

Use XHS II® Hub Kit

**206**

Do NOT use Gearcase Adapter Ring supplied with propeller.

Refer to Pages 55-57 for Details on Hub Kit Components.

Note: ◆ When replacing Interchangeable Hub Evinrude® aluminum propeller with Michigan Match, Michigan Match Thrust Washer P/N 990406 is required.



**MATCH** MICHIGAN



**VORTEX** MICHIGAN



**APOLLO** MICHIGAN



**BALLISTIC** MICHIGAN

EVINRUDE / JOHNSON

## 90, 115 & 140 HORSEPOWER • JOHNSON • 4-1/4" GEARCASE Thru Hub Exhaust & 15 Tooth Spline

90 HP 4-Stroke .....2002-2005      115 HP 4-Stroke ..... 2002-2005      140 HP 4-Stroke ..... 2002-2005

| VORTEX<br>MICHIGAN       |      |       |                          |        |        | APOLLO<br>MICHIGAN                    |       |       |        |        |      |       |       |            |        |
|--------------------------|------|-------|--------------------------|--------|--------|---------------------------------------|-------|-------|--------|--------|------|-------|-------|------------|--------|
| 3-BL ALUMINUM - B SERIES |      |       | 4-BL ALUMINUM - B SERIES |        |        | STAINLESS STEEL - B SERIES PROPELLERS |       |       |        |        |      |       |       |            |        |
| Dia.                     | Rot. | Pitch | Bld #                    | Part # | Dia.   | Rot.                                  | Pitch | Bld # | Part # | Dia.   | Rot. | Pitch | Bld # | OEM Part # | Part # |
| 14                       | R    | 10    | 3                        | 992109 |        |                                       |       |       |        |        |      |       |       |            |        |
| 14                       | R    | 11    | 3                        | 992111 | 13-7/8 | R                                     | 11    | 4     | 941411 |        |      |       |       |            |        |
| 14                       | R    | 13    | 3                        | 992112 | 13-7/8 | R                                     | 13    | 4     | 941413 |        |      |       |       |            |        |
| 13-3/4                   | R    | 15    | 3                        | 992113 | 13-3/8 | R                                     | 15    | 4     | 941415 | 13-3/8 | R    | 15    | 3     | 763950     | 993143 |
|                          |      |       |                          |        |        |                                       |       |       |        | 13-3/8 | L    | 15    | 3     |            | 993153 |
| 13-1/4                   | R    | 17    | 3                        | 992114 | 13     | R                                     | 17    | 4     | 941417 | 13-1/4 | R    | 17    | 3     | 793951     | 993144 |
|                          |      |       |                          |        |        |                                       |       |       |        | 13-1/4 | L    | 17    | 3     |            | 993154 |
| 13                       | R    | 19    | 3                        | 992115 | 12-1/2 | R                                     | 19    | 4     | 941419 | 13-1/8 | R    | 19    | 3     | 763952     | 993145 |
|                          |      |       |                          |        |        |                                       |       |       |        | 13-1/8 | L    | 19    | 3     |            | 993155 |
| 12-3/4                   | R    | 21    | 3                        | 992116 |        |                                       |       |       |        | 13     | R    | 21    | 3     |            | 993146 |
|                          |      |       |                          |        |        |                                       |       |       |        | 13     | L    | 21    | 3     |            | 993156 |

**Drop-In Hub**  
Use XHS II® Hub Kit # 225 / 226  
USE Gearcase Adapter Ring supplied with propeller.  
Refer to Pages 55-57 for Details on Hub Kit Components.

**Drop-In Hub**  
Use XHS II® Hub Kit # 225 / 226  
USE Gearcase Adapter Ring supplied with propeller.  
Refer to Pages 55-57 for Details on Hub Kit Components.

| Boat Description/Length | MATCH<br>MICHIGAN   |      |       |       |            |        | BALLISTIC<br>MICHIGAN                 |      |       |                      |        |        |   |    |   |        |
|-------------------------|---------------------|------|-------|-------|------------|--------|---------------------------------------|------|-------|----------------------|--------|--------|---|----|---|--------|
|                         | ALUMINUM PROPELLERS |      |       |       |            |        | STAINLESS STEEL - B SERIES PROPELLERS |      |       |                      |        |        |   |    |   |        |
|                         | Dia.                | Rot. | Pitch | Bld # | OEM Part # | Part # | 3-BLADE BALLISTIC                     |      |       | 3-BLADE BALLISTIC XL |        |        |   |    |   |        |
| 24' & Up - AL           | 14                  | R    | 15    | 3     |            | 061020 | Dia.                                  | Rot. | Pitch | Bld #                | Part # |        |   |    |   |        |
| 20'-24' - AL, SK        | 14                  | R    | 17    | 3     |            | 061024 | 13-5/8                                | R    | 15    | 3                    | 933415 |        |   |    |   |        |
| 20'-24' - AL            | 14                  | R    | 18    | 3     |            | 061026 | 13-1/2                                | R    | 17    | 3                    | 933417 |        |   |    |   |        |
| 17'-19' - AL, SK        | 14                  | R    | 19    | 3     |            | 061028 |                                       |      |       |                      |        |        |   |    |   |        |
| 16'-18' - AL, SK        | 14                  | R    | 21    | 3     |            | 061032 | 13-3/8                                | R    | 19    | 3                    | 933419 |        |   |    |   |        |
| 15'-18' - AL, SK        |                     |      |       |       |            |        | 13-1/8                                | R    | 21    | 3                    | 933421 | 13-1/2 | R | 22 | 3 | 953422 |
|                         |                     |      |       |       |            |        |                                       |      |       |                      |        | 13-1/2 | R | 24 | 3 | 953424 |

**Rubber Hub Bushing**  
Part # 65-441

**Drop-In Hub**  
Use XHS II® Hub Kit # 225 / 226  
USE Gearcase Adapter Ring supplied with propeller.

**Note:** For 90 HP & 115 HP 4-Stroke engine applications use XHS II® (Drop-In Hub) Kit # 225.  
For 140 HP 4-Stroke engine applications use XHS II® (Drop-In Hub) Kit # 226.



061020



061028



**200 & 225 HORSEPOWER • JOHNSON • 4-3/4" GEARCASE**

Thru Hub Exhaust & 15 Tooth Spline • VORTEX® AND APOLLO® PROPELLER DIAMETERS ARE SLIGHTLY LESS THAN ORIGINAL EQUIPMENT PROPELLERS.

200 HP 4-Stroke .....2004-2005

225 HP 4-Stroke ..... 2004-2005

| VORTEX<br>MICHIGAN |      |       |       |        | 4-BL ALUMINUM - A SERIES |      |       |       |        |
|--------------------|------|-------|-------|--------|--------------------------|------|-------|-------|--------|
| Dia.               | Rot. | Pitch | Bld # | Part # | Dia.                     | Rot. | Pitch | Bld # | Part # |
| 16                 | R    | 13    | 3     | 992001 |                          |      |       |       |        |
| 15-1/4             | R    | 15    | 3     | 992002 |                          |      |       |       |        |
| 16                 | R    | 16    | 3     | 931516 |                          |      |       |       |        |
| 15                 | R    | 17    | 3     | 992003 | 15                       | R    | 16    | 4     | 992202 |
|                    |      |       |       |        |                          |      |       |       |        |
| 14-1/2             | R    | 19    | 3     | 992004 | 14-1/2                   | R    | 18    | 4     | 992203 |
|                    |      |       |       |        |                          |      |       |       |        |
| 14-1/4             | R    | 21    | 3     | 992005 | 14                       | R    | 20    | 4     | 992204 |
|                    |      |       |       |        |                          |      |       |       |        |
| 14                 | R    | 23    | 3     | 992006 |                          |      |       |       |        |

**Drop-In Hub**  
**Use XHS II® Hub Kit**  
**204**  
Refer to Pages 55-57 for Details on Hub Kit Components.

| APOLLO<br>MICHIGAN    |      |       |        |                          |      |       |        |                  |      |       |        |
|-----------------------|------|-------|--------|--------------------------|------|-------|--------|------------------|------|-------|--------|
| STD. 3-BLADE A SERIES |      |       |        | LG DIA. 3-BLADE A SERIES |      |       |        | 4-BLADE A SERIES |      |       |        |
| Dia.                  | Rot. | Pitch | Part # | Dia.                     | Rot. | Pitch | Part # | Dia.             | Rot. | Pitch | Part # |
| 14-3/8                | R    | 15    | 993042 |                          |      |       |        |                  |      |       |        |
| 14-3/8                | L    | 15    | 993052 |                          |      |       |        |                  |      |       |        |
| 14-1/4                | R    | 17    | 993043 | 15-1/2                   | R    | 17    | 993023 | 14-5/8           | R    | 16    | 993203 |
| 14-1/4                | L    | 17    | 993053 | 15-1/2                   | L    | 17    | 993033 | 14-5/8           | L    | 16    | 993213 |
| 14-1/8                | R    | 19    | 993044 | 15-1/4                   | R    | 19    | 993024 | 14-3/8           | R    | 18    | 993204 |
| 14-1/8                | L    | 19    | 993054 | 15-1/4                   | L    | 19    | 993034 | 14-3/8           | L    | 18    | 993214 |
| 14                    | R    | 21    | 993045 | 14-3/4                   | R    | 21    | 993025 | 14-1/8           | R    | 20    | 993205 |
| 14                    | L    | 21    | 993055 | 14-3/4                   | L    | 21    | 993035 | 14-1/8           | L    | 20    | 993215 |
| 13-7/8                | R    | 23    | 993046 | 14-5/8                   | R    | 23    | 993026 | 14               | R    | 22    | 993206 |
| 13-7/8                | L    | 23    | 993056 | 14-5/8                   | L    | 23    | 993036 | 14               | L    | 22    | 993216 |

**Drop-In Hub**  
**Use XHS II® Hub Kit**  
**204**  
Refer to Pages 55-57 for Details on Hub Kit Components.



| BALLISTIC<br>MICHIGAN                 |      |       |       |          |                      |      |       |       |          |
|---------------------------------------|------|-------|-------|----------|----------------------|------|-------|-------|----------|
| STAINLESS STEEL - A SERIES PROPELLERS |      |       |       |          |                      |      |       |       |          |
| 3-BLADE BALLISTIC                     |      |       |       |          | 3-BLADE BALLISTIC XL |      |       |       |          |
| Dia.                                  | Rot. | Pitch | Bld # | Part #   | Dia.                 | Rot. | Pitch | Bld # | Part #   |
| 14-7/8                                | R    | 15    | 3     | 933515   |                      |      |       |       |          |
| 14-3/4                                | R    | 17    | 3     | 933517   |                      |      |       |       |          |
| 14-3/4                                | L    | 17    | 3     | 937517   |                      |      |       |       |          |
| 14-1/2                                | R    | 19    | 3     | 933519   |                      |      |       |       |          |
| 14-1/2                                | L    | 19    | 3     | 937519   |                      |      |       |       |          |
| 14-3/8                                | R    | 21    | 3     | 933521   |                      |      |       |       |          |
| 14-3/8                                | L    | 21    | 3     | 937521   |                      |      |       |       |          |
| 14-1/4                                | R    | 23    | 3     | 933523   |                      |      |       |       |          |
| 14-1/4                                | L    | 23    | 3     | 937523   |                      |      |       |       |          |
| 14-1/4                                | R    | 25    | 3     | ※ 933525 |                      |      |       |       |          |
|                                       |      |       |       |          | 14-3/4               | R    | 22    | 3     | ※ 953522 |
|                                       |      |       |       |          | 14-3/4               | R    | 24    | 3     | ※ 953524 |
|                                       |      |       |       |          | 14-3/4               | R    | 26    | 3     | ※ 953526 |

**Drop-In Hub**  
**Use XHS II® Hub Kit**  
**204**  
Refer to Pages 55-57 for Details on Hub Kit Components.

※ May interfere with trim tab.





**90-300 HORSEPOWER • V-6 (4-3/4") GEARCASE (Includes E-TEC® & E-TEC® H.O. 25" Shaft Length)**  
Thru Hub Exhaust & 15 Tooth Spline

|  |              |
|--|--------------|
| 90 HP.....                             | 1995 & Newer |
| 90 HP E-TEC® (25" Shaft Length) ....   | 2004 & Newer |
| 100 HP Commercial.....                 | 1984 & Newer |
| 115 HP.....                            | 1995 & Newer |
| 115 HP E-TEC® (25" Shaft Length).....  | 2004 & Newer |
| 115 HP Pontoon Series.....             | 2014 & Newer |
| 120-140 HP.....                        | 1985         |
| 130 HP.....                            | 1995-1996    |
| 130 HP E-TEC® (25" Shaft Length) ..... | 2009-2010    |

|                               |              |
|-------------------------------|--------------|
| 135 HP.....                   | 2014 & Newer |
| 140 (25") HP .....            | 1989-1994    |
| 150 HP Commercial .....       | 1995 & Newer |
| 150 HP (Includes E-TEC®)..... | 1978 & Newer |
| 150 HP Pontoon Series.....    | 2014 & Newer |
| 155 HP Commercial .....       | 1978 & Newer |
| 175 HP (Includes E-TEC®)..... | 1977 & Newer |
| 185 HP .....                  | 1984-1985    |
| 200 HP (Includes E-TEC®)..... | 1976 & Newer |

|                               |                       |
|-------------------------------|-----------------------|
| 225 HP (Includes E-TEC®)..... | 1986 & Newer          |
| 235 HP .....                  | 1978-1985             |
| 250 HP (Includes E-TEC®)..... | 1991 & Newer          |
| 275 HP .....                  | 1986-1988             |
| 300 HP .....                  | 1988-1995; 09 & Newer |
| 2.6 Liter .....               | 1984-1985             |
| 3.6 Liter .....               | 1986-1987             |

**\*For engines 300 HP or higher, use "High Horsepower Sleeve" (P/N 991372). See Page 48 for more details.**

| VORTEX<br>MICHIGAN       |      |       |       |        |                          |      |       |       |        |
|--------------------------|------|-------|-------|--------|--------------------------|------|-------|-------|--------|
| 3-BL ALUMINUM - A SERIES |      |       |       |        | 4-BL ALUMINUM - A SERIES |      |       |       |        |
| Dia.                     | Rot. | Pitch | Bld # | Part # | Dia.                     | Rot. | Pitch | Bld # | Part # |
| 16                       | R    | 13    | 3     | 992001 |                          |      |       |       |        |
| 15-1/4                   | R    | 15    | 3     | 992002 |                          |      |       |       |        |
| 16                       | R    | 16    | 3     | 931516 |                          |      |       |       |        |
| 15                       | R    | 17    | 3     | 992003 | 15                       | R    | 16    | 4     | 992202 |
|                          |      |       |       |        |                          |      |       |       |        |
| 14-1/2                   | R    | 19    | 3     | 992004 | 14-1/2                   | R    | 18    | 4     | 992203 |
|                          |      |       |       |        |                          |      |       |       |        |
| 14-1/4                   | R    | 21    | 3     | 992005 | 14                       | R    | 20    | 4     | 992204 |
|                          |      |       |       |        |                          |      |       |       |        |
| 14                       | R    | 23    | 3     | 992006 |                          |      |       |       |        |

**Drop-In Hub**  
Use XHS II® Hub Kit **200 / 201**

Refer to Pages 55-57 for Details on Hub Kit Components.

| APOLLO<br>MICHIGAN    |      |       |        |                          |      |       |        |                  |      |       |        |
|-----------------------|------|-------|--------|--------------------------|------|-------|--------|------------------|------|-------|--------|
| STD. 3-BLADE A SERIES |      |       |        | LG DIA. 3-BLADE A SERIES |      |       |        | 4-BLADE A SERIES |      |       |        |
| Dia.                  | Rot. | Pitch | Part # | Dia.                     | Rot. | Pitch | Part # | Dia.             | Rot. | Pitch | Part # |
| 14-3/8                | R    | 15    | 993042 |                          |      |       |        |                  |      |       |        |
| 14-3/8                | L    | 15    | 993052 |                          |      |       |        |                  |      |       |        |
| 14-1/4                | R    | 17    | 993043 | 15-1/2                   | R    | 17    | 993023 | 14-5/8           | R    | 16    | 993203 |
| 14-1/4                | L    | 17    | 993053 | 15-1/2                   | L    | 17    | 993033 | 14-5/8           | L    | 16    | 993213 |
| 14-1/8                | R    | 19    | 993044 | 15-1/4                   | R    | 19    | 993024 | 14-3/8           | R    | 18    | 993204 |
| 14-1/8                | L    | 19    | 993054 | 15-1/4                   | L    | 19    | 993034 | 14-3/8           | L    | 18    | 993214 |
| 14                    | R    | 21    | 993045 | 14-3/4                   | R    | 21    | 993025 | 14-1/8           | R    | 20    | 993205 |
| 14                    | L    | 21    | 993055 | 14-3/4                   | L    | 21    | 993035 | 14-1/8           | L    | 20    | 993215 |
| 13-7/8                | R    | 23    | 993046 | 14-5/8                   | R    | 23    | 993026 | 14               | R    | 22    | 993206 |
| 13-7/8                | L    | 23    | 993056 | 14-5/8                   | L    | 23    | 993036 | 14               | L    | 22    | 993216 |

**Drop-In Hub**  
Use XHS II® Hub Kit **200 / 201**

Refer to Pages 55-57 for Details on Hub Kit Components.

| Boat Description/<br>Length | MATCH<br>MICHIGAN   |      |       |       |            |        |
|-----------------------------|---------------------|------|-------|-------|------------|--------|
|                             | ALUMINUM PROPELLERS |      |       |       |            |        |
|                             | Dia.                | Rot. | Pitch | Bld # | OEM Part # | Part # |
| CR, HB                      | 15-1/2              | R    | 13    | 3     | 763453     | 011016 |
| CR, HB                      | 15-1/2              | R    | 15    | 3     | 765186     | 011006 |
| 20'-26' - AL, SK            | 15                  | R    | 17    | 3     | 765187     | 011007 |
| 20'-26' - AL, SK            |                     |      |       |       |            |        |
| 18'-22' - AL, SK            | 14-1/2              | R    | 19    | 3     | 765188     | 011008 |
| 18'-22' - AL, SK            |                     |      |       |       |            |        |
| 17'-19' - AL, SK            | 14-1/4              | R    | 21    | 3     | 765189     | 011009 |
| 17'-19' - AL, SK            |                     |      |       |       |            |        |
| 15'-18' - AL, SK            |                     |      |       |       |            |        |
| 15'-18' - AL, SK            |                     |      |       |       |            |        |
| High Performance            |                     |      |       |       |            |        |
| High Performance            |                     |      |       |       |            |        |
| 50-62 MPH                   |                     |      |       |       |            |        |
| 55-67 MPH                   |                     |      |       |       |            |        |
| 60-72 MPH                   |                     |      |       |       |            |        |

**Rubber Hub Bushing**  
Part # 65-254

| BALLISTIC<br>MICHIGAN                 |      |       |       |        |                      |      |       |       |        |
|---------------------------------------|------|-------|-------|--------|----------------------|------|-------|-------|--------|
| STAINLESS STEEL - A SERIES PROPELLERS |      |       |       |        |                      |      |       |       |        |
| 3-BLADE BALLISTIC                     |      |       |       |        | 3-BLADE BALLISTIC XL |      |       |       |        |
| Dia.                                  | Rot. | Pitch | Bld # | Part # | Dia.                 | Rot. | Pitch | Bld # | Part # |
| 14-7/8                                | R    | 15    | 3     | 933515 |                      |      |       |       |        |
| 14-3/4                                | R    | 17    | 3     | 933517 |                      |      |       |       |        |
| 14-3/4                                | L    | 17    | 3     | 937517 |                      |      |       |       |        |
| 14-1/2                                | R    | 19    | 3     | 933519 |                      |      |       |       |        |
| 14-1/2                                | L    | 19    | 3     | 937519 |                      |      |       |       |        |
| 14-3/8                                | R    | 21    | 3     | 933521 |                      |      |       |       |        |
| 14-3/8                                | L    | 21    | 3     | 937521 |                      |      |       |       |        |
| 14-1/4                                | R    | 23    | 3     | 933523 |                      |      |       |       |        |
| 14-1/4                                | L    | 23    | 3     | 937523 | 14-3/4               | R    | 22    | 3     | 953522 |
| 14-1/4                                | R    | 25    | 3     | 933525 | 14-3/4               | R    | 24    | 3     | 953524 |
|                                       |      |       |       |        | 14-3/4               | R    | 26    | 3     | 953526 |
| 4-BLADE BALLISTIC XL                  |      |       |       |        |                      |      |       |       |        |
|                                       |      |       |       |        | 14-1/8               | R    | 23    | 4     | 963523 |
|                                       |      |       |       |        | 14-1/8               | R    | 25    | 4     | 963525 |
|                                       |      |       |       |        | 14-1/8               | R    | 27    | 4     | 963527 |

**Drop-In Hub**  
Use XHS II® Hub Kit **200 / 201**

Refer to Pages 55-57 for Details on Hub Kit Components.

**Note:** For engine applications 1976-1990 use XHS II® (Drop-In Hub) Kit #201.  
For engine applications 1991 & Newer use XHS II® (Drop-In Hub) Kit #200.

**3.5-8 HORSEPOWER**

Non-Thru Hub Exhaust & 9 Tooth / Pin Drive

|                      |                      |                      |
|----------------------|----------------------|----------------------|
| 3.5 HP.....1982-1984 | 5 HP.....1987-1998   | 7 HP.....1968-1988   |
| 4 HP.....1977-1987   | 6 HP.....1975-1981   | 7.5 HP.....1979-1984 |
| 4.4 HP.....1968-1988 | 6.6 HP.....1968-1988 | 8 HP.....1975-1978   |

| Boat Description/<br>Length | MATCH<br>MICHIGAN   |      |       |       |            |        |
|-----------------------------|---------------------|------|-------|-------|------------|--------|
|                             | ALUMINUM PROPELLERS |      |       |       |            |        |
|                             | Dia.                | Rot. | Pitch | Bld # | OEM Part # | Part # |
| Standard Replacement        | 7-1/4               | R    | 5-1/2 | 3     | 48-FP488   | 072123 |



072123

Rubber  
Hub  
Bushing  
Part # 65-220

**6-10 HORSEPOWER**

Non-Thru Hub Exhaust & 14 Tooth / Pin Drive

|                                |                          |                     |
|--------------------------------|--------------------------|---------------------|
| 6 & 10 HP Sailor.....1976-1977 | Sailor 180.....1979-1984 | Sailor 280.....1979 |
| Sailor 150.....1978            | Sailor 250.....1979-1984 |                     |

| Boat Description/<br>Length | MATCH<br>MICHIGAN   |      |       |       |            |        |
|-----------------------------|---------------------|------|-------|-------|------------|--------|
|                             | ALUMINUM PROPELLERS |      |       |       |            |        |
|                             | Dia.                | Rot. | Pitch | Bld # | OEM Part # | Part # |
| SB                          | 10-3/8              | R    | 10    | 3     | FP-278     | 072014 |



072014

Rubber  
Hub  
Bushing  
Part # 65-164

**9.9-15 HORSEPOWER**

Thru Hub Exhaust & 8 Tooth Spline

|                      |                     |
|----------------------|---------------------|
| 9.9 HP.....1996-1998 | 15 HP.....1996-1998 |
|----------------------|---------------------|

| Boat Description/<br>Length | MATCH<br>MICHIGAN   |      |        |       |              |        |
|-----------------------------|---------------------|------|--------|-------|--------------|--------|
|                             | ALUMINUM PROPELLERS |      |        |       |              |        |
|                             | Dia.                | Rot. | Pitch  | Bld # | OEM Part #   | Part # |
| 16'-20' - AL                | 9-1/4               | R    | 7      | 3     | 48-828152A12 | 032056 |
| 14'-20' - AL                | 9                   | R    | 8      | 3     | 48-828154A12 | 032053 |
| 14'-18' - AL                | 9                   | R    | 9      | 3     | 48-828156A12 | 032052 |
| 14'-16' - AL                | 9                   | R    | 10-1/2 | 3     | 48-828158A12 | 032050 |



032056

Rubber  
Hub  
Bushing  
Part # 65-429

**25 HORSEPOWER • 3" GEARCASE**

Thru Hub Exhaust & 10 Tooth Spline • **MUST use Gearcase Adapter Ring supplied with propeller.**

|                           |
|---------------------------|
| 25 HP 3 Cyl.....1995-1998 |
|---------------------------|

| Boat Description/<br>Length | VORTEX<br>MICHIGAN             |      |       |       |             |        |
|-----------------------------|--------------------------------|------|-------|-------|-------------|--------|
|                             | ALUMINUM - E SERIES PROPELLERS |      |       |       |             |        |
|                             | Dia.                           | Rot. | Pitch | Bld # | OEM Part #  | Part # |
|                             | 10-1/2                         | R    | 9     | 3     |             | 992501 |
|                             | 10-1/2                         | R    | 10    | 3     |             | 992502 |
| 15'-19' - AL                | 10-1/2                         | R    | 11    | 3     | 48-19638A40 | 992503 |
| 15'-17' - AL                | 10-1/8                         | R    | 12    | 3     |             | 992504 |
| 13'-15' - LL                | 10-1/8                         | R    | 13    | 3     | 48-19640A40 | 992505 |
| Up to 14' - LL              | 10-1/8                         | R    | 14    | 3     |             | 992506 |

Drop-In  
Hub  
Use XHS®  
or XHS II®  
Hub Kit  
**120**  
OR  
**220**

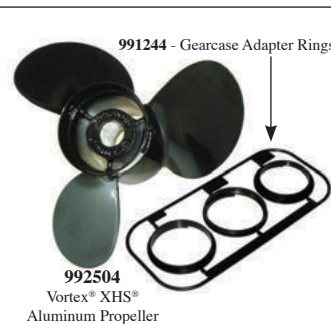

992504  
Vortex® XHS®  
Aluminum Propeller



031048

031049

| Boat Description/<br>Length | MATCH<br>MICHIGAN   |      |       |       |             |        |
|-----------------------------|---------------------|------|-------|-------|-------------|--------|
|                             | ALUMINUM PROPELLERS |      |       |       |             |        |
|                             | Dia.                | Rot. | Pitch | Bld # | OEM Part #  | Part # |
| 15'-19'                     | 10-3/8              | R    | 11    | 3     | 48-19638A40 | 031049 |
| 13'-15'                     | 10-3/8              | R    | 13    | 3     | 48-19640A40 | 031048 |
| Up to 14'                   |                     |      |       |       |             |        |

Rubber  
Hub  
Bushing  
Part # 65-308

| Boat Description/<br>Length | BALLISTIC<br>MICHIGAN                 |      |       |       |            |        |
|-----------------------------|---------------------------------------|------|-------|-------|------------|--------|
|                             | STAINLESS STEEL - E SERIES PROPELLERS |      |       |       |            |        |
|                             | Dia.                                  | Rot. | Pitch | Bld # | OEM Part # | Part # |
|                             | 10-1/8                                | R    | 13    | 3     |            | 933013 |
|                             | 10-1/8                                | R    | 15    | 3     |            | 933015 |

Drop-In  
Hub  
Use XHS®  
or XHS II®  
Hub Kit

**120**  
OR  
**220**

Note: \* May interfere with trim tab.

Key to Abbreviations: LL = Light Loads; SB = Sailboat; AL = All Loads; SK = Skiboat; WB = Workboat; HB = Houseboat; CR = Cruisers; HL = Heavy Loads; WD = Weedless

FORCE / CHRYSLER /  
US MARINE

## 20-60 HORSEPOWER

Non-Thru Hub Exhaust & 14 Tooth / Pin Drive • Will fit Sailor 6-10 HP engines, as required for RPM

|                        |                     |                        |
|------------------------|---------------------|------------------------|
| 20-25 HP.....1979-1981 | 40 HP.....1992-1994 | 55 HP ♦♦.....1966-1983 |
| 30 HP.....1966-1976    | 45 HP.....1966-1984 | 60 HP ♦♦.....1966-1975 |
| 35 HP.....1966-1991    | 50 HP.....1982-1994 |                        |

| Boat Description/<br>Length | MATCH<br>MICHIGAN   |      |        |       |              |        |
|-----------------------------|---------------------|------|--------|-------|--------------|--------|
|                             | ALUMINUM PROPELLERS |      |        |       |              |        |
|                             | Dia.                | Rot. | Pitch  | Bld # | OEM Part #   | Part # |
| CR, HB, SB                  | 10-3/8              | R    | 10     | 3     | 48-819337A40 | 072014 |
| 17'-19' - AL, SK            | 10-3/8              | R    | 11-1/2 | 3     | 48-819336A40 | 072131 |
| 16'-17' - AL, SK            | 10-3/8              | R    | 12-1/2 | 3     | 48-819335A40 | 072132 |
| 14'-16' - AL, SK            | 10-3/8              | R    | 13-1/2 | 3     | 48-819334A40 | 072133 |



072014

Rubber  
Hub  
Bushing  
Part # 65-164

FORCE / CHRYSLER /  
U.S. MARINE

## 40-75 HORSEPOWER • 3-1/4" GEARCASE

Thru Hub Exhaust & 13 Tooth Spline

|                     |                     |                     |
|---------------------|---------------------|---------------------|
| 40 HP.....1995-1998 | 70 HP.....1991-1995 | 75 HP.....1996-1998 |
| 50 HP.....1995-1998 |                     |                     |

| VORTEX<br>MICHIGAN             |      |       |        |                      |      |       |        |         |      |       |        |
|--------------------------------|------|-------|--------|----------------------|------|-------|--------|---------|------|-------|--------|
| ALUMINUM - D SERIES PROPELLERS |      |       |        |                      |      |       |        |         |      |       |        |
| 3-BLADE                        |      |       |        | LG. DIAMETER 3-BLADE |      |       |        | 4-BLADE |      |       |        |
| Dia.                           | Rot. | Pitch | Part # | Dia.                 | Rot. | Pitch | Part # | Dia.    | Rot. | Pitch | Part # |
|                                |      |       |        |                      |      |       |        | 11-1/2  | R    | 8     | 992401 |
|                                |      |       |        | 12-1/4               | R    | 9     | 992601 | 11-1/2  | R    | 9     | 992402 |
|                                |      |       |        | 11-3/4               | R    | 10    | 992602 | 11-1/2  | R    | 10    | 992403 |
| 10-3/8                         | R    | 11    | 992404 | 11-5/8               | R    | 11    | 992603 | 4-BLADE |      |       |        |
| 10-3/8                         | R    | 12    | 992405 | 11-3/8               | R    | 12    | 992604 | 10-5/8  | R    | 12    | 941212 |
| 10-3/8                         | R    | 13    | 992406 | 11-1/8               | R    | 13    | 992605 | 10-3/8  | R    | 13    | 941213 |
| 10-3/8                         | R    | 14    | 992407 | 11-1/4               | R    | 14    | 992606 | 10-1/8  | R    | 14    | 941214 |
| 10                             | R    | 15    | 992408 |                      |      |       |        | 10-1/8  | R    | 15    | 941215 |
| 10                             | R    | 16    | 992409 |                      |      |       |        |         |      |       |        |

Drop-In  
Hub  
Use XHS®  
or XHS II®  
Hub Kit  
**114**  
OR  
**214**  
Refer to  
Pages 55-57  
for Details  
on Hub Kit  
Components.

| APOLLO<br>MICHIGAN                    |      |       |       |            |        |  |  |  |  |  |  |
|---------------------------------------|------|-------|-------|------------|--------|--|--|--|--|--|--|
| STAINLESS STEEL - D SERIES PROPELLERS |      |       |       |            |        |  |  |  |  |  |  |
| Dia.                                  | Rot. | Pitch | Bld # | OEM Part # | Part # |  |  |  |  |  |  |
| 10-3/4                                | R    | 12    | 3     |            | 993405 |  |  |  |  |  |  |
| 10-1/2                                | R    | 13    | 3     |            | 993406 |  |  |  |  |  |  |
| 10-3/8                                | R    | 14    | 3     |            | 993407 |  |  |  |  |  |  |
| 10-1/8                                | R    | 15    | 3     |            | 993408 |  |  |  |  |  |  |

Drop-In  
Hub  
Use XHS®  
or XHS II®  
Hub Kit  
**114**  
OR  
**214**  
Refer to  
Pages 55-57  
for Details  
on Hub Kit  
Components.

| Boat Description/<br>Length | MATCH<br>MICHIGAN   |      |        |       |              |        |
|-----------------------------|---------------------|------|--------|-------|--------------|--------|
|                             | ALUMINUM PROPELLERS |      |        |       |              |        |
|                             | Dia.                | Rot. | Pitch  | Bld # | OEM Part #   | Part # |
| 19' & Up                    | 12-1/2              | R    | 8      | 3     | 48-42738A10  | 032141 |
| 19' & Up                    | 12-1/4              | R    | 9      | 3     |              | 032143 |
| 17'-19' - AL, SK            | 11-1/4              | R    | 10     | 3     | 48-73132A40  | 031015 |
| 16'-18' - AL, SK            | 12                  | R    | 10-1/2 | 3     | 48-42740A10  | 032142 |
| 16'-18' - AL, SK            | 10-7/8              | R    | 11     | 3     | 48-85632A40  | 031053 |
| 15'-17' - AL, SK            | 10-3/4              | R    | 12     | 3     | 48-816702A40 | 031056 |
| 15'-17' - AL, SK            | 10-5/8              | R    | 12     | 3     | 48-73134A40  | 031016 |
| 14'-17' - AL, SK            | 10-1/2              | R    | 13     | 3     | 48-816704A40 | 031057 |
| 14'-17' - AL, SK            | 10-3/8              | R    | 13     | 3     | 48-73136A40  | 031017 |
| 14'-16' - LL                | 10-3/8              | R    | 14     | 3     | 48-816706A40 | 031058 |
| 14'-16' - LL                | 10-1/4              | R    | 14     | 3     | 48-73138A40  | 031018 |
| 13'-15' - LL                | 10-1/8              | R    | 15     | 3     | 48-73140A40  | 031019 |
| Up to 15'                   | 10                  | R    | 17     | 3     | 48-73144A40  | 031020 |

Rubber  
Hub  
Bushing  
Part # 65-264

| BALLISTIC<br>MICHIGAN                 |      |       |       |            |        |  |  |  |  |  |  |
|---------------------------------------|------|-------|-------|------------|--------|--|--|--|--|--|--|
| STAINLESS STEEL - D SERIES PROPELLERS |      |       |       |            |        |  |  |  |  |  |  |
| Dia.                                  | Rot. | Pitch | Bld # | OEM Part # | Part # |  |  |  |  |  |  |
| 10-1/8                                | R    | 13    | 3     |            | 933213 |  |  |  |  |  |  |
| 10-1/8                                | R    | 15    | 3     |            | 933215 |  |  |  |  |  |  |

Drop-In  
Hub  
Use XHS®  
or XHS II®  
Hub Kit  
**114**  
OR  
**214**  
Refer to  
Pages 55-57  
for Details  
on Hub Kit  
Components.

Key to Abbreviations: LL = Light Loads; SB = Sailboat; AL = All Loads; SK = Skiboat; WB = Workboat; HB = Houseboat; CR = Cruisers; HL = Heavy Loads; WD = Weedless

♦♦ Two-piece lower unit.

## 75-140 HORSEPOWER • SINGLE EXHAUST UNITS ❖ (SEE BELOW)

Non-Thru Hub Exhaust & 15 Tooth Spline

|                            |           |                             |                       |              |           |
|----------------------------|-----------|-----------------------------|-----------------------|--------------|-----------|
| 75 HP Std. & Charger ..... | 1980-1984 | 105 HP .....                | 1977-1978; 1982       | 135 HP ..... | 1977      |
| 85 HP Std. & Charger ..... | 1978-1989 | 115 HP Std. & Charger ..... | 1978-1984             | 140 HP ..... | 1978-1984 |
| 90 HP .....                | 1983-1984 | 120 HP .....                | 1977                  |              |           |
| 100 HP .....               | 1979-1984 | 125 HP .....                | 1977; 1982; 1985-1989 |              |           |

| Boat Description/<br>Length | MATCH<br>MICHIGAN   |      |       |       |            |        |
|-----------------------------|---------------------|------|-------|-------|------------|--------|
|                             | ALUMINUM PROPELLERS |      |       |       |            |        |
|                             | Dia.                | Rot. | Pitch | Bld # | OEM Part # | Part # |
| 16'-17' - AL, SK            | 13-1/8              | R    | 15    | 3     | FPS519     | 072055 |
| 14'-16' - AL, SK            | 13-1/4              | R    | 17    | 3     | FPS623     | 072107 |
| 14'-16' - LL                | 13                  | R    | 19    | 3     | FPS625     | 072108 |



072055



072108

Rubber  
Hub  
Bushing  
Part # 65-376

## 85-150 HORSEPOWER • DUAL EXHAUST UNITS • 4-1/4" GEARCASE (SEE BELOW)

Thru Hub Exhaust & 15 Tooth Spline

|                    |           |                      |           |                      |           |
|--------------------|-----------|----------------------|-----------|----------------------|-----------|
| 85 HP .....        | 1988-1989 | 120 HP .....         | 1990-1994 | 150 HP .....         | 1989-1994 |
| 90 HP .....        | 1990-1994 | 120 HP L-Drive ..... | 1989-1991 | 150 HP L-Drive ..... | 1991      |
| 90 HPL-Drive ..... | 1989-1991 | 125 HP .....         | 1988-1989 |                      |           |

| VORTEX<br>MICHIGAN       |      |       |       |        | Drop-In<br>Hub           |      |       |       |        |
|--------------------------|------|-------|-------|--------|--------------------------|------|-------|-------|--------|
| 3-BL ALUMINUM - B SERIES |      |       |       |        | 4-BL ALUMINUM - B SERIES |      |       |       |        |
| Dia.                     | Rot. | Pitch | Bld # | Part # | Dia.                     | Rot. | Pitch | Bld # | Part # |
| 14                       | R    | 10    | 3     | 992109 |                          |      |       |       |        |
| 14                       | R    | 11    | 3     | 992111 | 13-7/8                   | R    | 11    | 4     | 941411 |
| 14                       | R    | 13    | 3     | 992112 | 13-7/8                   | R    | 13    | 4     | 941413 |
| 13-3/4                   | R    | 15    | 3     | 992113 | 13-3/8                   | R    | 15    | 4     | 941415 |
| 13-1/4                   | R    | 17    | 3     | 992114 | 13                       | R    | 17    | 4     | 941417 |
| 13                       | R    | 19    | 3     | 992115 | 12-1/2                   | R    | 19    | 4     | 941419 |
| 12-3/4                   | R    | 21    | 3     | 992116 |                          |      |       |       |        |

Drop-In  
Hub

Use XHS  
II®  
Hub Kit

202

Do NOT use  
Gearcase  
Adapter Ring  
supplied with  
propeller.



941417



071036



072128



072127

| Boat<br>Description/<br>Length | MATCH<br>MICHIGAN   |      |       |       |            |          |
|--------------------------------|---------------------|------|-------|-------|------------|----------|
|                                | ALUMINUM PROPELLERS |      |       |       |            |          |
|                                | Dia.                | Rot. | Pitch | Bld # | OEM Part # | Part #   |
| 17'-22' - AL, SK               | 13-1/2              | R    | 15    | 3     | 48-FP669-1 | * 071035 |
| 17'-22' - AL, SK               | 13-1/2              | R    | 15    | 3     | 48-FP692-1 | 072127   |
| 16'-20' - AL, SK               | 13-1/2              | R    | 17    | 3     | 48-FP685-1 | * 071036 |
| 16'-20' - AL, SK               | 13-1/2              | R    | 17    | 3     | 48-FP685-1 | 072128   |

Rubber  
Hub  
Bushing  
Part # 65-262

### Single vs. Dual Exhaust

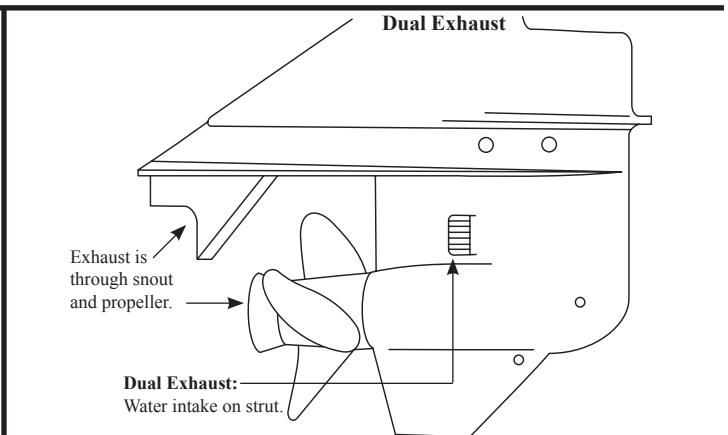
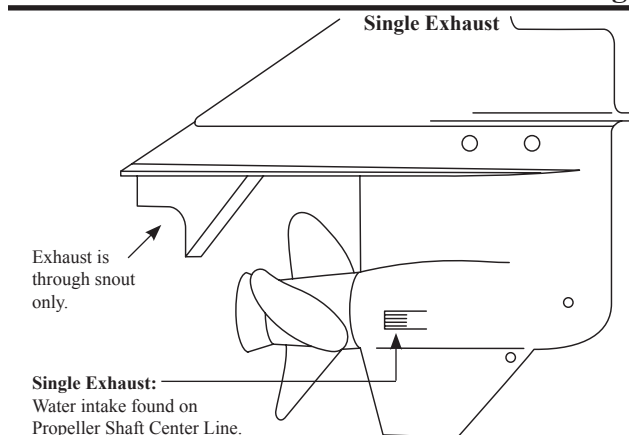

Key to Abbreviations: LL = Light Loads; SB = Sailboat; AL = All Loads; SK = Skiboat; WB = Workboat; HB = Houseboat; CR = Cruisers; HL = Heavy Loads; WD = Weedless

\* If currently using uncupped propeller, use cupped propeller having 2" less pitch. Boats with power trim use same pitch.

## 75-150 HORSEPOWER • USING MERCURY 4-1/4" GEARCASE (SEE BELOW)

Thru Hub Exhaust & 15 Tooth Spline

75 HP .....1999  
 90 HP .....1995 & Newer  
 90 HP L-Drive.....1990-1991

120 HP .....1995 & Newer  
 120 HP L-Drive.....1990-1991

150 HP .....1989-1994  
 150 HP L-Drive .....1991

| VORTEX<br>—MICHIGAN—     |      |       |                          |        |                      |
|--------------------------|------|-------|--------------------------|--------|----------------------|
| 3-BL ALUMINUM - B SERIES |      |       | 4-BL ALUMINUM - B SERIES |        |                      |
| Dia.                     | Rot. | Pitch | Bld #                    | Part # |                      |
| 14                       | R    | 10    | 3                        | 992109 |                      |
| 14                       | R    | 11    | 3                        | 992111 | 13-7/8 R 11 4 941411 |
| 14                       | R    | 13    | 3                        | 992112 | 13-7/8 R 13 4 941413 |
| 13-3/4                   | R    | 15    | 3                        | 992113 | 13-3/8 R 15 4 941415 |
| 13-1/4                   | R    | 17    | 3                        | 992114 | 13 R 17 4 941417     |
| 13                       | R    | 19    | 3                        | 992115 | 12-1/2 R 19 4 941419 |
| 12-3/4                   | R    | 21    | 3                        | 992116 |                      |

Drop-In Hub

Use XHS II® Hub Kit

**202**

USE Gearcase Adapter Ring supplied with propeller.

Refer to Pages 55-57 for Details on Hub Kit Components.

| APOLLO<br>—MICHIGAN—                  |      |       |       |            |        |
|---------------------------------------|------|-------|-------|------------|--------|
| STAINLESS STEEL - B SERIES PROPELLERS |      |       |       |            |        |
| Dia.                                  | Rot. | Pitch | Bld # | OEM Part # | Part # |
| 13-3/8                                | R    | 15    | 3     |            | 993143 |
| 13-3/8                                | L    | 15    | 3     |            | 993153 |
| 13-1/4                                | R    | 17    | 3     |            | 993144 |
| 13-1/4                                | L    | 17    | 3     |            | 993154 |
| 13-1/8                                | R    | 19    | 3     |            | 993145 |
| 13-1/8                                | L    | 19    | 3     |            | 993155 |
| 13                                    | R    | 21    | 3     |            | 993146 |
| 13                                    | L    | 21    | 3     |            | 993156 |

Drop-In Hub

Use XHS II® Hub Kit

**202**

USE Gearcase Adapter Ring supplied with propeller.

Refer to Pages 55-57 for Details on Hub Kit Components.

| Boat Description/<br>Length | MATCH<br>—MICHIGAN— |      |       |       |             |        |
|-----------------------------|---------------------|------|-------|-------|-------------|--------|
|                             | ALUMINUM PROPELLERS |      |       |       |             |        |
|                             | Dia.                | Rot. | Pitch | Bld # | OEM Part #  | Part # |
| 25' & Up - AL               | 14                  | R    | 10    | 3     |             | 031061 |
| 25' & Up                    | 14                  | R    | 11    | 3     | 48-77338A45 | 031254 |
| 22' & Up                    | 14                  | R    | 13    | 3     | 48-77340A45 | 031055 |
| 19'-24' - AL                | 13-1/2              | R    | 15    | 3     | 48-77342A45 | 031041 |
| 17'-20' - AL, SK            | 13-1/4              | R    | 17    | 3     | 48-77344A45 | 031042 |
| 16'-19' - AL                | 13                  | R    | 19    | 3     | 48-77346A45 | 031043 |
| 15'-18' - AL                | 12-3/4              | R    | 21    | 3     | 48-77348A45 | 031044 |

Rubber Hub Bushing  
Part # 65-444

| BALLISTIC<br>—MICHIGAN—               |      |       |       |        |                      |      |       |       |          |
|---------------------------------------|------|-------|-------|--------|----------------------|------|-------|-------|----------|
| STAINLESS STEEL - B SERIES PROPELLERS |      |       |       |        |                      |      |       |       |          |
| 3-BLADE BALLISTIC                     |      |       |       |        | 3-BLADE BALLISTIC XL |      |       |       |          |
| Dia.                                  | Rot. | Pitch | Bld # | Part # | Dia.                 | Rot. | Pitch | Bld # | Part #   |
| 13-5/8                                | R    | 15    | 3     | 933415 |                      |      |       |       |          |
| 13-1/2                                | R    | 17    | 3     | 933417 |                      |      |       |       |          |
| 13-3/8                                | R    | 19    | 3     | 933419 |                      |      |       |       |          |
| 13-1/8                                | R    | 21    | 3     | 933421 | 13-1/2               | R    | 22    | 3     | * 953422 |
|                                       |      |       |       |        | 13-1/2               | R    | 24    | 3     | * 953424 |

Drop-In Hub

Use XHS II® Hub Kit

**202**

USE Gearcase Adapter Ring supplied with propeller.

Refer to Pages 55-57 for Details on Hub Kit Components.

Note: \* Requires Michigan Wheel high performance trim tab P/N 990404.



031042



031043



990404



### Force Using Mercury Gearcase

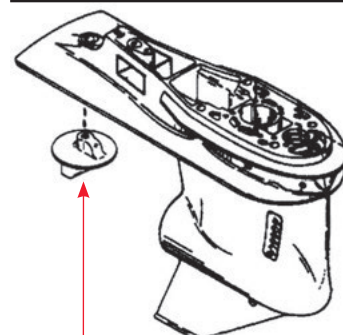

Exhaust is through propeller only. No exhaust snout, trim tab only.

**7.5-10 HORSEPOWER**  
Non-Thru Hub Exhaust & Pin Drive

BF 7.5.....1978-1987 BF 8..... 1987-1999 BF 100 (10 HP) .....All Years

| Boat Description/<br>Length | MATCH<br>MICHIGAN   |      |       |       |                 |        |
|-----------------------------|---------------------|------|-------|-------|-----------------|--------|
|                             | ALUMINUM PROPELLERS |      |       |       |                 |        |
|                             | Dia.                | Rot. | Pitch | Bld # | OEM Part #      | Part # |
| 16' & Up - LL               | 9-1/4               | R    | 7     | 3     |                 | 012102 |
| 14'-16' - LL                | 9                   | R    | 9     | 3     | 58130-881-840ZA | 012109 |
| 12'-14' - LL                | 9                   | R    | 10    | 3     |                 | 012011 |
| 12'-14' - LL                | 9-1/4               | R    | 11    | 3     |                 | 012013 |



Rubber  
Hub  
Bushing  
Part # 65-079

**8-20 HORSEPOWER • 2-1/2" GEARCASE**

Thru Hub Exhaust & 8 Tooth Spline

BF 8.....2000 & Newer BF 15.....1991 & Newer BF 20.....2003 & Newer  
BF 9.9.....1988 & Newer

| Boat Description/<br>Length | MATCH<br>MICHIGAN   |      |        |       |                 |        |
|-----------------------------|---------------------|------|--------|-------|-----------------|--------|
|                             | ALUMINUM PROPELLERS |      |        |       |                 |        |
|                             | Dia.                | Rot. | Pitch  | Bld # | OEM Part #      | Part # |
| 15'-17' - AL                | 9-1/4               | R    | 8      | 3     | 58130-ZV4-008AH | 102003 |
| 14'-16' - AL                | 9-1/4               | R    | 9      | 3     | 58130-ZV4-009AH | 102004 |
| 14'-16' - AL                | 9-1/4               | R    | 9-3/4  | 3     |                 | 102106 |
| Up to 15' - LL              | 9-1/4               | R    | 10-1/2 | 3     | 58130-ZV4-010AH | 102005 |
| Up to 15' - LL              | 9-1/4               | R    | 12     | 3     |                 | 102107 |



Rubber  
Hub  
Bushing  
Part # 65-359

Refer to  
Pages 53-54  
for Details  
on Attachment  
Hardware  
Components.

**25-30 HORSEPOWER • 3" GEARCASE**

Thru Hub Exhaust & 10 Tooth Spline • **! MUST use Gearcase Adapter Ring supplied with propeller.**

BF 25.....1994 & Newer BF 30.....1995 & Newer

| Boat Description/<br>Length | VORTEX<br>MICHIGAN             |      |       |       |             |        |
|-----------------------------|--------------------------------|------|-------|-------|-------------|--------|
|                             | ALUMINUM - E SERIES PROPELLERS |      |       |       |             |        |
|                             | Dia.                           | Rot. | Pitch | Bld # | OEM Part #  | Part # |
| 20' & Up                    | 10-1/2                         | R    | 9     | 3     |             | 992501 |
| 20' & Up                    | 10-1/2                         | R    | 10    | 3     |             | 992502 |
| 17'-20' - AL                | 10-1/2                         | R    | 11    | 3     | 48-19638A40 | 992503 |
| 15'-18' - AL                | 10-1/8                         | R    | 12    | 3     |             | 992504 |
| 13'-15' - LL                | 10-1/8                         | R    | 13    | 3     | 48-19640A40 | 992505 |
| 13'-15' - LL                | 10-1/8                         | R    | 14    | 3     |             | 992506 |

Drop-In  
Hub  
Use XHS®  
or XHS II®  
Hub Kit  
**119**  
OR  
**219**

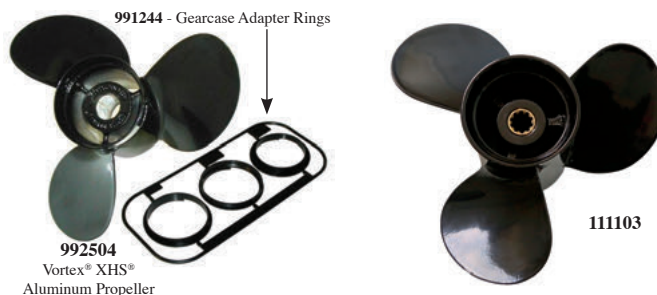

| Boat Description/<br>Length | MATCH<br>MICHIGAN   |      |       |       |                 |        |
|-----------------------------|---------------------|------|-------|-------|-----------------|--------|
|                             | ALUMINUM PROPELLERS |      |       |       |                 |        |
|                             | Dia.                | Rot. | Pitch | Bld # | OEM Part #      | Part # |
| 20' & Up                    | 9-7/8               | R    | 9     | 3     | 58130-ZW2-F11AZ | 111103 |
| 18'-20' - AL                | 9-7/8               | R    | 10    | 3     | 58130-ZW2-F21ZA | 111107 |
| 17'-20' - AL                | 9-7/8               | R    | 11    | 3     | 58130-ZW2-F31ZA | 111105 |
| 15'-18' - AL                | 9-7/8               | R    | 12    | 3     | 58130-ZW2-F01ZA | 111106 |
| 13'-15' - LL                | 9-7/8               | R    | 13    | 3     | 58130-ZW2-F41AZ | 111108 |
| Up to 15' - LL              |                     |      |       |       |                 |        |

Rubber  
Hub  
Bushing  
Part # 65-448  
Refer to  
Pages 53-54  
for Details  
on Attachment  
Hardware  
Components.

| Boat Description/<br>Length | BALLISTIC<br>MICHIGAN                 |      |       |       |            |        |
|-----------------------------|---------------------------------------|------|-------|-------|------------|--------|
|                             | STAINLESS STEEL - E SERIES PROPELLERS |      |       |       |            |        |
|                             | Dia.                                  | Rot. | Pitch | Bld # | OEM Part # | Part # |
|                             |                                       |      |       |       |            |        |
|                             |                                       |      |       |       |            |        |
|                             |                                       |      |       |       |            |        |
|                             | 10-1/8                                | R    | 13    | 3     |            | 933013 |
|                             | 10-1/8                                | R    | 15    | 3     |            | 933015 |

Drop-In  
Hub  
Use XHS®  
or XHS II®  
Hub Kit  
**119**  
OR  
**219**

Note: \* May interfere with trim tab.

**35-60 HORSEPOWER • 3-1/4" GEARCASE**

Thru Hub Exhaust & 13 Tooth Spline

|                        |                               |                               |
|------------------------|-------------------------------|-------------------------------|
| BF 35.....1991-1994    | BF 45.....1991-1994           | BF 60 / 60A .....2010 & Newer |
| BF 40.....1995 & Newer | BF 50 / 50A .....1995 & Newer |                               |

| <b>VORTEX</b><br>MICHIGAN      |      |       |        |                      |      |       |        |                |      |       |        |
|--------------------------------|------|-------|--------|----------------------|------|-------|--------|----------------|------|-------|--------|
| ALUMINUM - D SERIES PROPELLERS |      |       |        |                      |      |       |        |                |      |       |        |
| 3-BLADE                        |      |       |        | LG. DIAMETER 3-BLADE |      |       |        | 4-BLADE        |      |       |        |
| Dia.                           | Rot. | Pitch | Part # | Dia.                 | Rot. | Pitch | Part # | Dia.           | Rot. | Pitch | Part # |
|                                |      |       |        |                      |      |       |        | 11-1/2         | R    | 8     | 992401 |
|                                |      |       |        | 12-1/4               | R    | 9     | 992601 | 11-1/2         | R    | 9     | 992402 |
|                                |      |       |        | 11-3/4               | R    | 10    | 992602 | 11-1/2         | R    | 10    | 992403 |
| 10-3/8                         | R    | 11    | 992404 | 11-5/8               | R    | 11    | 992603 | <b>4-BLADE</b> |      |       |        |
| 10-3/8                         | R    | 12    | 992405 | 11-3/8               | R    | 12    | 992604 | 10-5/8         | R    | 12    | 941212 |
| 10-3/8                         | R    | 13    | 992406 | 11-1/8               | R    | 13    | 992605 | 10-3/8         | R    | 13    | 941213 |
| 10-3/8                         | R    | 14    | 992407 | 11-1/4               | R    | 14    | 992606 | 10-1/8         | R    | 14    | 941214 |
| 10                             | R    | 15    | 992408 |                      |      |       |        | 10-1/8         | R    | 15    | 941215 |
| 10                             | R    | 16    | 992409 |                      |      |       |        |                |      |       |        |

**Drop-In Hub**

Use XHS® or XHS II® Hub Kit

**113 OR 213**

Refer to Pages 55-57 for Details on Hub Kit Components.

| <b>APOLLO</b><br>MICHIGAN             |      |       |       |                               |      |       |       |            |        |  |  |
|---------------------------------------|------|-------|-------|-------------------------------|------|-------|-------|------------|--------|--|--|
| STAINLESS STEEL - D SERIES PROPELLERS |      |       |       |                               |      |       |       |            |        |  |  |
|                                       |      |       |       | Nearest Equivalent OEM Part # |      |       |       | Part #     |        |  |  |
| Dia.                                  | Rot. | Pitch | Bld # | Dia.                          | Rot. | Pitch | Bld # | OEM Part # | Part # |  |  |
| 10-3/4                                | R    | 12    | 3     | 59133-ZV5-012AH               |      |       |       |            | 993405 |  |  |
| 10-1/2                                | R    | 13    | 3     | 59133-ZV5-013AH               |      |       |       |            | 993406 |  |  |
| 10-3/8                                | R    | 14    | 3     | 59133-ZV5-014AH               |      |       |       |            | 993407 |  |  |
| 10-1/8                                | R    | 15    | 3     | 59133-ZV5-015AH               |      |       |       |            | 993408 |  |  |

**Drop-In Hub**

Use XHS® or XHS II® Hub Kit

**113 OR 213**

Refer to Pages 55-57 for Details on Hub Kit Components.

| <b>MATCH</b><br>MICHIGAN |        |      |       |       |                 |        |  |  |  |  |  |
|--------------------------|--------|------|-------|-------|-----------------|--------|--|--|--|--|--|
| ALUMINUM PROPELLERS      |        |      |       |       |                 |        |  |  |  |  |  |
| Boat Description/Length  | Dia.   | Rot. | Pitch | Bld # | OEM Part #      | Part # |  |  |  |  |  |
| Pontoon                  | 12-1/4 | R    | 9     | 3     | 59130-ZV5-009AH | 032046 |  |  |  |  |  |
| 17' & Up - AL, SK        | 11-3/4 | R    | 10    | 3     | 59130-ZV5-860ZA | 032045 |  |  |  |  |  |
| 16'-18' - AL, SK         | 11-5/8 | R    | 11    | 3     | 59130-ZV5-011AH | 032044 |  |  |  |  |  |
| 15'-17' - CUPPED         | 10-5/8 | R    | 12    | 3     |                 | 031074 |  |  |  |  |  |
| 15'-17' - AL, SK         | 11-3/8 | R    | 12    | 3     | 59130-ZV5-012AH | 032043 |  |  |  |  |  |
| 14'-17' - CUPPED         | 10-3/8 | R    | 13    | 3     |                 | 031075 |  |  |  |  |  |
| 14'-17' - AL, SK         | 11-1/8 | R    | 13    | 3     | 59130-ZV5-013AH | 032042 |  |  |  |  |  |
| 14'-16' - CUPPED         | 10-1/4 | R    | 14    | 3     |                 | 031076 |  |  |  |  |  |
| 14'-16' - AL, SK         | 11-1/4 | R    | 14    | 3     | 59130-ZV5-014AH | 032041 |  |  |  |  |  |
| 13'-15' - AL, SK         | 11     | R    | 15    | 3     | 59130-ZV5-015AH | 032040 |  |  |  |  |  |

**Rubber Hub Bushing**

Part # 65-205

Refer to Pages 53-54 for Details on Attachment Hardware Components.

| <b>BALLISTIC</b><br>MICHIGAN          |      |       |       |            |        |  |  |  |  |  |  |
|---------------------------------------|------|-------|-------|------------|--------|--|--|--|--|--|--|
| STAINLESS STEEL - D SERIES PROPELLERS |      |       |       |            |        |  |  |  |  |  |  |
| Dia.                                  | Rot. | Pitch | Bld # | OEM Part # | Part # |  |  |  |  |  |  |
| 10-1/8                                | R    | 13    | 3     |            | 933213 |  |  |  |  |  |  |
| 10-1/8                                | R    | 15    | 3     |            | 933215 |  |  |  |  |  |  |

**Drop-In Hub**

Use XHS® or XHS II® Hub Kit

**113 OR 213**

Refer to Pages 55-57 for Details on Hub Kit Components.

HONDA



032046



031074



**60-130 HORSEPOWER • 4-1/4" GEARCASE**

Thru Hub Exhaust & 15 Tooth Spline

|                         |                         |                      |
|-------------------------|-------------------------|----------------------|
| BFP 60.....2010 & Newer | BF 90.....1995 & Newer  | BF 115.....1998-2010 |
| BF 75.....1995 & Newer  | BF 100.....2016 & Newer | BF 130.....1998-2004 |

| VORTEX<br>MICHIGAN       |      |       |                          |        |                      |
|--------------------------|------|-------|--------------------------|--------|----------------------|
| 3-BL ALUMINUM - B SERIES |      |       | 4-BL ALUMINUM - B SERIES |        |                      |
| Dia.                     | Rot. | Pitch | Bld #                    | Part # |                      |
| 14                       | R    | 10    | 3                        | 992109 |                      |
| 14                       | R    | 11    | 3                        | 992111 | 13-7/8 R 11 4 941411 |
| 14                       | R    | 13    | 3                        | 992112 | 13-7/8 R 13 4 941413 |
| 13-3/4                   | R    | 15    | 3                        | 992113 | 13-3/8 R 15 4 941415 |
| 13-1/4                   | R    | 17    | 3                        | 992114 | 13 R 17 4 941417     |
| 13                       | R    | 19    | 3                        | 992115 | 12-1/2 R 19 4 941419 |
| 12-3/4                   | R    | 21    | 3                        | 992116 |                      |

**Drop-In Hub**  
Use XHS II® Hub Kit **202 / 207**  
USE Gearcase Adapter Ring supplied with propeller.  
Refer to Pages 55-57 for Details on Hub Kit Components.

| APOLLO<br>MICHIGAN                    |      |       |       |                |        |
|---------------------------------------|------|-------|-------|----------------|--------|
| STAINLESS STEEL - B SERIES PROPELLERS |      |       |       |                |        |
| Dia.                                  | Rot. | Pitch | Bld # | OEM Part #     | Part # |
| 13-3/8                                | R    | 15    | 3     | 58133-ZW1-A15P | 993143 |
| 13-3/8                                | L    | 15    | 3     |                | 993153 |
| 13-1/4                                | R    | 17    | 3     |                | 993144 |
| 13-1/4                                | L    | 17    | 3     |                | 993154 |
| 13-1/8                                | R    | 19    | 3     |                | 993145 |
| 13-1/8                                | L    | 19    | 3     |                | 993155 |
| 13                                    | R    | 21    | 3     |                | 993146 |
| 13                                    | L    | 21    | 3     |                | 993156 |

**Drop-In Hub**  
Use XHS II® Hub Kit **202 / 207**  
USE Gearcase Adapter Ring supplied with propeller.  
Refer to Pages 55-57 for Details on Hub Kit Components.

| Boat Description/Length | MATCH<br>MICHIGAN   |      |       |       |                 |          |
|-------------------------|---------------------|------|-------|-------|-----------------|----------|
|                         | ALUMINUM PROPELLERS |      |       |       |                 |          |
|                         | Dia.                | Rot. | Pitch | Bld # | OEM Part #      | Part #   |
| 25' & Up - AL           | 14                  | R    | 10    | 3     |                 | 031061   |
| 25' & Up                | 14                  | R    | 11    | 3     | 58130-ZW1-011AH | 031254   |
| 22' & Up                | 14                  | R    | 13    | 3     | 58130-ZW1-013AH | 031055   |
| 19'-24' - AL            | 13-3/4              | R    | 15    | 3     | 58130-ZW1-015AH | 031041   |
| 17'-20' - AL, SK        | 13-1/4              | R    | 17    | 3     | 58130-ZW1-017AH | 031042   |
| 16'-19' - AL            | 13                  | R    | 19    | 3     | 58130-ZW1-019AH | 031043   |
| 15'-18' - AL            | 12-3/4              | R    | 21    | 3     | 58130-ZW1-021AH | 031044   |
| Up to 17' - LL          | 12-1/2              | R    | 23    | 3     | 58130-ZW1-W512A | Ⓢ 031045 |

**Rubber Hub Bushing**  
Part # 65-444  
Refer to Pages 53-54 for Details on Attachment Hardware Components.

| BALLISTIC<br>MICHIGAN                 |      |       |       |          |                      |      |       |       |          |
|---------------------------------------|------|-------|-------|----------|----------------------|------|-------|-------|----------|
| STAINLESS STEEL - B SERIES PROPELLERS |      |       |       |          |                      |      |       |       |          |
| 3-BLADE BALLISTIC                     |      |       |       |          | 3-BLADE BALLISTIC XL |      |       |       |          |
| Dia.                                  | Rot. | Pitch | Bld # | Part #   | Dia.                 | Rot. | Pitch | Bld # | Part #   |
| 13-5/8                                | R    | 15    | 3     | Ⓢ 933415 |                      |      |       |       |          |
| 13-1/2                                | R    | 17    | 3     | Ⓢ 933417 |                      |      |       |       |          |
| 13-3/8                                | R    | 19    | 3     | Ⓢ 933419 |                      |      |       |       |          |
| 13-1/8                                | R    | 21    | 3     | Ⓢ 933421 | 13-1/2               | R    | 22    | 3     | Ⓢ 953422 |
|                                       |      |       |       |          | 13-1/2               | R    | 24    | 3     | Ⓢ 953424 |

**Drop-In Hub**  
Use XHS II® Hub Kit **202 / 207**  
USE Gearcase Adapter Ring supplied with propeller.  
Refer to Pages 55-57 for Details on Hub Kit Components.

Ⓢ May interfere with trim tab.

**Note:** For BF 75 & BF 90 HP 1995-1998 engine applications use XHS II® (Drop-In Hub) Kit #202.  
For BF 75 & BF 90 HP 1999 & Newer engine applications use XHS II® (Drop-In Hub) Kit #207.  
For BFP 60, BF 115 & BF 130 HP 1998 & Newer engine applications use XHS II® (Drop-In Hub) Kit #207.



031042



031043





**115-250 HORSEPOWER • 4-3/4" GEARCASE**

Thru Hub Exhaust & 15 Tooth Spline

BF 115.....2011 & Newer  
BF 135.....2004 & Newer

BF 150.....2004 & Newer  
BF 200.....2002 & Newer

BF 225.....2002 & Newer  
BF 250.....2012 & Newer

**VORTEX**  
MICHIGAN

**APOLLO**  
MICHIGAN

| 3-BL ALUMINUM - A SERIES |      |       |       |        | 4-BL ALUMINUM - A SERIES |      |       |       |        |
|--------------------------|------|-------|-------|--------|--------------------------|------|-------|-------|--------|
| Dia.                     | Rot. | Pitch | Bld # | Part # | Dia.                     | Rot. | Pitch | Bld # | Part # |
| 16                       | R    | 13    | 3     | 992001 |                          |      |       |       |        |
| 15-1/4                   | R    | 15    | 3     | 992002 |                          |      |       |       |        |
| 16                       | R    | 16    | 3     | 931516 |                          |      |       |       |        |
| 15                       | R    | 17    | 3     | 992003 | 15                       | R    | 16    | 4     | 992202 |
|                          |      |       |       |        |                          |      |       |       |        |
| 14-1/2                   | R    | 19    | 3     | 992004 | 14-1/2                   | R    | 18    | 4     | 992203 |
|                          |      |       |       |        |                          |      |       |       |        |
| 14-1/4                   | R    | 21    | 3     | 992005 | 14                       | R    | 20    | 4     | 992204 |
|                          |      |       |       |        |                          |      |       |       |        |
| 14                       | R    | 23    | 3     | 992006 |                          |      |       |       |        |

**Drop-In Hub**  
**Use XHS II® Hub Kit**  
**207**  
Refer to Pages 55-57 for Details on Hub Kit Components.

| STD. 3-BLADE A SERIES |      |       |        | LG DIA. 3-BLADE A SERIES |      |       |        | 4-BLADE A SERIES |      |       |        |
|-----------------------|------|-------|--------|--------------------------|------|-------|--------|------------------|------|-------|--------|
| Dia.                  | Rot. | Pitch | Part # | Dia.                     | Rot. | Pitch | Part # | Dia.             | Rot. | Pitch | Part # |
| 14-3/8                | R    | 15    | 993042 |                          |      |       |        |                  |      |       |        |
| 14-3/8                | L    | 15    | 993052 |                          |      |       |        |                  |      |       |        |
| 14-1/4                | R    | 17    | 993043 | 15-1/2                   | R    | 17    | 993023 | 14-5/8           | R    | 16    | 993203 |
| 14-1/4                | L    | 17    | 993053 | 15-1/2                   | L    | 17    | 993033 | 14-5/8           | L    | 16    | 993213 |
| 14-1/8                | R    | 19    | 993044 | 15-1/4                   | R    | 19    | 993024 | 14-3/8           | R    | 18    | 993204 |
| 14-1/8                | L    | 19    | 993054 | 15-1/4                   | L    | 19    | 993034 | 14-3/8           | L    | 18    | 993214 |
| 14                    | R    | 21    | 993045 | 14-3/4                   | R    | 21    | 993025 | 14-1/8           | R    | 20    | 993205 |
| 14                    | L    | 21    | 993055 | 14-3/4                   | L    | 21    | 993035 | 14-1/8           | L    | 20    | 993215 |
| 13-7/8                | R    | 23    | 993046 | 14-5/8                   | R    | 23    | 993026 | 14               | R    | 22    | 993206 |
| 13-7/8                | L    | 23    | 993056 | 14-5/8                   | L    | 23    | 993036 | 14               | L    | 22    | 993216 |

**Drop-In Hub**  
**Use XHS II® Hub Kit**  
**207**  
Refer to Pages 55-57 for Details on Hub Kit Components.

**MATCH**  
MICHIGAN

**BALLISTIC**  
MICHIGAN

| Boat Description/<br>Length | ALUMINUM PROPELLERS |      |       |       |                |        |
|-----------------------------|---------------------|------|-------|-------|----------------|--------|
|                             | Dia.                | Rot. | Pitch | Bld # | OEM Part #     | Part # |
| CR, HB                      | 16                  | R    | 13    | 3     | 58130-ZY3-013A | 031513 |
| 21'-24' - AL                | 15-1/4              | R    | 15    | 3     | 58130-ZY3-015A | 031023 |
| 20'-23' - AL, SK            | 16                  | R    | 16    | 3     |                | 031516 |
| 19'-23' - AL, SK            | 14-1/2              | R    | 17    | 3     |                | 031024 |
| 19'-23' - AL, SK            | 15                  | R    | 17    | 3     | 58130-ZY3-017A | 031064 |
| 19'-22' - AL, SK            | 15-1/2              | R    | 18    | 3     |                | 031052 |
| 18'-22' - AL, SK            | 14                  | R    | 19    | 3     |                | 031025 |
| 18'-22' - AL, SK            | 14-1/2              | R    | 19    | 3     | 58130-ZY3-019A | 031065 |
| 18'-20' - AL, SK            | 13-3/4              | R    | 21    | 3     |                | 031026 |
| 18'-20' - AL, SK            | 14-1/4              | R    | 21    | 3     | 58130-ZY3-021A | 031066 |
| 17'-20' - AL, SK            |                     |      |       |       |                |        |
| 17'-20' - AL, SK            |                     |      |       |       |                |        |
| Up to 18'                   |                     |      |       |       |                |        |
| High Performance            |                     |      |       |       |                |        |
| High Performance            |                     |      |       |       |                |        |
| High Perf. (EFI)            |                     |      |       |       |                |        |
| High Performance            |                     |      |       |       |                |        |
| High Performance            |                     |      |       |       |                |        |
| High Perf. (EFI)            |                     |      |       |       |                |        |

**Rubber Hub Bushing**  
Part # 65-322  
Refer to Pages 53-54 for Details on Attachment Hardware Components.

| STAINLESS STEEL - A SERIES PROPELLERS  |      |       |       |        |                      |      |       |       |        |
|--|------|-------|-------|--------|----------------------|------|-------|-------|--------|
| 3-BLADE BALLISTIC  |      |       |       |        | 3-BLADE BALLISTIC XL |      |       |       |        |
| Dia.   | Rot. | Pitch | Bld # | Part # | Dia.                 | Rot. | Pitch | Bld # | Part # |
| 14-7/8   | R    | 15    | 3     | 933515 |                      |      |       |       |        |
|  |      |       |       |        |                      |      |       |       |        |
| 14-3/4   | R    | 17    | 3     | 933517 |                      |      |       |       |        |
| 14-3/4   | L    | 17    | 3     | 937517 |                      |      |       |       |        |
| 14-1/2   | R    | 19    | 3     | 933519 |                      |      |       |       |        |
| 14-1/2   | L    | 19    | 3     | 937519 |                      |      |       |       |        |
| 14-3/8   | R    | 21    | 3     | 933521 |                      |      |       |       |        |
| 14-3/8   | L    | 21    | 3     | 937521 |                      |      |       |       |        |
| 14-1/4   | R    | 23    | 3     | 933523 |                      |      |       |       |        |
| 14-1/4   | L    | 23    | 3     | 937523 |                      |      |       |       |        |
| 14-1/4   | R    | 25    | 3     | 933525 |                      |      |       |       |        |
|  |      |       |       |        | 14-3/4               | R    | 22    | 3     | 953522 |
|  |      |       |       |        | 14-3/4               | R    | 24    | 3     | 953524 |
|  |      |       |       |        | 14-3/4               | R    | 26    | 3     | 953526 |
|  |      |       |       |        | 4-BLADE BALLISTIC XL |      |       |       |        |
|  |      |       |       |        | 14-1/8               | R    | 23    | 4     | 963523 |
|  |      |       |       |        | 14-1/8               | R    | 25    | 4     | 963525 |
|  |      |       |       |        | 14-1/8               | R    | 27    | 4     | 963527 |

**Drop-In Hub**  
**Use XHS II® Hub Kit**  
**207**  
Refer to Pages 55-57 for Details on Hub Kit Components.

HONDA

**4-6 HORSEPOWER**

Thru Hub Exhaust & 12 Tooth Spline

4 HP 4-Stroke .....1999 & Newer      5 HP 2-Stroke .....1987 & Newer      6 HP 4-Stroke .....1999 & Newer  
 4 HP 2-Stroke .....1987 & Newer

|                             |  | <b>MATCH</b><br>MICHIGAN |      |       |       |              |               |
|-----------------------------|--|--------------------------|------|-------|-------|--------------|---------------|
|                             |  | ALUMINUM PROPELLERS      |      |       |       |              |               |
| Boat Description/<br>Length |  | Dia.                     | Rot. | Pitch | Bld # | OEM Part #   | Part #        |
| Std. Replacement            |  | 7-7/8                    | R    | 8     | 3     | 48-812950A02 | <b>032055</b> |

\* Standard replacement for 4-Stroke models.



032055

Rubber  
Hub  
Bushing  
Part # 65-531

**4-10 HORSEPOWER**

Thru Hub Exhaust & 8 Tooth Spline

4 HP (Model 40) .....1973-1975      7.5 HP (Model 75 / Model 7.5) ..... 1968-1978      9.8 HP (Model 110 / Model 9.8)... 1968-1985  
 4.5 HP (Model 45 / Model 4.5) .....1973-1981

|                             |  | <b>MATCH</b><br>MICHIGAN |      |       |       |             |               |
|-----------------------------|--|--------------------------|------|-------|-------|-------------|---------------|
|                             |  | ALUMINUM PROPELLERS      |      |       |       |             |               |
| Boat Description/<br>Length |  | Dia.                     | Rot. | Pitch | Bld # | OEM Part #  | Part #        |
| Standard Replacement        |  | 9                        | R    | 9     | 2     | 48-47922A10 | <b>032021</b> |
| 14'-16' - AL                |  | 9                        | R    | 7     | 3     | 48-47670A10 | <b>032020</b> |

032021



032020

Rubber  
Hub  
Bushing  
Part # 65-185

**6-15 HORSEPOWER • 2-1/2" GEARCASE**

Thru Hub Exhaust & 8 Tooth Spline

6 HP 2-Stroke (Includes Merc 6) .....1986-2002      9.9 HP 4-Stroke (Not Bigfoot) ..... 1995-2004      15 HP 2-Stroke ..... 1989-2005  
 8 HP 2-Stroke (Includes Merc 8) .....1986-2005      10 HP ..... 1995 & Newer      15 HP 4-Stroke ..... 1999-2006  
 8 HP 4-Stroke (Not Bigfoot) .....1995-2004      10 HP (Sea Pro/Marathon) ..... 1995-2001  
 9.9 HP 2-Stroke (Includes Merc 9.9) .....1986-2005      15 HP (Sea Pro/Marathon) ..... 1995-2001

|                             |  | <b>MATCH</b><br>MICHIGAN |      |        |       |              |                 |
|-----------------------------|--|--------------------------|------|--------|-------|--------------|-----------------|
|                             |  | ALUMINUM PROPELLERS      |      |        |       |              |                 |
| Boat Description/<br>Length |  | Dia.                     | Rot. | Pitch  | Bld # | OEM Part #   | Part #          |
| 15'-20' - AL                |  | 9-1/4                    | R    | 7      | 3     | 48-828152A12 | <b>032056</b>   |
| 14'-20' - AL                |  | 9                        | R    | 8      | 3     | 48-828154A12 | <b>032053</b>   |
| 14'-19' - AL                |  | 9                        | R    | 9      | 3     | 48-828156A12 | <b>032052</b>   |
| 14'-16' - AL                |  | 9                        | R    | 10-1/2 | 3     | 48-828158A12 | ⊗ <b>032050</b> |

032056



Rubber  
Hub  
Bushing  
Part # 65-429

**8-9.9 HORSEPOWER (4-STROKE) • 2-1/2" GEARCASE**

Thru Hub Exhaust & 12 Tooth Spline

8 HP 4-Stroke (Non Bigfoot) .....2005 & Newer      9.9 HP 4-Stroke (Not Bigfoot) .....2005 & Newer

|                             |  | <b>MATCH</b><br>MICHIGAN |      |       |       |              |               |
|-----------------------------|--|--------------------------|------|-------|-------|--------------|---------------|
|                             |  | ALUMINUM PROPELLERS      |      |       |       |              |               |
| Boat Description/<br>Length |  | Dia.                     | Rot. | Pitch | Bld # | OEM Part #   | Part #        |
| 14'-17' - AL                |  | 8-1/2                    | R    | 7     | 3     | 48-897614A10 | <b>142102</b> |
| 13'-16' - AL                |  | 8-1/2                    | R    | 8     | 3     | 48-897618A10 | <b>142103</b> |

142103



Rubber  
Hub  
Bushing  
Part # 65-531

**9.9-25 HORSEPOWER • 3" GEARCASE**

Thru Hub Exhaust & 10 Tooth Spline • **! MUST use Gearcase Adapter Ring supplied with propeller.**

|   |  |   |
|---|--|---|
| 9.9 HP 4-Stroke Bigfoot/Sail .....1999-2005 | 20 HP 2-Stroke (Mercury®)..... 1986-2002 | 25 HP 2-Stroke (Mariner®) .....1985 & Newer |
| 15 HP 4-Stroke Bigfoot/Sail .....1999-2005  | 25 HP 2-Stroke (Mercury®)..... 1980-2005 | 25 HP (Sea Pro/Marathon).....All Years      |
| 18 HP (Mercury®) .....1980-1985             |  |   |

| Boat Description/<br>Length | VORTEX<br>MICHIGAN             |      |       |       |             |        |
|-----------------------------|--------------------------------|------|-------|-------|-------------|--------|
|                             | ALUMINUM - E SERIES PROPELLERS |      |       |       |             |        |
|                             | Dia.                           | Rot. | Pitch | Bld # | OEM Part #  | Part # |
| HB, SB                      | 10-1/2                         | R    | 9     | 3     |             | 992501 |
| 19' & Up                    | 10-1/2                         | R    | 10    | 3     |             | 992502 |
| 15'-19'                     | 10-1/2                         | R    | 11    | 3     | 48-19638A40 | 992503 |
| 13'-17'                     | 10-1/8                         | R    | 12    | 3     | 48-19639A40 | 992504 |
| 13'-17'                     | 10-1/8                         | R    | 13    | 3     | 48-19640A40 | 992505 |
| Up to 14'                   | 10-1/8                         | R    | 14    | 3     |             | 992506 |

Drop-In Hub  
Use XHS® or XHS II® Hub Kit  
**120 OR 220**  
**!**

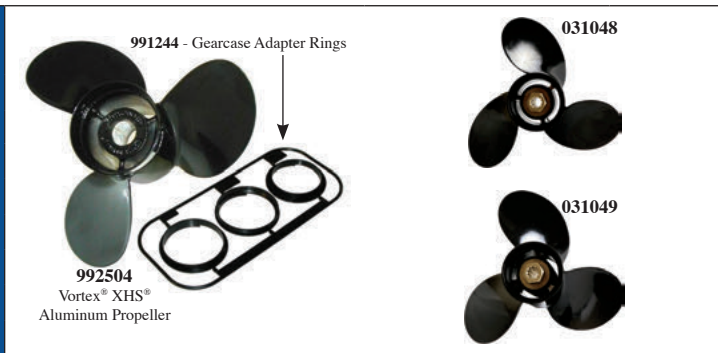

| Boat Description/<br>Length | MATCH<br>MICHIGAN   |      |       |       |             |        |
|-----------------------------|---------------------|------|-------|-------|-------------|--------|
|                             | ALUMINUM PROPELLERS |      |       |       |             |        |
|                             | Dia.                | Rot. | Pitch | Bld # | OEM Part #  | Part # |
| 15'-19'                     | 10-3/8              | R    | 11    | 3     | 48-19638A40 | 031049 |
| 13'-17'                     | 10-3/8              | R    | 13    | 3     | 48-19640A40 | 031048 |
| Up to 14'                   |                     |      |       |       |             |        |

Rubber Hub Bushing  
Part # 65-308

| Boat Description/<br>Length | BALLISTIC<br>MICHIGAN                 |      |       |       |            |        |
|-----------------------------|---------------------------------------|------|-------|-------|------------|--------|
|                             | STAINLESS STEEL - E SERIES PROPELLERS |      |       |       |            |        |
|                             | Dia.                                  | Rot. | Pitch | Bld # | OEM Part # | Part # |
|                             |                                       |      |       |       |            |        |
|                             | 10-1/8                                | R    | 13    | 3     | 48-19644A5 | 933013 |
|                             | 10-1/8                                | R    | 15    | 3     |            | 933015 |

Drop-In Hub  
Use XHS® or XHS II® Hub Kit  
**120 OR 220**  
**!**

**9.9-20 HORSEPOWER**

Thru Hub Exhaust & 14 Tooth Spline

|  |                                  |                                  |
|--|----------------------------------|----------------------------------|
| 9.9 HP Bigfoot .....2005-2013          | 15 HP 4-Stroke .....2007 & Newer | 20 HP 4-Stroke .....2007 & Newer |
| 9.9 HP Command Thrust.....2016 & Newer |                                  |                                  |

| Boat Description/<br>Length | MATCH<br>MICHIGAN   |      |       |       |              |         |
|-----------------------------|---------------------|------|-------|-------|--------------|---------|
|                             | ALUMINUM PROPELLERS |      |       |       |              |         |
|                             | Dia.                | Rot. | Pitch | Bld # | OEM Part #   | Part #  |
| 15'-19' - AL                | 9-1/4               | R    | 8     | 3     | 48-897748A11 | 142203  |
| Standard Replacement        | 9-1/4               | R    | 9     | 3     | 48-897750A11 | *142204 |
| Standard Replacement        | 9-1/4               | R    | 10    | 3     | 48-897752A11 | *142205 |
| Up to 16' - LL              | 9-1/4               | R    | 11    | 3     | 48-897754A11 | 142206  |
| Up to 16' - LL              | 9-1/4               | R    | 12    | 3     |              | 142207  |



142204 Standard Replacement for:  
• 15 HP 4-Stroke

142205 Standard Replacement for:  
• 20 HP 4-Stroke

Rubber Hub Bushing  
Part # 65-369

**20 HORSEPOWER**

Thru Hub Exhaust & 8 Tooth Spline

20 HP (Includes Merc 20 / Merc 200) ....1963-1981

| Boat Description/<br>Length | MATCH<br>MICHIGAN   |      |       |       |            |        |
|-----------------------------|---------------------|------|-------|-------|------------|--------|
|                             | ALUMINUM PROPELLERS |      |       |       |            |        |
|                             | Dia.                | Rot. | Pitch | Bld # | OEM Part # | Part # |
| Standard Replacement        | 9-7/8               | R    | 11    | 2     | 48-33480A1 | 032135 |
| 14'-16' - AL                | 10                  | R    | 9     | 3     | 48-86962A4 | 032136 |



Rubber Hub Bushing  
Part # 65-101

MERCURY / MARINER / SEA RAY

## 15-25 HORSEPOWER • MARINER

Non-Thru Hub Exhaust & Pin Drive

|                     |                     |                     |
|---------------------|---------------------|---------------------|
| 15 HP.....1976-1981 | W15.....1977-1985   | 25 HP.....1977-1979 |
| 15A.....1979-1982   | 20 HP.....1976-1979 |                     |

| Boat Description/<br>Length | MATCH<br>MICHIGAN   |      |       |       |            |        |
|-----------------------------|---------------------|------|-------|-------|------------|--------|
|                             | ALUMINUM PROPELLERS |      |       |       |            |        |
|                             | Dia.                | Rot. | Pitch | Bld # | OEM Part # | Part # |
| HB, SB                      | 9-1/4               | R    | 7     | 3     | 48-96628   | 012102 |
| 12'-14' - HL                | 9                   | R    | 9     | 3     |            | 012109 |
| 12'-14' - HL                | 9                   | R    | 10    | 3     | 48-96625   | 012011 |
| 12'-14' - LL                | 9-1/4               | R    | 11    | 3     | 48-96623   | 012013 |



Rubber  
Hub  
Bushing  
Part # 65-079

## 25-30 HORSEPOWER • MARINER • 3" GEARCASE

Thru Hub Exhaust & 10 Tooth Spline

|                     |                     |                     |
|---------------------|---------------------|---------------------|
| 25 HP.....1980-1984 | 28 HP.....1976-1979 | 30 HP.....1979-1990 |
|---------------------|---------------------|---------------------|

| Boat Description/<br>Length | MATCH<br>MICHIGAN   |      |        |       |            |        |
|-----------------------------|---------------------|------|--------|-------|------------|--------|
|                             | ALUMINUM PROPELLERS |      |        |       |            |        |
|                             | Dia.                | Rot. | Pitch  | Bld # | OEM Part # | Part # |
| 16'-18' - AL, SK            | 9-7/8               | R    | 9      | 3     | 48-81647   | 022001 |
| 14'-17' - AL, SK            | 9-7/8               | R    | 10-1/2 | 3     | 48-81649   | 022002 |
| 13'-16' - LL                | 9-7/8               | R    | 11-1/4 | 3     |            | 022004 |
| 13'-16' - LL                | 9-7/8               | R    | 12     | 3     | 48-82826   | 022003 |
| Up to 13' - LL              | 9-7/8               | R    | 13     | 3     |            | 022005 |
| Up to 13' - LL              | 9-7/8               | R    | 14     | 3     |            | 022006 |

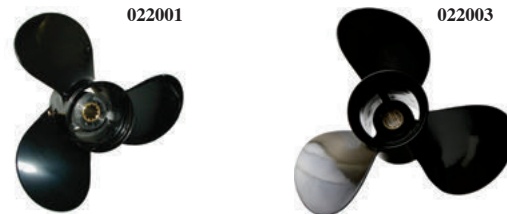

Rubber  
Hub  
Bushing  
Part # 65-265

## 25-30 HORSEPOWER 4-STROKE • MERCURY • 3" GEARCASE

Thru Hub Exhaust & 10 Tooth Spline • **! MUST use Gearcase Adapter Ring supplied with propeller.**

|   |   |
|---|---|
| 25 HP 4-Stroke (Not Bigfoot).....2006 & Newer | 30 HP 4-Stroke (Not Bigfoot).....2006 & Newer |
|---|---|

| Boat Description/<br>Length | VORTEX<br>MICHIGAN             |      |       |       |            |        |
|-----------------------------|--------------------------------|------|-------|-------|------------|--------|
|                             | ALUMINUM - E SERIES PROPELLERS |      |       |       |            |        |
|                             | Dia.                           | Rot. | Pitch | Bld # | OEM Part # | Part # |
| 16'-20' - AL                | 10-1/2                         | R    | 9     | 3     |            | 992501 |
| 14'-18' - AL                | 10-1/2                         | R    | 10    | 3     |            | 992502 |
| 14'-18' - AL                | 10-1/2                         | R    | 11    | 3     |            | 992503 |
| 14'-18' - AL                | 10-1/8                         | R    | 12    | 3     |            | 992504 |
| 12'-16' - AL                | 10-1/8                         | R    | 13    | 3     |            | 992505 |
| 12'-16' - AL                | 10-1/8                         | R    | 14    | 3     |            | 992506 |

Drop-In  
Hub  
Use XHS®  
or XHS II®  
Hub Kit  
**122**  
OR  
**222**  
**!**



| Boat Description/<br>Length | MATCH<br>MICHIGAN   |      |       |       |              |        |
|-----------------------------|---------------------|------|-------|-------|--------------|--------|
|                             | ALUMINUM PROPELLERS |      |       |       |              |        |
|                             | Dia.                | Rot. | Pitch | Bld # | OEM Part #   | Part # |
| 16'-20' - AL                | 9-7/8               | R    | 9     | 3     | 48-896892A40 | 141304 |
| 16'-20' - AL                | 9-7/8               | R    | 10    | 3     |              | 141307 |
| 14'-18' - AL                | 9-7/8               | R    | 11    | 3     | 48-896896A40 | 141305 |
| 12'-16' - AL                | 9-7/8               | R    | 12    | 3     |              | 141308 |
| 12'-16' - AL                | 9-7/8               | R    | 13    | 3     | 48-896900A40 | 141306 |
| Up to 16' - LL              | 9-7/8               | R    | 14    | 3     |              | 142309 |

Rubber  
Hub  
Bushing  
Part # 65-370



## 40-65 HORSEPOWER • 3-1/4" GEARCASE

Thru Hub Exhaust & 13 Tooth Spline

40 HP (Model 402) .....1974-1976  
50 HP (Model 500) .....1974-1976

60 HP (Mariner®).....1976

65 HP (Model 650) ..... 1972-1976

| VORTEX<br>MICHIGAN             |      |       |                      |        |      | APOLLO<br>MICHIGAN                    |        |         |             |       |        |             |      |       |       |            |        |
|--------------------------------|------|-------|----------------------|--------|------|---------------------------------------|--------|---------|-------------|-------|--------|-------------|------|-------|-------|------------|--------|
| ALUMINUM - D SERIES PROPELLERS |      |       |                      |        |      | STAINLESS STEEL - D SERIES PROPELLERS |        |         |             |       |        |             |      |       |       |            |        |
| 3-BLADE                        |      |       | LG. DIAMETER 3-BLADE |        |      | 4-BLADE                               |        |         | Drop-In Hub |       |        | Drop-In Hub |      |       |       |            |        |
| Dia.                           | Rot. | Pitch | Part #               | Dia.   | Rot. | Pitch                                 | Part # | Dia.    | Rot.        | Pitch | Part # | Dia.        | Rot. | Pitch | Bld # | OEM Part # | Part # |
|                                |      |       |                      |        |      |                                       |        | 11-1/2  | R           | 8     | 992401 |             |      |       |       |            |        |
|                                |      |       |                      | 12-1/4 | R    | 9                                     | 992601 | 11-1/2  | R           | 9     | 992402 |             |      |       |       |            |        |
|                                |      |       |                      | 11-3/4 | R    | 10                                    | 992602 | 11-1/2  | R           | 10    | 992403 |             |      |       |       |            |        |
| 10-3/8                         | R    | 11    | 992404               | 11-5/8 | R    | 11                                    | 992603 | 4-BLADE |             |       |        |             |      |       |       |            |        |
| 10-3/8                         | R    | 12    | 992405               | 11-3/8 | R    | 12                                    | 992604 | 10-5/8  | R           | 12    | 941212 | 10-3/4      | R    | 12    | 3     |            | 993405 |
| 10-3/8                         | R    | 13    | 992406               | 11-1/8 | R    | 13                                    | 992605 | 10-3/8  | R           | 13    | 941213 | 10-1/2      | R    | 13    | 3     |            | 993406 |
| 10-3/8                         | R    | 14    | 992407               | 11-1/4 | R    | 14                                    | 992606 | 10-1/8  | R           | 14    | 941214 | 10-3/8      | R    | 14    | 3     |            | 993407 |
| 10                             | R    | 15    | 992408               |        |      |                                       |        | 10-1/8  | R           | 15    | 941215 | 10-1/8      | R    | 15    | 3     |            | 993408 |
| 10                             | R    | 16    | 992409               |        |      |                                       |        |         |             |       |        |             |      |       |       |            |        |

| Boat Description/<br>Length |        | MATCH<br>MICHIGAN   |       |            |        |            |      | BALLISTIC<br>MICHIGAN                 |       |            |        |        |      |       |       |            |        |  |
|-----------------------------|--------|---------------------|-------|------------|--------|------------|------|---------------------------------------|-------|------------|--------|--------|------|-------|-------|------------|--------|--|
|                             |        | ALUMINUM PROPELLERS |       |            |        |            |      | STAINLESS STEEL - D SERIES PROPELLERS |       |            |        |        |      |       |       |            |        |  |
| Dia.                        | Rot.   | Pitch               | Bld # | OEM Part # | Part # | Dia.       | Rot. | Pitch                                 | Bld # | OEM Part # | Part # | Dia.   | Rot. | Pitch | Bld # | OEM Part # | Part # |  |
| 19'-22'                     | AL     | 12-1/4              | R     | 9          | 3      |            |      |                                       |       |            |        |        |      |       |       |            |        |  |
| 19'-22'                     | AL     | 11-3/4              | R     | 10         | 3      | 48-61812A1 |      |                                       |       |            |        |        |      |       |       |            |        |  |
| 17'-19'                     | AL, SK | 11-5/8              | R     | 11         | 3      | 48-61814A1 |      |                                       |       |            |        |        |      |       |       |            |        |  |
| 16'-17'                     | CUPPED | 10-5/8              | R     | 12         | 3      |            |      |                                       |       |            |        |        |      |       |       |            |        |  |
| 16'-17'                     | AL, SK | 11-3/8              | R     | 12         | 3      | 48-61816A1 |      |                                       |       |            |        |        |      |       |       |            |        |  |
| 14'-16'                     | CUPPED | 10-3/8              | R     | 13         | 3      |            |      |                                       |       |            |        |        |      |       |       |            |        |  |
| 14'-16'                     | LL     | 11-1/8              | R     | 13         | 3      | 48-61818A1 |      |                                       |       |            |        | 10-1/8 | R    | 13    | 3     |            | 933213 |  |
| 12'-14'                     | CUPPED | 10-1/4              | R     | 14         | 3      |            |      |                                       |       |            |        |        |      |       |       |            |        |  |
| 12'-14'                     | LL     | 11-1/4              | R     | 14         | 3      | 48-61820A1 |      |                                       |       |            |        |        |      |       |       |            |        |  |
| 12'-14'                     | LL     | 11                  | R     | 15         | 3      | 48-61822A1 |      |                                       |       |            |        | 10-1/8 | R    | 15    | 3     |            | 933215 |  |

Drop-In Hub  
Use XHS® or XHS II® Hub Kit  
**114 OR 214**  
Refer to Pages 55-57 for Details on Hub Kit Components.

Rubber Hub Bushing  
Part # 65-205  
Use OEM Fwd Washer 65758 Aft Washer 62124

Drop-In Hub  
Use XHS® or XHS II® Hub Kit  
**114 OR 214**  
Refer to Pages 55-57 for Details on Hub Kit Components.

Drop-In Hub  
Use XHS® or XHS II® Hub Kit  
**114 OR 214**  
Refer to Pages 55-57 for Details on Hub Kit Components.

MERCURY / MARINER / SEA RAY



032046



031074



990407



25-70 HORSEPOWER • 3-1/4" GEARCASE

Thru Hub Exhaust & 13 Tooth Spline

25 HP 4-Stroke/Bigfoot .....1999-2005  
 30 HP 2-Stroke .....1994-2002  
 30 HP 4-Stroke .....1999-2005  
 30 HP (Sea Pro/Marathon) .....1994 & Newer  
 35 HP .....1984-1989  
 40 HP 2-Stroke (Includes Model 402) .....1977 & Newer

40 HP 4-Stroke (Not Bigfoot) .....1997 & Newer  
 40 HP (Sea Pro/Marathon) .....1977 & Newer  
 45 HP .....1986-1989  
 48 HP (Mariner®) .....All Years  
 50 HP 2-Stroke (Includes Model 500) ..1977 & Newer

50 HP 4-Stroke (Not Bigfoot) .....1995 & Newer  
 55 HP (Mercury/Sea Pro/Marathon) ....1995 & Newer  
 60 HP 2-Stroke .....1978 & Newer  
 60 HP 4-Stroke (Not Bigfoot) .....2001 & Newer  
 70 HP (Includes Model 700) .....Thru 1983

**VORTEX**  
MICHIGAN

ALUMINUM - D SERIES PROPELLERS

| 3-BLADE |      |       |        | LG. DIAMETER 3-BLADE |      |       |        | 4-BLADE |      |       |        |
|---------|------|-------|--------|----------------------|------|-------|--------|---------|------|-------|--------|
| Dia.    | Rot. | Pitch | Part # | Dia.                 | Rot. | Pitch | Part # | Dia.    | Rot. | Pitch | Part # |
|         |      |       |        |                      |      |       |        | 11-1/2  | R    | 8     | 992401 |
|         |      |       |        | 12-1/4               | R    | 9     | 992601 | 11-1/2  | R    | 9     | 992402 |
|         |      |       |        | 11-3/4               | R    | 10    | 992602 | 11-1/2  | R    | 10    | 992403 |
| 10-3/8  | R    | 11    | 992404 | 11-5/8               | R    | 11    | 992603 | 4-BLADE |      |       |        |
| 10-3/8  | R    | 12    | 992405 | 11-3/8               | R    | 12    | 992604 | 10-5/8  | R    | 12    | 941212 |
| 10-3/8  | R    | 13    | 992406 | 11-1/8               | R    | 13    | 992605 | 10-3/8  | R    | 13    | 941213 |
| 10-3/8  | R    | 14    | 992407 | 11-1/4               | R    | 14    | 992606 | 10-1/8  | R    | 14    | 941214 |
| 10      | R    | 15    | 992408 |                      |      |       |        | 10-1/8  | R    | 15    | 941215 |
| 10      | R    | 16    | 992409 |                      |      |       |        |         |      |       |        |

Drop-In Hub

Use XHS® or XHS II® Hub Kit

114 OR 214

Refer to Pages 55-57 for Details on Hub Kit Components.

**APOLLO**  
MICHIGAN

STAINLESS STEEL - D SERIES PROPELLERS

| Dia.   | Rot. | Pitch | Bld # | OEM Part #  | Part # |
|--------|------|-------|-------|-------------|--------|
| 10-3/4 | R    | 12    | 3     | 48-855856A5 | 993405 |
| 10-1/2 | R    | 13    | 3     | 48-855858A5 | 993406 |
| 10-3/8 | R    | 14    | 3     | 48-855860A5 | 993407 |
| 10-1/8 | R    | 15    | 3     | 48-855862A5 | 993408 |

Drop-In Hub

Use XHS® or XHS II® Hub Kit

114 OR 214

Refer to Pages 55-57 for Details on Hub Kit Components.

**MATCH**  
MICHIGAN

ALUMINUM PROPELLERS

| Boat Description/<br>Length | Dia.     | Rot.   | Pitch  | Bld # | OEM Part #   | Part #      |
|-----------------------------|----------|--------|--------|-------|--------------|-------------|
|                             | 19' & Up | 12-1/2 | R      | 8     | 3            | 48-42738A10 |
| 19' & Up                    | 12-1/4   | R      | 9      | 3     |              | • 032143    |
| 17'-19' - AL, SK            | 11-1/4   | R      | 10     | 3     | 48-73132A40  | • 031015    |
| 16'-18' - AL, SK            | 12       | R      | 10-1/2 | 3     | 48-42740A10  | • 032142    |
| 16'-18' - AL, SK            | 10-7/8   | R      | 11     | 3     | 48-85632A40  | • 031053    |
| 15'-17' - AL, SK            | 10-3/4   | R      | 12     | 3     | 48-816702A40 | • 031056    |
| 15'-17' - AL, SK            | 10-5/8   | R      | 12     | 3     | 48-73134A40  | • 031016    |
| 14'-17' - AL, SK            | 10-1/2   | R      | 13     | 3     | 48-816704A40 | • 031057    |
| 14'-17' - AL, SK            | 10-3/8   | R      | 13     | 3     | 48-73136A40  | • 031017    |
| 14'-16' - LL                | 10-3/8   | R      | 14     | 3     | 48-816706A40 | • 031058    |
| 14'-16' - LL                | 10-1/4   | R      | 14     | 3     | 48-73138A40  | • 031018    |
| 13'-15' - LL                | 10-1/8   | R      | 15     | 3     | 48-73140A40  | • 031019    |
| Up to 15'                   | 10       | R      | 17     | 3     | 48-73144A40  | • 031020    |

Rubber Hub Bushing Part # 65-264

When Replacing Mercury Reflex Hub with Michigan Match propeller, OEM Thrust Washer P/N 73345A1 Is Required

**BALLISTIC**  
MICHIGAN

STAINLESS STEEL - D SERIES PROPELLERS

| Dia.   | Rot. | Pitch | Bld # | OEM Part # | Part # |
|--------|------|-------|-------|------------|--------|
| 10-1/8 | R    | 13    | 3     |            | 933213 |
| 10-1/8 | R    | 15    | 3     |            | 933215 |

Drop-In Hub

Use XHS® or XHS II® Hub Kit

114 OR 214

Refer to Pages 55-57 for Details on Hub Kit Components.

Note: Mercury® Reflex® Hub System is not compatible with Michigan Wheel XHS Hub Systems.  
 ♦ When replacing Mercury® Reflex® Hub System with Michigan Match propeller, Michigan Forward Thrust Washer P/N 990407 is required.

MERCURY / MARINER / SEA RAY

## 40-140 HORSEPOWER • 4-1/4" GEARCASE

Thru Hub Exhaust & 15 Tooth Spline

|                                     |              |
|-------------------------------------|--------------|
| 40 & 50 HP 4-Stroke / Bigfoot ..... | All Years    |
| 40 HP Command Thrust.....           | 2014 & Newer |
| 40 HP Sea Pro 4-Stroke .....        | 2016 & Newer |
| 50 HP Command Thrust.....           | 2014 & Newer |
| 60 HP 4-Stroke / Bigfoot .....      | 1995 & Newer |
| 60 HP (Sea Pro/Marathon).....       | 1995 & Newer |
| 60 HP Command Thrust.....           | 2014 & Newer |
| 60 HP Sea Pro 4-Stroke .....        | 2016 & Newer |
| 65 HP (Model 650 - 2 Cyl.) .....    | Thru 1971    |
| 65 HP (Model 650 - 4 Cyl.) .....    | 1961-1970    |
| 70 HP.....                          | 1987-1989    |

|                                    |              |
|------------------------------------|--------------|
| 75 HP (Sea Pro/Marathon) .....     | All Years    |
| 75 HP 2-Stroke .....               | 1984-2005    |
| 75 HP 4-Stroke .....               | 2001 & Newer |
| 80 HP .....                        | 1978-1989    |
| 80 HP (Mariner®).....              | 1978-1983    |
| 80 HP (Model 800; 2 & 4 Cyl.)..... | Thru 1977    |
| 80 HP (Yamaha®).....               | 1977-1983    |
| 85 HP (Model 850; 2 & 4 Cyl.)..... | Thru 1977    |
| 90 HP (Yamaha®).....               | 1978-1983    |
| 90 HP 2-Stroke .....               | 1978 & Newer |
| 90 HP 4-Stroke* .....              | 2001 & Newer |

|  |              |
|--|--------------|
| 100 HP .....                             | 1988 & Newer |
| 115 HP (Yamaha®).....                    | 1978-1983    |
| 115 HP .....                             | 1978 & Newer |
| 115 HP 4-Stroke* .....                   | 2001 & Newer |
| 125 HP .....                             | 1994 & Newer |
| 140 HP (Includes Sea Pro/Offshore) ..... | 1978-1981    |
| 140 HP (Yamaha®).....                    | 1978-1979    |
| Models 900-1150-1500.....                | Thru 1977    |

Includes EFI, OptiMax, Pro XS engines.

\*Does not include Command Thrust model.

### VORTEX MICHIGAN

| 3-BL ALUMINUM - B SERIES |      |       |       |        | 4-BL ALUMINUM - B SERIES |      |       |       |        |
|--------------------------|------|-------|-------|--------|--------------------------|------|-------|-------|--------|
| Dia.                     | Rot. | Pitch | Bld # | Part # | Dia.                     | Rot. | Pitch | Bld # | Part # |
| 14                       | R    | 10    | 3     | 992109 |                          |      |       |       |        |
| 14                       | R    | 11    | 3     | 992111 | 13-7/8                   | R    | 11    | 4     | 941411 |
| 14                       | R    | 13    | 3     | 992112 | 13-7/8                   | R    | 13    | 4     | 941413 |
| 13-3/4                   | R    | 15    | 3     | 992113 | 13-3/8                   | R    | 15    | 4     | 941415 |
|                          |      |       |       |        |                          |      |       |       |        |
| 13-1/4                   | R    | 17    | 3     | 992114 | 13                       | R    | 17    | 4     | 941417 |
|                          |      |       |       |        |                          |      |       |       |        |
| 13                       | R    | 19    | 3     | 992115 | 12-1/2                   | R    | 19    | 4     | 941419 |
|                          |      |       |       |        |                          |      |       |       |        |
| 12-3/4                   | R    | 21    | 3     | 992116 |                          |      |       |       |        |

#### Drop-In Hub

Use XHS II® Hub Kit

**202**

USE Gearcase Adapter Ring supplied with propeller.

Refer to Pages 55-57 for Details on Hub Kit Components.

### APOLLO MICHIGAN

| STAINLESS STEEL - B SERIES PROPELLERS |      |       |       |            |          |
|---------------------------------------|------|-------|-------|------------|----------|
| Dia.                                  | Rot. | Pitch | Bld # | OEM Part # | Part #   |
|                                       |      |       |       |            |          |
|                                       |      |       |       |            |          |
| 13-3/8                                | R    | 15    | 3     |            | * 993143 |
| 13-3/8                                | L    | 15    | 3     |            | * 993153 |
| 13-1/4                                | R    | 17    | 3     |            | * 993144 |
| 13-1/4                                | L    | 17    | 3     |            | * 993154 |
| 13-1/8                                | R    | 19    | 3     |            | * 993145 |
| 13-1/8                                | L    | 19    | 3     |            | * 993155 |
| 13                                    | R    | 21    | 3     |            | * 993146 |
| 13                                    | L    | 21    | 3     |            | * 993156 |

#### Drop-In Hub

Use XHS II® Hub Kit

**202**

USE Gearcase Adapter Ring supplied with propeller.

Refer to Pages 55-57 for Details on Hub Kit Components.

### MATCH MICHIGAN

| Boat Description/Length | ALUMINUM PROPELLERS |      |       |       |              |          |
|-------------------------|---------------------|------|-------|-------|--------------|----------|
|                         | Dia.                | Rot. | Pitch | Bld # | OEM Part #   | Part #   |
| 25' & Up - AL           | 14                  | R    | 10    | 3     | 48-854342A45 | 031061   |
| 25' & Up                | 14                  | R    | 11    | 3     | 48-77338A45  | 031254   |
| 22' & Up                | 14                  | R    | 13    | 3     | 48-77340A45  | 031055   |
| 19'-24' - AL            | 13-3/4              | R    | 15    | 3     | 48-77342A45  | 031041   |
| 17'-20' - AL, SK        | 13-1/4              | R    | 17    | 3     | 48-77344A45  | 031042   |
| 16'-19' - AL            | 13                  | R    | 19    | 3     | 48-77346A45  | 031043   |
| 15'-18' - AL            | 12-3/4              | R    | 21    | 3     | 48-77348A45  | 031044   |
| High Performance        | 12-1/2              | R    | 23    | 3     | 48-77350A45  | * 031045 |
| High Performance        |                     |      |       |       |              |          |

#### Rubber Hub Bushing

Part # 65-444

Use

MWM Fwd Washer 990332 or MWM Kit 9660-1 (Fwd Washer, Tab Washer, Propeller Nut)

See Page 27 for details.

### BALLISTIC MICHIGAN

| STAINLESS STEEL - B SERIES PROPELLERS |      |       |       |        |                      |      |       |       |          |
|---------------------------------------|------|-------|-------|--------|----------------------|------|-------|-------|----------|
| 3-BLADE BALLISTIC                     |      |       |       |        | 3-BLADE BALLISTIC XL |      |       |       |          |
| Dia.                                  | Rot. | Pitch | Bld # | Part # | Dia.                 | Rot. | Pitch | Bld # | Part #   |
|                                       |      |       |       |        |                      |      |       |       |          |
|                                       |      |       |       |        |                      |      |       |       |          |
| 13-5/8                                | R    | 15    | 3     | 933415 |                      |      |       |       |          |
| 13-1/2                                | R    | 17    | 3     | 933417 |                      |      |       |       |          |
| 13-3/8                                | R    | 19    | 3     | 933419 |                      |      |       |       |          |
| 13-1/8                                | R    | 21    | 3     | 933421 |                      |      |       |       |          |
|                                       |      |       |       |        | 13-1/2               | R    | 22    | 3     | * 953422 |
|                                       |      |       |       |        | 13-1/2               | R    | 24    | 3     | * 953424 |

#### Drop-In Hub

Use XHS II® Hub Kit

**202**

USE Gearcase Adapter Ring supplied with propeller.

Refer to Pages 55-57 for Details on Hub Kit Components.

Note: \* Replace standard trim tab with Michigan Wheel trim tab P/N 990404.



"...We have had great success with the Ballistic on 22' pontoons with 115 HP 4-Stroke motors. The pontoon boat is faster than a 22' TriToon with a 150 HP 4-Stroke and a stock propeller. Check it out!"

- Lake Keowee Marina  
Seneca, SC



990404



90-300 HORSEPOWER • V-6 (4-3/4") GEARCASE

Thru Hub Exhaust & 15 Tooth Spline

90 HP Command Thrust.....2014 & Newer  
 115 HP Command Thrust.....2014 & Newer  
 135 HP.....1987 & Newer  
 150 HP.....1978 & Newer  
 Add 4" Pitch for Twin Motors  
 Includes DFL, EFI, Magnum, Offshore,  
 Optimax, Sea Pro XRI, Marathon & Verado.

150 HP (Yamaha®).....1979-1983  
 175 HP.....1978 & Newer  
 175 HP (Yamaha®).....1978-1979  
 200 HP.....1978 & Newer  
 220 HP.....1987-1988  
 225 HP.....1980 & Newer  
 225 HP (Sea Pro/Marathon).....All Years

250 HP.....1994 & Newer  
 275 HP.....1990-1994  
 300 HP.....1983; 1999 & Newer  
 3.4 Litre.....1984-1986

\*For engines 300 HP or higher, use "High Horsepower Sleeve" (P/N 991372). See Page 48 for more details.

| VORTEX<br>MICHIGAN |      |       |       |        | 4-BL ALUMINUM - A SERIES |      |       |          |
|--------------------|------|-------|-------|--------|--------------------------|------|-------|----------|
| Dia.               | Rot. | Pitch | Bld # | Part # | Dia.                     | Rot. | Pitch | Part #   |
| 16                 | R    | 13    | 3     | 992001 |                          |      |       |          |
| 15-1/4             | R    | 15    | 3     | 992002 |                          |      |       |          |
| 16                 | R    | 16    | 3     | 931516 |                          |      |       |          |
| 15                 | R    | 17    | 3     | 992003 | 15                       | R    | 16    | 4 992202 |
|                    |      |       |       |        |                          |      |       |          |
| 14-1/2             | R    | 19    | 3     | 992004 | 14-1/2                   | R    | 18    | 4 992203 |
|                    |      |       |       |        |                          |      |       |          |
| 14-1/4             | R    | 21    | 3     | 992005 | 14                       | R    | 20    | 4 992204 |
|                    |      |       |       |        |                          |      |       |          |
| 14                 | R    | 23    | 3     | 992006 |                          |      |       |          |

**Drop-In Hub**  
 Use XHS II® Hub Kit  
**202**  
 Refer to Pages 55-57 for Details on Hub Kit Components.

| APOLLO<br>MICHIGAN    |      |       |          |                          |      |       |          |                  |      |       |          |
|-----------------------|------|-------|----------|--------------------------|------|-------|----------|------------------|------|-------|----------|
| STD. 3-BLADE A SERIES |      |       |          | LG DIA. 3-BLADE A SERIES |      |       |          | 4-BLADE A SERIES |      |       |          |
| Dia.                  | Rot. | Pitch | Part #   | Dia.                     | Rot. | Pitch | Part #   | Dia.             | Rot. | Pitch | Part #   |
| 14-3/8                | R    | 15    | * 993042 |                          |      |       |          |                  |      |       |          |
| 14-3/8                | L    | 15    | * 993052 |                          |      |       |          |                  |      |       |          |
| 14-1/4                | R    | 17    | * 993043 | 15-1/2                   | R    | 17    | * 993023 | 14-5/8           | R    | 16    | * 993203 |
| 14-1/4                | L    | 17    | * 993053 | 15-1/2                   | L    | 17    | * 993033 | 14-5/8           | L    | 16    | * 993213 |
| 14-1/8                | R    | 19    | * 993044 | 15-1/4                   | R    | 19    | * 993024 | 14-3/8           | R    | 18    | * 993204 |
| 14-1/8                | L    | 19    | * 993054 | 15-1/4                   | L    | 19    | * 993034 | 14-3/8           | L    | 18    | * 993214 |
| 14                    | R    | 21    | * 993045 | 14-3/4                   | R    | 21    | * 993025 | 14-1/8           | R    | 20    | * 993205 |
| 14                    | L    | 21    | * 993055 | 14-3/4                   | L    | 21    | * 993035 | 14-1/8           | L    | 20    | * 993215 |
| 13-7/8                | R    | 23    | * 993046 | 14-5/8                   | R    | 23    | * 993026 | 14               | R    | 22    | * 993206 |
| 13-7/8                | L    | 23    | * 993056 | 14-5/8                   | L    | 23    | * 993036 | 14               | L    | 22    | * 993216 |

**Drop-In Hub**  
 Use XHS II® Hub Kit  
**202**  
 Refer to Pages 55-57 for Details on Hub Kit Components.

| Boat Description/<br>Length | MATCH<br>MICHIGAN   |      |       |       |              |        |
|-----------------------------|---------------------|------|-------|-------|--------------|--------|
|                             | ALUMINUM PROPELLERS |      |       |       |              |        |
|                             | Dia.                | Rot. | Pitch | Bld # | OEM Part #   | Part # |
| CR, HB                      | 16                  | R    | 13    | 3     | 48-78114A45  | 031513 |
| 21'-24' - AL                | 15-1/4              | R    | 15    | 3     | 48-78116A45  | 031023 |
| 20'-23' - AL, SK            | 16                  | R    | 16    | 3     | 48-16440A45  | 031516 |
| 19'-23' - AL, SK            | 14-1/2              | R    | 17    | 3     | 48-78118A40  | 031024 |
| 19'-23' - AL, SK            | 15                  | R    | 17    | 3     | 48-832828A45 | 031064 |
| 19'-22' - AL, SK            | 15-1/2              | R    | 18    | 3     | 48-11324A45  | 031052 |
| 18'-22' - AL, SK            | 14                  | R    | 19    | 3     | 48-78120A40  | 031025 |
| 18'-22' - AL, SK            | 14-1/2              | R    | 19    | 3     | 48-832830A45 | 031065 |
| 18'-20' - AL, SK            | 13-3/4              | R    | 21    | 3     | 48-78122A40  | 031026 |
| 18'-20' - AL, SK            | 14-1/4              | R    | 21    | 3     | 48-832832A45 | 031066 |
| 17'-20' - AL, SK            |                     |      |       |       |              |        |
| 17'-20' - AL, SK            |                     |      |       |       |              |        |
| Up to 18'                   |                     |      |       |       |              |        |
| High Performance            |                     |      |       |       |              |        |
| High Performance            |                     |      |       |       |              |        |
| High Performance            |                     |      |       |       |              |        |
| 50-62 MPH                   |                     |      |       |       |              |        |
| 55-67 MPH                   |                     |      |       |       |              |        |
| 60-72 MPH                   |                     |      |       |       |              |        |

**Rubber Hub Bushing**  
 Part # 65-322  
 Use MWM Kit 990312 (Conductivity Washer, Aft Washer) or MWM Kit 9661-1 (Fwd Washer, Conductivity Washer, Tab Washer, Propeller Nut)  
 See Page 27 for details.

| BALLISTIC<br>MICHIGAN  |      |       |       |          |                      |      |       |       |          |
|--|------|-------|-------|----------|----------------------|------|-------|-------|----------|
| STAINLESS STEEL - A SERIES PROPELLERS  |      |       |       |          |                      |      |       |       |          |
| 3-BLADE BALLISTIC  |      |       |       |          | 3-BLADE BALLISTIC XL |      |       |       |          |
| Dia.   | Rot. | Pitch | Bld # | Part #   | Dia.                 | Rot. | Pitch | Bld # | Part #   |
| 14-7/8   | R    | 15    | 3     | * 933515 |                      |      |       |       |          |
| 14-3/4   | R    | 17    | 3     | * 933517 |                      |      |       |       |          |
| 14-3/4   | L    | 17    | 3     | * 937517 |                      |      |       |       |          |
| 14-1/2   | R    | 19    | 3     | * 933519 |                      |      |       |       |          |
| 14-1/2   | L    | 19    | 3     | * 937519 |                      |      |       |       |          |
| 14-3/8   | R    | 21    | 3     | * 933521 |                      |      |       |       |          |
| 14-3/8   | L    | 21    | 3     | * 937521 |                      |      |       |       |          |
| 14-1/4   | R    | 23    | 3     | * 933523 |                      |      |       |       |          |
| 14-1/4   | L    | 23    | 3     | * 937523 |                      |      |       |       |          |
| 14-1/4   | R    | 25    | 3     | * 933525 |                      |      |       |       |          |
|  |      |       |       |          | 14-3/4               | R    | 22    | 3     | * 953522 |
|  |      |       |       |          | 14-3/4               | R    | 24    | 3     | * 953524 |
|  |      |       |       |          | 14-3/4               | R    | 26    | 3     | * 953526 |
|  |      |       |       |          | 4-BLADE BALLISTIC XL |      |       |       |          |
|  |      |       |       |          | 14-1/8               | R    | 23    | 4     | 963523   |
|  |      |       |       |          | 14-1/8               | R    | 25    | 4     | 963525   |
|  |      |       |       |          | 14-1/8               | R    | 27    | 4     | 963527   |

**Drop-In Hub**  
 Use XHS II® Hub Kit  
**202**  
 Refer to Pages 55-57 for Details on Hub Kit Components.

Note: \* Replace standard trim tab with Michigan Wheel trim tab P/N 990404.



## Replacing a Flo-Torq® Hub with Michigan Propellers

### Replacing a Flo-Torq® Drop In Hub Design with Michigan Propellers

Propellers supplied from Mercury®, Mariner® and Force® since 1996 come with the Flo-Torq® II drop in hubs. When switching to Michigan Match® or Ballistic® propellers, change the attaching hardware set-up as follows.

When converting to a Michigan Propeller on a **V-4 gearcase**, eliminate B & C, replace A with H and use existing hardware F & G.

When converting to a Michigan Propeller on a **V-6 gearcase**, eliminate B & C and use A, D, E, F & G as attaching hardware (D & E replace C). Be sure to use high-performance trim tab 822777A1 for stainless steel installations.

Michigan Wheel offers the following attaching hardware kits for these installations:

- 990312 Includes D & E for the V-6 gearcase.
- 990332 Includes Forward Thrust Washer H for V-4 gearcase.
- 9661-1 Includes A, D, E, F & G for the V-6 gearcase.
- 9660-1 Includes H, F & G for the V-4 gearcase.

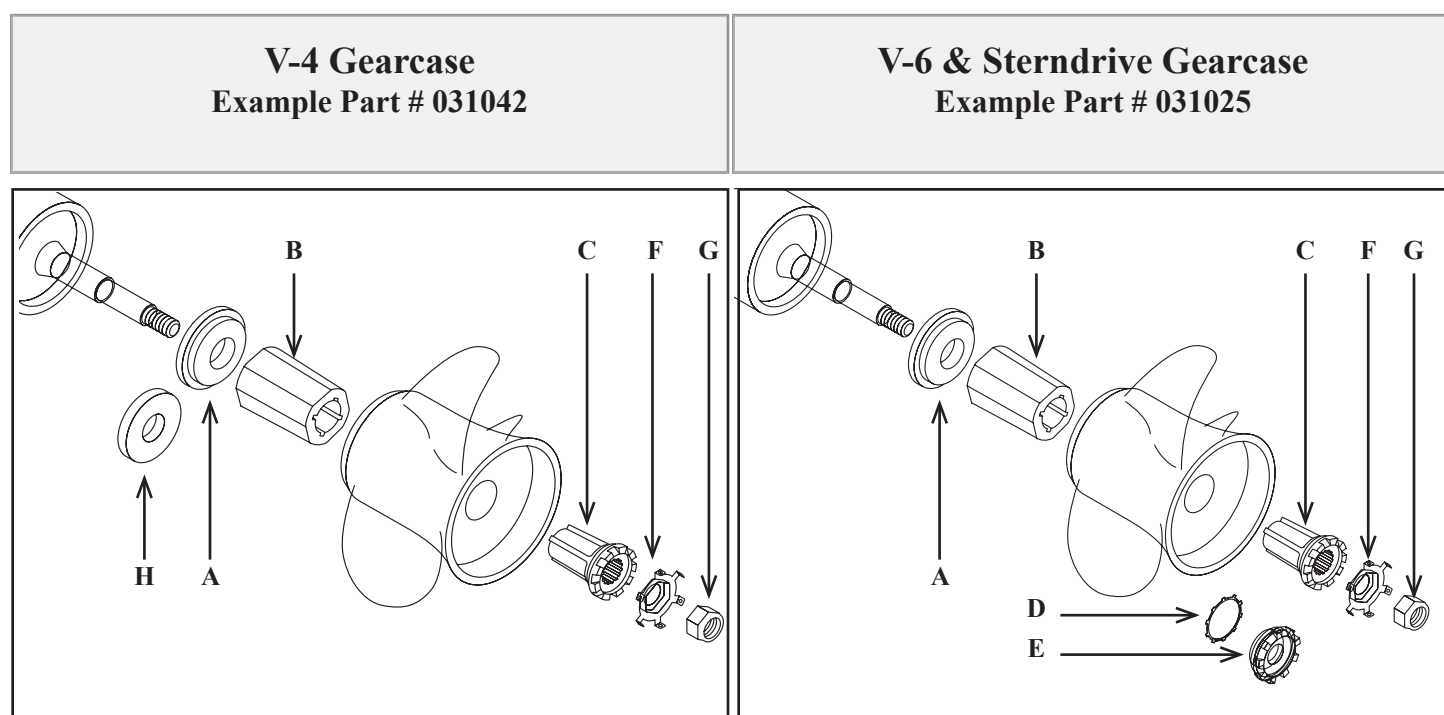

- A) **991204** Forward Thrust Washer
- B) **991301** Plastic Drive Sleeve
- C) **991205** Metal Sleeve Adapter
- D) **990340** Conductivity (Star) Washer

- E) **990348** Aft Castle Washer
- F) **990344** Locking Tab Washer
- G) **990346** Shaft Propeller Nut
- H) **990347** Forward Thrust Washer

**8-9.8 HORSEPOWER (4-STROKE) • 2-1/2" GEARCASE**

Thru Hub Exhaust & 12 Tooth Spline

8 HP 4-Stroke .....2005 & Newer                      9.8 HP 4-Stroke .....2005 & Newer

| Boat Description/<br>Length | MATCH<br>MICHIGAN   |      |       |       |            |        | 142103 |                                        | 142102 Standard Replacement for:<br>• MFS8 / NSF8<br>• MFS9.8 / NSF9.8 (Long Shaft) | Rubber<br>Hub<br>Bushing<br>Part # 65-531 |
|-----------------------------|---------------------|------|-------|-------|------------|--------|--------|--|---|---|
|                             | ALUMINUM PROPELLERS |      |       |       |            |        |        |  |   |   |
|                             | Dia.                | Rot. | Pitch | Bld # | OEM Part # | Part # |        |  |   |   |
| Heavy Loads                 | 8-1/2               | R    | 7     | 3     | 3B2B645140 | 142102 |        | 142103 Standard Replacement for:<br>• M8B / NS8B (Long Shaft)<br>• M9.8B (Long Shaft)<br>• MSF9.8 / NSF9.8 (Short Shaft) |   |   |
| Moderate Loads              | 8-1/2               | R    | 8     | 3     | 3B2B645151 | 142103 |        |  |   |   |

**9.9-20 HORSEPOWER • 2-1/2" GEARCASE**

Thru Hub Exhaust & 14 Tooth Spline



9.9 HP 2-Stroke .....1984 & Newer                      15 HP 2-Stroke .....1985 & Newer                      18 HP 4-Stroke .....2001-2008  
 9.9 HP 4-Stroke .....2000-2003                      15 HP 4-Stroke .....2000 & Newer                      20 HP 4-Stroke .....2007 & Newer  
 12 HP .....1985-1988                      18 HP 2-Stroke .....1985 & Newer

| Boat Description/<br>Length | MATCH<br>MICHIGAN   |      |       |       |            |        | 142206   |   | 142204 Standard Replacement for:<br>• M9.9 / NS9.9 (Short Shaft)<br>• MFS9.9 / NSF 9.9 (Short Shaft)<br>• M15 / NS15 / (Short Shaft)<br>• MFS15 / NSF15 (Long Shaft)<br>• M18 / NS18<br>• MFS18 / NSF18 (Long Shaft)<br>• MFS20 / NSF20 (Long Shaft) | Rubber<br>Hub<br>Bushing<br>Part # 65-369 |
|-----------------------------|---------------------|------|-------|-------|------------|--------|--|---|--|---|
|                             | ALUMINUM PROPELLERS |      |       |       |            |        |  |   |  |   |
|                             | Dia.                | Rot. | Pitch | Bld # | OEM Part # | Part # |  |   |  |   |
| 15'-19' - AL                | 9-1/4               | R    | 8     | 3     | 3BAB645161 | 142203 |  | 142205 Standard Replacement for:<br>• MFS15 / NSF15 (Short Shaft)<br>• MSF18 / NSF18 (Short Shaft)<br>• MSF20 / NSF20 (Short Shaft) | See Pages<br>53-54 for<br>Attachment<br>Hardware   |   |
| 14'-17' - AL                | 9-1/4               | R    | 9     | 3     | 362B641010 | 142204 |  |   |  |   |
| Up to 16' - LL              | 9-1/4               | R    | 10    | 3     | 362B641080 | 142205 | 142203 Standard Replacement for:<br>• M9.9 / NS9.9 (Long Shaft)<br>• MSF9.9 / NSF9.9 (Long Shaft)<br>• M15 / NS15 (Long Shaft) |   |  |   |
| Up to 16' - LL              | 9-1/4               | R    | 11    | 3     |            | 142206 |  |   |  |   |
| Up to 16' - LL              | 9-1/4               | R    | 12    | 3     |            | 142207 |  |   |  |   |

**25-30 HORSEPOWER • 3" GEARCASE**

Thru Hub Exhaust & 10 Tooth Spline • **MUST use Gearcase Adapter Ring supplied with propeller.**

25 HP .....1986-2001                      30 HP .....1985-2001                      30 HP 4-Stroke .....2002 & Newer  
 25 HP 4-Stroke .....2002 & Newer                      30 HP TLDI .....2016 & Newer

| Boat Description/<br>Length | VORTEX<br>MICHIGAN             |      |       |       |             |        | Drop-In<br>Hub<br><br>Use XHS®<br>or XHS II®<br>Hub Kit<br><br>122<br>OR<br>222<br><br> |  | 991244 - Gearcase Adapter Rings<br><br>992504<br>Vortex® XHS®<br>Aluminum Propeller |
|-----------------------------|--------------------------------|------|-------|-------|-------------|--------|--|---|---|
|                             | ALUMINUM - E SERIES PROPELLERS |      |       |       |             |        |  |   |   |
|                             | Dia.                           | Rot. | Pitch | Bld # | OEM Part #  | Part # |  |   |   |
| 16'-20' - AL                | 10-1/2                         | R    | 9     | 3     | 346-64101-5 | 992501 |  |   |   |
| 14'-18' - AL                | 10-1/2                         | R    | 10    | 3     | 346-64102-5 | 992502 |  |   |   |
| 14'-18' - AL                | 10-1/2                         | R    | 11    | 3     | 346-64103-5 | 992503 |  |   |   |
| 14'-18' - AL                | 10-1/8                         | R    | 12    | 3     |             | 992504 |  |   |   |
| 12'-16' - AL                | 10-1/8                         | R    | 13    | 3     | 346-64104-5 | 992505 |  |   |   |
| 12'-16' - AL                | 10-1/8                         | R    | 14    | 3     |             | 992506 |  |   |   |

| Boat Description/<br>Length | MATCH<br>MICHIGAN   |      |        |       |            |        | Rubber<br>Hub<br>Bushing<br>Part # 65-370<br><br>Refer to<br>Pages 53-54<br>for Details<br>on Attachment<br>Hardware<br>Components. | 141306<br><br> | 141305 Standard Replacement for:<br>• M25 / NS25 (Long Shaft)<br>• M30 / NS30 (Long Shaft) |
|-----------------------------|---------------------|------|--------|-------|------------|--------|---|--|--|
|                             | ALUMINUM PROPELLERS |      |        |       |            |        |   |  |  |
|                             | Dia.                | Rot. | Pitch  | Bld # | OEM Part # | Part # |   |  |  |
| 16'-20' - AL                | 9-7/8               | R    | 9      | 3     | 3R0B645180 | 141304 |   | 141306 Standard Replacement for:<br>• M25 / NS25 (Short Shaft)<br>• M30 / NS30 (Short Shaft)       |  |
| 16'-20' - AL                | 9-7/8               | R    | 10     | 3     | 3R0B645210 | 141307 |   |  |  |
| 12'-16' - AL                | 9-7/8               | R    | 11     | 3     | 3R0B645230 | 141305 |   |  |  |
| 12'-16' - AL                | 9-7/8               | R    | 12     | 3     | 3R0B645250 | 141308 |   |  |  |
| Up to 16' - LL              | 9-7/8               | R    | 13     | 3     | 3R0B645270 | 141306 |   |  |  |
| Up to 16' - LL              | 9-7/8               | R    | 14-1/4 | 3     | 349B645291 | 142309 |   |  |  |

NISSAN / TOHATSU

**35-60 HORSEPOWER • 3-1/4" GEARCASE**

Thru Hub Exhaust & 13 Tooth Spline

|  |  |                          |
|--|--|--------------------------|
| 35 HP (35B Only) ..... Thru 1984                         | MFS40 ..... 2015 & Newer   | MSF50 ..... 2015 & Newer |
| 40 HP (Includes TLDI; 40C; M40D; MD40)..... 1984 & Newer | 50 HP (Except 50C - Includes TLDI; M50D; MD50)..... 1992 & Newer | BFT60 ..... 2014 & Newer |

| <b>VORTEX</b><br>MICHIGAN      |      |       |        |                      |      |       |        |                |      |       |        |
|--------------------------------|------|-------|--------|----------------------|------|-------|--------|----------------|------|-------|--------|
| ALUMINUM - D SERIES PROPELLERS |      |       |        |                      |      |       |        |                |      |       |        |
| 3-BLADE                        |      |       |        | LG. DIAMETER 3-BLADE |      |       |        | 4-BLADE        |      |       |        |
| Dia.                           | Rot. | Pitch | Part # | Dia.                 | Rot. | Pitch | Part # | Dia.           | Rot. | Pitch | Part # |
|                                |      |       |        |                      |      |       |        | 11-1/2         | R    | 8     | 992401 |
|                                |      |       |        | 12-1/4               | R    | 9     | 992601 | 11-1/2         | R    | 9     | 992402 |
|                                |      |       |        | 11-3/4               | R    | 10    | 992602 | 11-1/2         | R    | 10    | 992403 |
| 10-3/8                         | R    | 11    | 992404 | 11-5/8               | R    | 11    | 992603 | <b>4-BLADE</b> |      |       |        |
| 10-3/8                         | R    | 12    | 992405 | 11-3/8               | R    | 12    | 992604 | 10-5/8         | R    | 12    | 941212 |
| 10-3/8                         | R    | 13    | 992406 | 11-1/8               | R    | 13    | 992605 | 10-3/8         | R    | 13    | 941213 |
| 10-3/8                         | R    | 14    | 992407 | 11-1/4               | R    | 14    | 992606 | 10-1/8         | R    | 14    | 941214 |
| 10                             | R    | 15    | 992408 |                      |      |       |        | 10-1/8         | R    | 15    | 941215 |
| 10                             | R    | 16    | 992409 |                      |      |       |        |                |      |       |        |

**Drop-In Hub**  
Use XHS® or XHS II® Hub Kit  
**113** OR **213** OR **116** OR **216**  
Refer to Pages 55-57 for Details on Hub Kit Components.

| <b>APOLLO</b><br>MICHIGAN             |      |       |       |            |        |  |  |  |  |  |  |
|---------------------------------------|------|-------|-------|------------|--------|--|--|--|--|--|--|
| STAINLESS STEEL - D SERIES PROPELLERS |      |       |       |            |        |  |  |  |  |  |  |
| Dia.                                  | Rot. | Pitch | Bld # | OEM Part # | Part # |  |  |  |  |  |  |
| 10-3/4                                | R    | 12    | 3     | PT4050P12  | 993405 |  |  |  |  |  |  |
| 10-1/2                                | R    | 13    | 3     | PT4050P13  | 993406 |  |  |  |  |  |  |
| 10-3/8                                | R    | 14    | 3     | PT4050P14  | 993407 |  |  |  |  |  |  |
| 10-1/8                                | R    | 15    | 3     | PT4050P15  | 993408 |  |  |  |  |  |  |

**Drop-In Hub**  
Use XHS® or XHS II® Hub Kit  
**113** OR **213** OR **116** OR **216**  
Refer to Pages 55-57 for Details on Hub Kit Components.

| <b>MATCH</b><br>MICHIGAN    |        |      |       |       |            |         |  |  |  |  |  |
|-----------------------------|--------|------|-------|-------|------------|---------|--|--|--|--|--|
| ALUMINUM PROPELLERS         |        |      |       |       |            |         |  |  |  |  |  |
| Boat Description/<br>Length | Dia.   | Rot. | Pitch | Bld # | OEM Part # | Part #  |  |  |  |  |  |
| 19'-21' - AL                | 12-1/4 | R    | 9     | 3     | 3T5B645180 | 142407  |  |  |  |  |  |
| 17'-20' - AL                | 11-3/4 | R    | 10    | 3     |            | 142408  |  |  |  |  |  |
| 16'-19' - AL                | 11-5/8 | R    | 11    | 3     | 3T5B645230 | *142405 |  |  |  |  |  |
| 15'-18' - AL                | 11-3/8 | R    | 12    | 3     | 3T5B645250 | *142409 |  |  |  |  |  |
| 14'-18' - AL                | 11-1/8 | R    | 13    | 3     | 3T5B645270 | *142406 |  |  |  |  |  |
| 14'-16' - AL                | 11-1/4 | R    | 14    | 3     | 3T5B645290 | 142410  |  |  |  |  |  |
| 13'-15' - LL                |        |      |       |       |            |         |  |  |  |  |  |

**Rubber Hub Bushing**  
Part # 65-377  
Refer to Pages 53-54 for Details on Attachment Hardware Components.

| <b>BALLISTIC</b><br>MICHIGAN          |      |       |       |            |        |  |  |  |  |  |  |
|---------------------------------------|------|-------|-------|------------|--------|--|--|--|--|--|--|
| STAINLESS STEEL - D SERIES PROPELLERS |      |       |       |            |        |  |  |  |  |  |  |
| Dia.                                  | Rot. | Pitch | Bld # | OEM Part # | Part # |  |  |  |  |  |  |
| 10-1/8                                | R    | 13    | 3     |            | 933213 |  |  |  |  |  |  |
| 10-1/8                                | R    | 15    | 3     |            | 933215 |  |  |  |  |  |  |

**Drop-In Hub**  
Use XHS® or XHS II® Hub Kit  
**113** OR **213** OR **116** OR **216**

\* 142405 Standard Replacement for M40C / NS40C; 142409 Standard Replacement for M40D / NS40D; 142406 Standard Replacement for MD50 / NS50D

Note: For BFT60 use XHS (Drop-In Hub) Kit #113 / 213.  
For all other engine applications XHS (Drop-In Hub) Kit #116 / 216.

**50-70 HORSEPOWER • 3-1/4" GEARCASE**

Thru Hub Exhaust & 13 Tooth Spline

|                                  |  |   |
|----------------------------------|--|---|
| 50 HP (50C Only) ..... 1987-1991 | 60A & 60B (Excludes 60C) ..... 1986-1999 | 70A & 70B (Excludes 70C)..... 1981-1995 |
| 55 HP..... 1981-1988             | For 60C & 70C, See 60-140 HP (Pg. 31).   |   |

| <b>VORTEX</b><br>MICHIGAN      |      |       |        |                      |      |       |        |         |      |       |        |
|--------------------------------|------|-------|--------|----------------------|------|-------|--------|---------|------|-------|--------|
| ALUMINUM - C SERIES PROPELLERS |      |       |        |                      |      |       |        |         |      |       |        |
| 3-BLADE                        |      |       |        | LG. DIAMETER 3-BLADE |      |       |        | 4-BLADE |      |       |        |
| Dia.                           | Rot. | Pitch | Part # | Dia.                 | Rot. | Pitch | Part # | Dia.    | Rot. | Pitch | Part # |
|                                |      |       |        |                      |      |       |        | 11-1/2  | R    | 8     | 992401 |
|                                |      |       |        |                      |      |       |        | 11-1/2  | R    | 9     | 992402 |
|                                |      |       |        |                      |      |       |        | 11-1/2  | R    | 10    | 992403 |
| 11-3/4                         | R    | 13    | 992301 | 12-1/2               | R    | 13    | 992311 |         |      |       |        |
| 11-3/4                         | R    | 15    | 992302 | 12-1/4               | R    | 15    | 992312 |         |      |       |        |
| 11-3/4                         | R    | 17    | 992303 |                      |      |       |        |         |      |       |        |

**Drop-In Hub**  
Use XHS® or XHS II® Hub Kit  
**112** OR **212**  
Refer to Pages 55-57 for Details on Hub Kit Components.



**Drop-In Hub**  
Use XHS® or XHS II® Hub Kit  
**112** OR **212**  
Refer to Pages 55-57 for Details on Hub Kit Components.

| <b>BALLISTIC</b><br>MICHIGAN          |      |       |       |            |          |  |  |  |  |  |  |
|---------------------------------------|------|-------|-------|------------|----------|--|--|--|--|--|--|
| STAINLESS STEEL - C SERIES PROPELLERS |      |       |       |            |          |  |  |  |  |  |  |
| Dia.                                  | Rot. | Pitch | Bld # | OEM Part # | Part #   |  |  |  |  |  |  |
| 12-3/8                                | R    | 15    | 3     |            | * 933315 |  |  |  |  |  |  |
| 12                                    | R    | 17    | 3     |            | * 933317 |  |  |  |  |  |  |

**Drop-In Hub**  
Use XHS® or XHS II® Hub Kit  
**112** OR **212**

\* May interfere with trim tab.

**60-90 HORSEPOWER • 4-1/4" GEARCASE**  
Thru Hub Exhaust & 15 Tooth Spline

BFW60.....2014 & Newer

BFT75.....2014 & Newer

BFT90.....2014 & Newer

| <b>VORTEX</b><br>MICHIGAN |      |       |                          |        |                      |
|---------------------------|------|-------|--------------------------|--------|----------------------|
| 3-BL ALUMINUM - B SERIES  |      |       | 4-BL ALUMINUM - B SERIES |        |                      |
| Dia.                      | Rot. | Pitch | Bld #                    | Part # |                      |
| 14                        | R    | 10    | 3                        | 992109 |                      |
| 14                        | R    | 11    | 3                        | 992111 | 13-7/8 R 11 4 941411 |
| 14                        | R    | 13    | 3                        | 992112 | 13-7/8 R 13 4 941413 |
| 13-3/4                    | R    | 15    | 3                        | 992113 | 13-3/8 R 15 4 941415 |
|                           |      |       |                          |        |                      |
| 13-1/4                    | R    | 17    | 3                        | 992114 | 13 R 17 4 941417     |
|                           |      |       |                          |        |                      |
| 13                        | R    | 19    | 3                        | 992115 | 12-1/2 R 19 4 941419 |
|                           |      |       |                          |        |                      |
| 12-3/4                    | R    | 21    | 3                        | 992116 |                      |

**Drop-In Hub**  
**Use XHS II® Hub Kit 207**

USE Gearcase Adapter Ring supplied with propeller.  
Refer to Pages 55-57 for Details on Hub Kit Components.

| <b>APOLLO</b><br>MICHIGAN             |      |       |       |            |        |
|---------------------------------------|------|-------|-------|------------|--------|
| STAINLESS STEEL - B SERIES PROPELLERS |      |       |       |            |        |
| Dia.                                  | Rot. | Pitch | Bld # | OEM Part # | Part # |
|                                       |      |       |       |            |        |
|                                       |      |       |       |            |        |
| 13-3/8                                | R    | 15    | 3     |            | 993143 |
| 13-3/8                                | L    | 15    | 3     |            | 993153 |
| 13-1/4                                | R    | 17    | 3     |            | 993144 |
| 13-1/4                                | L    | 17    | 3     |            | 993154 |
| 13-1/8                                | R    | 19    | 3     |            | 993145 |
| 13-1/8                                | L    | 19    | 3     |            | 993155 |
| 13                                    | R    | 21    | 3     |            | 993146 |
| 13                                    | L    | 21    | 3     |            | 993156 |

**Drop-In Hub**  
**Use XHS II® Hub Kit 207**

USE Gearcase Adapter Ring supplied with propeller.  
Refer to Pages 55-57 for Details on Hub Kit Components.

| Boat Description/Length | <b>MATCH</b><br>MICHIGAN |      |       |       |            |          |
|-------------------------|--------------------------|------|-------|-------|------------|----------|
|                         | ALUMINUM PROPELLERS      |      |       |       |            |          |
|                         | Dia.                     | Rot. | Pitch | Bld # | OEM Part # | Part #   |
| 25' & Up - AL           | 14                       | R    | 10    | 3     |            | 031061   |
| 25' & Up                | 14                       | R    | 11    | 3     |            | 031254   |
| 22' & Up                | 14                       | R    | 13    | 3     |            | 031055   |
| 19'-24' - AL            | 13-3/4                   | R    | 15    | 3     |            | 031041   |
| 17'-20' - AL, SK        | 13-1/4                   | R    | 17    | 3     |            | 031042   |
| 16'-19' - AL            | 13                       | R    | 19    | 3     |            | 031043   |
| 15'-18' - AL            | 12-3/4                   | R    | 21    | 3     |            | 031044   |
| Up to 17' - LL          | 12-1/2                   | R    | 23    | 3     |            | ⊗ 031045 |

**Rubber Hub Bushing**  
Part # 65-444

| <b>BALLISTIC</b><br>MICHIGAN          |      |       |       |          |                      |      |       |       |          |
|---------------------------------------|------|-------|-------|----------|----------------------|------|-------|-------|----------|
| STAINLESS STEEL - B SERIES PROPELLERS |      |       |       |          |                      |      |       |       |          |
| 3-BLADE BALLISTIC                     |      |       |       |          | 3-BLADE BALLISTIC XL |      |       |       |          |
| Dia.                                  | Rot. | Pitch | Bld # | Part #   | Dia.                 | Rot. | Pitch | Bld # | Part #   |
|                                       |      |       |       |          |                      |      |       |       |          |
| 13-5/8                                | R    | 15    | 3     | ⊗ 933415 |                      |      |       |       |          |
| 13-1/2                                | R    | 17    | 3     | ⊗ 933417 |                      |      |       |       |          |
| 13-3/8                                | R    | 19    | 3     | ⊗ 933419 |                      |      |       |       |          |
| 13-1/8                                | R    | 21    | 3     | ⊗ 933421 | 13-1/2               | R    | 22    | 3     | ⊗ 953422 |
|                                       |      |       |       |          | 13-1/2               | R    | 24    | 3     | ⊗ 953424 |

**Drop-In Hub**  
**Use XHS II® Hub Kit 207**

USE Gearcase Adapter Ring supplied with propeller.  
Refer to Pages 55-57 for Details on Hub Kit Components.

**Note:** ⊗ May interfere with trim tab.



**60-140 HORSEPOWER • 4-1/4" GEARCASE**

Thru Hub Exhaust & 15 Tooth Spline

|                                      |                                |                        |
|--------------------------------------|--------------------------------|------------------------|
| 60C (Large Gearcase) ..... Thru 1999 | 90 HP ..... 1987-2001          | 120 HP ..... 1988-2003 |
| 70C (Large Gearcase) ..... Thru 2002 | 90 HP TLDI ..... 2001 & Newer  | 140 HP ..... 1988-2003 |
| 70 HP TLDI ..... 2002-2009           | 115 HP ..... 1992-2001         |                        |
| 75 HP TLDI ..... 2010 & Newer        | 115 HP TLDI ..... 2004 & Newer |                        |

| <b>VORTEX</b><br>MICHIGAN |      |       |                          |        |                      |
|---------------------------|------|-------|--------------------------|--------|----------------------|
| 3-BL ALUMINUM - B SERIES  |      |       | 4-BL ALUMINUM - B SERIES |        |                      |
| Dia.                      | Rot. | Pitch | Bld #                    | Part # |                      |
| 14                        | R    | 10    | 3                        | 992109 |                      |
| 14                        | R    | 11    | 3                        | 992111 | 13-7/8 R 11 4 941411 |
| 14                        | R    | 13    | 3                        | 992112 | 13-7/8 R 13 4 941413 |
| 13-3/4                    | R    | 15    | 3                        | 992113 | 13-3/8 R 15 4 941415 |
|                           |      |       |                          |        |                      |
| 13-1/4                    | R    | 17    | 3                        | 992114 | 13 R 17 4 941417     |
|                           |      |       |                          |        |                      |
| 13                        | R    | 19    | 3                        | 992115 | 12-1/2 R 19 4 941419 |
|                           |      |       |                          |        |                      |
| 12-3/4                    | R    | 21    | 3                        | 992116 |                      |

**Drop-In Hub**

Use XHS II® Hub Kit

**209**

USE Gearcase Adapter Ring supplied with propeller.

Refer to Pages 55-57 for Details on Hub Kit Components.

| <b>APOLLO</b><br>MICHIGAN             |      |       |       |             |        |
|---------------------------------------|------|-------|-------|-------------|--------|
| STAINLESS STEEL - B SERIES PROPELLERS |      |       |       |             |        |
| Dia.                                  | Rot. | Pitch | Bld # | OEM Part #  | Part # |
|                                       |      |       |       |             |        |
|                                       |      |       |       |             |        |
| 13-3/8                                | R    | 15    | 3     | PT70115P15  | 993143 |
| 13-3/8                                | L    | 15    | 3     |             | 993153 |
| 13-1/4                                | R    | 17    | 3     | NM889610170 | 993144 |
| 13-1/4                                | L    | 17    | 3     |             | 993154 |
| 13-1/8                                | R    | 19    | 3     |             | 993145 |
| 13-1/8                                | L    | 19    | 3     |             | 993155 |
| 13                                    | R    | 21    | 3     |             | 993146 |
| 13                                    | L    | 21    | 3     |             | 993156 |

**Drop-In Hub**

Use XHS II® Hub Kit

**209**

USE Gearcase Adapter Ring supplied with propeller.

Refer to Pages 55-57 for Details on Hub Kit Components.

| Boat Description/Length | <b>MATCH</b><br>MICHIGAN |      |       |       |            |        |
|-------------------------|--------------------------|------|-------|-------|------------|--------|
|                         | ALUMINUM PROPELLERS      |      |       |       |            |        |
|                         | Dia.                     | Rot. | Pitch | Bld # | OEM Part # | Part # |
| 22'-29' - AL            | 13-5/8                   | R    | 13    | 3     | 3N4B645271 | 142213 |
| 21'-26' - AL            | 13-1/2                   | R    | 15    | 3     | 3N4B645321 | 142215 |
| 18'-21' - AL            | 13-1/4                   | R    | 17    | 3     | 3N4B645361 | 141217 |
| 17'-20' - AL            | 13                       | R    | 19    | 3     | 3N4B645411 | 141219 |
| 15'-18' - AL            | 12-5/8                   | R    | 21    | 3     | 3N4B645451 | 141221 |

**Rubber Hub Bushing**

Part # 65-376

| <b>BALLISTIC</b><br>MICHIGAN          |      |       |       |            |        |
|---------------------------------------|------|-------|-------|------------|--------|
| STAINLESS STEEL - B SERIES PROPELLERS |      |       |       |            |        |
| Dia.                                  | Rot. | Pitch | Bld # | OEM Part # | Part # |
|                                       |      |       |       |            |        |
| 13-5/8                                | R    | 15    | 3     |            | 933415 |
| 13-1/2                                | R    | 17    | 3     |            | 933417 |
| 13-3/8                                | R    | 19    | 3     |            | 933419 |
| 13-1/8                                | R    | 21    | 3     |            | 933421 |

**Drop-In Hub**

Use XHS II® Hub Kit

**209**

NISSAN / TOHATSU

NISSAN / TOHATSU

**Did You Know?**

You can get assistance sizing a propeller, find your nearest Michigan Wheel dealer, and much more at [www.miwheel.com](http://www.miwheel.com).



**MATCH**  
MICHIGAN



**VORTEX**  
MICHIGAN



**APOLLO**  
MICHIGAN



**BALLISTIC**  
MICHIGAN

Key to Abbreviations: LL = Light Loads; SB = Sailboat; AL = All Loads; SK = Skiboat; WB = Workboat; HB = Houseboat; CR = Cruisers; HL = Heavy Loads; WD = Weedless

**115-250 HORSEPOWER • 4-3/4" GEARCASE**

Thru Hub Exhaust & 15 Tooth Spline

BFT115 .....2014 & Newer  
BFT150 .....2014 & Newer

BFT200.....2014 & Newer  
BFT225.....2014 & Newer

BFT250.....2014 & Newer

**VORTEX**  
MICHIGAN

**APOLLO**  
MICHIGAN

| 3-BL ALUMINUM - A SERIES |      |       |       |        | 4-BL ALUMINUM - A SERIES |      |       |       |        |
|--------------------------|------|-------|-------|--------|--------------------------|------|-------|-------|--------|
| Dia.                     | Rot. | Pitch | Bld # | Part # | Dia.                     | Rot. | Pitch | Bld # | Part # |
| 16                       | R    | 13    | 3     | 992001 |                          |      |       |       |        |
| 15-1/4                   | R    | 15    | 3     | 992002 |                          |      |       |       |        |
| 16                       | R    | 16    | 3     | 931516 |                          |      |       |       |        |
| 15                       | R    | 17    | 3     | 992003 | 15                       | R    | 16    | 4     | 992202 |
|                          |      |       |       |        |                          |      |       |       |        |
| 14-1/2                   | R    | 19    | 3     | 992004 | 14-1/2                   | R    | 18    | 4     | 992203 |
|                          |      |       |       |        |                          |      |       |       |        |
| 14-1/4                   | R    | 21    | 3     | 992005 | 14                       | R    | 20    | 4     | 992204 |
|                          |      |       |       |        |                          |      |       |       |        |
| 14                       | R    | 23    | 3     | 992006 |                          |      |       |       |        |

Drop-In Hub

Use XHS II® Hub Kit

**207**

Refer to Pages 55-57 for Details on Hub Kit Components.

| STD. 3-BLADE A SERIES |      |       |        | LG DIA. 3-BLADE A SERIES |      |       |        | 4-BLADE A SERIES |      |       |        |
|-----------------------|------|-------|--------|--------------------------|------|-------|--------|------------------|------|-------|--------|
| Dia.                  | Rot. | Pitch | Part # | Dia.                     | Rot. | Pitch | Part # | Dia.             | Rot. | Pitch | Part # |
| 14-3/8                | R    | 15    | 993042 |                          |      |       |        |                  |      |       |        |
| 14-3/8                | L    | 15    | 993052 |                          |      |       |        |                  |      |       |        |
| 14-1/4                | R    | 17    | 993043 | 15-1/2                   | R    | 17    | 993023 | 14-5/8           | R    | 16    | 993203 |
| 14-1/4                | L    | 17    | 993053 | 15-1/2                   | L    | 17    | 993033 | 14-5/8           | L    | 16    | 993213 |
| 14-1/8                | R    | 19    | 993044 | 15-1/4                   | R    | 19    | 993024 | 14-3/8           | R    | 18    | 993204 |
| 14-1/8                | L    | 19    | 993054 | 15-1/4                   | L    | 19    | 993034 | 14-3/8           | L    | 18    | 993214 |
| 14                    | R    | 21    | 993045 | 14-3/4                   | R    | 21    | 993025 | 14-1/8           | R    | 20    | 993205 |
| 14                    | L    | 21    | 993055 | 14-3/4                   | L    | 21    | 993035 | 14-1/8           | L    | 20    | 993215 |
| 13-7/8                | R    | 23    | 993046 | 14-5/8                   | R    | 23    | 993026 | 14               | R    | 22    | 993206 |
| 13-7/8                | L    | 23    | 993056 | 14-5/8                   | L    | 23    | 993036 | 14               | L    | 22    | 993216 |

Drop-In Hub

Use XHS II® Hub Kit

**207**

Refer to Pages 55-57 for Details on Hub Kit Components.

**MATCH**  
MICHIGAN

**BALLISTIC**  
MICHIGAN

| Boat Description/<br>Length | ALUMINUM PROPELLERS |      |       |       |                |        |
|-----------------------------|---------------------|------|-------|-------|----------------|--------|
|                             | Dia.                | Rot. | Pitch | Bld # | OEM Part #     | Part # |
| CR, HB                      | 16                  | R    | 13    | 3     | 58130-ZY3-013A | 031513 |
| 21'-24' - AL                | 15-1/4              | R    | 15    | 3     | 58130-ZY3-015A | 031023 |
| 20'-23' - AL, SK            | 16                  | R    | 16    | 3     |                | 031516 |
| 19'-23' - AL, SK            | 14-1/2              | R    | 17    | 3     | 58130-ZY3-017A | 031024 |
| 19'-23' - AL, SK            | 15                  | R    | 17    | 3     |                | 031064 |
| 19'-22' - AL, SK            | 15-1/2              | R    | 18    | 3     |                | 031052 |
| 18'-22' - AL, SK            | 14                  | R    | 19    | 3     | 58130-ZY3-019A | 031025 |
| 18'-22' - AL, SK            | 14-1/2              | R    | 19    | 3     |                | 031065 |
| 18'-20' - AL, SK            | 13-3/4              | R    | 21    | 3     | 58130-ZY3-021A | 031026 |
| 18'-20' - AL, SK            | 14-1/4              | R    | 21    | 3     |                | 031066 |
| 17'-20' - AL, SK            |                     |      |       |       |                |        |
| 17'-20' - AL, SK            |                     |      |       |       |                |        |
| Up to 18'                   |                     |      |       |       |                |        |
| High Performance            |                     |      |       |       |                |        |
| High Performance            |                     |      |       |       |                |        |
| High Perf. (EFI)            |                     |      |       |       |                |        |
| High Performance            |                     |      |       |       |                |        |
| High Performance            |                     |      |       |       |                |        |
| High Perf. (EFI)            |                     |      |       |       |                |        |

Rubber Hub Bushing  
Part # 65-322

| STAINLESS STEEL - A SERIES PROPELLERS |      |       |       |        |                      |      |       |       |        |
|---------------------------------------|------|-------|-------|--------|----------------------|------|-------|-------|--------|
| 3-BLADE BALLISTIC                     |      |       |       |        | 3-BLADE BALLISTIC XL |      |       |       |        |
| Dia.                                  | Rot. | Pitch | Bld # | Part # | Dia.                 | Rot. | Pitch | Bld # | Part # |
| 14-7/8                                | R    | 15    | 3     | 933515 |                      |      |       |       |        |
| 14-3/4                                | R    | 17    | 3     | 933517 |                      |      |       |       |        |
| 14-3/4                                | L    | 17    | 3     | 937517 |                      |      |       |       |        |
| 14-1/2                                | R    | 19    | 3     | 933519 |                      |      |       |       |        |
| 14-1/2                                | L    | 19    | 3     | 937519 |                      |      |       |       |        |
| 14-3/8                                | R    | 21    | 3     | 933521 |                      |      |       |       |        |
| 14-3/8                                | L    | 21    | 3     | 937521 |                      |      |       |       |        |
| 14-1/4                                | R    | 23    | 3     | 933523 |                      |      |       |       |        |
| 14-1/4                                | L    | 23    | 3     | 937523 |                      |      |       |       |        |
| 14-1/4                                | R    | 25    | 3     | 933525 |                      |      |       |       |        |
|                                       |      |       |       |        | 14-3/4               | R    | 22    | 3     | 953522 |
|                                       |      |       |       |        | 14-3/4               | R    | 24    | 3     | 953524 |
|                                       |      |       |       |        | 14-3/4               | R    | 26    | 3     | 953526 |
| <b>4-BLADE BALLISTIC XL</b>           |      |       |       |        |                      |      |       |       |        |
|                                       |      |       |       |        | 14-1/8               | R    | 23    | 4     | 963523 |
|                                       |      |       |       |        | 14-1/8               | R    | 25    | 4     | 963525 |
|                                       |      |       |       |        | 14-1/8               | R    | 27    | 4     | 963527 |

Drop-In Hub

Use XHS II® Hub Kit

**207**

Refer to Pages 55-57 for Details on Hub Kit Components.



NISSAN / TOHATSU

## 8-20 HORSEPOWER • 2-1/2" GEARCASE

Thru Hub Exhaust & 10 Tooth Spline

|                                   |  |                                  |
|-----------------------------------|--|----------------------------------|
| DF 8A 4-Stroke .....2011 & Newer  | DF 9.9A / 9.9B 4-Stroke.....2010 & Newer | DF 15 4-Stroke .....1996 & Newer |
| DT 9.9 .....1983-1987             | DT 15 ..... 1983-1988                    | DF 15A 4-Stroke.....2013 & Newer |
| DF 9.9 4-Stroke..... 1996 & Newer | DT 15C ..... 1989-1997                   | DF 20A 4-Stroke.....2013 & Newer |

| Boat Description/<br>Length | MATCH<br>MICHIGAN   |      |       |       |                 |         | 062103  | 062103 Standard Replacement for:<br>• DF 15A 4-Stroke | Rubber<br>Hub<br>Bushing<br>Part # 65-540 |
|-----------------------------|---------------------|------|-------|-------|-----------------|---------|---|---|---|
|                             | ALUMINUM PROPELLERS |      |       |       |                 |         |   |   |   |
|                             | Dia.                | Rot. | Pitch | Bld # | OEM Part #      | Part #  |   |   |   |
| 14'-19' - AL                | 9-1/4               | R    | 9     | 3     | 58100-90L50-019 | *062103 | 062104 Standard Replacement for:<br>• DF 20A 4-Stroke | See Pages<br>53-54 for<br>Attachment<br>Hardware      |   |
| 14'-19' - AL                | 9-1/4               | R    | 10    | 3     | 58100-90L60-019 | *062104 |   |   |   |
| 14'-16' - LL                | 9-1/4               | R    | 11    | 3     | 58100-89L40-019 | *062105 |   |   |   |

Note: \* All engines require OEM Aft Spacer Washer Part # 57633-93901.

## 20-30 HORSEPOWER • 3" GEARCASE

Thru Hub Exhaust & 10 Tooth Spline • **!** MUST use Gearcase Adapter Ring supplied with propeller.

|                        |   |  |
|------------------------|---|--|
| DT 20 ☆ .....1985-1986 | DF 25 4-Stroke (Includes V-Twin).....2000 & Newer | DT 30 ..... 1987-1997                              |
| DT 20 .....1987-1988   | DF 25R .....2010 & Newer                          | DT 30C ..... 1987-1997                             |
| DT 25 ☆ .....1985-1986 | DF 25A .....2014 & Newer                          | DF 30 4-Stroke ..... 2000-2007                     |
| DT 25 .....1987-1988   | DT 30 ☆ ..... 1983-1986                           | DF 30A .....2014 & Newer                           |
| DT 25C.....1989-2000   |   | Includes 'AQH', 'AR', 'AT', 'ATH', and 'R' models. |

| Boat Description/<br>Length | VORTEX<br>MICHIGAN             |      |       |       |                 |        | Drop-In<br>Hub<br><br>Use XHS®<br>or XHS II®<br>Hub Kit<br><br>121<br>OR<br>221<br><br>! | 992504<br>Vortex® XHS®<br>Aluminum Propeller | 991244<br>Gearcase Adapter Rings | 062205 |
|-----------------------------|--------------------------------|------|-------|-------|-----------------|--------|--|--|----------------------------------|--------|
|                             | ALUMINUM - E SERIES PROPELLERS |      |       |       |                 |        |  |  |                                  |        |
|                             | Dia.                           | Rot. | Pitch | Bld # | OEM Part #      | Part # |  |  |                                  |        |
| 20' & Up - AL               | 10-1/2                         | R    | 9     | 3     | 58100-96370-019 | 992501 | 062205 Standard Replacement for:<br>• DF 25 4-Stroke<br>• DF 25R 4-Stroke                |  |                                  |        |
| 18'-20' - AL                | 10-1/2                         | R    | 10    | 3     | 58100-96470-019 | 992502 |  |  |                                  |        |
| 16'-18' - AL                | 10-1/2                         | R    | 11    | 3     | 58100-96420-019 | 992503 |  |  |                                  |        |
| 14'-16' - AL                | 10-1/8                         | R    | 12    | 3     | 58100-96480-019 | 992504 |  |  |                                  |        |
| 14'-16' - AL                | 10-1/8                         | R    | 13    | 3     | 58100-96490-019 | 992505 |  |  |                                  |        |
| 14'-16' - LL                | 10-1/8                         | R    | 14    | 3     |                 | 992506 |  |  |                                  |        |

| Boat Description/<br>Length | MATCH<br>MICHIGAN   |      |       |       |                 |        | Rubber<br>Hub<br>Bushing<br>Part # 65-339<br><br>Refer to<br>Pages 53-54<br>for Details<br>on Attachment<br>Hardware<br>Components. | BALLISTIC<br>MICHIGAN                 |      |       |       |            |        | Drop-In<br>Hub<br><br>Use XHS®<br>or XHS II®<br>Hub Kit<br><br>121<br>OR<br>221<br><br>! |
|-----------------------------|---------------------|------|-------|-------|-----------------|--------|---|---------------------------------------|------|-------|-------|------------|--------|--|
|                             | ALUMINUM PROPELLERS |      |       |       |                 |        |   | STAINLESS STEEL - E SERIES PROPELLERS |      |       |       |            |        |  |
|                             | Dia.                | Rot. | Pitch | Bld # | OEM Part #      | Part # |   | Dia.                                  | Rot. | Pitch | Bld # | OEM Part # | Part # |  |
| 20' & Up - AL               | 10-1/4              | R    | 9     | 3     | 58100-96371-019 | 062208 |   |                                       |      |       |       |            |        |  |
| 20' & Up - AL               | 10-1/4              | R    | 10    | 3     | 58100-96471-019 | 062204 |   |                                       |      |       |       |            |        |  |
| 17'-20' - AL                | 10-1/4              | R    | 11    | 3     | 58100-96421-019 | 062205 |   |                                       |      |       |       |            |        |  |
| 15'-18' - AL                | 10-1/4              | R    | 12    | 3     | 58100-96481-019 | 062206 |   |                                       |      |       |       |            |        |  |
| 13'-15' - AL                | 10-1/4              | R    | 13    | 3     | 58100-96491-019 | 062207 | 10-1/8  | R                                     | 13   | 3     |       | * 933013   |        |  |
| 13'-15' - AL                | 10-1/4              | R    | 14    | 3     | 58100-95D01-019 | 062209 |   |                                       |      |       |       |            |        |  |
| Up to 15' - LL              | 10-1/4              | R    | 15    | 3     | 58100-96462-019 | 062210 | 10-1/8  | R                                     | 15   | 3     |       | * 933015   |        |  |

Note: \* May interfere with trim tab.

**35-65 HORSEPOWER • 3-1/4" GEARCASE**

Thru Hub Exhaust & 13 Tooth Spline

|                                  |  |  |
|----------------------------------|--|--|
| DT 35C.....1987-1989             | DT 50 & 50M..... 1983-1984                   | DT 60..... 1983-1984                       |
| DT 40.....1983-1998              | DF 50 4-Stroke..... 1999-2010                | DF 60A 4-Stroke (Not 60AV) ...2010 & Newer |
| DF 40 4-Stroke.....1999-2010     | DF 50A 4-Stroke (Not 50AV) .....2010 & Newer | DT 65..... 1985-1997                       |
| DF 40A 4-Stroke.....2010 & Newer | DT 55..... 1985-1997                         |  |

**VORTEX**  
MICHIGAN

ALUMINUM - D SERIES PROPELLERS

| 3-BLADE |      |       |        | LG. DIAMETER 3-BLADE |      |       |        | 4-BLADE        |      |       |        |
|---------|------|-------|--------|----------------------|------|-------|--------|----------------|------|-------|--------|
| Dia.    | Rot. | Pitch | Part # | Dia.                 | Rot. | Pitch | Part # | Dia.           | Rot. | Pitch | Part # |
|         |      |       |        |                      |      |       |        | 11-1/2         | R    | 8     | 992401 |
|         |      |       |        | 12-1/4               | R    | 9     | 992601 | 11-1/2         | R    | 9     | 992402 |
|         |      |       |        | 11-3/4               | R    | 10    | 992602 | 11-1/2         | R    | 10    | 992403 |
| 10-3/8  | R    | 11    | 992404 | 11-5/8               | R    | 11    | 992603 | <b>4-BLADE</b> |      |       |        |
| 10-3/8  | R    | 12    | 992405 | 11-3/8               | R    | 12    | 992604 | 10-5/8         | R    | 12    | 941212 |
| 10-3/8  | R    | 13    | 992406 | 11-1/8               | R    | 13    | 992605 | 10-3/8         | R    | 13    | 941213 |
| 10-3/8  | R    | 14    | 992407 | 11-1/4               | R    | 14    | 992606 | 10-1/8         | R    | 14    | 941214 |
| 10      | R    | 15    | 992408 |                      |      |       |        | 10-1/8         | R    | 15    | 941215 |
| 10      | R    | 16    | 992409 |                      |      |       |        |                |      |       |        |

Drop-In Hub

Use XHS® or XHS II® Hub Kit

**115 OR 215**

Refer to Pages 55-57 for Details on Hub Kit Components.

**APOLLO**  
MICHIGAN

STAINLESS STEEL - D SERIES PROPELLERS

| Dia.   | Rot. | Pitch | Bld # | OEM Part # | Part # |
|--------|------|-------|-------|------------|--------|
| 10-3/4 | R    | 12    | 3     |            | 993405 |
| 10-1/2 | R    | 13    | 3     |            | 993406 |
| 10-3/8 | R    | 14    | 3     |            | 993407 |
| 10-1/8 | R    | 15    | 3     |            | 993408 |

Drop-In Hub

Use XHS® or XHS II® Hub Kit

**115 OR 215**

Refer to Pages 55-57 for Details on Hub Kit Components.

**MATCH**  
MICHIGAN

ALUMINUM PROPELLERS

| Boat Description/<br>Length | Dia.   | Rot. | Pitch | Bld # | OEM Part #      | Part # |
|-----------------------------|--------|------|-------|-------|-----------------|--------|
| 18'-21' - AL                | 12-1/4 | R    | 9     | 3     |                 | 032046 |
| 18'-21' - AL                | 11-3/4 | R    | 10    | 3     | 58100-88L13-019 | 032045 |
| 16'-19' - AL                | 11-1/2 | R    | 11    | 3     | 58100-88L23-019 | 062211 |
| 16'-19' - AL                | 11-1/2 | R    | 12    | 3     | 58100-88LAO-019 | 062212 |
| 14'-18' - AL                | 11-1/2 | R    | 13    | 3     | 58100-92L30-019 | 062213 |
| 14'-18' - AL                | 11-1/2 | R    | 14    | 3     | 58100-88L52-019 | 062214 |
| 13'-15' - AL                | 11-1/4 | R    | 15    | 3     | 58100-88L62-019 | 062215 |
| 13'-15' - LL                | 11-1/8 | R    | 16    | 3     | 58100-88L72-019 | 062216 |
| Up to 15' - LL              | 11     | R    | 17    | 3     | 58100-88L83-019 | 062217 |

Rubber Hub Bushing Part # 65-205

Refer to Pages 53-54 for Details on Attachment Hardware Components.

**BALLISTIC**  
MICHIGAN

STAINLESS STEEL - D SERIES PROPELLERS

| Dia.   | Rot. | Pitch | Bld # | OEM Part # | Part # |
|--------|------|-------|-------|------------|--------|
| 10-1/8 | R    | 13    | 3     |            | 933213 |
| 10-1/8 | R    | 15    | 3     |            | 933215 |

Drop-In Hub

Use XHS® or XHS II® Hub Kit

**115 OR 215**

Refer to Pages 55-57 for Details on Hub Kit Components.

SUZUKI



**Did You Know?**

With a history as storied as Michigan Wheel's, there are a number of propellers that have been discontinued for decades-old engines. Michigan Wheel can aid in locating remaining inventory in the market. Contact us at 1-800-369-4335 for assistance.



**APOLLO**  
MICHIGAN



**BALLISTIC**  
MICHIGAN

SUZUKI



**60-140 HORSEPOWER • 4-1/4" GEARCASE**

Thru Hub Exhaust & 13 Tooth Spline

|                              |                      |                      |
|------------------------------|----------------------|----------------------|
| DF 60 4-Stroke.....1998-2009 | DT 85.....1979-2000  | DT 115.....1981-2001 |
| DF 70 4-Stroke.....1998-2008 | DT 90.....1989-1997  | DT 140.....1981-2001 |
| DT 75.....1983-1997          | DT 100.....1989-2000 |                      |

| VORTEX<br>MICHIGAN       |      |       |                          |        |                      |
|--------------------------|------|-------|--------------------------|--------|----------------------|
| 3-BL ALUMINUM - B SERIES |      |       | 4-BL ALUMINUM - B SERIES |        |                      |
| Dia.                     | Rot. | Pitch | Bld #                    | Part # |                      |
| 14                       | R    | 10    | 3                        | 992109 |                      |
| 14                       | R    | 11    | 3                        | 992111 | 13-7/8 R 11 4 941411 |
| 14                       | R    | 13    | 3                        | 992112 | 13-7/8 R 13 4 941413 |
| 13-3/4                   | R    | 15    | 3                        | 992113 | 13-3/8 R 15 4 941415 |
| 13-1/4                   | R    | 17    | 3                        | 992114 | 13 R 17 4 941417     |
| 13                       | R    | 19    | 3                        | 992115 | 12-1/2 R 19 4 941419 |
| 12-3/4                   | R    | 21    | 3                        | 992116 |                      |

**Drop-In Hub**  
Use XHS II® Hub Kit  
**210**  
Do NOT use Gearcase Adapter Ring supplied with propeller.  
Refer to Pages 55-57 for Details on Hub Kit Components.

| APOLLO<br>MICHIGAN                    |      |       |       |            |        |
|---------------------------------------|------|-------|-------|------------|--------|
| STAINLESS STEEL - B SERIES PROPELLERS |      |       |       |            |        |
| Dia.                                  | Rot. | Pitch | Bld # | OEM Part # | Part # |
| 13-3/8                                | R    | 15    | 3     |            | 993143 |
| 13-3/8                                | L    | 15    | 3     |            | 993153 |
| 13-1/4                                | R    | 17    | 3     |            | 993144 |
| 13-1/4                                | L    | 17    | 3     |            | 993154 |
| 13-1/8                                | R    | 19    | 3     |            | 993145 |
| 13-1/8                                | L    | 19    | 3     |            | 993155 |
| 13                                    | R    | 21    | 3     |            | 993146 |
| 13                                    | L    | 21    | 3     |            | 993156 |

**Drop-In Hub**  
Use XHS II® Hub Kit  
**210**  
Do NOT use Gearcase Adapter Ring supplied with propeller.  
Refer to Pages 55-57 for Details on Hub Kit Components.

| Boat Description/<br>Length | MATCH<br>MICHIGAN   |      |       |       |                 |          |
|-----------------------------|---------------------|------|-------|-------|-----------------|----------|
|                             | ALUMINUM PROPELLERS |      |       |       |                 |          |
|                             | Dia.                | Rot. | Pitch | Bld # | OEM Part #      | Part #   |
| 19'-22' - AL, SK            |                     |      |       |       |                 |          |
| 18'-21' - AL, SK            |                     |      |       |       |                 |          |
| 17'-20' - AL, SK            | 13                  | R    | 19    | 3     | 58100-94522-019 | Ⓢ 061103 |
| 15'-18' - AL, SK            | 13                  | R    | 21    | 3     | 58100-94532-019 | Ⓢ 061104 |

**Rubber Hub Bushing**  
Part # 65-172

| BALLISTIC<br>MICHIGAN                 |      |       |       |            |        |
|---------------------------------------|------|-------|-------|------------|--------|
| STAINLESS STEEL - B SERIES PROPELLERS |      |       |       |            |        |
| Dia.                                  | Rot. | Pitch | Bld # | OEM Part # | Part # |
| 13-5/8                                | R    | 15    | 3     |            | 933415 |
| 13-1/2                                | R    | 17    | 3     |            | 933417 |
| 13-3/8                                | R    | 19    | 3     |            | 933419 |
| 13-1/8                                | R    | 21    | 3     |            | 933421 |

**Drop-In Hub**  
Use XHS II® Hub Kit  
**210**  
Do NOT use Gearcase Adapter Ring supplied with propeller.

**Did You Know?**

If you need specifications on that obsolete propeller, you can visit the Obsolete Part Finder in the Resource Center on [www.miwheel.com](http://www.miwheel.com).



MATCH  
MICHIGAN



VORTEX  
MICHIGAN



APOLLO  
MICHIGAN



BALLISTIC  
MICHIGAN

Key to Abbreviations: LL = Light Loads; SB = Sailboat; AL = All Loads; SK = Skiboat; WB = Workboat; HB = Houseboat; CR = Cruisers; HL = Heavy Loads; WD = Weedless

Ⓢ Limited Inventory Item.

**50-140 HORSEPOWER (4-STROKE) • 4-1/4" GEARCASE**

Thru Hub Exhaust & 15 Tooth Spline

DF 50AV 4-Stroke .....2015 & Newer  
 DF 60AV 4-Stroke .....2015 & Newer  
 DF 70A 4-Stroke .....2009 & Newer  
 DF 80A 4-Stroke .....2009 & Newer

DF 90 4-Stroke ..... 2001-2008  
 DF 90A 4-Stroke .....2009 & Newer  
 DF 100 4-Stroke .....2009 & Newer  
 DF 115 4-Stroke ..... 2001-2012

DF 115A 4-Stroke .....2013 & Newer  
 DF 140 4-Stroke .....2002-2012  
 DF 140A 4-Stroke .....2013 & Newer

| <b>VORTEX</b><br>MICHIGAN |      |       |       |        | <b>APOLLO</b><br>MICHIGAN |      |       |       |        |             |                                       |      |       |       |            |        |             |
|---------------------------|------|-------|-------|--------|---------------------------|------|-------|-------|--------|-------------|---------------------------------------|------|-------|-------|------------|--------|-------------|
| 3-BL ALUMINUM - B SERIES  |      |       |       |        | 4-BL ALUMINUM - B SERIES  |      |       |       |        | Drop-In Hub | STAINLESS STEEL - B SERIES PROPELLERS |      |       |       |            |        | Drop-In Hub |
| Dia.                      | Rot. | Pitch | Bld # | Part # | Dia.                      | Rot. | Pitch | Bld # | Part # |             | Dia.                                  | Rot. | Pitch | Bld # | OEM Part # | Part # |             |
| 14                        | R    | 10    | 3     | 992109 |                           |      |       |       |        |             |                                       |      |       |       |            |        |             |
| 14                        | R    | 11    | 3     | 992111 | 13-7/8                    | R    | 11    | 4     | 941411 |             |                                       |      |       |       |            |        |             |
| 14                        | R    | 13    | 3     | 992112 | 13-7/8                    | R    | 13    | 4     | 941413 |             |                                       |      |       |       |            |        |             |
| 13-3/4                    | R    | 15    | 3     | 992113 | 13-3/8                    | R    | 15    | 4     | 941415 | 13-3/8      | R                                     | 15   | 3     |       | 993143     |        |             |
|                           |      |       |       |        |                           |      |       |       |        | 13-3/8      | L                                     | 15   | 3     |       | 993153     |        |             |
| 13-1/4                    | R    | 17    | 3     | 992114 | 13                        | R    | 17    | 4     | 941417 | 13-1/4      | R                                     | 17   | 3     |       | 993144     |        |             |
|                           |      |       |       |        |                           |      |       |       |        | 13-1/4      | L                                     | 17   | 3     |       | 993154     |        |             |
| 13                        | R    | 19    | 3     | 992115 | 12-1/2                    | R    | 19    | 4     | 941419 | 13-1/8      | R                                     | 19   | 3     |       | 993145     |        |             |
|                           |      |       |       |        |                           |      |       |       |        | 13-1/8      | L                                     | 19   | 3     |       | 993155     |        |             |
| 12-3/4                    | R    | 21    | 3     | 992116 |                           |      |       |       |        | 13          | R                                     | 21   | 3     |       | 993146     |        |             |
|                           |      |       |       |        |                           |      |       |       |        | 13          | L                                     | 21   | 3     |       | 993156     |        |             |

Drop-In Hub  
 Use XHS II® Hub Kit  
**225 / 226 / 227\***  
 USE Gearcase Adapter Ring supplied with propeller.  
 Refer to Pages 55-57 for Details on Hub Kit Components.

Drop-In Hub  
 Use XHS II® Hub Kit  
**225 / 226 / 227\***  
 USE Gearcase Adapter Ring supplied with propeller.  
 Refer to Pages 55-57 for Details on Hub Kit Components.

| Boat Description/<br>Length | <b>MATCH</b><br>MICHIGAN |      |       |       |                 |        | Rubber Hub Bushing<br>Part # 65-441<br><br>Refer to Pages 53-54 for Details on Attachment Hardware Components. | <b>BALLISTIC</b><br>MICHIGAN          |    |   |                      |        |   | Drop-In Hub<br>Use XHS II® Hub Kit<br><b>225 / 226 / 227*</b><br>USE Gearcase Adapter Ring supplied with propeller. |   |        |
|-----------------------------|--------------------------|------|-------|-------|-----------------|--------|--|---------------------------------------|----|---|----------------------|--------|---|---|---|--------|
|                             | ALUMINUM PROPELLERS      |      |       |       |                 |        |  | STAINLESS STEEL - B SERIES PROPELLERS |    |   |                      |        |   |   |   |        |
|                             | Dia.                     | Rot. | Pitch | Bld # | OEM Part #      | Part # |  | 3-BLADE BALLISTIC                     |    |   | 3-BLADE BALLISTIC XL |        |   |   |   |        |
| 20'-24' - AL, SK            | 14                       | R    | 15    | 3     | 990C0-00760-15P | 061020 | 13-5/8   | R                                     | 15 | 3 | 933415               |        |   |   |   |        |
| 17'-19' - AL, SK            | 14                       | R    | 17    | 3     | 990C0-00760-17P | 061024 | 13-1/2   | R                                     | 17 | 3 | 933417               |        |   |   |   |        |
| 17'-19' - AL                | 14                       | R    | 18    | 3     |                 | 061026 |  |                                       |    |   |                      |        |   |   |   |        |
| 16'-18' - AL, SK            | 14                       | R    | 19    | 3     | 990C0-00760-19P | 061028 | 13-3/8   | R                                     | 19 | 3 | 933419               |        |   |   |   |        |
| 15'-18' - AL, SK            | 14                       | R    | 21    | 3     | 990C0-00760-21P | 061032 | 13-1/8   | R                                     | 21 | 3 | 933421               | 13-1/2 | R | 22  | 3 | 953422 |
| High Performance            |                          |      |       |       |                 |        | 13-1/2   | R                                     | 24 | 3 | 953424               |        |   |   |   |        |

Note: For DF 50AV / DF 60AV / DF 90 / DF 100 / DF 115 HP 4-Stroke engine applications use XHS II® (Drop-In Hub) Kit #225.  
 For DF 115A / DF 140 HP / DF 140A 4-Stroke engine applications use XHS II® (Drop-In Hub) Kit #226.  
 For DF 70A / 80A / 90A applications use XHS II® (Drop-In Hub) Kit #227.

**Did You Know?**

Michigan Wheel truly has a global presence, with offices in both England and Dubai, United Arab Emirates.

SUZUKI



**MATCH**  
MICHIGAN



**VORTEX**  
MICHIGAN



**APOLLO**  
MICHIGAN



**BALLISTIC**  
MICHIGAN

Key to Abbreviations: LL = Light Loads; SB = Sailboat; AL = All Loads; SK = Skiboat; WB = Workboat; HB = Houseboat; CR = Cruisers; HL = Heavy Loads; WD = Weedless

**150-300 HORSEPOWER • 4-3/4" GEARCASE**

Thru Hub Exhaust & 15 Tooth Spline

|                       |              |
|-----------------------|--------------|
| DT 150 .....          | 1986-2003    |
| DF 150 4-Stroke ..... | 2006 & Newer |
| DF 150TG .....        | 2014 & Newer |
| DT 175 .....          | 1987-1992    |
| DF 175 4-Stroke ..... | 2006 & Newer |
| DT 175TG .....        | 2014 & Newer |
| DT 200 .....          | 1986-2000    |

|                           |              |
|---------------------------|--------------|
| DF 200 4-Stroke ① .....   | 2004 & Newer |
| DF 200A 4-Stroke .....    | 2015 & Newer |
| DF 200AP 4-Stroke ① ..... | 2015 & Newer |
| DT 225 .....              | 1986-2003    |
| DF 225 4-Stroke ① .....   | 2004 & Newer |

|                           |              |
|---------------------------|--------------|
| DF 250 4-Stroke ① .....   | 2004 & Newer |
| DF 250AP 4-Stroke ① ..... | 2014 & Newer |
| DF 300 4-Stroke ① .....   | 2007 & Newer |
| DF 300AP 4-Stroke ① ..... | 2014 & Newer |

① Listed propeller diameters are slightly less than original equipment propeller.

\*For engines 300 HP or higher, use "High Horsepower Sleeve" (P/N 991372). See Page 48 for more details.

| VORTEX<br>MICHIGAN       |      |       |       |        | 4-BL ALUMINUM - A SERIES |      |       |       |        |
|--------------------------|------|-------|-------|--------|--------------------------|------|-------|-------|--------|
| 3-BL ALUMINUM - A SERIES |      |       |       |        | 4-BL ALUMINUM - A SERIES |      |       |       |        |
| Dia.                     | Rot. | Pitch | Bld # | Part # | Dia.                     | Rot. | Pitch | Bld # | Part # |
| 16                       | R    | 13    | 3     | 992001 |                          |      |       |       |        |
| 15-1/4                   | R    | 15    | 3     | 992002 |                          |      |       |       |        |
| 16                       | R    | 16    | 3     | 931516 |                          |      |       |       |        |
| 15                       | R    | 17    | 3     | 992003 | 15                       | R    | 16    | 4     | 992202 |
|                          |      |       |       |        |                          |      |       |       |        |
| 14-1/2                   | R    | 19    | 3     | 992004 | 14-1/2                   | R    | 18    | 4     | 992203 |
|                          |      |       |       |        |                          |      |       |       |        |
| 14-1/4                   | R    | 21    | 3     | 992005 | 14                       | R    | 20    | 4     | 992204 |
|                          |      |       |       |        |                          |      |       |       |        |
| 14                       | R    | 23    | 3     | 992006 |                          |      |       |       |        |
|                          |      |       |       |        |                          |      |       |       |        |

**Drop-In Hub**  
**Use XHS II® Hub Kit**  
**204**  
Refer to Pages 55-57 for Details on Hub Kit Components.

| APOLLO<br>MICHIGAN    |      |       |        |                          |      |       |        |                  |      |       |        |
|-----------------------|------|-------|--------|--------------------------|------|-------|--------|------------------|------|-------|--------|
| STD. 3-BLADE A SERIES |      |       |        | LG DIA. 3-BLADE A SERIES |      |       |        | 4-BLADE A SERIES |      |       |        |
| Dia.                  | Rot. | Pitch | Part # | Dia.                     | Rot. | Pitch | Part # | Dia.             | Rot. | Pitch | Part # |
| 14-3/8                | R    | 15    | 993042 |                          |      |       |        |                  |      |       |        |
| 14-3/8                | L    | 15    | 993052 |                          |      |       |        |                  |      |       |        |
| 14-1/4                | R    | 17    | 993043 | 15-1/2                   | R    | 17    | 993023 | 14-5/8           | R    | 16    | 993203 |
| 14-1/4                | L    | 17    | 993053 | 15-1/2                   | L    | 17    | 993033 | 14-5/8           | L    | 16    | 993213 |
| 14-1/8                | R    | 19    | 993044 | 15-1/4                   | R    | 19    | 993024 | 14-3/8           | R    | 18    | 993204 |
| 14-1/8                | L    | 19    | 993054 | 15-1/4                   | L    | 19    | 993034 | 14-3/8           | L    | 18    | 993214 |
| 14                    | R    | 21    | 993045 | 14-3/4                   | R    | 21    | 993025 | 14-1/8           | R    | 20    | 993205 |
| 14                    | L    | 21    | 993055 | 14-3/4                   | L    | 21    | 993035 | 14-1/8           | L    | 20    | 993215 |
| 13-7/8                | R    | 23    | 993046 | 14-5/8                   | R    | 23    | 993026 | 14               | R    | 22    | 993206 |
| 13-7/8                | L    | 23    | 993056 | 14-5/8                   | L    | 23    | 993036 | 14               | L    | 22    | 993216 |

**Drop-In Hub**  
**Use XHS II® Hub Kit**  
**204**  
Refer to Pages 55-57 for Details on Hub Kit Components.



| BALLISTIC<br>MICHIGAN                 |      |       |       |          |                      |      |       |       |          |
|---------------------------------------|------|-------|-------|----------|----------------------|------|-------|-------|----------|
| STAINLESS STEEL - A SERIES PROPELLERS |      |       |       |          |                      |      |       |       |          |
| 3-BLADE BALLISTIC                     |      |       |       |          | 3-BLADE BALLISTIC XL |      |       |       |          |
| Dia.                                  | Rot. | Pitch | Bld # | Part #   | Dia.                 | Rot. | Pitch | Bld # | Part #   |
| 14-7/8                                | R    | 15    | 3     | * 933515 |                      |      |       |       |          |
| 14-3/4                                | R    | 17    | 3     | * 933517 |                      |      |       |       |          |
| 14-3/4                                | L    | 17    | 3     | * 937517 |                      |      |       |       |          |
| 14-1/2                                | R    | 19    | 3     | * 933519 |                      |      |       |       |          |
| 14-1/2                                | L    | 19    | 3     | * 937519 |                      |      |       |       |          |
| 14-3/8                                | R    | 21    | 3     | * 933521 |                      |      |       |       |          |
| 14-3/8                                | L    | 21    | 3     | * 937521 |                      |      |       |       |          |
| 14-1/4                                | R    | 23    | 3     | * 933523 |                      |      |       |       |          |
| 14-1/4                                | L    | 23    | 3     | * 937523 |                      |      |       |       |          |
| 14-1/4                                | R    | 25    | 3     | * 933525 |                      |      |       |       |          |
|                                       |      |       |       |          | 14-3/4               | R    | 22    | 3     | * 953522 |
|                                       |      |       |       |          | 14-3/4               | R    | 24    | 3     | * 953524 |
|                                       |      |       |       |          | 14-3/4               | R    | 26    | 3     | * 953526 |
| 4-BLADE BALLISTIC XL                  |      |       |       |          |                      |      |       |       |          |
| 14-1/8                                | R    | 23    | 4     | * 963523 |                      |      |       |       |          |
| 14-1/8                                | R    | 25    | 4     | * 963525 |                      |      |       |       |          |
| 14-1/8                                | R    | 27    | 4     | * 963527 |                      |      |       |       |          |

**Drop-In Hub**  
**Use XHS II® Hub Kit**  
**204**  
Refer to Pages 55-57 for Details on Hub Kit Components.

\* May interfere with trim tab.

**4-6 HORSEPOWER**

Non-Thru Hub Exhaust & 9 Tooth Spline

4 HP 2-Stroke.....1986-1999                      5 HP 2-Stroke ..... 1995-2002                      F6A 4-Stroke (1 Cyl.) .....2011 & Newer  
 F4 4-Stroke..... 1999 & Newer

|                             |  | <b>MATCH</b><br>MICHIGAN |      |       |       |                 |               |
|-----------------------------|--|--------------------------|------|-------|-------|-----------------|---------------|
|                             |  | ALUMINUM PROPELLERS      |      |       |       |                 |               |
| Boat Description/<br>Length |  | Dia.                     | Rot. | Pitch | Bld # | OEM Part #      | Part #        |
|                             |  | 7-1/2                    | R    | 7     | 3     | 6E0-45943-01-00 | <b>102017</b> |
|                             |  | 7-1/2                    | R    | 8     | 3     | 6E0-45941-01-00 | <b>102018</b> |



Rubber  
Hub  
Bushing  
Part # 65-539

**6-9.9 HORSEPOWER**

Thru Hub Exhaust & 7 Tooth Spline • Replaces Yamaha® “N” Series Propellers

6 HP 2-Stroke.....1986-2000                      8 HP 2-Stroke ..... 1986-2009                      F9.9 4-Stroke .....2008 & Newer  
 F6 4-Stroke.....2001-2010                      F8 4-Stroke.....2001 & Newer

|                             |  | <b>MATCH</b><br>MICHIGAN |      |       |       |                 |               |
|-----------------------------|--|--------------------------|------|-------|-------|-----------------|---------------|
|                             |  | ALUMINUM PROPELLERS      |      |       |       |                 |               |
| Boat Description/<br>Length |  | Dia.                     | Rot. | Pitch | Bld # | OEM Part #      | Part #        |
| General Usage               |  | 8-1/2                    | R    | 7-1/2 | 3     | 6G1-45943-00-00 | <b>102002</b> |
|                             |  | 8-1/2                    | R    | 8-1/2 | 3     | 6G1-45943-00-00 | <b>102085</b> |

102002



Rubber  
Hub  
Bushing  
Part # 65-360

**8 HORSEPOWER**

Non-Thru Hub Exhaust & Pin Drive

8 HP.....1976-1983

|                             |  | <b>MATCH</b><br>MICHIGAN |      |       |       |            |               |
|-----------------------------|--|--------------------------|------|-------|-------|------------|---------------|
|                             |  | ALUMINUM PROPELLERS      |      |       |       |            |               |
| Boat Description/<br>Length |  | Dia.                     | Rot. | Pitch | Bld # | OEM Part # | Part #        |
| 14'-16' - AL                |  | 8-1/4                    | R    | 8     | 3     |            | <b>012008</b> |

012008



Rubber  
Hub  
Bushing  
Part # 65-098

**9.9-20 HORSEPOWER • 2-1/2” GEARCASE**

Thru Hub Exhaust & 8 Tooth Spline • Replaces Yamaha® “J” Series Propellers

9.9 HP 2-Stroke.....1984-2009                      15 HP 2-Stroke ..... 1984-2009                      F15 C .....2007 & Newer  
 F9.9 4-Stroke.....2000-2007                      F15 4-Stroke.....1998 & Newer                      F20 4-Stroke .....2007 & Newer

|                             |  | <b>MATCH</b><br>MICHIGAN |      |        |       |                 |               |
|-----------------------------|--|--------------------------|------|--------|-------|-----------------|---------------|
|                             |  | ALUMINUM PROPELLERS      |      |        |       |                 |               |
| Boat Description/<br>Length |  | Dia.                     | Rot. | Pitch  | Bld # | OEM Part #      | Part #        |
| 14'-20' - HL                |  | 9-1/4                    | R    | 8      | 3     | 63V-45947-00-00 | <b>102003</b> |
| 14'-19' - AL                |  | 9-1/4                    | R    | 9      | 3     | 63V-45945-10-00 | <b>102004</b> |
| 14'-19' - AL                |  | 9-1/4                    | R    | 9-3/4  | 3     | 683-45952-00-00 | <b>102106</b> |
| 14'-16' - AL                |  | 9-1/4                    | R    | 10-1/2 | 3     | 683-45943-00-00 | <b>102005</b> |
| Up to 14' - LL              |  | 9-1/4                    | R    | 12     | 3     | 683-45941-00-00 | <b>102107</b> |

102003



102004



Rubber  
Hub  
Bushing  
Part # 65-359

See Pages  
53-54 for  
Attachment  
Hardware

**Did You Know?**

Michigan Wheel propellers intended for use on Yamaha® engines will also fit Parsun® outboards and Selva® 4-Stroke outboards.

Look for the Parsun® and Selva® engine listings on Pages 43-46.

**15-28 HORSEPOWER**

Non-Thru Hub Exhaust & Pin Drive

15A & W15 HP .....1976-1983      25 HP 2 Cyl. .... 1977-1979      28 HP ..... 1976-1978  
 20 HP .....1976-1978

| Boat Description/<br>Length | MATCH<br>MICHIGAN   |      |       |       |                 |        |
|-----------------------------|---------------------|------|-------|-------|-----------------|--------|
|                             | ALUMINUM PROPELLERS |      |       |       |                 |        |
|                             | Dia.                | Rot. | Pitch | Bld # | OEM Part #      | Part # |
| HB, SB                      | 9-1/4               | R    | 7     | 3     | 650-45943-01-36 | 012102 |
| 12'-14' - HL                | 9                   | R    | 9     | 3     |                 | 012109 |
| 12'-14' - HL                | 9                   | R    | 10    | 3     | 651-45947-00-36 | 012011 |
| 12'-14' - AL                | 9-1/4               | R    | 11    | 3     | 653-45941-01-36 | 012013 |



Rubber  
Hub  
Bushing  
Part # 65-079

**20-30 HORSEPOWER • 3" GEARCASE**

Thru Hub Exhaust & 10 Tooth Spline • Replaces Yamaha® "F" Series Propellers • **!** MUST use Gearcase Adapter Ring supplied with propeller.

20 HP .....1996-1997      F25 4-Stroke ..... 1998-2006; 2010 & Newer      30 HP ..... 1983-2002  
 25 HP .....1980 & Newer

| Boat Description/<br>Length | VORTEX<br>MICHIGAN             |      |       |       |            |        |
|-----------------------------|--------------------------------|------|-------|-------|------------|--------|
|                             | ALUMINUM - E SERIES PROPELLERS |      |       |       |            |        |
|                             | Dia.                           | Rot. | Pitch | Bld # | OEM Part # | Part # |
| 16'-18' - AL                | 10-1/2                         | R    | 9     | 3     |            | 992501 |
| 14'-17' - AL                | 10-1/2                         | R    | 10    | 3     |            | 992502 |
| 14'-17' - AL                | 10-1/2                         | R    | 11    | 3     |            | 992503 |
| 13'-16' - LL                | 10-1/8                         | R    | 12    | 3     |            | 992504 |
| 13'-16' - LL                | 10-1/8                         | R    | 13    | 3     |            | 992505 |
| 13'-16' - LL                | 10-1/8                         | R    | 14    | 3     |            | 992506 |

Drop-In  
Hub  
Use XHS®  
or XHS II®  
Hub Kit  
**123**  
OR  
**223**  
**!**

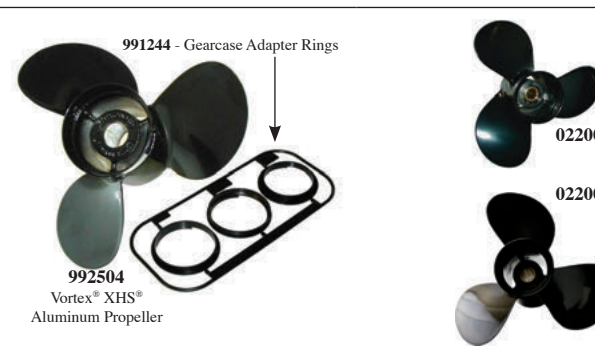

| Boat Description/<br>Length | MATCH<br>MICHIGAN   |      |        |       |                 |        |
|-----------------------------|---------------------|------|--------|-------|-----------------|--------|
|                             | ALUMINUM PROPELLERS |      |        |       |                 |        |
|                             | Dia.                | Rot. | Pitch  | Bld # | OEM Part #      | Part # |
| 16'-18' - AL                | 9-7/8               | R    | 9      | 3     | 664-45941-01-00 | 022001 |
| 15'-17' - AL                | 9-7/8               | R    | 10-1/2 | 3     | 664-45945-00-00 | 022002 |
| 14'-16' - AL                | 9-7/8               | R    | 11-1/4 | 3     | 664-45947-10-00 | 022004 |
| 13'-16' - LL                | 9-7/8               | R    | 12     | 3     | 664-45954-01-00 | 022003 |
| 13'-16' - LL                | 9-7/8               | R    | 13     | 3     | 664-45949-02-00 | 022005 |
| Up to 15' - LL              | 9-7/8               | R    | 14     | 3     | 664-45952-00-00 | 022006 |
| Up to 15' - LL              |                     |      |        |       |                 |        |

Rubber  
Hub  
Bushing  
Part # 65-265  
Refer to  
Pages 53-54  
for Details  
on Attachment  
Hardware  
Components.

| Boat Description/<br>Length | BALLISTIC<br>MICHIGAN                 |      |       |       |            |          |
|-----------------------------|---------------------------------------|------|-------|-------|------------|----------|
|                             | STAINLESS STEEL - E SERIES PROPELLERS |      |       |       |            |          |
|                             | Dia.                                  | Rot. | Pitch | Bld # | OEM Part # | Part #   |
|                             |                                       |      |       |       |            |          |
|                             |                                       |      |       |       |            |          |
|                             |                                       |      |       |       |            |          |
|                             | 10-1/8                                | R    | 13    | 3     |            | * 933013 |
|                             | 10-1/8                                | R    | 15    | 3     |            | * 933015 |

Drop-In  
Hub  
Use XHS®  
or XHS II®  
Hub Kit  
**123**  
OR  
**223**  
**!**

**Note:** \* May interfere with trim tab.  
Gearcase adaptor rings may be slightly larger than engine gearcase.

**Did You Know?**

A recently conducted independent survey, conducted in cooperation with Michigan Wheel, found Michigan Wheel to have the highest overall customer satisfaction among aftermarket propeller manufacturers.



**25-60 HORSEPOWER • 3-1/2" GEARCASE**

Thru Hub Exhaust & 13 Tooth Spline • Replaces Yamaha® "G" Series Propellers

|  |                                  |                               |
|--|----------------------------------|-------------------------------|
| T25 HP.....2010 & Newer                  | 48 HP.....1995-2000              | 55 HP.....1976-1995           |
| F30 4-Stroke.....2001-2005; 2015 & Newer | 50 HP (Not T50).....1984 & Newer | 60 HP.....1976-1991           |
| 40 HP (Includes 40C).....1984 & Newer    | F50 4-Stroke.....1995 & Newer    | F60 4-Stroke.....1999 & Newer |
| F40 4-Stroke.....1999 & Newer            |                                  |                               |

| VORTEX<br>MICHIGAN             |      |       |                         |        |      |       |         |         |      |       |        |
|--------------------------------|------|-------|-------------------------|--------|------|-------|---------|---------|------|-------|--------|
| ALUMINUM - D SERIES PROPELLERS |      |       |                         |        |      |       |         |         |      |       |        |
| 3-BLADE                        |      |       | LG. DIAMETER<br>3-BLADE |        |      |       | 4-BLADE |         |      |       |        |
| Dia.                           | Rot. | Pitch | Part #                  | Dia.   | Rot. | Pitch | Part #  | Dia.    | Rot. | Pitch | Part # |
|                                |      |       |                         |        |      |       |         | 11-1/2  | R    | 8     | 992401 |
|                                |      |       |                         | 12-1/4 | R    | 9     | 992601  | 11-1/2  | R    | 9     | 992402 |
|                                |      |       |                         | 11-3/4 | R    | 10    | 992602  | 11-1/2  | R    | 10    | 992403 |
| 10-3/8                         | R    | 11    | 992404                  | 11-5/8 | R    | 11    | 992603  | 4-BLADE |      |       |        |
| 10-3/8                         | R    | 12    | 992405                  | 11-3/8 | R    | 12    | 992604  | 10-5/8  | R    | 12    | 941212 |
| 10-3/8                         | R    | 13    | 992406                  | 11-1/8 | R    | 13    | 992605  | 10-3/8  | R    | 13    | 941213 |
| 10-3/8                         | R    | 14    | 992407                  | 11-1/4 | R    | 14    | 992606  | 10-1/8  | R    | 14    | 941214 |
| 10                             | R    | 15    | 992408                  |        |      |       |         | 10-1/8  | R    | 15    | 941215 |
| 10                             | R    | 16    | 992409                  |        |      |       |         |         |      |       |        |

**Drop-In Hub**  
Use XHS® or XHS II® Hub Kit  
**117 OR 217**  
Refer to Pages 55-57 for Details on Hub Kit Components.

| APOLLO<br>MICHIGAN                    |      |       |       |                 |        |  |
|---------------------------------------|------|-------|-------|-----------------|--------|--|
| STAINLESS STEEL - D SERIES PROPELLERS |      |       |       |                 |        |  |
| Dia.                                  | Rot. | Pitch | Bld # | OEM Part #      | Part # |  |
| 10-3/4                                | R    | 12    | 3     | MAR-10512-HR-C0 | 993405 |  |
| 10-1/2                                | R    | 13    | 3     | MAR-10513-HR-C0 | 993406 |  |
| 10-3/8                                | R    | 14    | 3     | MAR-10514-HR-C0 | 993407 |  |
| 10-1/8                                | R    | 15    | 3     | MAR-10515-HR-C0 | 993408 |  |

**Drop-In Hub**  
Use XHS® or XHS II® Hub Kit  
**117 OR 217**  
Refer to Pages 55-57 for Details on Hub Kit Components.

| Boat Description/<br>Length | MATCH<br>MICHIGAN   |      |       |       |                 |        |
|-----------------------------|---------------------|------|-------|-------|-----------------|--------|
|                             | ALUMINUM PROPELLERS |      |       |       |                 |        |
|                             | Dia.                | Rot. | Pitch | Bld # | OEM Part #      | Part # |
| 18' & Up - HL               | 12-1/4              | R    | 9     | 3     | 663-45956-01-00 | 032046 |
| 17' & Up - HL               | 11-3/4              | R    | 10    | 3     |                 | 032045 |
| 16'-18' - AL, SK            | 11-5/8              | R    | 11    | 3     | 69W-45947-00-00 | 032044 |
| 15'-17' - CUPPED            | 10-5/8              | R    | 12    | 3     | 6H5-45952-00-00 | 031074 |
| 15'-17' - AL, SK            | 11-3/8              | R    | 12    | 3     | 69W-45952-00-00 | 032043 |
| 14'-17' - CUPPED            | 10-3/8              | R    | 13    | 3     | 6H5-45945-00-00 | 031075 |
| 14'-17' - AL, SK            | 11-1/8              | R    | 13    | 3     | 69W-45945-00-00 | 032042 |
| 14'-16' - CUPPED            | 10-1/4              | R    | 14    |       | 6H5-45958-00-00 | 031076 |
| 14'-16' - LL                | 11-1/4              | R    | 14    | 3     | 69W-45958-00-00 | 032041 |
| 12'-14' - LL                | 11                  | R    | 15    | 3     | 69W-45943-00-00 | 032040 |

**Rubber Hub Bushing**  
Part # 65-205  
Refer to Pages 53-54 for Details on Attachment Hardware Components.

| BALLISTIC<br>MICHIGAN                 |      |       |       |            |        |  |
|---------------------------------------|------|-------|-------|------------|--------|--|
| STAINLESS STEEL - D SERIES PROPELLERS |      |       |       |            |        |  |
| Dia.                                  | Rot. | Pitch | Bld # | OEM Part # | Part # |  |
| 10-1/8                                | R    | 13    | 3     |            | 933213 |  |
| 10-1/8                                | R    | 15    | 3     |            | 933215 |  |

**Drop-In Hub**  
Use XHS® or XHS II® Hub Kit  
**117 OR 217**  
Refer to Pages 55-57 for Details on Hub Kit Components.

**80-140 HORSEPOWER**

Thru Hub Exhaust & 15 Tooth Spline

|                     |                           |                      |
|---------------------|---------------------------|----------------------|
| 80 HP.....1977-1983 | 90 & 115 HP.....1978-1983 | 140 HP.....1978-1979 |
|---------------------|---------------------------|----------------------|

See Mercury® 40-140 HP Product Offering on Page 25.

**150-175 HORSEPOWER**

Thru Hub Exhaust & 15 Tooth Spline

|                      |                      |
|----------------------|----------------------|
| 150 HP.....1979-1983 | 175 HP.....1978-1979 |
|----------------------|----------------------|

See Mercury® V-6 Product Offering on Page 26.

**50-130 HORSEPOWER • 4-1/4" GEARCASE**

Thru Hub Exhaust & 15 Tooth Spline • Replaces Yamaha® "K" Series Propellers

|                                   |              |
|-----------------------------------|--------------|
| T50 HP.....                       | 1996 & Newer |
| T60 HP.....                       | 2003 & Newer |
| 60 HP (Includes C60/E60/P60)..... | 1992-2005    |
| F70 4-Stroke.....                 | 2010 & Newer |
| 70 HP.....                        | 1984 & Newer |
| F75 4-Stroke.....                 | 2003 & Newer |

|                                   |              |
|-----------------------------------|--------------|
| 75 HP (Includes C75/E75/P75)..... | 1994-1999    |
| 80 HP.....                        | 1997         |
| F80 4-Stroke.....                 | 1999-2002    |
| 85 HP.....                        | 1991-1997    |
| F90 4-Stroke.....                 | 1999 & Newer |

|                             |              |
|-----------------------------|--------------|
| 90 HP (Includes C90).....   | 1984 & Newer |
| F100 4-Stroke.....          | 2000 & Newer |
| F115 4-Stroke.....          | 2000 & Newer |
| 115 HP (Includes C115/P115) | 1984 & Newer |
| 130 HP.....                 | 1984 & Newer |

| <b>VORTEX</b><br>MICHIGAN |      |       |                          |        |                      |
|---------------------------|------|-------|--------------------------|--------|----------------------|
| 3-BL ALUMINUM - B SERIES  |      |       | 4-BL ALUMINUM - B SERIES |        |                      |
| Dia.                      | Rot. | Pitch | Bld #                    | Part # |                      |
| 14                        | R    | 10    | 3                        | 992109 |                      |
| 14                        | R    | 11    | 3                        | 992111 | 13-7/8 R 11 4 941411 |
| 14                        | R    | 13    | 3                        | 992112 | 13-7/8 R 13 4 941413 |
| 13-3/4                    | R    | 15    | 3                        | 992113 | 13-3/8 R 15 4 941415 |
| 13-1/4                    | R    | 17    | 3                        | 992114 | 13 R 17 4 941417     |
| 13                        | R    | 19    | 3                        | 992115 | 12-1/2 R 19 4 941419 |
| 12-3/4                    | R    | 21    | 3                        | 992116 |                      |

**Drop-In Hub**  
Use XHS II® Hub Kit  
**203 / 208**  
USE Gearcase Adapter Ring supplied with propeller.  
Refer to Pages 55-57 for Details on Hub Kit Components.

| <b>APOLLO</b><br>MICHIGAN             |      |       |       |                 |          |
|---------------------------------------|------|-------|-------|-----------------|----------|
| STAINLESS STEEL - B SERIES PROPELLERS |      |       |       |                 |          |
| Dia.                                  | Rot. | Pitch | Bld # | OEM Part #      | Part #   |
| 13-3/8                                | R    | 15    | 3     |                 | ✳ 993143 |
| 13-3/8                                | L    | 15    | 3     |                 | ✳ 993153 |
| 13-1/4                                | R    | 17    | 3     | 688-45930-02-00 | ✳ 993144 |
| 13-1/4                                | L    | 17    | 3     | 6L6-45930-01-00 | ✳ 993154 |
| 13-1/8                                | R    | 19    | 3     | 688-45970-03-00 | ✳ 993145 |
| 13-1/8                                | L    | 19    | 3     | 6L6-45970-00-00 | ✳ 993155 |
| 13                                    | R    | 21    | 3     | 688-45972-02-00 | ✳ 993146 |
| 13                                    | L    | 21    | 3     | 6L6-45972-00-00 | ✳ 993156 |

**Drop-In Hub**  
Use XHS II® Hub Kit  
**203 / 208**  
USE Gearcase Adapter Ring supplied with propeller.  
Refer to Pages 55-57 for Details on Hub Kit Components.

| Boat Description/Length | <b>MATCH</b><br>MICHIGAN |      |       |       |                 |        |
|-------------------------|--------------------------|------|-------|-------|-----------------|--------|
|                         | ALUMINUM PROPELLERS      |      |       |       |                 |        |
|                         | Dia.                     | Rot. | Pitch | Bld # | OEM Part #      | Part # |
| 25' & Up                | 14                       | R    | 11    | 3     |                 | 101036 |
| 22'-25' - AL            | 13-5/8                   | R    | 13    | 3     | 6E5-45949-00-00 | 101031 |
| 20'-24' - AL            | 13-1/2                   | R    | 15    | 3     | 6E5-45947-00-00 | 101032 |
| 17'-19' - AL            | 13-1/4                   | R    | 17    | 3     | 6E5-45945-01-00 | 101033 |
| 16'-18' - AL            | 13                       | R    | 19    | 3     | 6E5-45941-00-00 | 101034 |
| 15'-18' - AL            | 12-5/8                   | R    | 21    | 3     |                 | 101035 |
| High Performance        |                          |      |       |       |                 |        |
| High Performance        |                          |      |       |       |                 |        |

**Rubber Hub Bushing**  
Part # 65-441  
Refer to Pages 53-54 for Details on Attachment Hardware Components.

| <b>BALLISTIC</b><br>MICHIGAN          |      |       |                      |          |                        |
|---------------------------------------|------|-------|----------------------|----------|------------------------|
| STAINLESS STEEL - B SERIES PROPELLERS |      |       |                      |          |                        |
| 3-BLADE BALLISTIC                     |      |       | 3-BLADE BALLISTIC XL |          |                        |
| Dia.                                  | Rot. | Pitch | Bld #                | Part #   | Part #                 |
| 13-5/8                                | R    | 15    | 3                    | 933415   |                        |
| 13-1/2                                | R    | 17    | 3                    | 933417   |                        |
| 13-3/8                                | R    | 19    | 3                    | 933419   |                        |
| 13-1/8                                | R    | 21    | 3                    | ✳ 933421 |                        |
|                                       |      |       |                      |          | 13-1/2 R 22 3 ✳ 953422 |
|                                       |      |       |                      |          | 13-1/2 R 24 3 ✳ 953424 |

**Drop-In Hub**  
Use XHS II® Hub Kit  
**203 / 208**  
USE Gearcase Adapter Ring supplied with propeller.  
Refer to Pages 55-57 for Details on Hub Kit Components.

Note: For F75B (4-Stroke), F90B (4-Stroke), 115 HP, F115 (4-Stroke), and 130 HP engine applications use XHS II® (Drop-In Hub) Kit #203. For all other engine applications use XHS II® (Drop-In Hub) Kit #208.

Note: ✳ Michigan Wheel high performance trim tab P/N 990341 is required when using stainless steel propellers on Yamaha 50-130 HP engines.

**150-300 HORSEPOWER • 4-3/4" GEARCASE**

Thru Hub Exhaust & 15 Tooth Spline • Replaces Yamaha® "M" or "T" Series Propellers

|                       |              |
|-----------------------|--------------|
| 150 HP.....           | 1986 & Newer |
| F150 4-Stroke.....    | 2004 & Newer |
| 175 HP.....           | 1984 & Newer |
| F175 4-Stroke.....    | 2014 & Newer |
| 200 HP.....           | 1984 & Newer |
| 200 HP V MAX®.....    | 2001         |
| F200 4-Stroke.....    | 2002 & Newer |
| VF200 V MAX® SHO..... | 2010 & Newer |

|                        |              |
|------------------------|--------------|
| 220 HP (Special) ..... | 1984-1985    |
| 225 HP (Excel) .....   | 1987-1988    |
| 225 HP .....           | 1986 & Newer |
| F225 4-Stroke.....     | 2002 & Newer |
| VF225 V MAX® SHO ..... | 2010 & Newer |
| F225 Offshore .....    | 2010 & Newer |
| 250 HP .....           | 1990 & Newer |
| 250 HP V MAX® .....    | 2001         |

|                        |              |
|------------------------|--------------|
| F250 4-Stroke.....     | 2002 & Newer |
| VF250 V MAX® SHO ..... | 2010 & Newer |
| F250 Offshore.....     | 2010 & Newer |
| 300 HP .....           | 2004-2007    |
| F300 Offshore.....     | 2010 & Newer |

\*For engines 300 HP or higher, use "High Horsepower Sleeve" (P/N 991372). See Page 48 for more details.

**VORTEX**  
MICHIGAN

**APOLLO**  
MICHIGAN

| 3-BL ALUMINUM - A SERIES |      |       |       |        | 4-BL ALUMINUM - A SERIES |      |       |       |        |
|--------------------------|------|-------|-------|--------|--------------------------|------|-------|-------|--------|
| Dia.                     | Rot. | Pitch | Bld # | Part # | Dia.                     | Rot. | Pitch | Bld # | Part # |
| 16                       | R    | 13    | 3     | 992001 |                          |      |       |       |        |
| 15-1/4                   | R    | 15    | 3     | 992002 |                          |      |       |       |        |
| 16                       | R    | 16    | 3     | 931516 |                          |      |       |       |        |
| 15                       | R    | 17    | 3     | 992003 | 15                       | R    | 16    | 4     | 992202 |
|                          |      |       |       |        |                          |      |       |       |        |
| 14-1/2                   | R    | 19    | 3     | 992004 | 14-1/2                   | R    | 18    | 4     | 992203 |
|                          |      |       |       |        |                          |      |       |       |        |
| 14-1/4                   | R    | 21    | 3     | 992005 | 14                       | R    | 20    | 4     | 992204 |
|                          |      |       |       |        |                          |      |       |       |        |
| 14                       | R    | 23    | 3     | 992006 |                          |      |       |       |        |

**Drop-In Hub**  
Use XHS II® Hub Kit  
**203**  
Refer to Pages 55-57 for Details on Hub Kit Components.

| STD. 3-BLADE A SERIES |      |       |        | LG DIA. 3-BLADE A SERIES |      |       |        | 4-BLADE A SERIES |      |       |        |
|-----------------------|------|-------|--------|--------------------------|------|-------|--------|------------------|------|-------|--------|
| Dia.                  | Rot. | Pitch | Part # | Dia.                     | Rot. | Pitch | Part # | Dia.             | Rot. | Pitch | Part # |
| 14-3/8                | R    | 15    | 993042 |                          |      |       |        |                  |      |       |        |
| 14-3/8                | L    | 15    | 993052 |                          |      |       |        |                  |      |       |        |
| 14-1/4                | R    | 17    | 993043 | 15-1/2                   | R    | 17    | 993023 | 14-5/8           | R    | 16    | 993203 |
| 14-1/4                | L    | 17    | 993053 | 15-1/2                   | L    | 17    | 993033 | 14-5/8           | L    | 16    | 993213 |
| 14-1/8                | R    | 19    | 993044 | 15-1/4                   | R    | 19    | 993024 | 14-3/8           | R    | 18    | 993204 |
| 14-1/8                | L    | 19    | 993054 | 15-1/4                   | L    | 19    | 993034 | 14-3/8           | L    | 18    | 993214 |
| 14                    | R    | 21    | 993045 | 14-3/4                   | R    | 21    | 993025 | 14-1/8           | R    | 20    | 993205 |
| 14                    | L    | 21    | 993055 | 14-3/4                   | L    | 21    | 993035 | 14-1/8           | L    | 20    | 993215 |
| 13-7/8                | R    | 23    | 993046 | 14-5/8                   | R    | 23    | 993026 | 14               | R    | 22    | 993206 |
| 13-7/8                | L    | 23    | 993056 | 14-5/8                   | L    | 23    | 993036 | 14               | L    | 22    | 993216 |

**Drop-In Hub**  
Use XHS II® Hub Kit  
**203**  
Refer to Pages 55-57 for Details on Hub Kit Components.

**MATCH**  
MICHIGAN

**BALLISTIC**  
MICHIGAN

| Boat Description/Length | ALUMINUM PROPELLERS |      |       |       |                 |        |
|-------------------------|---------------------|------|-------|-------|-----------------|--------|
|                         | Dia.                | Rot. | Pitch | Bld # | OEM Part #      | Part # |
| 20'-22' - AL, SK        | 15-1/4              | R    | 15    | 3     | 6G5-45941-00-00 | 101025 |
| 19'-21' - AL, SK        | 14-1/2              | R    | 17    | 3     | 6G5-45947-01-00 | 101027 |
| 19'-21' - AL, SK        |                     |      |       |       |                 |        |
| 18'-20' - AL, SK        | 14                  | R    | 19    | 3     | 6G5-45945-01-00 | 101028 |
| 18'-20' - AL, SK        |                     |      |       |       |                 |        |
| 18'-20' - AL, SK        | 13-3/4              | R    | 21    | 3     | 6G5-45943-01-00 | 101029 |
| 18'-20' - AL, SK        |                     |      |       |       |                 |        |
| Up to 18' - AL, SK      |                     |      |       |       |                 |        |
| Up to 18' - AL, SK      |                     |      |       |       |                 |        |
| Up to 18' - AL, SK      |                     |      |       |       |                 |        |
| High Performance        |                     |      |       |       |                 |        |
| High Performance        |                     |      |       |       |                 |        |
| High Performance        |                     |      |       |       |                 |        |
| High Performance        |                     |      |       |       |                 |        |
| High Performance        |                     |      |       |       |                 |        |
| High Performance        |                     |      |       |       |                 |        |
| High Performance        |                     |      |       |       |                 |        |

**Rubber Hub Bushing**  
Part # 65-441  
Refer to Pages 53-54 for Details on Attachment Hardware Components.

| STAINLESS STEEL - A SERIES PROPELLERS |      |       |       |        |                             |      |       |       |          |
|---------------------------------------|------|-------|-------|--------|-----------------------------|------|-------|-------|----------|
| 3-BLADE BALLISTIC                     |      |       |       |        | 3-BLADE BALLISTIC XL        |      |       |       |          |
| Dia.                                  | Rot. | Pitch | Bld # | Part # | Dia.                        | Rot. | Pitch | Bld # | Part #   |
| 14-7/8                                | R    | 15    | 3     | 933515 |                             |      |       |       |          |
| 14-3/4                                | R    | 17    | 3     | 933517 |                             |      |       |       |          |
| 14-3/4                                | L    | 17    | 3     | 937517 |                             |      |       |       |          |
| 14-1/2                                | R    | 19    | 3     | 933519 |                             |      |       |       |          |
| 14-1/2                                | L    | 19    | 3     | 937519 |                             |      |       |       |          |
| 14-3/8                                | R    | 21    | 3     | 933521 |                             |      |       |       |          |
| 14-3/8                                | L    | 21    | 3     | 937521 |                             |      |       |       |          |
| 14-1/4                                | R    | 23    | 3     | 933523 |                             |      |       |       |          |
| 14-1/4                                | L    | 23    | 3     | 937523 |                             |      |       |       |          |
| 14-1/4                                | R    | 25    | 3     | 933525 |                             |      |       |       |          |
|                                       |      |       |       |        | 14-3/4                      | R    | 22    | 3     | * 953522 |
|                                       |      |       |       |        | 14-3/4                      | R    | 24    | 3     | * 953524 |
|                                       |      |       |       |        | 14-3/4                      | R    | 26    | 3     | * 953526 |
|                                       |      |       |       |        | <b>4-BLADE BALLISTIC XL</b> |      |       |       |          |
|                                       |      |       |       |        | 14-1/8                      | R    | 23    | 4     | * 963523 |
|                                       |      |       |       |        | 14-1/8                      | R    | 25    | 4     | * 963525 |
|                                       |      |       |       |        | 14-1/8                      | R    | 27    | 4     | * 963527 |

**Drop-In Hub**  
Use XHS II® Hub Kit  
**203**  
Refer to Pages 55-57 for Details on Hub Kit Components.



\* May interfere with trim tab.



### 6 - 9.9 HORSEPOWER

Thru Hub Exhaust & 7 Tooth Spline

Parsun® 6 HP 4-Stroke .....All Years      Parsun® 8 HP 4-Stroke .....All Years      Parsun® 9.8 HP 4-Stroke .....All Years  
 Selva® 8 HP (Ray) .....2014 & Newer      Selva® 9.9 HP (Pike) .....2014 & Newer

|                             |  | <b>MATCH</b><br>MICHIGAN |      |       |       |                 |               |
|-----------------------------|--|--------------------------|------|-------|-------|-----------------|---------------|
|                             |  | ALUMINUM PROPELLERS      |      |       |       |                 |               |
| Boat Description/<br>Length |  | Dia.                     | Rot. | Pitch | Bld # | OEM Part #      | Part #        |
| General Usage               |  | 8-1/2                    | R    | 7-1/2 | 3     | 6G1-45943-00-00 | <b>102002</b> |
|                             |  | 8-1/2                    | R    | 8-1/2 | 3     | 6G1-45943-00-00 | <b>102085</b> |



Rubber Hub Bushing  
Part # 65-360

### 9.9 - 15 HORSEPOWER • 2-1/2" GEARCASE

Thru Hub Exhaust & 8 Tooth Spline

Parsun® 9.9 HP 4-Stroke .....All Years      Parsun® 15 HP 4-Stroke .....All Years      Parsun® T15 .....All Years  
 Parsun® T9.9 .....All Years  
 Selva® 9.9XS (Wahoo) .....2014 & Newer      Selva® 15 HP (Wahoo) .....2014 & Newer

|                             |  | <b>MATCH</b><br>MICHIGAN |      |        |       |                 |               |
|-----------------------------|--|--------------------------|------|--------|-------|-----------------|---------------|
|                             |  | ALUMINUM PROPELLERS      |      |        |       |                 |               |
| Boat Description/<br>Length |  | Dia.                     | Rot. | Pitch  | Bld # | OEM Part #      | Part #        |
| 14'-20' - HL                |  | 9-1/4                    | R    | 8      | 3     | 63V-45947-00-00 | <b>102003</b> |
| 14'-19' - AL                |  | 9-1/4                    | R    | 9      | 3     | 63V-45945-10-00 | <b>102004</b> |
| 14'-19' - AL                |  | 9-1/4                    | R    | 9-3/4  | 3     | 683-45952-00-00 | <b>102106</b> |
| 14'-16' - AL                |  | 9-1/4                    | R    | 10-1/2 | 3     | 683-45943-00-00 | <b>102005</b> |
| Up to 14' - LL              |  | 9-1/4                    | R    | 12     | 3     | 683-45941-00-00 | <b>102107</b> |

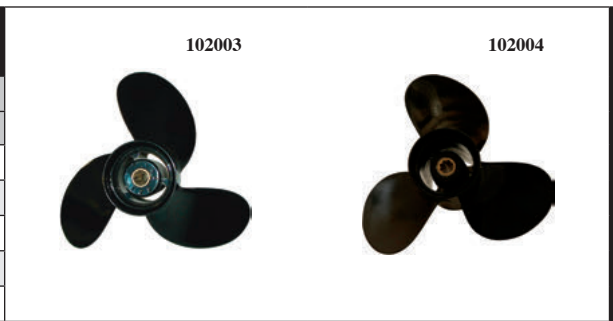

Rubber Hub Bushing  
Part # 65-359

### 20-25 HORSEPOWER • 3" GEARCASE

Thru Hub Exhaust & 10 Tooth Spline **⚠ MUST use Gearcase Adapter Ring supplied with propeller.**

Parsun® 20 HP 4-Stroke .....All Years      Parsun® 25 HP 4-Stroke .....All Years      Parsun® T25 .....All Years  
 Parsun® T20 .....All Years  
 Selva® 25 HP (Kingfish) .....2014 & Newer

|                             |  | <b>VORTEX</b><br>MICHIGAN      |      |       |       |            |               |
|-----------------------------|--|--------------------------------|------|-------|-------|------------|---------------|
|                             |  | ALUMINUM - E SERIES PROPELLERS |      |       |       |            |               |
| Boat Description/<br>Length |  | Dia.                           | Rot. | Pitch | Bld # | OEM Part # | Part #        |
| 16'-18' - AL                |  | 10-1/2                         | R    | 9     | 3     |            | <b>992501</b> |
| 14'-17' - AL                |  | 10-1/2                         | R    | 10    | 3     |            | <b>992502</b> |
| 14'-17' - AL                |  | 10-1/2                         | R    | 11    | 3     |            | <b>992503</b> |
| 13'-16' - LL                |  | 10-1/8                         | R    | 12    | 3     |            | <b>992504</b> |
| 13'-16' - LL                |  | 10-1/8                         | R    | 13    | 3     |            | <b>992505</b> |
| 13'-16' - LL                |  | 10-1/8                         | R    | 14    | 3     |            | <b>992506</b> |

Drop-In Hub  
Use XHS® or XHS II® Hub Kit  
**123**  
OR  
**223**  
**⚠**



**022001**  
**022003**

|                             |  | <b>MATCH</b><br>MICHIGAN |      |        |       |                 |               |
|-----------------------------|--|--------------------------|------|--------|-------|-----------------|---------------|
|                             |  | ALUMINUM PROPELLERS      |      |        |       |                 |               |
| Boat Description/<br>Length |  | Dia.                     | Rot. | Pitch  | Bld # | OEM Part #      | Part #        |
| 16'-18' - AL                |  | 9-7/8                    | R    | 9      | 3     | 664-45941-01-00 | <b>022001</b> |
| 15'-17' - AL                |  | 9-7/8                    | R    | 10-1/2 | 3     | 664-45945-00-00 | <b>022002</b> |
| 14'-16' - AL                |  | 9-7/8                    | R    | 11-1/4 | 3     | 664-45947-10-00 | <b>022004</b> |
| 13'-16' - LL                |  | 9-7/8                    | R    | 12     | 3     | 664-45954-01-00 | <b>022003</b> |
| 13'-16' - LL                |  | 9-7/8                    | R    | 13     | 3     | 664-45949-02-00 | <b>022005</b> |
| Up to 15' - LL              |  | 9-7/8                    | R    | 14     | 3     | 664-45952-00-00 | <b>022006</b> |
| Up to 15' - LL              |  |                          |      |        |       |                 |               |

Rubber Hub Bushing  
Part # 65-265

|                             |  | <b>BALLISTIC</b><br>MICHIGAN          |      |       |       |            |                 |
|-----------------------------|--|---------------------------------------|------|-------|-------|------------|-----------------|
|                             |  | STAINLESS STEEL - E SERIES PROPELLERS |      |       |       |            |                 |
| Boat Description/<br>Length |  | Dia.                                  | Rot. | Pitch | Bld # | OEM Part # | Part #          |
|                             |  |                                       |      |       |       |            |                 |
|                             |  |                                       |      |       |       |            |                 |
|                             |  |                                       |      |       |       |            |                 |
|                             |  | 10-1/8                                | R    | 13    | 3     |            | * <b>933013</b> |
|                             |  |                                       |      |       |       |            |                 |
|                             |  | 10-1/8                                | R    | 15    | 3     |            | * <b>933015</b> |

Drop-In Hub  
Use XHS® or XHS II® Hub Kit  
**123**  
OR  
**223**  
**⚠**

Note: \* May interfere with trim tab.

15-60 HORSEPOWER • 3-1/2" GEARCASE

Thru Hub Exhaust & 13 Tooth Spline

Parsun® T35.....All Years

Parsun®T40.....All Years

Selva® 15 XS EFI (Aruana) .....2014 & Newer

Selva® 30 XS (Dorado) .....2014 & Newer

Selva® 60 EFI (Dorado).....2014 & Newer

Selva® 20 XS (Dorado) .....2014 & Newer

Selva® 40 EFI (Aruana) .....2014 & Newer

Selva® 60XSR EFI (Dorado) ..2014 & Newer

Selva® 25 XS (Dorado) .....2014 & Newer

Selva® 50XSR (Dorado).....2014 & Newer

**VORTEX**  
MICHIGAN

**APOLLO**  
MICHIGAN

ALUMINUM - D SERIES PROPELLERS

STAINLESS STEEL - D SERIES PROPELLERS

| 3-BLADE |      |       |        | LG. DIAMETER 3-BLADE |      |       |        | 4-BLADE |      |       |        |
|---------|------|-------|--------|----------------------|------|-------|--------|---------|------|-------|--------|
| Dia.    | Rot. | Pitch | Part # | Dia.                 | Rot. | Pitch | Part # | Dia.    | Rot. | Pitch | Part # |
|         |      |       |        |                      |      |       |        | 11-1/2  | R    | 8     | 992401 |
|         |      |       |        | 12-1/4               | R    | 9     | 992601 | 11-1/2  | R    | 9     | 992402 |
|         |      |       |        | 11-3/4               | R    | 10    | 992602 | 11-1/2  | R    | 10    | 992403 |
| 10-3/8  | R    | 11    | 992404 | 11-5/8               | R    | 11    | 992603 | 4-BLADE |      |       |        |
| 10-3/8  | R    | 12    | 992405 | 11-3/8               | R    | 12    | 992604 | 10-5/8  | R    | 12    | 941212 |
| 10-3/8  | R    | 13    | 992406 | 11-1/8               | R    | 13    | 992605 | 10-3/8  | R    | 13    | 941213 |
| 10-3/8  | R    | 14    | 992407 | 11-1/4               | R    | 14    | 992606 | 10-1/8  | R    | 14    | 941214 |
| 10      | R    | 15    | 992408 |                      |      |       |        | 10-1/8  | R    | 15    | 941215 |
| 10      | R    | 16    | 992409 |                      |      |       |        |         |      |       |        |

Drop-In Hub

Use XHS® or XHS II® Hub Kit

117 OR 217

Refer to Pages 55-57 for Details on Hub Kit Components.

Drop-In Hub

Use XHS® or XHS II® Hub Kit

117 OR 217

Refer to Pages 55-57 for Details on Hub Kit Components.

**MATCH**  
MICHIGAN

**BALLISTIC**  
MICHIGAN

ALUMINUM PROPELLERS

STAINLESS STEEL - D SERIES PROPELLERS

| Boat Description/<br>Length | Dia.          | Rot.   | Pitch | Bld # | OEM Part #      | Part #          |
|-----------------------------|---------------|--------|-------|-------|-----------------|-----------------|
|                             | 18' & Up - HL | 12-1/4 | R     | 9     | 3               | 663-45956-01-00 |
| 17' & Up - HL               | 11-3/4        | R      | 10    | 3     |                 | 032045          |
| 16'-18' - AL, SK            | 11-5/8        | R      | 11    | 3     | 69W-45947-00-00 | 032044          |
| 15'-17' - CUPPED            | 10-5/8        | R      | 12    | 3     | 6H5-45952-00-00 | 031074          |
| 15'-17' - AL, SK            | 11-3/8        | R      | 12    | 3     | 69W-45952-00-00 | 032043          |
| 14'-17' - CUPPED            | 10-3/8        | R      | 13    | 3     | 6H5-45945-00-00 | 031075          |
| 14'-17' - AL, SK            | 11-1/8        | R      | 13    | 3     | 69W-45945-00-00 | 032042          |
| 14'-16' - CUPPED            | 10-1/4        | R      | 14    |       | 6H5-45958-00-00 | 031076          |
| 14'-16' - LL                | 11-1/4        | R      | 14    | 3     | 69W-45958-00-00 | 032041          |
| 12'-14' - LL                | 11            | R      | 15    | 3     | 69W-45943-00-00 | 032040          |

Rubber Hub Bushing Part # 65-205

Drop-In Hub

Use XHS® or XHS II® Hub Kit

117 OR 217

Refer to Pages 55-57 for Details on Hub Kit Components.

| Dia.   | Rot. | Pitch | Bld # | OEM Part # | Part # |
|--------|------|-------|-------|------------|--------|
|        |      |       |       |            |        |
|        |      |       |       |            |        |
|        |      |       |       |            |        |
| 10-1/8 | R    | 13    | 3     |            | 933213 |
|        |      |       |       |            |        |
| 10-1/8 | R    | 15    | 3     |            | 933215 |

**30-115 HORSEPOWER • 4-1/4" GEARCASE**  
 Thru Hub Exhaust & 15 Tooth Spline • Replaces Yamaha® "K" Series Propellers

|                                       |  |  |
|---------------------------------------|--|--|
| Parsun® T60.....All Years             | Parsun® T85.....All Years                  | Parsun® T90.....All Years                |
| Parsun® T75.....All Years             |  |  |
| Selva® 30XS (Marlin).....2014 & Newer | Selva® 50XS (Marlin).....2014 & Newer      | Selva® 80XS (Marlin).....2014 & Newer    |
| Selva® 40XS (Marlin).....2014 & Newer | Selva® 50XS (Murena).....2014 & Newer      | Selva® 100 XS (Marlin).....2014 & Newer  |
| Selva® 40XS (Tarpon).....2014 & Newer | Selva® 70XSR EFI (Murena).....2014 & Newer | Selva® 115 EFI (Tarpon).....2014 & Newer |

| VORTEX<br>MICHIGAN       |      |       |                          |        |                      |
|--------------------------|------|-------|--------------------------|--------|----------------------|
| 3-BL ALUMINUM - B SERIES |      |       | 4-BL ALUMINUM - B SERIES |        |                      |
| Dia.                     | Rot. | Pitch | Bld #                    | Part # |                      |
| 14                       | R    | 10    | 3                        | 992109 |                      |
| 14                       | R    | 11    | 3                        | 992111 | 13-7/8 R 11 4 941411 |
| 14                       | R    | 13    | 3                        | 992112 | 13-7/8 R 13 4 941413 |
| 13-3/4                   | R    | 15    | 3                        | 992113 | 13-3/8 R 15 4 941415 |
| 13-1/4                   | R    | 17    | 3                        | 992114 | 13 R 17 4 941417     |
| 13                       | R    | 19    | 3                        | 992115 | 12-1/2 R 19 4 941419 |
| 12-3/4                   | R    | 21    | 3                        | 992116 |                      |

**Drop-In Hub**  
 Use XHS II® Hub Kit  
**203 / 208**  
 USE Gearcase Adapter Ring supplied with propeller.  
 Refer to Pages 55-57 for Details on Hub Kit Components.

| APOLLO<br>MICHIGAN                    |      |       |       |                 |          |
|---------------------------------------|------|-------|-------|-----------------|----------|
| STAINLESS STEEL - B SERIES PROPELLERS |      |       |       |                 |          |
| Dia.                                  | Rot. | Pitch | Bld # | OEM Part #      | Part #   |
| 13-3/8                                | R    | 15    | 3     |                 | ✳ 993143 |
| 13-3/8                                | L    | 15    | 3     |                 | ✳ 993153 |
| 13-1/4                                | R    | 17    | 3     | 688-45930-02-00 | ✳ 993144 |
| 13-1/4                                | L    | 17    | 3     | 6L6-45930-01-00 | ✳ 993154 |
| 13-1/8                                | R    | 19    | 3     | 688-45970-03-00 | ✳ 993145 |
| 13-1/8                                | L    | 19    | 3     | 6L6-45970-00-00 | ✳ 993155 |
| 13                                    | R    | 21    | 3     | 688-45972-02-00 | ✳ 993146 |
| 13                                    | L    | 21    | 3     | 6L6-45972-00-00 | ✳ 993156 |

**Drop-In Hub**  
 Use XHS II® Hub Kit  
**203 / 208**  
 USE Gearcase Adapter Ring supplied with propeller.  
 Refer to Pages 55-57 for Details on Hub Kit Components.

| Boat Description/Length | MATCH<br>MICHIGAN   |      |       |       |                 |        |
|-------------------------|---------------------|------|-------|-------|-----------------|--------|
|                         | ALUMINUM PROPELLERS |      |       |       |                 |        |
|                         | Dia.                | Rot. | Pitch | Bld # | OEM Part #      | Part # |
| 25' & Up                | 14                  | R    | 11    | 3     |                 | 101036 |
| 22'-25' - AL            | 13-5/8              | R    | 13    | 3     | 6E5-45949-00-00 | 101031 |
| 20'-24' - AL            | 13-1/2              | R    | 15    | 3     | 6E5-45947-00-00 | 101032 |
| 17'-19' - AL            | 13-1/4              | R    | 17    | 3     | 6E5-45945-01-00 | 101033 |
| 16'-18' - AL            | 13                  | R    | 19    | 3     | 6E5-45941-00-00 | 101034 |
| 15'-18' - AL            | 12-5/8              | R    | 21    | 3     |                 | 101035 |
| High Performance        |                     |      |       |       |                 |        |
| High Performance        |                     |      |       |       |                 |        |

**Rubber Hub Bushing**  
 Part # 65-441

| BALLISTIC<br>MICHIGAN                 |      |       |       |          |                      |      |       |       |          |
|---------------------------------------|------|-------|-------|----------|----------------------|------|-------|-------|----------|
| STAINLESS STEEL - B SERIES PROPELLERS |      |       |       |          |                      |      |       |       |          |
| 3-BLADE BALLISTIC                     |      |       |       |          | 3-BLADE BALLISTIC XL |      |       |       |          |
| Dia.                                  | Rot. | Pitch | Bld # | Part #   | Dia.                 | Rot. | Pitch | Bld # | Part #   |
| 13-5/8                                | R    | 15    | 3     | 933415   |                      |      |       |       |          |
| 13-1/2                                | R    | 17    | 3     | 933417   |                      |      |       |       |          |
| 13-3/8                                | R    | 19    | 3     | 933419   |                      |      |       |       |          |
| 13-1/8                                | R    | 21    | 3     | ✳ 933421 |                      |      |       |       |          |
|                                       |      |       |       |          | 13-1/2               | R    | 22    | 3     | ✳ 953422 |
|                                       |      |       |       |          | 13-1/2               | R    | 24    | 3     | ✳ 953424 |

**Drop-In Hub**  
 Use XHS II® Hub Kit  
**203 / 208**  
 USE Gearcase Adapter Ring supplied with propeller.  
 Refer to Pages 55-57 for Details on Hub Kit Components.

Note: For 115 HP use XHS II® (Drop-In Hub) Kit #203.  
 For all other engine applications use XHS II® (Drop-In Hub) Kit #208.

Note: ✳ Michigan Wheel high performance trim tab P/N 990341 is required when using stainless steel propellers.

**150-250 HORSEPOWER • 4-3/4" GEARCASE**

Thru Hub Exhaust & 15 Tooth Spline • Replaces Yamaha® "M" or "T" Series Propellers

Selva® 150XSR EFI (Killer Whale)..2014 & Newer  
Selva® 150 EFI (Killer Whale).....2014 & Newer

Selva® 200 EFI (Grey Whale) .....2014 & Newer  
Selva® 225 EFI (Fin Whale).....2014 & Newer

Selva® 250 EFI (Blue Whale)..2014 & Newer

**VORTEX**  
MICHIGAN

**APOLLO**  
MICHIGAN

| 3-BL ALUMINUM - A SERIES |      |       |       |        | 4-BL ALUMINUM - A SERIES |      |       |       |        |
|--------------------------|------|-------|-------|--------|--------------------------|------|-------|-------|--------|
| Dia.                     | Rot. | Pitch | Bld # | Part # | Dia.                     | Rot. | Pitch | Bld # | Part # |
| 16                       | R    | 13    | 3     | 992001 |                          |      |       |       |        |
| 15-1/4                   | R    | 15    | 3     | 992002 |                          |      |       |       |        |
| 16                       | R    | 16    | 3     | 931516 |                          |      |       |       |        |
| 15                       | R    | 17    | 3     | 992003 | 15                       | R    | 16    | 4     | 992202 |
|                          |      |       |       |        |                          |      |       |       |        |
| 14-1/2                   | R    | 19    | 3     | 992004 | 14-1/2                   | R    | 18    | 4     | 992203 |
|                          |      |       |       |        |                          |      |       |       |        |
| 14-1/4                   | R    | 21    | 3     | 992005 | 14                       | R    | 20    | 4     | 992204 |
|                          |      |       |       |        |                          |      |       |       |        |
| 14                       | R    | 23    | 3     | 992006 |                          |      |       |       |        |

Drop-In Hub

Use XHS II® Hub Kit

**203**

Refer to Pages 55-57 for Details on Hub Kit Components.

| STD. 3-BLADE A SERIES |      |       |        | LG DIA. 3-BLADE A SERIES |      |       |        | 4-BLADE A SERIES |      |       |        |
|-----------------------|------|-------|--------|--------------------------|------|-------|--------|------------------|------|-------|--------|
| Dia.                  | Rot. | Pitch | Part # | Dia.                     | Rot. | Pitch | Part # | Dia.             | Rot. | Pitch | Part # |
| 14-3/8                | R    | 15    | 993042 |                          |      |       |        |                  |      |       |        |
| 14-3/8                | L    | 15    | 993052 |                          |      |       |        |                  |      |       |        |
| 14-1/4                | R    | 17    | 993043 | 15-1/2                   | R    | 17    | 993023 | 14-5/8           | R    | 16    | 993203 |
| 14-1/4                | L    | 17    | 993053 | 15-1/2                   | L    | 17    | 993033 | 14-5/8           | L    | 16    | 993213 |
| 14-1/8                | R    | 19    | 993044 | 15-1/4                   | R    | 19    | 993024 | 14-3/8           | R    | 18    | 993204 |
| 14-1/8                | L    | 19    | 993054 | 15-1/4                   | L    | 19    | 993034 | 14-3/8           | L    | 18    | 993214 |
| 14                    | R    | 21    | 993045 | 14-3/4                   | R    | 21    | 993025 | 14-1/8           | R    | 20    | 993205 |
| 14                    | L    | 21    | 993055 | 14-3/4                   | L    | 21    | 993035 | 14-1/8           | L    | 20    | 993215 |
| 13-7/8                | R    | 23    | 993046 | 14-5/8                   | R    | 23    | 993026 | 14               | R    | 22    | 993206 |
| 13-7/8                | L    | 23    | 993056 | 14-5/8                   | L    | 23    | 993036 | 14               | L    | 22    | 993216 |

Drop-In Hub

Use XHS II® Hub Kit

**203**

Refer to Pages 55-57 for Details on Hub Kit Components.

**MATCH**  
MICHIGAN

**BALLISTIC**  
MICHIGAN

| Boat Description/<br>Length | ALUMINUM PROPELLERS |      |       |       |                 |        |
|-----------------------------|---------------------|------|-------|-------|-----------------|--------|
|                             | Dia.                | Rot. | Pitch | Bld # | OEM Part #      | Part # |
| 20'-22' - AL, SK            | 15-1/4              | R    | 15    | 3     | 6G5-45941-00-00 | 101025 |
| 19'-21' - AL, SK            | 14-1/2              | R    | 17    | 3     | 6G5-45947-01-00 | 101027 |
| 19'-21' - AL, SK            |                     |      |       |       |                 |        |
| 18'-20' - AL, SK            | 14                  | R    | 19    | 3     | 6G5-45945-01-00 | 101028 |
| 18'-20' - AL, SK            |                     |      |       |       |                 |        |
| 18'-20' - AL, SK            | 13-3/4              | R    | 21    | 3     | 6G5-45943-01-00 | 101029 |
| 18'-20' - AL, SK            |                     |      |       |       |                 |        |
| Up to 18' - AL, SK          |                     |      |       |       |                 |        |
| Up to 18' - AL, SK          |                     |      |       |       |                 |        |
| Up to 18' - AL, SK          |                     |      |       |       |                 |        |
| High Performance            |                     |      |       |       |                 |        |
| High Performance            |                     |      |       |       |                 |        |
| High Performance            |                     |      |       |       |                 |        |
| High Performance            |                     |      |       |       |                 |        |
| High Performance            |                     |      |       |       |                 |        |
| High Performance            |                     |      |       |       |                 |        |
| High Performance            |                     |      |       |       |                 |        |

Rubber Hub Bushing Part # 65-441

| STAINLESS STEEL - A SERIES PROPELLERS |      |       |       |        |                      |                      |       |       |        |  |
|---------------------------------------|------|-------|-------|--------|----------------------|----------------------|-------|-------|--------|--|
| 3-BLADE BALLISTIC                     |      |       |       |        |                      | 3-BLADE BALLISTIC XL |       |       |        |  |
| Dia.                                  | Rot. | Pitch | Bld # | Part # | Dia.                 | Rot.                 | Pitch | Bld # | Part # |  |
| 14-7/8                                | R    | 15    | 3     | 933515 |                      |                      |       |       |        |  |
| 14-3/4                                | R    | 17    | 3     | 933517 |                      |                      |       |       |        |  |
| 14-3/4                                | L    | 17    | 3     | 937517 |                      |                      |       |       |        |  |
| 14-1/2                                | R    | 19    | 3     | 933519 |                      |                      |       |       |        |  |
| 14-1/2                                | L    | 19    | 3     | 937519 |                      |                      |       |       |        |  |
| 14-3/8                                | R    | 21    | 3     | 933521 |                      |                      |       |       |        |  |
| 14-3/8                                | L    | 21    | 3     | 937521 |                      |                      |       |       |        |  |
| 14-1/4                                | R    | 23    | 3     | 933523 |                      |                      |       |       |        |  |
| 14-1/4                                | L    | 23    | 3     | 937523 |                      |                      |       |       |        |  |
| 14-1/4                                | R    | 25    | 3     | 933525 |                      |                      |       |       |        |  |
|                                       |      |       |       |        | 14-3/4               | R                    | 22    | 3     | 953522 |  |
|                                       |      |       |       |        | 14-3/4               | R                    | 24    | 3     | 953524 |  |
|                                       |      |       |       |        | 14-3/4               | R                    | 26    | 3     | 953526 |  |
|                                       |      |       |       |        | 4-BLADE BALLISTIC XL |                      |       |       |        |  |
|                                       |      |       |       |        | 14-1/8               | R                    | 23    | 4     | 963523 |  |
|                                       |      |       |       |        | 14-1/8               | R                    | 25    | 4     | 963525 |  |
|                                       |      |       |       |        | 14-1/8               | R                    | 27    | 4     | 963527 |  |



⊗ May interfere with trim tab.

Drop-In Hub

Use XHS II® Hub Kit

**203**

Refer to Pages 55-57 for Details on Hub Kit Components.

# MERCURISER®, ALPHA ONE™, BRAVO ONE™ • 4-3/4" GEARCASE

Thru Hub Exhaust & 15 Tooth Spline

MODELS 1A, 1B, 1C.....Thru 1982  
 MODELS 120, 140, 145 DTS.....Thru 1982  
 MODELS 165, 228, 470, 485, 888, 898 ... Thru 1982  
 MODELS 225S, 233, 255TRS.....Thru 1982  
 MODELS 260, 280TRS, 330TRS .....Thru 1982  
 120-190 HP Mercruiser®.....1983-1985  
 200-260 HP Mercruiser®.....1983-1985

**Alpha One™**  
 2.5L - 5.7L Alpha One™  
 6.2L MPI Alpha One™  
 262, 350, 454 Magnum  
 320 EFI Alpha One™

All Years  
 All Years  
 All Years  
 All Years

**Bravo One™** (Bravo One™ & Bravo One™ X Drives only.)  
 320 EFI, 350, 377 .....All Years  
 5.0L - 7.4L Bravo One™ .....All Years  
 D2.8L - D7.3L (Diesel).....All Years

\*For engines 300 HP or higher, use "High Horsepower Sleeve" (P/N 991372). See Page 48 for more details.

| VORTEX<br>MICHIGAN       |      |       |       |        | 4-BL ALUMINUM - A SERIES |      |       |            |
|--------------------------|------|-------|-------|--------|--------------------------|------|-------|------------|
| 3-BL ALUMINUM - A SERIES |      |       |       |        | 4-BL ALUMINUM - A SERIES |      |       |            |
| Dia.                     | Rot. | Pitch | Bld # | Part # | Dia.                     | Rot. | Pitch | Part #     |
| 16                       | R    | 13    | 3     | 992001 |                          |      |       |            |
| 15-1/4                   | R    | 15    | 3     | 992002 |                          |      |       |            |
| 16                       | R    | 16    | 3     | 931516 |                          |      |       |            |
| 15                       | R    | 17    | 3     | 992003 | 15                       | R    | 16    | 4 992202   |
|                          |      |       |       |        |                          |      |       |            |
| 14-1/2                   | R    | 19    | 3     | 992004 | 14-1/2                   | R    | 18    | 4 992203   |
|                          |      |       |       |        |                          |      |       |            |
| 14-1/4                   | R    | 21    | 3     | 992005 | 14                       | R    | 20    | 4 * 992204 |
|                          |      |       |       |        |                          |      |       |            |
| 14                       | R    | 23    | 3     | 992006 |                          |      |       |            |

**Drop-In Hub**  
 Use XHS II® Hub Kit  
**202**  
 Refer to Pages 55-57 for Details on Hub Kit Components.

| APOLLO<br>MICHIGAN    |      |       |          |                          |      |       |          |                  |      |       |          |
|-----------------------|------|-------|----------|--------------------------|------|-------|----------|------------------|------|-------|----------|
| STD. 3-BLADE A SERIES |      |       |          | LG DIA. 3-BLADE A SERIES |      |       |          | 4-BLADE A SERIES |      |       |          |
| Dia.                  | Rot. | Pitch | Part #   | Dia.                     | Rot. | Pitch | Part #   | Dia.             | Rot. | Pitch | Part #   |
| 14-3/8                | R    | 15    | * 993042 |                          |      |       |          |                  |      |       |          |
| 14-3/8                | L    | 15    | * 993052 |                          |      |       |          |                  |      |       |          |
| 14-1/4                | R    | 17    | * 993043 | 15-1/2                   | R    | 17    | ⊖ 993023 | 14-5/8           | R    | 16    | * 993203 |
| 14-1/4                | L    | 17    | * 993053 | 15-1/2                   | L    | 17    | ⊖ 993033 | 14-5/8           | L    | 16    | * 993213 |
| 14-1/8                | R    | 19    | * 993044 | 15-1/4                   | R    | 19    | ⊖ 993024 | 14-3/8           | R    | 18    | * 993204 |
| 14-1/8                | L    | 19    | * 993054 | 15-1/4                   | L    | 19    | ⊖ 993034 | 14-3/8           | L    | 18    | * 993214 |
| 14                    | R    | 21    | ⊖ 993045 | 14-3/4                   | R    | 21    | ⊖ 993025 | 14-1/8           | R    | 20    | * 993205 |
| 14                    | L    | 21    | ⊖ 993055 | 14-3/4                   | L    | 21    | ⊖ 993035 | 14-1/8           | L    | 20    | * 993215 |
| 13-7/8                | R    | 23    | ⊖ 993046 | 14-5/8                   | R    | 23    | ⊖ 993026 | 14               | R    | 22    | * 993206 |
| 13-7/8                | L    | 23    | ⊖ 993056 | 14-5/8                   | L    | 23    | ⊖ 993036 | 14               | L    | 22    | * 993216 |

**Drop-In Hub**  
 Use XHS II® Hub Kit  
**202**  
 Refer to Pages 55-57 for Details on Hub Kit Components.

| Boat Description/<br>Length | MATCH<br>MICHIGAN   |      |       |       |              |        |
|-----------------------------|---------------------|------|-------|-------|--------------|--------|
|                             | ALUMINUM PROPELLERS |      |       |       |              |        |
|                             | Dia.                | Rot. | Pitch | Bld # | OEM Part #   | Part # |
| CR, HB                      | 16                  | R    | 13    | 3     | 48-78114A45  | 031513 |
| 21'-24' - AL                | 15-1/4              | R    | 15    | 3     | 48-78116A45  | 031023 |
| 20'-23' - AL, SK            | 16                  | R    | 16    | 3     | 48-16440A45  | 031516 |
| 19'-23' - AL, SK            | 14-1/2              | R    | 17    | 3     | 48-78118A40  | 031024 |
| 19'-23' - AL, SK            | 15                  | R    | 17    | 3     | 48-832828A45 | 031064 |
| 19'-22' - AL, SK            | 15-1/2              | R    | 18    | 3     | 48-11324A45  | 031052 |
| 18'-22' - AL, SK            | 14                  | R    | 19    | 3     | 48-78120A40  | 031025 |
| 18'-22' - AI, SK            | 14-1/2              | R    | 19    | 3     | 48-832830A45 | 031065 |
| 18'-20' - AL, SK            | 13-3/4              | R    | 21    | 3     | 48-78122A40  | 031026 |
| 18'-20' - AL, SK            | 14-1/4              | R    | 21    | 3     | 48-832832A45 | 031066 |
| 17'-20' - AL, SK            |                     |      |       |       |              |        |
| 17'-20' - AL, SK            |                     |      |       |       |              |        |
| Up to 18'                   |                     |      |       |       |              |        |
| High Performance            |                     |      |       |       |              |        |
| High Performance            |                     |      |       |       |              |        |
| High Performance            |                     |      |       |       |              |        |
| High Performance            |                     |      |       |       |              |        |
| High Performance            |                     |      |       |       |              |        |
| High Performance            |                     |      |       |       |              |        |

**Rubber Hub Bushing**  
 Part # 65-322  
 Use MWM Kit 990312 (Conductivity Washer, Aft Washer) or MWM Kit 9661-1 (Fwd Washer, Conductivity Washer, Aft Washer, Tab Washer, Propeller Nut)  
 See Page 24 for details.

| BALLISTIC<br>MICHIGAN                 |      |       |       |          |                      |      |       |       |          |
|---------------------------------------|------|-------|-------|----------|----------------------|------|-------|-------|----------|
| STAINLESS STEEL - A SERIES PROPELLERS |      |       |       |          |                      |      |       |       |          |
| 3-BLADE BALLISTIC                     |      |       |       |          | 3-BLADE BALLISTIC XL |      |       |       |          |
| Dia.                                  | Rot. | Pitch | Bld # | Part #   | Dia.                 | Rot. | Pitch | Bld # | Part #   |
| 14-7/8                                | R    | 15    | 3     | * 933515 |                      |      |       |       |          |
| 14-3/4                                | R    | 17    | 3     | * 933517 |                      |      |       |       |          |
| 14-3/4                                | L    | 17    | 3     | * 937517 |                      |      |       |       |          |
| 14-1/2                                | R    | 19    | 3     | * 933519 |                      |      |       |       |          |
| 14-1/2                                | L    | 19    | 3     | * 937519 |                      |      |       |       |          |
| 14-3/8                                | R    | 21    | 3     | * 933521 |                      |      |       |       |          |
| 14-3/8                                | L    | 21    | 3     | * 937521 |                      |      |       |       |          |
| 14-1/4                                | R    | 23    | 3     | * 933523 |                      |      |       |       |          |
| 14-1/4                                | L    | 23    | 3     | * 937523 |                      |      |       |       |          |
| 14-1/4                                | R    | 25    | 3     | * 933525 |                      |      |       |       |          |
|                                       |      |       |       |          | 14-3/4               | R    | 22    | 3     | * 953522 |
|                                       |      |       |       |          | 14-3/4               | R    | 24    | 3     | * 953524 |
|                                       |      |       |       |          | 14-3/4               | R    | 26    | 3     | * 953526 |
| 4-BLADE BALLISTIC XL                  |      |       |       |          |                      |      |       |       |          |
|                                       |      |       |       |          | 14-1/8               | R    | 23    | 4     | * 963523 |
|                                       |      |       |       |          | 14-1/8               | R    | 25    | 4     | * 963525 |
|                                       |      |       |       |          | 14-1/8               | R    | 27    | 4     | * 963527 |

**Drop-In Hub**  
 Use XHS II® Hub Kit  
**202**  
 Refer to Pages 55-57 for Details on Hub Kit Components.



**Note:** \* Replace standard trim tab with Michigan Wheel trim tab P/N 990404.  
 ⊖ These applications will require Michigan Wheel anode plate P/N 990405.

**BRAVO ONE™ • OVER 365 HP • (SOLID HUB) • 4-3/4" GEARCASE**

Thru Hub Exhaust & 15 Tooth Spline

454 Magnum (385 HP) .....1995 & Newer  
496 Magnum (375 HP) .....All Years

496 Magnum H.O. (425 HP) .....All Years  
502 Magnum (390-415 HP) .....1990 & Newer

450 HP .....1995  
465 HP .....1991 & 1994



**APOLLO**  
MICHIGAN

| STD. 3-BLADE A SERIES |      |       |          | LG DIA. 3-BLADE A SERIES |      |       |        | 4-BLADE A SERIES |      |       |          |
|-----------------------|------|-------|----------|--------------------------|------|-------|--------|------------------|------|-------|----------|
| Dia.                  | Rot. | Pitch | Part #   | Dia.                     | Rot. | Pitch | Part # | Dia.             | Rot. | Pitch | Part #   |
| 14-3/8                | R    | 15    | * 993042 |                          |      |       |        |                  |      |       |          |
| 14-3/8                | L    | 15    | * 993052 |                          |      |       |        |                  |      |       |          |
| 14-1/4                | R    | 17    | * 993043 | 15-1/2                   | R    | 17    | 993023 | 14-5/8           | R    | 16    | * 993203 |
| 14-1/4                | L    | 17    | * 993053 | 15-1/2                   | L    | 17    | 993033 | 14-5/8           | L    | 16    | * 993213 |
| 14-1/8                | R    | 19    | * 993044 | 15-1/4                   | R    | 19    | 993024 | 14-3/8           | R    | 18    | * 993204 |
| 14-1/8                | L    | 19    | * 993054 | 15-1/4                   | L    | 19    | 993034 | 14-3/8           | L    | 18    | * 993214 |
| 14                    | R    | 21    | 993045   | 14-3/4                   | R    | 21    | 993025 | 14-1/8           | R    | 20    | * 993205 |
| 14                    | L    | 21    | 993055   | 14-3/4                   | L    | 21    | 993035 | 14-1/8           | L    | 20    | * 993215 |
| 13-7/8                | R    | 23    | 993046   | 14-5/8                   | R    | 23    | 993026 | 14               | R    | 22    | * 993206 |
| 13-7/8                | L    | 23    | 993056   | 14-5/8                   | L    | 23    | 993036 | 14               | L    | 22    | * 993216 |

Drop-In Hub

Use XHS II® Hub Kit

**202SH**

Refer to Pages 55-57 for Details on Hub Kit Components.



990404



990405

**BALLISTIC**  
MICHIGAN

STAINLESS STEEL - A SERIES PROPELLERS

| 3-BLADE BALLISTIC |      |       |       |          | 3-BLADE BALLISTIC XL |      |       |       |          |
|-------------------|------|-------|-------|----------|----------------------|------|-------|-------|----------|
| Dia.              | Rot. | Pitch | Bld # | Part #   | Dia.                 | Rot. | Pitch | Bld # | Part #   |
| 14-7/8            | R    | 15    | 3     | * 933515 |                      |      |       |       |          |
| 14-3/4            | R    | 17    | 3     | * 933517 |                      |      |       |       |          |
| 14-3/4            | L    | 17    | 3     | * 937517 |                      |      |       |       |          |
| 14-1/2            | R    | 19    | 3     | * 933519 |                      |      |       |       |          |
| 14-1/2            | L    | 19    | 3     | * 937519 |                      |      |       |       |          |
| 14-3/8            | R    | 21    | 3     | * 933521 |                      |      |       |       |          |
| 14-3/8            | L    | 21    | 3     | * 937521 |                      |      |       |       |          |
| 14-1/4            | R    | 23    | 3     | * 933523 |                      |      |       |       |          |
| 14-1/4            | L    | 23    | 3     | * 937523 |                      |      |       |       |          |
| 14-1/4            | R    | 25    | 3     | * 933525 |                      |      |       |       |          |
|                   |      |       |       |          | 14-3/4               | R    | 22    | 3     | * 953522 |
|                   |      |       |       |          | 14-3/4               | R    | 24    | 3     | * 953524 |
|                   |      |       |       |          | 14-3/4               | R    | 26    | 3     | * 953526 |

Drop-In Hub

Use XHS II® Hub Kit

**202SH**

Refer to Pages 55-57 for Details on Hub Kit Components.

Note: \* Replace standard trim tab with Michigan Wheel trim tab P/N 990404. These applications will require Michigan Wheel anode plate P/N 990405.

**BRAVO II™ • (BRAVO BRASS DRIVE) • 4-3/4" GEARCASE**

Thru Hub Exhaust & 19 Tooth Spline

4.3 L (155-250 HP) .....1996 & Newer  
5.7 L (210-300 HP) .....1993 & Newer

7.4 L (300-385 HP) .....1990 & Newer  
496 Magnum (375-425 HP) .....2001 & Newer

D2.8 L (150 HP) .....1997 & Newer  
D4.2 L (200-250 HP) .....1996 & Newer

**MATCH**  
MICHIGAN

| Boat Description/<br>Length | ALUMINUM PROPELLERS |      |       |       |             |               |
|-----------------------------|---------------------|------|-------|-------|-------------|---------------|
|                             | Dia.                | Rot. | Pitch | Bld # | OEM Part #  | Part #        |
| 28'- 32' (21-31 MPH)        | 18-3/4              | R    | 17    | 3     | 48-18612A40 | <b>081612</b> |
| 28'- 32' (21-31 MPH)        | 18-3/4              | L    | 17    | 3     | 48-18613A40 | <b>081613</b> |
| 26'- 30' (32-36 MPH)        | 18-1/4              | R    | 19    | 3     | 48-18614A40 | <b>081614</b> |
| 26'- 30' (32-36 MPH)        | 18-1/4              | L    | 19    | 3     | 48-18615A40 | <b>081615</b> |
| 25'- 28' (35-40 MPH)        | 17-3/4              | R    | 21    | 3     | 48-18616A40 | <b>081616</b> |
| 25'- 28' (35-40 MPH)        | 17-3/4              | L    | 21    | 3     | 48-18617A40 | <b>081617</b> |
| 24'- 27' (39-44 MPH)        | 17-1/2              | R    | 23    | 3     | 48-18618A40 | <b>081618</b> |
| 24'- 27' (39-44 MPH)        | 17-1/2              | L    | 23    | 3     | 48-18619A40 | <b>081619</b> |



031619

Rubber Hub Bushing

Note: Part numbers and availability may differ in European market.

## MODEL 400, COBRA® • 4-1/4" GEARCASE

Thru Hub Exhaust & 13 Tooth Spline

|                                |                                |
|--------------------------------|--------------------------------|
| Model 400                      | Cobra®                         |
| 2.3 L (120 HP) ..... Thru 1991 | 2.3 L (128 HP) ..... 1988-1991 |
| 2.5 L (120 HP) ..... 1978-1984 | 2.5 L (120 HP) ..... 1985-1987 |
| 3.0 L (140 HP) ..... Thru 1989 | 3.0 L (140 HP) ..... 1985-1987 |

| VORTEX<br>MICHIGAN       |      |       |                          |        |                      |
|--------------------------|------|-------|--------------------------|--------|----------------------|
| 3-BL ALUMINUM - B SERIES |      |       | 4-BL ALUMINUM - B SERIES |        |                      |
| Dia.                     | Rot. | Pitch | Bld #                    | Part # |                      |
| 14                       | R    | 10    | 3                        | 992109 |                      |
| 14                       | R    | 11    | 3                        | 992111 | 13-7/8 R 11 4 941411 |
| 14                       | R    | 13    | 3                        | 992112 | 13-7/8 R 13 4 941413 |
| 13-3/4                   | R    | 15    | 3                        | 992113 | 13-3/8 R 15 4 941415 |
|                          |      |       |                          |        |                      |
| 13-1/4                   | R    | 17    | 3                        | 992114 | 13 R 17 4 941417     |
|                          |      |       |                          |        |                      |
| 13                       | R    | 19    | 3                        | 992115 | 12-1/2 R 19 4 941419 |
|                          |      |       |                          |        |                      |
| 12-3/4                   | R    | 21    | 3                        | 992116 |                      |

**Drop-In Hub**

Use XHS II® Hub Kit

**206**

Do NOT use Gearcase Adapter Ring supplied with propeller.

Refer to Pages 55-57 for Details on Hub Kit Components.

| APOLLO<br>MICHIGAN                    |      |       |       |            |        |
|---------------------------------------|------|-------|-------|------------|--------|
| STAINLESS STEEL - B SERIES PROPELLERS |      |       |       |            |        |
| Dia.                                  | Rot. | Pitch | Bld # | OEM Part # | Part # |
|                                       |      |       |       |            |        |
|                                       |      |       |       |            |        |
| 13-3/8                                | R    | 15    | 3     |            | 993143 |
| 13-3/8                                | L    | 15    | 3     |            | 993153 |
| 13-1/4                                | R    | 17    | 3     |            | 993144 |
| 13-1/4                                | L    | 17    | 3     |            | 993154 |
| 13-1/8                                | R    | 19    | 3     |            | 993145 |
| 13-1/8                                | L    | 19    | 3     |            | 993155 |
| 13                                    | R    | 21    | 3     |            | 993146 |
| 13                                    | L    | 21    | 3     |            | 993156 |

**Drop-In Hub**

Use XHS II® Hub Kit

**206**

Do NOT use Gearcase Adapter Ring supplied with propeller.

Refer to Pages 55-57 for Details on Hub Kit Components.

| Boat Description/<br>Length | MATCH<br>MICHIGAN   |      |       |       |            |        |
|-----------------------------|---------------------|------|-------|-------|------------|--------|
|                             | ALUMINUM PROPELLERS |      |       |       |            |        |
|                             | Dia.                | Rot. | Pitch | Bld # | OEM Part # | Part # |
| CR, HB                      | 14                  | R    | 11    | 3     | 763301     | 012047 |
| 19'-22' - AL, SK            | 14                  | R    | 13    | 3     | 763302     | 011001 |
| 17'-19' - AL, SK            | 13-3/4              | R    | 15    | 3     | 763466     | 011002 |
| 15'-17' - AL, SK            | 13-1/4              | R    | 17    | 3     | 763463     | 011003 |
| 15'-17' - AL, SK            | 14                  | R    | 17    | 3     | 763463     | 011024 |
| 14'-16' - AL                | 13                  | R    | 19    | 3     | 763464     | 011004 |
| 14'-16' - AL, SK            | 14                  | R    | 19    | 3     | 763464     | 011025 |
| 13'-15' - AL, SK            | 12-3/4              | R    | 21    | 3     | 763465     | 011005 |
| 14'-16' - AL                | 13-1/4              | R    | 19    | 3     | 765184     | 011419 |

**Rubber Hub Bushing**

Part # 65-172

| BALLISTIC<br>MICHIGAN                 |      |       |       |            |        |
|---------------------------------------|------|-------|-------|------------|--------|
| STAINLESS STEEL - B SERIES PROPELLERS |      |       |       |            |        |
| Dia.                                  | Rot. | Pitch | Bld # | OEM Part # | Part # |
|                                       |      |       |       |            |        |
|                                       |      |       |       |            |        |
| 13-5/8                                | R    | 15    | 3     |            | 933415 |
| 13-1/2                                | R    | 17    | 3     |            | 933417 |
|                                       |      |       |       |            |        |
| 13-3/8                                | R    | 19    | 3     |            | 933419 |
|                                       |      |       |       |            |        |
| 13-1/8                                | R    | 21    | 3     |            | 933421 |

**Drop-In Hub**

Use XHS II® Hub Kit

**206**

Do NOT use Gearcase Adapter Ring supplied with propeller.

Refer to Pages 55-57 for Details on Hub Kit Components.

## SEA DRIVE® 1982 & NEWER • 4-1/4" GEARCASE

Thru Hub Exhaust & 13 Tooth Spline

|                              |                              |
|------------------------------|------------------------------|
| 1.6 L V-4 ..... 1982 & Newer | 1.8 L V-4 ..... 1987 & Newer |
|------------------------------|------------------------------|

For twin installations increase pitch 2".

| Boat Description/<br>Length | MATCH<br>MICHIGAN   |      |       |       |            |        |
|-----------------------------|---------------------|------|-------|-------|------------|--------|
|                             | ALUMINUM PROPELLERS |      |       |       |            |        |
|                             | Dia.                | Rot. | Pitch | Bld # | OEM Part # | Part # |
| CR, HB                      | 14                  | R    | 11    | 3     | 763301     | 012047 |
| 19'-22' - AL                | 14                  | R    | 13    | 3     | 763302     | 011001 |
| 17'-19' - AL                | 13-3/4              | R    | 15    | 3     | 763466     | 011002 |
| 15'-17' - AL                | 13-1/4              | R    | 17    | 3     | 763463     | 011003 |
| 15'-17' - AL, SK            | 14                  | R    | 17    | 3     | 763463     | 011024 |
| 14'-16' - AL                | 13                  | R    | 19    | 3     | 763464     | 011004 |
| 14'-16' - AL, SK            | 14                  | R    | 19    | 3     | 763464     | 011025 |
| 13'-15' - AL, SK            | 13                  | R    | 21    | 3     | 763465     | 011005 |



**Rubber Hub Bushing**

Part # 65-172

## MODEL 800, KING COBRA®, COBRA®, SEA DRIVE® • 4-3/4" GEARCASE

Thru Hub Exhaust & 15 Tooth Spline

|                               |                                     |   |
|-------------------------------|-------------------------------------|---|
| 3.0 L .....1990-1993          | 5.0 L ..... 1978-1993               | 7.4 L ..... 1990-1993                   |
| 3.2 L (Diesel) .....1992-1993 | 5.7 L ..... 1978-1993               | 7.5 L ..... 1987-1990                   |
| 3.8 L .....1978-1985          | 5.8 L (Cobra®) ..... 1989-1993      | 8.2 L ..... 1992-1993                   |
| 4.3 L .....1985-1993          | 5.8 L (King Cobra®) ..... 1992-1994 | Sea Drive® 2.0 L - 4.0 L .....All Years |

Includes H.O. and EFI Models

**Note: For SX Drive, see Volvo Penta section on Page 51.**

### VORTEX MICHIGAN

### APOLLO MICHIGAN

| 3-BL ALUMINUM - A SERIES |      |       |       |        | 4-BL ALUMINUM - A SERIES |      |       |       |        |
|--------------------------|------|-------|-------|--------|--------------------------|------|-------|-------|--------|
| Dia.                     | Rot. | Pitch | Bld # | Part # | Dia.                     | Rot. | Pitch | Bld # | Part # |
| 16                       | R    | 13    | 3     | 992001 |                          |      |       |       |        |
| 15-1/4                   | R    | 15    | 3     | 992002 |                          |      |       |       |        |
| 16                       | R    | 16    | 3     | 931516 |                          |      |       |       |        |
| 15                       | R    | 17    | 3     | 992003 | 15                       | R    | 16    | 4     | 992202 |
|                          |      |       |       |        |                          |      |       |       |        |
| 14-1/2                   | R    | 19    | 3     | 992004 | 14-1/2                   | R    | 18    | 4     | 992203 |
|                          |      |       |       |        |                          |      |       |       |        |
| 14-1/4                   | R    | 21    | 3     | 992005 | 14                       | R    | 20    | 4     | 992204 |
|                          |      |       |       |        |                          |      |       |       |        |
| 14                       | R    | 23    | 3     | 992006 |                          |      |       |       |        |

**Drop-In Hub**  
  
Use XHS II® Hub Kit **200 / 201**  
  
Refer to Pages 55-57 for Details on Hub Kit Components.

| STD. 3-BLADE A SERIES |      |       |        | LG DIA. 3-BLADE A SERIES |      |       |        | 4-BLADE A SERIES |      |       |        |
|-----------------------|------|-------|--------|--------------------------|------|-------|--------|------------------|------|-------|--------|
| Dia.                  | Rot. | Pitch | Part # | Dia.                     | Rot. | Pitch | Part # | Dia.             | Rot. | Pitch | Part # |
|                       |      |       |        |                          |      |       |        |                  |      |       |        |
| 14-3/8                | R    | 15    | 993042 |                          |      |       |        |                  |      |       |        |
| 14-3/8                | L    | 15    | 993052 |                          |      |       |        |                  |      |       |        |
| 14-1/4                | R    | 17    | 993043 | 15-1/2                   | R    | 17    | 993023 | 14-5/8           | R    | 16    | 993203 |
| 14-1/4                | L    | 17    | 993053 | 15-1/2                   | L    | 17    | 993033 | 14-5/8           | L    | 16    | 993213 |
| 14-1/8                | R    | 19    | 993044 | 15-1/4                   | R    | 19    | 993024 | 14-3/8           | R    | 18    | 993204 |
| 14-1/8                | L    | 19    | 993054 | 15-1/4                   | L    | 19    | 993034 | 14-3/8           | L    | 18    | 993214 |
| 14                    | R    | 21    | 993045 | 14-3/4                   | R    | 21    | 993025 | 14-1/8           | R    | 20    | 993205 |
| 14                    | L    | 21    | 993055 | 14-3/4                   | L    | 21    | 993035 | 14-1/8           | L    | 20    | 993215 |
| 13-7/8                | R    | 23    | 993046 | 14-5/8                   | R    | 23    | 993026 | 14               | R    | 22    | 993206 |
| 13-7/8                | L    | 23    | 993056 | 14-5/8                   | L    | 23    | 993036 | 14               | L    | 22    | 993216 |

**Drop-In Hub**  
  
Use XHS II® Hub Kit **200 / 201**  
  
Refer to Pages 55-57 for Details on Hub Kit Components.

### MATCH MICHIGAN

### BALLISTIC MICHIGAN

| Boat Description/<br>Length | ALUMINUM PROPELLERS |      |       |       |            |        |
|-----------------------------|---------------------|------|-------|-------|------------|--------|
|                             | Dia.                | Rot. | Pitch | Bld # | OEM Part # | Part # |
| Non-Plane Heavy CR          | 15-1/2              | R    | 13    | 3     | 763453     | 011016 |
| 22'-28' (22-32 MPH)         | 15-1/2              | R    | 15    | 3     | 763471     | 011006 |
| 19'-26' (28-39 MPH)         |                     |      |       |       |            |        |
| 18'-26' (30-46 MPH)         | 15                  | R    | 17    | 3     | 763467     | 011007 |
| 18'-26' (30-46 MPH)         |                     |      |       |       |            |        |
| 17'-24' (36-52 MPH)         | 14-1/2              | R    | 19    | 3     | 763468     | 011008 |
| 17'-24' (36-52 MPH)         |                     |      |       |       |            |        |
| 16'-22' (40-60 MPH)         | 14-1/4              | R    | 21    | 3     | 763469     | 011009 |
| 16'-22' (40-60 MPH)         |                     |      |       |       |            |        |
| 15'-20' (45-66 MPH)         |                     |      |       |       |            |        |
| 15'-20' (45-66 MPH)         |                     |      |       |       |            |        |
| Hi Perf. (50-66 MPH)        |                     |      |       |       |            |        |

**Rubber Hub Bushing**  
Part # 65-254

| STAINLESS STEEL - A SERIES PROPELLERS |      |       |       |            |        |
|---------------------------------------|------|-------|-------|------------|--------|
| Dia.                                  | Rot. | Pitch | Bld # | OEM Part # | Part # |
|                                       |      |       |       |            |        |
| 14-7/8                                | R    | 15    | 3     |            | 933515 |
| 14-3/4                                | R    | 17    | 3     |            | 933517 |
| 14-3/4                                | L    | 17    | 3     |            | 937517 |
| 14-1/2                                | R    | 19    | 3     |            | 933519 |
| 14-1/2                                | L    | 19    | 3     |            | 937519 |
| 14-3/8                                | R    | 21    | 3     |            | 933521 |
| 14-3/8                                | L    | 21    | 3     |            | 937521 |
| 14-1/4                                | R    | 23    | 3     |            | 933523 |
| 14-1/4                                | L    | 23    | 3     |            | 937523 |
| 14-1/4                                | R    | 25    | 3     |            | 933525 |

**Drop-In Hub**  
  
Use XHS II® Hub Kit **200 / 201**  
  
Refer to Pages 55-57 for Details on Hub Kit Components.

**Note:** For engine applications 1976-1990 use XHS II® (Drop-In Hub) Kit #201.  
For engine applications 1991 & Newer use XHS II® (Drop-In Hub) Kit #200.

## MODEL 14 LARGE GEARCASE 1967-1977

Non-Thru Hub Exhaust & Pin Drive

Suggestion: For twin installation increase pitch 2".  
HP Range: 100-245

| Boat Description/<br>Length | ALUMINUM PROPELLERS |      |       |       |            |        |
|-----------------------------|---------------------|------|-------|-------|------------|--------|
|                             | Dia.                | Rot. | Pitch | Bld # | OEM Part # | Part # |
| HP Range: 100-245           | 14                  | R    | 14    | 3     | 381185     | 012091 |
| HP Range: 100-245           | 14                  | R    | 16    | 3     | 381186     | 012092 |



012091

**Rubber Hub Bushing**  
Part # 65-156



## SX COBRA™, VOLVO PENTA SX • 4-3/4" GEARCASE

Thru Hub Exhaust & 19 Tooth Spline

|                        |                        |                        |
|------------------------|------------------------|------------------------|
| 3.0 L.....1994 & Newer | 5.7 L.....1994 & Newer | 7.4 L.....1997 & Newer |
| 4.3 L.....1994 & Newer | 5.8 L.....1994-1997    | 8.2 L.....1997         |
| 5.0 L.....1994 & Newer |                        |                        |

| VORTEX<br>MICHIGAN       |      |       |       |        | APOLLO<br>MICHIGAN       |      |       |       |        |             |                       |      |        |                          |      |      |                  |        |      |             |        |       |
|--------------------------|------|-------|-------|--------|--------------------------|------|-------|-------|--------|-------------|-----------------------|------|--------|--------------------------|------|------|------------------|--------|------|-------------|--------|-------|
| 3-BL ALUMINUM - A SERIES |      |       |       |        | 4-BL ALUMINUM - A SERIES |      |       |       |        | Drop-In Hub | STD. 3-BLADE A SERIES |      |        | LG DIA. 3-BLADE A SERIES |      |      | 4-BLADE A SERIES |        |      | Drop-In Hub |        |       |
| Dia.                     | Rot. | Pitch | Bld # | Part # | Dia.                     | Rot. | Pitch | Bld # | Part # |             | Dia.                  | Rot. | Pitch  | Part #                   | Dia. | Rot. | Pitch            | Part # | Dia. |             | Rot.   | Pitch |
| 16                       | R    | 13    | 3     | 992001 |                          |      |       |       |        | 14-3/8      | R                     | 15   | 993042 |                          |      |      |                  |        |      |             |        |       |
| 15-1/4                   | R    | 15    | 3     | 992002 |                          |      |       |       |        | 14-3/8      | L                     | 15   | 993052 |                          |      |      |                  |        |      |             |        |       |
| 16                       | R    | 16    | 3     | 931516 |                          |      |       |       |        | 14-1/4      | R                     | 17   | 993043 | 15-1/2                   | R    | 17   | 993023           | 14-5/8 | R    | 16          | 993203 |       |
| 15                       | R    | 17    | 3     | 992003 | 15                       | R    | 16    | 4     | 992202 | 14-1/4      | L                     | 17   | 993053 | 15-1/2                   | L    | 17   | 993033           | 14-5/8 | L    | 16          | 993213 |       |
| 14-1/2                   | R    | 19    | 3     | 992004 | 14-1/2                   | R    | 18    | 4     | 992203 | 14-1/8      | R                     | 19   | 993044 | 15-1/4                   | R    | 19   | 993024           | 14-3/8 | R    | 18          | 993204 |       |
| 14-1/4                   | R    | 21    | 3     | 992005 | 14                       | R    | 20    | 4     | 992204 | 14-1/8      | L                     | 19   | 993054 | 15-1/4                   | L    | 19   | 993034           | 14-3/8 | L    | 18          | 993214 |       |
| 14                       | R    | 23    | 3     | 992006 |                          |      |       |       |        | 14          | R                     | 21   | 993045 | 14-3/4                   | R    | 21   | 993025           | 14-1/8 | R    | 20          | 993205 |       |
|                          |      |       |       |        |                          |      |       |       |        | 14          | L                     | 21   | 993055 | 14-3/4                   | L    | 21   | 993035           | 14-1/8 | L    | 20          | 993215 |       |
|                          |      |       |       |        |                          |      |       |       |        | 13-7/8      | R                     | 23   | 993046 | 14-5/8                   | R    | 23   | 993026           | 14     | R    | 22          | 993206 |       |
|                          |      |       |       |        |                          |      |       |       |        | 13-7/8      | L                     | 23   | 993056 | 14-5/8                   | L    | 23   | 993036           | 14     | L    | 22          | 993216 |       |

**Drop-In Hub**  
Use XHS II® Hub Kit  
**205**  
Refer to Pages 55-57 for Details on Hub Kit Components.

**Drop-In Hub**  
Use XHS II® Hub Kit  
**205**  
Refer to Pages 55-57 for Details on Hub Kit Components.

| Boat Description/<br>Length | MATCH<br>MICHIGAN   |      |       |       |            |        | BALLISTIC<br>MICHIGAN                 |      |       |       |            |        |
|-----------------------------|---------------------|------|-------|-------|------------|--------|---------------------------------------|------|-------|-------|------------|--------|
|                             | ALUMINUM PROPELLERS |      |       |       |            |        | STAINLESS STEEL - A SERIES PROPELLERS |      |       |       |            |        |
|                             | Dia.                | Rot. | Pitch | Bld # | OEM Part # | Part # | Dia.                                  | Rot. | Pitch | Bld # | OEM Part # | Part # |
| 24'-25' (26-36 MPH)         | 15-1/2              | R    | 15    | 3     | 3850299    | 161001 | 14-7/8                                | R    | 15    | 3     |            | 933515 |
| 22'-27' (34-44 MPH)         | 15                  | R    | 17    | 3     | 3850300    | 161002 | 14-3/4                                | R    | 17    | 3     |            | 933517 |
| 22'-27' (33-44 MPH)         |                     |      |       |       |            |        | 14-3/4                                | L    | 17    | 3     |            | 937517 |
| 19'-25' (39-50 MPH)         | 14-1/2              | R    | 19    | 3     | 3850301    | 161003 | 14-1/2                                | R    | 19    | 3     |            | 933519 |
| 19'-25' (39-50 MPH)         |                     |      |       |       |            |        | 14-1/2                                | L    | 19    | 3     |            | 937519 |
| 17'-22' (39-50 MPH)         | 14-1/4              | R    | 21    | 3     | 3850302    | 161004 | 14-3/8                                | R    | 21    | 3     |            | 933521 |
| 17'-22' (39-50 MPH)         |                     |      |       |       |            |        | 14-3/8                                | L    | 21    | 3     |            | 937521 |
| 17'-20' (44-57 MPH)         | 14-1/4              | R    | 23    | 3     | 3850303    | 161005 | 14-1/4                                | R    | 23    | 3     |            | 933523 |
| 17'-20' (44-57 MPH)         |                     |      |       |       |            |        | 14-1/4                                | L    | 23    | 3     |            | 937523 |

**Rubber Hub Bushing**  
Part # 65-380

**Drop-In Hub**  
Use XHS II® Hub Kit  
**205**  
Refer to Pages 55-57 for Details on Hub Kit Components.

## **NEW** DUOPROP™ TYPE A & B • DP280, 290 DRIVES Gasoline and Diesel Engines

| Propeller Series    | MATCH<br>MICHIGAN |            | Image | Propeller Series  | MATCH<br>MICHIGAN |              |        |             | Image |  |
|---------------------|-------------------|------------|-------|---|-------------------|--------------|--------|-------------|-------|--|
|                     | OEM Part #        | Kit Part # |       |   | OEM               | Front Part # | OEM    | Rear Part # |       |  |
| Type A3             | 854766            | 085010     |       | Type B3   | 854824            | 086008       | 854832 | 086009      |       |  |
| Type A4             | 854767            | 085013     |       | Type B4   | 854825            | 086011       | 854833 | 086012      |       |  |
| Type A5             | 854768            | 085016     |       | Type B5   | 854826            | 086014       | 854834 | 086015      |       |  |
| Type A6             | 854769            | 085019     |       | Type B6   | 854827            | 086017       | 854835 | 086018      |       |  |
| Type A7             | 854770            | 085022     |       | Type B7   | 854828            | 086020       | 854836 | 086021      |       |  |
| ALUMINUM PROPELLERS |                   |            |       | <b>Note: Type B single propellers available only through Michigan Wheel US warehouse.</b> |                   |              |        |             |       |  |
| Type B3             | 854816            | 086007     |       |   |                   |              |        |             |       |  |
| Type B4             | 854817            | 086010     |       |   |                   |              |        |             |       |  |
| Type B5             | 854818            | 086013     |       |   |                   |              |        |             |       |  |
| Type B6             | 854819            | 086016     |       |   |                   |              |        |             |       |  |
| Type B7             | 854820            | 086019     |       |   |                   |              |        |             |       |  |

**Note: Type A & B propeller kits available only through Michigan Wheel UK warehouse.**

**YAMAHA STERNDRIVES • 4-3/4" GEARCASE**

Thru Hub Exhaust & 15 Tooth Spline

3.0 L (130 HP) EST/PSR .....1989-1993  
 4.3 L (205 HP) EST/PSR/YEMS 1989-1993

5.0 L (205 HP) EST/PSR/YEMS ..... 1989-1993  
 5.7 L (260 HP) EST/PSR/YEMS 1989-1993

7.4 L (300 HP\*) Hydra Drive EST ..... 1992-1993  
 \*For engines 300 HP or higher, use "High Horsepower Sleeve" (P/N 991372). See Page 48 for more details.

**VORTEX**  
MICHIGAN

**APOLLO**  
MICHIGAN

| 3-BL ALUMINUM - A SERIES |      |       |       |        | 4-BL ALUMINUM - A SERIES |      |       |       |        |
|--------------------------|------|-------|-------|--------|--------------------------|------|-------|-------|--------|
| Dia.                     | Rot. | Pitch | Bld # | Part # | Dia.                     | Rot. | Pitch | Bld # | Part # |
| 16                       | R    | 13    | 3     | 992001 |                          |      |       |       |        |
| 15-1/4                   | R    | 15    | 3     | 992002 |                          |      |       |       |        |
| 16                       | R    | 16    | 3     | 931516 |                          |      |       |       |        |
| 15                       | R    | 17    | 3     | 992003 | 15                       | R    | 16    | 4     | 992202 |
|                          |      |       |       |        |                          |      |       |       |        |
| 14-1/2                   | R    | 19    | 3     | 992004 | 14-1/2                   | R    | 18    | 4     | 992203 |
|                          |      |       |       |        |                          |      |       |       |        |
| 14-1/4                   | R    | 21    | 3     | 992005 | 14                       | R    | 20    | 4     | 992204 |
|                          |      |       |       |        |                          |      |       |       |        |
| 14                       | R    | 23    | 3     | 992006 |                          |      |       |       |        |

**Drop-In Hub**  
 Use XHS II® Hub Kit  
**203**  
 Refer to Pages 55-57 for Details on Hub Kit Components.

| STD. 3-BLADE A SERIES |      |       |        | LG DIA. 3-BLADE A SERIES |      |       |        | 4-BLADE A SERIES |      |       |        |
|-----------------------|------|-------|--------|--------------------------|------|-------|--------|------------------|------|-------|--------|
| Dia.                  | Rot. | Pitch | Part # | Dia.                     | Rot. | Pitch | Part # | Dia.             | Rot. | Pitch | Part # |
| 14-3/8                | R    | 15    | 993042 |                          |      |       |        |                  |      |       |        |
| 14-3/8                | L    | 15    | 993052 |                          |      |       |        |                  |      |       |        |
| 14-1/4                | R    | 17    | 993043 | 15-1/2                   | R    | 17    | 993023 | 14-5/8           | R    | 16    | 993203 |
| 14-1/4                | L    | 17    | 993053 | 15-1/2                   | L    | 17    | 993033 | 14-5/8           | L    | 16    | 993213 |
| 14-1/8                | R    | 19    | 993044 | 15-1/4                   | R    | 19    | 993024 | 14-3/8           | R    | 18    | 993204 |
| 14-1/8                | L    | 19    | 993054 | 15-1/4                   | L    | 19    | 993034 | 14-3/8           | L    | 18    | 993214 |
| 14                    | R    | 21    | 993045 | 14-3/4                   | R    | 21    | 993025 | 14-1/8           | R    | 20    | 993205 |
| 14                    | L    | 21    | 993055 | 14-3/4                   | L    | 21    | 993035 | 14-1/8           | L    | 20    | 993215 |
| 13-7/8                | R    | 23    | 993046 | 14-5/8                   | R    | 23    | 993026 | 14               | R    | 22    | 993206 |
| 13-7/8                | L    | 23    | 993056 | 14-5/8                   | L    | 23    | 993036 | 14               | L    | 22    | 993216 |

**Drop-In Hub**  
 Use XHS II® Hub Kit  
**203**  
 Refer to Pages 55-57 for Details on Hub Kit Components.

**MATCH**  
MICHIGAN

**BALLISTIC**  
MICHIGAN

| Boat Description/Length | ALUMINUM PROPELLERS |      |       |       |                 |        |
|-------------------------|---------------------|------|-------|-------|-----------------|--------|
|                         | Dia.                | Rot. | Pitch | Bld # | OEM Part #      | Part # |
| 21'-26' (18-31 MPH)     | 15-1/4              | R    | 15    | 3     | 6G5-45941-00-98 | 101025 |
| 19'-23' (27-37 MPH)     | 14-1/2              | R    | 17    | 3     | 6G5-45947-01-98 | 101027 |
| 19'-23' (27-37 MPH)     |                     |      |       |       |                 |        |
| 17'-21' (33-42 MPH)     | 14                  | R    | 19    | 3     | 6G5-45945-01-98 | 101028 |
| 17'-21' (33-42 MPH)     |                     |      |       |       |                 |        |
| 18'-19' (37-46 MPH)     | 13-3/4              | R    | 21    | 3     | 6G5-45943-01-98 | 101029 |
| 18'-19' (37-46 MPH)     |                     |      |       |       |                 |        |
| 17'-19' (39-48 MPH)     |                     |      |       |       |                 |        |
| 17'-19' (39-48 MPH)     |                     |      |       |       |                 |        |

**Rubber Hub Bushing**  
 Part # 65-441

| STAINLESS STEEL - A SERIES PROPELLERS |      |       |       |            |        |
|---------------------------------------|------|-------|-------|------------|--------|
| Dia.                                  | Rot. | Pitch | Bld # | OEM Part # | Part # |
| 14-7/8                                | R    | 15    | 3     |            | 933515 |
| 14-3/4                                | R    | 17    | 3     |            | 933517 |
| 14-3/4                                | L    | 17    | 3     |            | 937517 |
| 14-1/2                                | R    | 19    | 3     |            | 933519 |
| 14-1/2                                | L    | 19    | 3     |            | 937519 |
| 14-3/8                                | R    | 21    | 3     |            | 933521 |
| 14-3/8                                | L    | 21    | 3     |            | 937521 |
| 14-1/4                                | R    | 23    | 3     |            | 933523 |
| 14-1/4                                | L    | 23    | 3     |            | 937523 |

**Drop-In Hub**  
 Use XHS II® Hub Kit  
**203**  
 Refer to Pages 55-57 for Details on Hub Kit Components.



MATCH MICHIGAN



VORTEX MICHIGAN



APOLLO MICHIGAN



BALLISTIC MICHIGAN































































Key to Abbreviations: LL = Light Loads; SB = Sailboat; AL = All Loads; SK = Skiboat; WB = Workboat; HB = Houseboat; CR = Cruisers; HL = Heavy Loads; WD = Weedless

# RUBBER HUB ATTACHMENT HARDWARE

| Part Number | Description           | Page Listing | Engine Applications      |
|-------------|-----------------------|--------------|--------------------------|
| 990577      | Forward Thrust Washer |              | HONDA 8-20 HP            |
| 990578      | Forward Thrust Washer |              | HONDA 25-30 HP           |
| 990579      | Forward Thrust Washer |              | HONDA 35-60 HP           |
| 990580      | Forward Thrust Washer |              | HONDA 75-130 HP          |
| 990581      | Forward Thrust Washer |              | HONDA 115-250 HP         |
| 990582      | Forward Thrust Washer |              | NISSAN/TOHATSU 9.9-20 HP |
| 990583      | Forward Thrust Washer |              | NISSAN/TOHATSU 25-30 HP  |
| 990584      | Forward Thrust Washer |              | NISSAN/TOHATSU 35-55 HP  |
| 990585      | Forward Thrust Washer |              | SUZUKI 9.9-20 HP         |
| 990586      | Forward Thrust Washer |              | SUZUKI 20-30 HP          |
| 990587      | Forward Thrust Washer |              | SUZUKI 40-65 HP          |
| 990588      | Forward Thrust Washer |              | SUZUKI V4 4-STROKE       |
| 990589      | Forward Thrust Washer |              | YAMAHA "J" 9.9-15 HP     |
| 990590      | Forward Thrust Washer |              | YAMAHA "F" 20-30 HP      |
| 990591      | Forward Thrust Washer |              | YAMAHA "G" 40-60 HP      |
| 990592      | Forward Thrust Washer |              | YAMAHA "K" 60-100 HP     |
| 990593      | Forward Thrust Washer |              | YAMAHA "M" 115-300 HP    |



# RUBBER HUB ATTACHMENT HARDWARE

| Part Number | Description      |                                      | Prop Nut   | Flat Washer   | Spacer Washer   | Cotter Pin  |
|-------------|------------------|--------------------------------------|--|---|---|---|
| 990754      | Aft Hardware Kit | HONDA 8-20 HP / YAMAHA "J" 9.9-15 HP |    |    | -   |    |
| 990755      | Aft Hardware Kit | HONDA 25-30 HP                       |    |    | -   |    |
| 990756      | Aft Hardware Kit | HONDA 35-60 HP                       |    |    |    |    |
| 990757      | Aft Hardware Kit | HONDA 75-130 HP                      |    |    | -   |    |
| 990758      | Aft Hardware Kit | HONDA 115-250 HP                     |    |    |    |    |
| 990759      | Aft Hardware Kit | NISSAN/TOHATSU 9.9-20 HP             |    |    | -   |    |
| 990760      | Aft Hardware Kit | NISSAN/TOHATSU 25-30 HP              |    |    | -   |    |
| 990761      | Aft Hardware Kit | NISSAN/TOHATSU 35-55 HP              |   |   |   |   |
| 990762      | Aft Hardware Kit | SUZUKI 9.9-15 HP                     |  |  |  |  |
| 990763      | Aft Hardware Kit | SUZUKI DF 15A/20A HP                 |  |  | -   |  |
| 990764      | Aft Hardware Kit | SUZUKI 20-30 HP                      |  |  |  |  |
| 990765      | Aft Hardware Kit | SUZUKI 40-65 HP                      |  |  |  |  |
| 990766      | Aft Hardware Kit | SUZUKI V4 4-STROKE                   |  |  |  |  |
| 990767      | Aft Hardware Kit | YAMAHA "F" 20-30 HP                  |  |  |  |  |
| 990768      | Aft Hardware Kit | YAMAHA "G" 40-60 HP                  |  |  |  |  |
| 990769      | Aft Hardware Kit | YAMAHA "K" 60-100 HP                 |  |  |  |  |
| 990770      | Aft Hardware Kit | YAMAHA "M" 115-300 HP                |  |  |  |  |

# XHS® / XHS II® PROPELLER ACCESSORIES

|   |   |   |  |   |   |
|---|---|---|--|---|---|
| <br>9500-140 | <br>9660-1   | <br>9661-1   | <br>990312    | <br>990332   | <br>990340   |
| <br>990341   | <br>990344   | <br>990346   | <br>990347   | <br>990348   | <br>990404   |
| <br>990405   | <br>990406   | <br>990407   | <br>991202    | <br>991203   | <br>991204   |
| <br>991205   | <br>991206   | <br>991207   | <br>991208   | <br>991209   | <br>991210   |
| <br>991211  | <br>991212  | <br>991213  | <br>991214  | <br>991215  | <br>991216  |
| <br>991225 | <br>991226 | <br>991227 | <br>991228 | <br>991229 | <br>991230 |
| <br>991232 | <br>991233 | <br>991234 | <br>991235  | <br>991236 | <br>991237 |
| <br>991238 | <br>991239 | <br>991240 | <br>991241  | <br>991242 | <br>991243 |
| <br>991244 | <br>991247 | <br>991253 | <br>991273  | <br>991301 | <br>991312 |
| <br>991316 | <br>991372 |   |  |   |   |

# XHS® / XHS II® PROPELLER ACCESSORIES

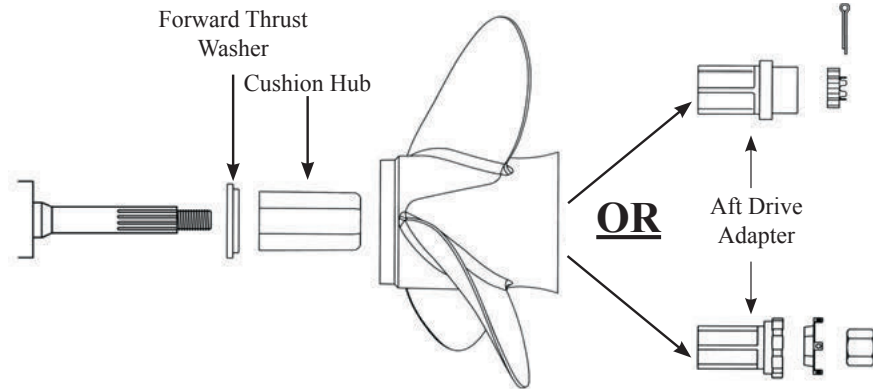

| Hub Kit | Description   | Part Number / Description                 |
|---------|---|---|
| 200     | Evinrude / Johnson 15 spline, 4-3/4" Gearcase 1991 to Present | 991202 Forward Thrust Washer              |
|         |   | 991203 Aft Drive Adapter                  |
|         |   | 991301 Cushion Hub                        |
| 201     | Evinrude / Johnson 15 spline, 4-3/4" Gearcase 1984 - 1990     | 991204 Forward Thrust Washer              |
|         |   | 991203 Aft Drive Adapter                  |
|         |   | 991301 Cushion Hub                        |
| 202     | Mercury/Force/Honda 15 spline, 4-3/4" Gearcase                | 991204 Forward Thrust Washer              |
|         |   | 990344 Tab Washer                         |
|         |   | 991205 Aft Drive Adapter                  |
|         |   | 990346 Propeller Nut                      |
|         |   | 991301 Cushion Hub                        |
| 203     | Yamaha V6 15 spline, 4-1/4" Gearcase                          | 991213 Forward Thrust Washer              |
|         |   | 991206 Aft Drive Adapter                  |
|         |   | 991301 Cushion Hub                        |
| 204     | Suzuki 15 spline, 4-1/4" Gearcase                             | 991207 Forward Thrust Washer              |
|         |   | 991208 Aft Drive Adapter                  |
|         |   | 991301 Cushion Hub                        |
| 205     | Volvo SX 19 spline, 4-3/4" Gearcase                           | 991202 Forward Thrust Washer              |
|         |   | 991209 Aft Drive Adapter                  |
|         |   | 991301 Cushion Hub                        |
| 206     | Evinrude/Johnson 13 spline, 4-1/4" Gearcase                   | 991210 Forward Thrust Washer              |
|         |   | 991211 Aft Drive Adapter                  |
|         |   | 991301 Cushion Hub                        |
| 207     | Honda 15 spline, 4-3/4" Gearcase                              | 991207 Forward Thrust Washer              |
|         |   | 991205 Aft Drive Adapter                  |
|         |   | 991301 Cushion Hub                        |
| 208     | Yamaha V4 15 spline, 4-1/4" Gearcase                          | 991212 Forward Thrust Washer              |
|         |   | 991206 Aft Drive Adapter                  |
|         |   | 990338 (1) - Washer SS 30 x 17 x 2.5 mm   |
|         |   | 991301 Cushion Hub                        |
| 209     | Nissan/Tohatsu 15 spline, 4-1/4" Gearcase                     | 991213 Forward Thrust Washer              |
|         |   | 991214 Aft Drive Adapter                  |
|         |   | 991301 Cushion Hub                        |
| 210     | Suzuki 13 spline, 4-1/4" Gearcase                             | 991215 Forward Thrust Washer              |
|         |   | 991211 Aft Drive Adapter                  |
|         |   | 991301 Cushion Hub                        |
| 225     | Suzuki/Johnson 15 spline, 4-1/4" Gearcase                     | 991253 Forward Thrust Washer              |
|         |   | 991205 Aft Drive Adapter                  |
|         |   | 990337 (1) - Washer SS 32 x 19.2 x 2.5 mm |
|         |   | 991301 Cushion Hub                        |
| 226     | Suzuki/Johnson DF140hp 4 stroke 15 spline 4-1/4" Gearcase     | 991204 Forward Thrust Washer              |
|         |   | 991205 Aft Drive Adapter                  |
|         |   | 990337 (1) - Washer SS 32 x 19.2 x 2.5 mm |
|         |   | 991301 Cushion Hub                        |
| 227     | Suzuki/Johnson DF70A/DF80A/DF90A 15 spline 4-1/4" Gearcase    | 991312 Forward Thrust Washer              |
|         |   | 991206 Aft Drive Adapter                  |
|         |   | 990337 (1) - Washer SS 32 x 19.2 x 2.5 mm |
|         |   | 991301 Cushion Hub                        |
| 228     | Evinrude ETEC G2 15 spline G2 Gearcase                        | 991402 G2 Forward Thrust Washer           |
|         |   | 991403 G2 Aft Drive Adapter               |
|         |   | 991401 G2 Cushion Hub                     |

# XHS® / XHS II® PROPELLER ACCESSORIES

| Hub Kit   | Description   | Part Number / Description                  |
|-----------|---|--|
| 111 / 211 | Evinrude / Johnson 13 spline, 3-3/8" Gearcase   | 991247 Forward Thrust Washer               |
|           |   | 991232 Aft Drive Adapter                   |
|           |   | 991225 Urethane Cushion Hub (111 Only)     |
|           |   | 991501 Delrin Cushion Hub (211 Only)       |
| 112 / 212 | Nissan / Tohatsu 13 spline, 3-1/4" Gearcase   | 991273 Forward Thrust Washer               |
|           |   | 991232 Aft Drive Adapter                   |
|           |   | 991225 Urethane Cushion Hub (112 Only)     |
|           |   | 991501 Delrin Cushion Hub (212 Only)       |
| 113 / 213 | Honda, Nissan/Tohatsu 13 spline, 3-1/4" Gearcase  | 991234 Forward Thrust Washer               |
|           |   | 991227 Aft Drive Adapter                   |
|           |   | 991225 Urethane Cushion Hub (113 Only)     |
|           |   | 991501 Delrin Cushion Hub (213 Only)       |
| 114 / 214 | Mercury / Mariner / Force 13 spline, 3-1/4" Gearcase  | 991236 Forward Thrust Washer               |
|           |   | 991227 Aft Drive Adapter                   |
|           |   | 991225 Urethane Cushion Hub (114 Only)     |
|           |   | 991501 Delrin Cushion Hub (214 Only)       |
| 115 / 215 | Evinrude/Johnson, Suzuki 13 spline, 3-1/4" Gearcase   | 991239 Forward Thrust Washer               |
|           |   | 991232 Aft Drive Adapter                   |
|           |   | 990337 (2) - Washer SS 32 x 19.2 x 2.5 mm  |
|           |   | 991225 Urethane Cushion Hub (115 Only)     |
|           |   | 991501 Delrin Cushion Hub (215 Only)       |
| 116 / 216 | Nissan / Tohatsu 13 spline, 3-1/4" Gearcase   | 991241 Forward Thrust Washer               |
|           |   | 991227 Aft Drive Adapter                   |
|           |   | 990338 (2) - Washer SS 17 x 30 x 2.5 mm    |
|           |   | 991225 Urethane Cushion Hub (116 Only)     |
|           |   | 991501 Delrin Cushion Hub (216 Only)       |
| 117 / 217 | Yamaha Outboards 13 spline, 3-1/2" Gearcase   | 991243 Forward Thrust Washer               |
|           |   | 991227 Aft Drive Adapter                   |
|           |   | 990338 (1) - Washer SS 17 x 30 x 2.5 mm    |
|           |   | 991225 Urethane Cushion Hub (117 Only)     |
|           |   | 991501 Delrin Cushion Hub (217 Only)       |
| 118 / 218 | Evinrude / Johnson Outboards 14 spline, 3" Gearcase   | 991237 Forward Thrust Washer               |
|           |   | 991229 Aft Drive Adapter                   |
|           |   | 991225 Urethane Cushion Hub (118 Only)     |
|           |   | 991501 Delrin Cushion Hub (218 Only)       |
| 119 / 219 | Honda Outboards 10 spline, 3" Gearcase  | 991233 Forward Thrust Washer               |
|           |   | 991226 Aft Drive Adapter                   |
|           |   | 991225 Urethane Cushion Hub (119 Only)     |
|           |   | 991501 Delrin Cushion Hub (219 Only)       |
| 120 / 220 | Mercury / Mariner / Force 10 spline, 3" Gearcase  | 991235 Forward Thrust Washer               |
|           |   | 991228 Aft Drive Adapter                   |
|           |   | 991225 Urethane Cushion Hub (120 Only)     |
|           |   | 991501 Delrin Cushion Hub (220 Only)       |
| 121 / 221 | Evinrude/Johnson & Suzuki 10 spline, 3" Gearcase  | 991238 Forward Thrust Washer               |
|           |   | 991230 Aft Drive Adapter                   |
|           |   | 990338 (1) - Washer SS 17 x 30 x 2.5 mm    |
|           |   | 991225 Urethane Cushion Hub (121 Only)     |
|           |   | 991501 Delrin Cushion Hub (221 Only)       |
| 122 / 222 | Nissan / Tohatsu 10 spline 3"<br>Mercury / Mariner / Sea Ray Outboards 10 spline, 3" Gearcase | 991240 Forward Thrust Washer               |
|           |   | 991226 Aft Drive Adapter                   |
|           |   | 991225 Urethane Cushion Hub (122 Only)     |
|           |   | 991501 Delrin Cushion Hub (222 Only)       |
| 123 / 223 | Yamaha Outboards 10 spline, 3" Gearcase   | 991242 Forward Thrust Washer               |
|           |   | 991230 Aft Drive Adapter                   |
|           |   | 990338 (1) - Washer SS 17 x 30 x 2.5 mm    |
|           |   | 991225 Urethane Cushion Hub (123 Only)     |
|           |   | 991501 Delrin Cushion Hub (223 Only)       |
|           | XHS II Standard Cushion Hub   | 991301 Delrin Cushion Hub                  |
|           | XHS II High Horsepower Inner Hub (Mercury® Part #850821A2)                                    | 991372 Solid Hub                           |
|           | V4 Gearcase Adapter Ring (3-Blade Propellers Only)  | 991216 V4 Adapter Ring (3-Blade)           |
|           | V4 Gearcase Adapter Ring (4-Blade Propellers Only)  | 991316 V4 Adapter Ring (4-Blade)           |
|           | 20-30 Horsepower Gearcase Adapter Ring  | 991244 Package Includes All Three Sizes    |
|           | XHS 9.9 HP - 70 HP Standard Cushion Hub   | 991225 Urethane Cushion Hub (111-123 Only) |
|           | NEW - XHS 9.9 HP - 70 HP Delrin Cushion Hub   | 991501 Delrin Cushion Hub (211-223 Only)   |

# PROPELLER CROSS REFERENCE

---

---

**MWM ALPHA-NUMERIC CROSS REFERENCE  
(PAGE B2-B4)**

**MWM - TURNING POINT® CROSS REFERENCE  
(PAGE B4)**

**MWM - SOLAS® CROSS REFERENCE  
(PAGE B5)**

**MWM - QUICKSILVER® CROSS REFERENCE  
(PAGE B6)**

**XHS® / XHS II® HUB SYSTEM CROSS REFERENCE  
(PAGE B6-B7)**

**OEM CROSS REFERENCE  
(PAGES B8-B31)**

*Propeller dimensions and performance may vary from OEM propeller.  
Product names may belong to Original Equipment Manufacturer.*

Evinrude®, Johnson®, TBX® and Cobra® are registered trademarks of BRP US, Inc. Honda® is a registered trademark of American Honda Motor Co., Inc. Mercury®, Mariner®, Force®, MerCruiser®, and Alpha One™ are registered trademarks of Brunswick Corporation. Nissan® is a registered trademark of Nissan Marine. Parsun® is a registered trademark of Parsun Power Machine (Suzhou) Co., Ltd. Selva® is a registered trademark of Selva Marine. Suzuki® is a registered trademark of American Suzuki Motor Corporation. Tohatsu® is a registered trademark of Tohatsu Corp. Volvo® is a registered trademark of AB Volvo Penta. Yamaha® is a registered trademark of Yamaha Motor Corporation, U.S.A. Solas® is a registered trademark of Solas Science & Engineering Co., Ltd. Turning Point® is a registered trademark of Turning Point Propellers, Inc.

Additional product names may belong to Original Equipment Manufacturers (OEM). All references to OEM, after-market, their trade names or their part numbers are for replacement identification purposes only.



# MICHIGAN WHEEL ALPHA-NUMERIC CROSS REFERENCE

| Alpha<br>Numeric | Status/Year<br>Numeric<br>Discontinued | Alpha<br>Numeric | Status/Year<br>Numeric<br>Discontinued | Alpha<br>Numeric | Status/Year<br>Numeric<br>Discontinued |
|------------------|--|------------------|--|------------------|--|
| AJC-63           | 152001                                 | Dis. 1992        | PJ-10                                  | 012007           | Current                                |
| AJC-317          | 016002                                 | Current          | PJ-11                                  | 012008           | Current                                |
| AJC-318          | 012062                                 | Dis. 1990        | PJ-13                                  | 012009           | Dis. 1994                              |
| AJC-417          | 012063                                 | Dis. 1996        | PJ-15                                  | 012010           | Dis. 2007                              |
| AJC-418          | 012064                                 | Dis. 1992        | PJ-16                                  | 012011           | Current                                |
| AJC-469          | 012065                                 | Dis. 1992        | PJ-18                                  | 012013           | Current                                |
| AM-416           | 012066                                 | Dis. 1991        | PJ-19                                  | 012109           | Current                                |
| AM-431           | 012067                                 | Dis. 2007        | PJ-21                                  | 012014           | Dis. 2010                              |
| AMC-128-C        | 071010                                 | Dis. 1995        | PJ-22                                  | 012015           | Current                                |
| AMC-152-C        | 071021                                 | Dis. 1995        | PJ-24                                  | 012016           | Current                                |
| AMC-308          | 072014                                 | Current          | PJ-27                                  | 012019           | Dis. 1996                              |
| AMC-310          | 072131                                 | Current          | PJ-28                                  | 012020           | Dis. 1990                              |
| AMC-314          | 072133                                 | Current          | PJ-29                                  | 012021           | Current                                |
| AMC-316          | 072134                                 | Dis. 2006        | PJ-30                                  | 012022           | Dis. 2008                              |
| AMC-394          | 072132                                 | Current          | PJ-31                                  | 012023           | Current                                |
| AMC-422          | 012068                                 | Dis. 2008        | PJ-32                                  | 012024           | Current                                |
| AMC-444          | 012070                                 | Dis. 1991        | PJ-33                                  | 012025           | Dis. 2011                              |
| AMC-445          | 012071                                 | Dis. 1992        | PJ-40                                  | 012026           | Dis. 2006                              |
| AMC-448          | 012072                                 | Dis. 1996        | PJ-41                                  | 012027           | Dis. 2008                              |
| AMC-490          | 152002                                 | Dis. 2003        | PJ-42                                  | 012028           | Dis. 2007                              |
| AMC-503          | 032073                                 | Dis. 1991        | PJ-44                                  | 012029           | Dis. 1993                              |
| AMC-506          | 032074                                 | Dis. 1991        | PJ-45                                  | 012030           | Current                                |
| AMC-535          | 152003                                 | Dis. 1996        | PJ-47                                  | 012031           | Dis. 2006                              |
| AMC-577-S        | 032075                                 | Dis. 1991        | PJ-49                                  | 012032           | Current                                |
| AMC-580-S        | 032077                                 | Dis. 2006        | PJ-50                                  | 012033           | Dis. 2003                              |
| C-15             | 152011                                 | Dis. 1993        | PJ-51                                  | 012034           | Dis. 1991                              |
| C-18             | 152012                                 | Dis. 1991        | PJ-53                                  | 012035           | Dis. 1992                              |
| DQ-320           | 012074                                 | Dis. 2006        | PJ-58                                  | 012036           | Current                                |
| DQ-328           | 012075                                 | Dis. 2007        | PJ-58-C                                | 011018           | Dis. 1990                              |
| DQ-430           | 032078                                 | Dis. 1991        | PJ-59                                  | 012037           | Current                                |
| E-40             | 152013                                 | Dis. 1990        | PJ-59-C                                | 011019           | Dis. 1990                              |
| EWC-19           | 012076                                 | Dis. 2006        | PJ-60                                  | 012038           | Dis. 2007                              |
| EWC-28           | 012077                                 | Dis. 1987        | PJ-60-C                                | 011020           | Dis. 1990                              |
| EWC-29           | 012078                                 | Dis. 1988        | PJ-61                                  | 012039           | Limited Inv.                           |
| G-20             | 072017                                 | Dis. 2010        | PJ-62                                  | 012040           | Dis. 2008                              |
| G-30             | 152014                                 | Dis. 2005        | PJ-73                                  | 012041           | Dis. 1996                              |
| G-40             | 152015                                 | Dis. 1996        | PJ-74                                  | 012042           | Dis. 2005                              |
| G-45             | 152016                                 | Dis. 1992        | PJ-75                                  | 012043           | Dis. 2005                              |
| G-50             | 152017                                 | Dis. 1996        | PJ-76                                  | 012044           | Dis. 2008                              |
| GC-54            | 072018                                 | Dis. 1996        | PJ-77                                  | 012045           | Dis. 2008                              |
| GC-55            | 072019                                 | Dis. 1996        | PJ-78                                  | 012046           | Dis. 1994                              |
| K-40             | 032079                                 | Dis. 1992        | PJ-79                                  | 012048           | Dis. 2000                              |
| K-50             | 032080                                 | Dis. 1992        | PJ-80                                  | 012049           | Dis. 1996                              |
| K-70             | 032081                                 | Dis. 1992        | PJ-81                                  | 012050           | Dis. 1996                              |
| K-74             | 032082                                 | Dis. 1992        | PJ-82                                  | 012051           | Dis. 1996                              |
| PC-4             | 072020                                 | Dis. 1991        | PJ-83-C                                | 011105           | Current                                |
| PC-5             | 072120                                 | Dis. 1992        | PJ-87                                  | 012047           | Current                                |
| PC-6             | 072021                                 | Dis. 1996        | PJ-88-C                                | 011001           | Current                                |
| PC-9             | 072022                                 | Dis. 1996        | PJ-89-C                                | 011002           | Current                                |
| PC-10            | 072023                                 | Dis. 1996        | PJ-90-C                                | 011003           | Current                                |
| PC-12            | 072024                                 | Dis. 2006        | PJ-91-C                                | 011004           | Current                                |
| PC-20            | 072026                                 | Dis. 2006        | PJ-94                                  | 012053           | Dis. 2006                              |
| PC-24            | 072121                                 | Dis. 2006        | PJ-95                                  | 012054           | Current                                |
| PC-26            | 072125                                 | Dis. 1996        | PJ-96                                  | 012055           | Current                                |
| PC-28            | 072122                                 | Dis. 2006        | PJ-97                                  | 012056           | Current                                |
| PC-32            | 072121                                 | Dis. 2006        | PJ-98                                  | 012057           | Current                                |
| PC-90            | 072126                                 | Dis. 1994        | PJ-199-C                               | 011015           | Dis. 2008                              |
| PC-112           | 072123                                 | Current          | PJ-200                                 | 012059           | Dis. 1996                              |
| PJ-3             | 012001                                 | Dis. 2007        | PJ-200-C                               | 011016           | Current                                |
| PJ-5             | 012002                                 | Dis. 1996        | PJ-201-C                               | 011006           | Current                                |
| PJ-6             | 012003                                 | Dis. 1996        | PJ-202-C                               | 011007           | Current                                |
| PJ-7             | 012004                                 | Dis. 2006        | PJ-203-C                               | 011008           | Current                                |
| PJ-8             | 012005                                 | Current          | PJ-204-C                               | 011009           | Current                                |
| PJ-9             | 012006                                 | Dis. 2008        | PJ-205-C                               | 011010           | Dis. 2010                              |
| PJ-300           | 012060                                 | Dis. 2009        | PM-4                                   | 032012           | Dis. 1992                              |
| PM-4             | 032012                                 | Dis. 1992        | PM-6                                   | 032013           | Dis. 1996                              |
| PM-6             | 032013                                 | Dis. 1996        | PM-8                                   | 032014           | Dis. 2003                              |
| PM-8             | 032014                                 | Dis. 2003        | PM-10                                  | 032015           | Dis. 1994                              |
| PM-10            | 032015                                 | Dis. 1994        | PM-11                                  | 032016           | Dis. 1994                              |
| PM-11            | 032016                                 | Dis. 1994        | PM-16                                  | 032017           | Dis. 1992                              |
| PM-16            | 032017                                 | Dis. 1992        | PM-18                                  | 032018           | Dis. 1992                              |
| PM-18            | 032018                                 | Dis. 1992        | PM-19                                  | 032019           | Dis. 2008                              |
| PM-19            | 032019                                 | Dis. 2008        | PM-20                                  | 032020           | Current                                |
| PM-20            | 032020                                 | Current          | PM-21                                  | 032021           | Current                                |
| PM-21            | 032021                                 | Current          | PM-22-C                                | 031047           | Dis. 2008                              |
| PM-22-C          | 031047                                 | Dis. 2008        | PM-23-C                                | 031048           | Current                                |
| PM-23-C          | 031048                                 | Current          | PM-24-C                                | 031049           | Current                                |
| PM-24-C          | 031049                                 | Current          | PM-26                                  | 032111           | Dis. 1993                              |
| PM-26            | 032111                                 | Dis. 1993        | PM-27                                  | 032025           | Dis. 1996                              |
| PM-27            | 032025                                 | Dis. 1996        | PM-28                                  | 032027           | Dis. 1992                              |
| PM-28            | 032027                                 | Dis. 1992        | PM-29                                  | 032028           | Dis. 1992                              |
| PM-29            | 032028                                 | Dis. 1992        | PM-30                                  | 032112           | Dis. 1993                              |
| PM-30            | 032112                                 | Dis. 1993        | PM-39                                  | 032030           | Dis. 1987                              |
| PM-39            | 032030                                 | Dis. 1987        | PM-40                                  | 032031           | Dis. 1987                              |
| PM-40            | 032031                                 | Dis. 1987        | PM-42                                  | 032032           | Dis. 1987                              |
| PM-42            | 032032                                 | Dis. 1987        | PM-54                                  | 032033           | Dis. 1991                              |
| PM-54            | 032033                                 | Dis. 1991        | PM-55                                  | 032034           | Dis. 1994                              |
| PM-55            | 032034                                 | Dis. 1994        | PM-56                                  | 032035           | Dis. 1993                              |
| PM-56            | 032035                                 | Dis. 1993        | PM-60                                  | 032036           | Dis. 1987                              |
| PM-60            | 032036                                 | Dis. 1987        | PM-61                                  | 032037           | Dis. 1987                              |
| PM-61            | 032037                                 | Dis. 1987        | PM-62                                  | 032038           | Dis. 1987                              |
| PM-62            | 032038                                 | Dis. 1987        | PM-211-C                               | 031021           | Dis. 2008                              |
| PM-211-C         | 031021                                 | Dis. 2008        | PM-213-C                               | 031022           | Current                                |
| PM-213-C         | 031022                                 | Current          | PM-215-C                               | 031023           | Current                                |
| PM-215-C         | 031023                                 | Current          | PM-217-C                               | 031024           | Current                                |
| PM-217-C         | 031024                                 | Current          | PM-219-C                               | 031025           | Current                                |
| PM-219-C         | 031025                                 | Current          | PM-221-C                               | 031026           | Current                                |
| PM-221-C         | 031026                                 | Current          | PM-223-C                               | 031027           | Dis. 2006                              |
| PM-223-C         | 031027                                 | Dis. 2006        | PM-315-C                               | 031041           | Current                                |
| PM-315-C         | 031041                                 | Current          | PM-317-C                               | 031042           | Current                                |
| PM-317-C         | 031042                                 | Current          | PM-319-C                               | 031043           | Current                                |
| PM-319-C         | 031043                                 | Current          | PM-321-C                               | 031044           | Current                                |
| PM-321-C         | 031044                                 | Current          | PM-323-C                               | 031045           | Current                                |
| PM-323-C         | 031045                                 | Current          | PM-513                                 | 032039           | Dis. 2008                              |
| PM-513           | 032039                                 | Dis. 2008        | PM-515                                 | 032040           | Current                                |
| PM-515           | 032040                                 | Current          | PM-518                                 | 032041           | Current                                |
| PM-518           | 032041                                 | Current          | PM-521                                 | 032042           | Current                                |
| PM-521           | 032042                                 | Current          | PM-524                                 | 032043           | Current                                |
| PM-524           | 032043                                 | Current          | PM-527                                 | 032044           | Current                                |
| PM-527           | 032044                                 | Current          | PM-530                                 | 032045           | Current                                |
| PM-530           | 032045                                 | Current          | PM-600-C                               | 031015           | Current                                |
| PM-600-C         | 031015                                 | Current          | PM-612-C                               | 031016           | Current                                |
| PM-612-C         | 031016                                 | Current          | PM-613-C                               | 031017           | Current                                |
| PM-613-C         | 031017                                 | Current          | PM-614-C                               | 031018           | Current                                |
| PM-614-C         | 031018                                 | Current          | PM-615-C                               | 031019           | Current                                |
| PM-615-C         | 031019                                 | Current          | PM-617-C                               | 031020           | Current                                |
| PM-617-C         | 031020                                 | Current          | PR-4                                   | 072027           | Dis. 1991                              |
| PR-4             | 072027                                 | Dis. 1991        | PR-8                                   | 072028           | Dis. 1996                              |
| PR-8             | 072028                                 | Dis. 1996        | PR-10                                  | 072029           | Dis. 1991                              |
| PR-10            | 072029                                 | Dis. 1991        | PR-20                                  | 012079           | Dis. 1993                              |
| PR-20            | 012079                                 | Dis. 1993        | PR-22                                  | 012080           | Dis. 1993                              |
| PR-22            | 012080                                 | Dis. 1993        | PR-24                                  | 012081           | Dis. 1992                              |
| PR-24            | 012081                                 | Dis. 1992        | PR-26                                  | 012082           | Dis. 1992                              |
| PR-26            | 012082                                 | Dis. 1992        | PR-31                                  | 032083           | Dis. 1996                              |
| PR-31            | 032083                                 | Dis. 1996        | PR-33                                  | 032084           | Dis. 2007                              |
| PR-33            | 032084                                 | Dis. 2007        | PR-35                                  | 032085           | Dis. 2007                              |
| PR-35            | 032085                                 | Dis. 2007        | PR-37                                  | 032086           | Dis. 2006                              |
| PR-37            | 032086                                 | Dis. 2006        |  |                  |  |

# MICHIGAN WHEEL ALPHA-NUMERIC CROSS REFERENCE

| Alpha          |                |                     | Alpha          |                |                     | Alpha          |                |                     |
|----------------|----------------|---------------------|----------------|----------------|---------------------|----------------|----------------|---------------------|
| <u>Numeric</u> | <u>Numeric</u> | <u>Status/Year</u>  | <u>Numeric</u> | <u>Numeric</u> | <u>Status/Year</u>  | <u>Numeric</u> | <u>Numeric</u> | <u>Status/Year</u>  |
|                |                | <u>Discontinued</u> |                |                | <u>Discontinued</u> |                |                | <u>Discontinued</u> |
| PR-39          | 032087         | Dis. 2007           | PR-409         | 072063         | Dis. 1987           | SMC-339        | 082026         | Dis. 1997           |
| PR-43          | 032088         | Dis. 1994           | PR-412         | 072064         | Dis. 1987           | SMC-340        | 082059         | Dis. 1997           |
| PR-74          | 072030         | Dis. 1991           | PR-413         | 072065         | Dis. 1987           | SMC-341        | 082060         | Dis. 1997           |
| PR-76          | 072031         | Dis. 1992           | PR-416         | 072066         | Dis. 1987           | SMC-342        | 082027         | Dis. 1997           |
| PR-78          | 072032         | Dis. 2007           | PR-417         | 072067         | Dis. 1987           | SMC-343        | 082028         | Dis. 1997           |
| PR-80          | 072033         | Dis. 2006           | PR-420         | 012095         | Dis. 1993           | SMC-344        | 082029         | Dis. 1997           |
| PR-82          | 072034         | Dis. 2005           | PR-421         | 016006         | Dis. 1992           | SMC-345        | 082030         | Dis. 1997           |
| PR-90          | 012083         | Dis. 1992           | PR-422         | 012096         | Dis. 1992           | SMC-346        | 082031         | Dis. 1997           |
| PR-92          | 012084         | Dis. 1993           | PR-423         | 016007         | Dis. 1991           | SMC-350        | 082053         | Dis. 1996           |
| PR-94          | 012085         | Dis. 1992           | PR-424         | 012097         | Dis. 1994           | SMC-351        | 082036         | Dis. 1995           |
| PR-95          | 016004         | Dis. 1991           | PR-425         | 016008         | Dis. 1992           | SMC-374-C      | 031035         | Dis. 2003           |
| PR-96          | 012086         | Dis. 1993           | PR-426         | 012098         | Dis. 1992           | SMC-376-C      | 031036         | Dis. 2003           |
| PR-97          | 016005         | Dis. 1992           | PR-427         | 016009         | Dis. 1987           | SMC-378-C      | 031037         | Dis. 2005           |
| PR-105         | 012087         | Dis. 1993           | PR-432         | 072114         | Dis. 1993           | SMC-380-C      | 031038         | Dis. 2005           |
| PR-109         | 012088         | Dis. 1992           | PR-434         | 072068         | Dis. 1996           | SMC-382-C      | 031039         | Dis. 2005           |
| PR-115         | 012089         | Dis. 2008           | PR-552         | 072069         | Dis. 1992           | SMC-384-C      | 031040         | Dis. 1997           |
| PR-118         | 012090         | Dis. 2007           | PR-553         | 072070         | Dis. 1996           | SMC-434        | 036004         | Dis. 1992           |
| PR-120         | 012091         | Current             | PR-554         | 072071         | Dis. 1992           | SMC-435        | 036005         | Dis. 1992           |
| PR-122         | 012092         | Current             | PR-555         | 072072         | Dis. 1990           | SMC-436        | 036006         | Dis. 1992           |
| PR-124         | 012093         | Dis. 2007           | PR-884         | 072073         | Dis. 1991           | SMC-437        | 036007         | Dis. 1992           |
| PR-126         | 012094         | Dis. 2007           | PS-1           | 062001         | Dis. 1992           | SMC-438        | 036008         | Dis. 1991           |
| PR-130         | 072035         | Dis. 1991           | PS-2           | 062002         | Dis. 1992           | SMC-439        | 036009         | Dis. 1992           |
| PR-132         | 072036         | Dis. 1991           | PS-5           | 062003         | Dis. 1992           | SMC-440        | 036010         | Dis. 1987           |
| PR-134         | 072037         | Dis. 1991           | PS-6           | 062004         | Dis. 1993           | SMC-504-C      | 031034         | Dis. 2003           |
| PR-136         | 072038         | Dis. 1991           | PS-7           | 062005         | Dis. 1991           | SMC-530        | 072078         | Dis. 1987           |
| PR-138         | 072039         | Dis. 1991           | PS-25          | 152020         | Dis. 1992           | SMC-556        | 072077         | Dis. 1987           |
| PR-151         | 032089         | Dis. 2004           | PS-40          | 152021         | Dis. 1993           | SMC-566        | 072076         | Dis. 1987           |
| PR-153         | 032090         | Dis. 2004           | PS-71          | 152023         | Dis. 1992           | SMC-570        | 072079         | Dis. 1987           |
| PR-155         | 032091         | Dis. 2004           | PS-72          | 152024         | Dis. 1991           | SMC-582        | 072086         | Dis. 1987           |
| PR-155-C       | 031001         | Dis. 2003           | PS-73          | 152025         | Dis. 1992           | SMC-592        | 072083         | Dis. 1987           |
| PR-157         | 032092         | Dis. 2004           | PS-513         | 062006         | Dis. 1991           | SMC-604        | 072084         | Dis. 1987           |
| PR-157-C       | 031002         | Dis. 2003           | PS-515         | 062007         | Dis. 1991           | SMC-606        | 072085         | Dis. 1987           |
| PR-159         | 032093         | Dis. 2004           | PS-518         | 062008         | Dis. 1991           | SMC-635        | 152035         | Dis. 1991           |
| PR-159-C       | 031003         | Dis. 2003           | PS-521         | 062009         | Dis. 1991           | SMC-637        | 152036         | Dis. 1992           |
| PR-161         | 032094         | Dis. 2004           | PS-524         | 062010         | Dis. 1991           | SMC-713        | 152037         | Dis. 1992           |
| PR-161-C       | 031004         | Dis. 2003           | PS-527         | 062011         | Dis. 1991           | SMC-715        | 152038         | Dis. 1992           |
| PR-163         | 032095         | Dis. 2004           | PY-315-C       | 101001         | Dis. 1997           | SMC-720        | 072088         | Dis. 1993           |
| PR-163-C       | 031005         | Dis. 1994           | PY-317-C       | 101003         | Dis. 1997           | SMC-721        | 072090         | Dis. 1992           |
| PR-248         | 072047         | Dis. 1987           | PY-319-C       | 101005         | Dis. 1997           | SMC-733        | 072092         | Dis. 1990           |
| PR-250         | 072048         | Dis. 1987           | PY-321-C       | 101007         | Dis. 1997           | SMC-734        | 072093         | Dis. 1991           |
| PR-256         | 072049         | Dis. 1987           | PY-323-C       | 101009         | Dis. 1994           | SMC-735        | 072095         | Dis. 1990           |
| PR-258         | 072050         | Dis. 1987           | PY-415-C       | 101010         | Dis. 1997           | SMC-736        | 072089         | Dis. 1992           |
| PR-260         | 072051         | Dis. 1987           | PY-417-C       | 101011         | Dis. 1997           | SMC-737        | 072091         | Dis. 1992           |
| PR-264         | 072053         | Dis. 1987           | PY-419-C       | 101012         | Dis. 1997           | SMC-744        | 072097         | Dis. 1992           |
| PR-276         | 072054         | Dis. 2007           | PY-421-C       | 101013         | Dis. 1997           | SMC-750        | 072099         | Dis. 1992           |
| PR-278         | 072055         | Current             | PY-423-C       | 101014         | Dis. 1994           | SMC-751        | 072098         | Dis. 1996           |
| PR-333         | 032096         | Dis. 1993           | SA-10          | 152030         | Dis. 1994           | SMC-760        | 072096         | Dis. 1996           |
| PR-335         | 032097         | Dis. 1996           | SAC-371        | 152034         | Dis. 1992           | SMC-765        | 072101         | Dis. 1994           |
| PR-335-C       | 031007         | Dis. 1990           | SMC-7          | 152029         | Dis. 1987           | SMC-768        | 072103         | Dis. 1991           |
| PR-337         | 032098         | Dis. 1995           | SMC-12         | 012100         | Dis. 1996           | SMC-769        | 072104         | Dis. 1996           |
| PR-337-C       | 142002         | Dis. 2009           | SMC-18         | 012101         | Dis. 2007           | SMC-773        | 072105         | Dis. 1990           |
| PR-339         | 032099         | Dis. 2007           | SMC-34         | 016011         | Dis. 1992           | SMC-774        | 072106         | Dis. 1996           |
| PR-339-C       | 031009         | Dis. 1990           | SMC-38         | 016013         | Dis. 1992           | SMC-800        | 032104         | Dis. 1987           |
| PR-343         | 032100         | Dis. 1996           | SMC-39         | 012102         | Current             | SMC-801        | 032103         | Dis. 1987           |
| PR-343-C       | 031010         | Dis. 1990           | SMC-46         | 072074         | Dis. 1994           | SMC-802        | 032106         | Dis. 1996           |
| PR-345         | 032101         | Dis. 1993           | SMC-47         | 012063         | Dis. 1996           | SMC-803        | 032105         | Dis. 1992           |
| PR-345-C       | 031011         | Dis. 1990           | SMC-292        | 082022         | Dis. 2007           | SMC-804        | 032108         | Dis. 1992           |
| PR-396         | 072056         | Dis. 1987           | SMC-293        | 082021         | Dis. 2011           | SMC-805        | 032107         | Dis. 1992           |
| PR-397         | 072057         | Dis. 1987           | SMC-294        | 082024         | Dis. 1996           | SMC-806        | 032110         | Dis. 1990           |
| PR-400         | 072058         | Dis. 1987           | SMC-295        | 082023         | Dis. 2007           | SMC-807        | 032109         | Dis. 1995           |
| PR-401         | 072059         | Dis. 1987           | SMC-304        | 012103         | Dis. 1992           | SMC-808        | 072112         | Dis. 1992           |
| PR-404         | 072060         | Dis. 1987           | SMC-308        | 012104         | Dis. 1992           | SMC-809        | 072113         | Dis. 1990           |
| PR-405         | 072061         | Dis. 1987           | SMC-312        | 012105         | Dis. 1992           | SMC-862        | 012106         | Dis. 1992           |
| PR-408         | 072062         | Dis. 1987           | SMC-335        | 082025         | Dis. 1997           | SMC-864        | 012107         | Dis. 1992           |

# MICHIGAN WHEEL ALPHA-NUMERIC CROSS REFERENCE

| Alpha<br>Numeric | Status/Year<br>Numeric<br>Discontinued | Alpha<br>Numeric | Status/Year<br>Numeric<br>Discontinued | Alpha<br>Numeric | Status/Year<br>Numeric<br>Discontinued |
|------------------|--|------------------|--|------------------|--|
| SMC-885          | 082035 Dis. 1992                       | SSM-272-C        | 033020 Dis. 1994                       | SSO-817-C        | 013015 Dis. 1995                       |
| SMC-898          | 082037 Dis. 1994                       | SSM-292-C        | 033021 Dis. 1995                       | SSO-819-C        | 013016 Dis. 1994                       |
| SMC-900          | 082041 Dis. 1992                       | SSM-312-C        | 033022 Dis. 1996                       | SSO-821-C        | 013017 Dis. 1996                       |
| SMC-906          | 082043 Dis. 1996                       | SSM-350-C        | 033007 Dis. 2005                       | SSO-922-C        | 013007 Dis. 1990                       |
| SMC-922          | 082047 Dis. 1992                       | SSM-354-C        | 033008 Dis. 2005                       | SSO-924-C        | 013008 Dis. 1990                       |
| SMC-925          | 082049 Dis. 1995                       | SSM-358-C        | 033009 Dis. 2005                       | SSO-926-C        | 013009 Dis. 1990                       |
| SMC-929          | 082051 Dis. 1991                       | SSM-615-II-C     | 033016 Dis. 2005                       | SSV-171-C        | 083001 Dis. 2006                       |
| SMC-940          | 082052 Dis. 1992                       | SSM-617-II-C     | 033017 Dis. 2006                       | SSV-172-C        | 083002 Dis. 2006                       |
| SMC-944          | 082054 Dis. 1992                       | SSM-619-II-C     | 033018 Dis. 2006                       | SSV-192-C        | 083004 Dis. 2006                       |
| SPC-180          | 072107 Current                         | SSM-621-II-C     | 033019 Dis. 2006                       | SSV-211-C        | 083005 Dis. 2006                       |
| SPC-182          | 072108 Current                         | SSM-822-C        | 033013 Dis. 1990                       | SSV-212-C        | 083006 Dis. 2006                       |
| SPC-184          | 072109 Dis. 2006                       | SSM-824-C        | 033014 Dis. 1990                       | SSY-615-II-C     | 103025 Dis. 2006                       |
| SSC-315-II-C     | 073002 Dis. 2005                       | SSM-826-C        | 033015 Dis. 1990                       | SSY-617-II-C     | 103026 Dis. 2006                       |
| SSC-317-II-C     | 073003 Dis. 2005                       | SSO-315-C        | 013010 Dis. 2007                       | SSY-619-II-C     | 103027 Dis. 2006                       |
| SSC-319-II-C     | 073004 Dis. 2005                       | SSO-515-II-C     | 013011 Dis. 1990                       | SSY-621-II-C     | 103028 Dis. 1997                       |
| SSC-321-II-C     | 073005 Dis. 1996                       | SSO-517-C        | 013012 Dis. 1990                       | SSY-715-C        | 103016 Dis. 1991                       |
| SSC-614-C        | 073006 Dis. 1996                       | SSO-519-C        | 013013 Dis. 1990                       | SSY-717-C        | 103018 Dis. 2006                       |
| SSM-212-C        | 033001 Dis. 2006                       | SSO-521-C        | 013014 Dis. 1990                       | SSY-719-C        | 103020 Dis. 2006                       |
| SSM-245-C        | 033002 Dis. 2006                       | SSO-645-C        | 013001 Dis. 1990                       | SSY-721-C        | 103022 Dis. 2007                       |
| SSM-247-C        | 033003 Dis. 2006                       | SSO-647-C        | 013002 Dis. 1990                       | SSY-722-C        | 103050 Dis. 2003                       |
| SSM-249-C        | 033004 Dis. 2006                       | SSO-649-C        | 013003 Dis. 1990                       | SSY-723-C        | 103024 Dis. 2003                       |
| SSM-251-C        | 033005 Dis. 2005                       | SSO-651-C        | 013004 Dis. 1990                       | SSY-724-C        | 103052 Dis. 2003                       |
| SSM-253-C        | 033006 Dis. 2006                       | SSO-653-C        | 013005 Dis. 1990                       | SSY-726-C        | 103054 Dis. 2003                       |

CAN'T FIND YOUR ALPHA-NUMERIC PART NUMBER LISTED ABOVE?  
FOR ADDITIONAL ASSISTANCE CONTACT MICHIGAN WHEEL MARINE CUSTOMER SERVICE AT 1-800-369-4335

## TURNING POINT® - MICHIGAN WHEEL CROSS REFERENCE

| Turning Point®<br>Part # | Alternate<br>TP Part # | MW<br>Part # | Turning Point®<br>Part # | Alternate<br>TP Part # | MW<br>Part # | Turning Point®<br>Part # | Alternate<br>TP Part # | MWM<br>Part # |
|--------------------------|------------------------|--------------|--------------------------|------------------------|--------------|--------------------------|------------------------|---------------|
| E-1415                   |                        | 993042       | H1-1319                  |                        | 992115       | LE2-1413                 | 2143 1311              | 992112        |
| E-1417                   |                        | 993043       | H1-1321                  |                        | 992116       | PA-1417                  | 3150 1710              | 993043        |
| E-1419                   |                        | 993044       | H1-1413                  |                        | 992112       | PA-1417-L                | 3150 1720              | 993053        |
| E-1421                   |                        | 993045       | H2-1117                  | 2131 1710              | 992303       | PA-1419                  | 3150 1910              | 993044        |
| E-1423                   |                        | 993046       | H2-1213                  | 2131 1310              | 992311       | PA-1419-L                | 3150 1920              | 993054        |
| E1-1012                  | 3130 1211              | 993405       | H2-1215                  | 2131 1510              | 992312       | PA-1421                  | 3150 2110              | 993045        |
| E1-1013                  | 3130 1311              | 993406       | H2-1315                  |                        | 992113       | PA-1421-L                | 3150 2120              | 993055        |
| E1-1014                  | 3130 1411              | 993407       | H2-1317                  |                        | 992114       | PA-1423                  | 3150 2310              | 993046        |
| E1-1015                  | 3130 1511              | 993408       | H2-1319                  |                        | 992115       | PA-1423-L                | 3150 2320              | 993056        |
| E1-1315                  |                        | 993143       | H2-1321                  |                        | 992116       | PA1-1315                 | 3140 1510              | 993143        |
| E1-1317                  |                        | 993144       | H2-1413                  |                        | 992112       | PA1-1317                 | 3140 1710              | 993144        |
| E1-1319                  |                        | 993145       | LE-1417                  | 2150 1711              | 992003       | PA1-1319                 | 3140 1910              | 993145        |
| E1-1321                  |                        | 993146       | LE-1419                  | 2150 1911              | 992004       | PA1-1321                 | 3140 2110              | 993146        |
| E2-1315                  |                        | 993143       | LE-1421                  | 2150 2111              | 992005       | PA2-1315                 | 3141 1510              | 993143        |
| E2-1317                  |                        | 993144       | LE-1423                  | 2150 2311              | 992006       | PA2-1317                 | 3141 1710              | 993144        |
| E2-1319                  |                        | 993145       | LE-1515                  | 2150 1511              | 992002       | PA2-1319                 | 3141 1910              | 993145        |
| E2-1321                  |                        | 993146       | LE1-1315                 | 2143 1511              | 992113       | PA2-1321                 | 3141 2110              | 993146        |
| H-1417                   |                        | 992003       | LE1-1317                 | 2143 1711              | 992114       | R1-1011                  | 2120 1110              | 992503        |
| H-1419                   |                        | 992004       | LE1-1317-4               | 2143 1730              | 941417       | R1-1013                  | 2120 1310              | 992505        |
| H-1421                   |                        | 992005       | LE1-1319-4               | 2143 1930              | 941419       | R2-1011                  | 2121 1110              | 992503        |
| H-1423                   |                        | 992006       | LE1-1319                 | 2143 1911              | 992115       | R2-1013                  | 2121 1310              | 992505        |
| H-1515                   |                        | 992002       | LE1-1321                 | 2143 2111              | 992116       | R3-1011                  | 2122 1110              | 992503        |
| H1-1011                  | 2130 1110              | 992404       | LE1-1413                 | 2143 1311              | 992112       | R3-1013                  | 2122 1310              | 992505        |
| H1-1012                  | 2130 1210              | 992405       | LE2-1315                 | 2143 1511              | 992113       | VO-1517                  | 3152 1710              | 993023        |
| H1-1013                  | 2130 1310              | 992406       | LE2-1317                 | 2143 1711              | 992114       | VO-1517-L                | 3152 1720              | 993033        |
| H1-1014                  | 2130 1410              | 992407       | LE2-1317-4               | 2143 1730              | 941417       | VO-1519                  | 3152 1910              | 993024        |
| H1-1015                  | 2130 1510              | 992408       | LE2-1319-4               | 2143 1930              | 941419       | VO-1519-L                | 3152 1920              | 993034        |
| H1-1210                  | 2130 1010              | 992602       | LE2-1319                 | 2143 1911              | 992115       | VO-1521                  | 3152 2110              | 993025        |
| H1-1315                  |                        | 992113       | LE2-1321                 | 2143 2111              | 992116       | VO-1521-L                | 3152 2120              | 993035        |
| H1-1317                  |                        | 992114       |                          |                        |              |                          |                        |               |

# SOLAS® - MICHIGAN WHEEL CROSS REFERENCE

| Solas®<br>Part #       | MWM<br>Part # | Solas®<br>Part #       | MWM<br>Part # | Solas®<br>Part #       | MWM<br>Part # | Solas®<br>Part # | MWM<br>Part # |
|------------------------|---------------|------------------------|---------------|------------------------|---------------|------------------|---------------|
| 1111-093-07            | 032056        | 2441-133-17            | 933417        | 3553-140-25            | 963525        | 9431-130-21      | 993146        |
| 1111-093-08            | 032053        | 2441-133-19            | 933419        | 4111-093-09            | 062103        | 9431-133-17      | 993144        |
| 1111-093-09            | 032052        | 2441-138-15            | 933415        | 4111-093-10            | 062104        | 9431-135-15      | 993143        |
| 1111-093-10            | 032050        | 2511-142-23            | 011010        | 4111-093-11            | 062105        | 9431-138-13      | 992112        |
| 1211-100-14            | 031047        | 2511-143-21            | 011009        | 4211-100-14            | 062209        | 9432-130-19      | 993155        |
| 1211-101-13            | 031048        | 2511-145-19            | 011008        | 4211-100-15            | 062210        | 9432-133-17      | 993154        |
| 1211-105-11            | 031049        | 2511-148-17            | 011007        | 4211-101-13            | 062207        | 9432-135-15      | 993153        |
| 1231-100-15            | 933015        | 2511-150-15            | 011006        | 4211-103-12            | 062206        | 9511-143-21      | 992005        |
| 1231-101-13            | 933013        | 2511-155-13            | 011016        | 4211-105-11            | 062205        | 9511-145-19      | 992004        |
| 1311-110-15            | 031019        | 2551-140-24            | 953524        | 4211-110-09            | 062208        | 9511-148-17      | 992003        |
| 1311-111-13            | 031047        | 2551-143-22            | 345051        | 4231-100-15            | 933015        | 9511-150-15      | 992002        |
| 1311-111-14            | 031018        | 2551-145-21            | 933521        | 4231-101-13            | 933013        | 9513-143-19      | 992204        |
| 1311-114-12            | 031017        | 2551-148-16            | 933515        | 4311-114-15            | 062215        | 9513-148-17      | 992203        |
| 1311-116-11            | 031016        | 2551-148-17            | 933517        | 4311-114-16            | 062216        | 9513-148-15      | 992202        |
| 1311-120-10            | 032142        | 2551-148-19            | 933519        | 4311-116-12            | 062212        | 9531-140-19      | 993044        |
| 1311-121-09            | 031015        | 2552-145-21            | 937521        | 4311-116-13            | 062213        | 9531-140-21      | 993045        |
| 1411-130-19            | 031043        | 2552-148-17            | 937517        | 4311-116-14            | 062214        | 9531-140-23      | 993046        |
| 1411-130-21            | 031044        | 2552-148-19            | 937519        | 4311-118-11            | 062211        | 9531-143-17      | 993043        |
| 1411-133-17            | 031042        | 2553-140-23            | 963523        | 4311-120-10            | 032045        | 9531-145-15      | 993042        |
| 1411-135-15            | 031041        | 2553-140-25            | 963525        | 4331-110-15            | 933215        | 9532-140-19      | 993054        |
| 1411-138-13            | 031202        | 3011-085-08            | 102002        | 4331-111-13            | 993213        | 9532-140-21      | 993055        |
| 1411-140-11            | 031254        | 3111-093-08            | 102003        | 4411-130-19            | 061103        | 9532-140-23      | 993056        |
| 1413-133-13            | 941413        | 3111-093-09            | 102004        | 4411-130-21            | 061104        | 9532-143-17      | 993053        |
| 1413-130-15            | 941415        | 3111-093-10            | 102005        | 4411-133-17            | 061102        | 9532-145-15      | 993052        |
| 1413-128-17            | 941417        | 3111-093-12            | 102107        | 4411-135-15            | 061101        | 9553-140-21      | 993205        |
| 1413-125-19            | 941419        | 3211-099-09            | 022001        | 4411-138-13            | 061105        | 9553-140-23      | 993206        |
| 1431-130-19            | 933419        | 3211-099-10            | 022002        | 4411-140-11            | 061107        | 9553-141-19      | 993204        |
| 1431-130-21            | 933421        | 3211-099-12            | 022003        | 4413-133-13            | 941413        | 9553-143-17      | 993203        |
| 1431-133-17            | 933417        | 3211-099-13            | 022005        | 4413-130-15            | 941415        | 9554-140-21      | 993215        |
| 1431-135-15            | 933415        | 3231-100-15            | 933015        | 4413-128-17            | 941417        | 9554-140-23      | 993216        |
| 1451-139-17            | 933417        | 3231-101-13            | 933013        | 4413-125-19            | 941419        | 9554-141-19      | 993214        |
| 1451-139-19            | 933419        | 3311-110-15            | 032040        | 5011-078-08            | 032055        | 9554-143-17      | 993213        |
| 1451-139-21            | 933421        | 3311-111-13            | 032042        | 5011-085-07            | 142102        | 9571-148-23      | 993026        |
| 1451-139-23            | 334135        | 3311-111-14            | 032041        | 5011-085-08            | 142103        | 9571-150-21      | 993025        |
| 1451-139-25            | 953424        | 3311-114-12            | 032043        | 5111-093-08            | 142203        | 9571-153-19      | 993024        |
| 1511-148-16            | 933515        | 3311-116-11            | 032044        | 5111-093-09            | 142204        | 9571-155-17      | 993023        |
| 1551-140-24            | 953524        | 3311-118-11            | 032044        | 5111-093-10            | 142205        | 9572-148-23      | 993036        |
| 1551-143-22            | 953522        | 3311-120-10            | 032045        | 5111-093-11            | 142206        | 9572-150-21      | 993035        |
| 1551-145-21            | 933521        | 3311-121-09            | 032045        | 5111-093-12            | 142207        | 9572-153-19      | 993034        |
| 1551-148-16            | 933515        | 3331-110-15            | 933215        | 5211-099-09 (Honda®)   | 111103        | 9572-155-17      | 993033        |
| 1551-148-17            | 933517        | 3331-111-13            | 993213        | 5211-099-09 (Tohatsu®) | 141304        | RBX-100          | XHS II 200    |
| 1551-148-19            | 933519        | 3411-130-19 (Yamaha®)  | 101034        | 5211-099-10 (Honda®)   | 111107        | RBX-101          | XHS II 201    |
| 1552-143-22            | 937523        | 3411-130-19 (Tohatsu®) | 142219        | 5211-099-10 (Tohatsu®) | 141307        | RBX-102          | XHS II 202    |
| 1552-145-21            | 937521        | 3411-130-21 (Yamaha®)  | 101135        | 5211-099-11 (Honda®)   | 111105        | RBX-103          | XHS II 203    |
| 1552-148-17            | 937517        | 3411-130-21 (Tohatsu®) | 142221        | 5211-099-11 (Tohatsu®) | 141305        | RBX-104          | XHS II 204    |
| 1552-148-19            | 937519        | 3411-133-17 (Yamaha®)  | 101033        | 5211-099-12 (Honda®)   | 111106        | RBX-105          | XHS II 205    |
| 1553-140-23            | 963523        | 3411-133-17 (Tohatsu®) | 142217        | 5211-099-12 (Tohatsu®) | 141308        | RBX-106          | XHS II 206    |
| 1553-140-25            | 963525        | 3411-135-15 (Yamaha®)  | 101032        | 5211-099-13 (Honda®)   | 111108        | RBX-107          | XHS II 207    |
| 2011-083-08P (Yamaha®) | 102002        | 3411-135-15 (Tohatsu®) | 142215        | 5211-099-13 (Tohatsu®) | 141306        | RBX-108          | XHS II 208    |
| 2011-083-08P (BRP®)    | 012008        | 3411-138-13 (Yamaha®)  | 101031        | 5311-121-09            | 142407        | RBX-109          | XHS II 209    |
| 2011-085-09            | 012007        | 3411-138-13 (Tohatsu®) | 142213        | 5311-118-10            | 142408        | RBX-110          | XHS II 210    |
| 2011-085-09P           | 012032        | 3411-139-17            | 061024        | 5311-116-11            | 142405        | RBX-111          | XHS 111       |
| 2111-090-10P           | 012015        | 3411-139-19            | 061028        | 5311-114-12            | 142409        | RBX-112          | XHS 112       |
| 2111-093-11P           | 012016        | 3411-139-21            | 061032        | 5311-111-13            | 142406        | RBX-113          | XHS 113       |
| 2111-093-07            | 012112        | 3411-140-11            | 101036        | 5311-111-14            | 142410        | RBX-114          | XHS 114       |
| 2111-093-10            | 012111        | 3413-133-13            | 941413        | 8611-142-23            | 161005        | RBX-115          | XHS 115       |
| 2111-093-11P           | 012013        | 3413-130-15            | 941415        | 8611-143-21            | 161004        | RBX-116          | XHS 116       |
| 2211-100-15            | 012057        | 3413-128-17            | 941417        | 8611-145-19            | 161003        | RBX-117          | XHS 117       |
| 2211-101-13            | 012056        | 3413-125-19            | 941419        | 8611-148-17            | 161002        | RBX-125          | XHS II 225    |
| 2211-105-11            | 012055        | 3431-130-21            | 933421        | 8611-150-15            | 161001        | RBX-126          | XHS II 226    |
| 2211-110-09            | 012054        | 3431-133-17            | 933317        | 8651-148-16            | 933515        | RBX-150          | XHS II 227    |
| 2231-100-15            | 933015        | 3431-135-15            | 933315        | 8651-148-17            | 933517        | RBX-151          | XHS II 228    |
| 2231-101-13            | 933013        | 3441-133-17            | 933417        | 8651-148-19            | 933519        |                  |               |
| 2311-120-17            | 011028        | 3441-133-19            | 933419        | 8651-148-21            | 933521        |                  |               |
| 2311-123-15            | 011027        | 3441-138-15            | 933415        | 8651-148-23            | 933523        |                  |               |
| 2311-125-13            | 012037        | 3511-145-19            | 101028        | 8652-148-17            | 937517        |                  |               |
| 2311-130-11            | 012036        | 3511-148-17            | 101027        | 8652-148-19            | 937519        |                  |               |
| 2411-130-19            | 011004        | 3551-140-24            | 933525        | 8652-148-23            | 937523        |                  |               |
| 2411-130-21            | 011105        | 3551-143-22            | 933523        | 9411-132-19            | 992115        |                  |               |
| 2411-133-17            | 011003        | 3551-145-21            | 933521        | 9411-132-21            | 992116        |                  |               |
| 2411-135-15            | 011002        | 3551-148-16            | 933515        | 9411-133-17            | 992114        |                  |               |
| 2411-138-13            | 011001        | 3551-148-17            | 937517        | 9411-135-15            | 992113        |                  |               |
| 2411-140-11            | 012047        | 3551-148-19            | 933519        | 9413-133-13            | 941413        |                  |               |
| 2413-133-13            | 941413        | 3552-145-21            | 937521        | 9413-130-15            | 941415        |                  |               |
| 2413-130-15            | 941415        | 3552-148-17            | 937517        | 9413-128-17            | 941417        |                  |               |
| 2413-128-17            | 941417        | 3552-148-19            | 937519        | 9413-125-19            | 941419        |                  |               |
| 2413-125-19            | 941419        | 3553-140-23            | 963523        | 9431-130-19            | 993145        |                  |               |

# QUICKSILVER® - MICHIGAN WHEEL CROSS REFERENCE

| Quicksilver®<br>Part # | MWM<br>Part # | Quicksilver®<br>Part # | MWM<br>Part # | Quicksilver®<br>Part # | MWM<br>Part # |
|------------------------|---------------|------------------------|---------------|------------------------|---------------|
| 48-33480A1             | 032135        | QA2080X                | 992407        | QA3122R                | 012057        |
| 48-47670A10            | 032020        | QA2084X                | 992408        | QA3136R                | 012016        |
| 48-47922A10            | 032021        | QA2102R                | 031049        | QA3150R                | 012011        |
| 48-8M8027498           | 941411        | QA2106R                | 031048        | QA3152R                | 012013        |
| 48-8M8027500           | 941413        | QA2124R                | 032056        | QA3168R                | 012111        |
| 48-8M8027502           | 941415        | QA2126R                | 032053        | QA3184R                | 032055        |
| 48-8M8027504           | 941417        | QA2128R                | 032052        | QA3190R                | 012032        |
| 48-8M8027506           | 941419        | QA2130R                | 032050        | QA3808R                | 022002        |
| 48-8M8027511           | 941212        | QA2158R                | 142203        | QA3812R                | 022003        |
| 48-8M8027512           | 941213        | QA2171R                | 142203        | QA3828X                | 992111        |
| 48-8M8027513           | 941214        | QA2173R                | 142204        | QA3832X                | 992112        |
| 48-8M8027514           | 941215        | QA2175R                | 142205        | QA3902R                | 102003        |
| 48-819335A40           | 072132        | QA2182X                | 992202        | QA3906R                | 102004        |
| 48-819336A40           | 072131        | QA2184X                | 992203        | QA3914R                | 102005        |
| 48-819337A45           | 072014        | QA2186X                | 992204        | QS5004X                | 993023        |
| 48-86962A4             | 032136        | QA2196R                | 141305        | QS5005X                | 993033        |
| 48-FP669-3             | 071035        | QA2202X                | 992116        | QS5006X                | 993024        |
| 48-FP685-3             | 071036        | QA2204X                | 992115        | QS5007X                | 993034        |
| 48-FP685-3             | 072128        | QA2206X                | 992114        | QS5008X                | 993025        |
| 48-FP686-4             | 992115        | QA2208X                | 992113        | QS5009X                | 993035        |
| 48-FP692-3             | 072127        | QA2226R (Mercury®)     | 032044        | QS5010X                | 993026        |
| 48-FP743-2             | 992112        | QA2226R (Suzuki®)      | 062211        | QS5011X                | 993036        |
| QA1912X                | 992003        | QA2230R                | 032042        | QS5050X                | 993042        |
| QA1916X                | 992004        | QA2232R (Mercury®)     | 032041        | QS5052X                | 993043        |
| QA1918X                | 992005        | QA2232R (Suzuki®)      | 062214        | QS5053X                | 993053        |
| QA1920X                | 992006        | QA2234R (Mercury®)     | 032040        | QS5054X                | 993044        |
| QA2002X                | 992001        | QA2234R (Suzuki®)      | 062215        | QS5055X                | 993054        |
| QA2008X                | 992002        | QA2238R (Suzuki®)      | 062217        | QS5056X                | 993045        |
| QA2028X                | 992111        | QA2242R                | 992501        | QS5057X                | 993055        |
| QA2032X                | 992112        | QA2248R                | 992503        | QS5058X                | 993046        |
| QA2034X                | 992113        | QA2252R                | 992504        | QS5059X                | 993056        |
| QA2036X                | 992114        | QA2254R                | 992505        | QS5164X                | 993405        |
| QA2038X                | 992115        | QA2828X                | 992111        | QS5166X                | 993406        |
| QA2040X                | 992116        | QA2832X                | 992112        | QS5168X                | 993407        |
| QA2062X                | 992601        | QA3080R                | 011034        | QS5170X                | 993408        |
| QA2064X                | 992602        | QA3080R                | 012036        | QA3084R                | 011027        |
| QA2070X                | 992404        | QA3082R                | 011035        | QA3088R                | 011028        |
| QA2074X                | 992405        | QA3082R                | 012037        | QA3114R                | 012055        |
| QA2078X                | 992406        | QA3118R                | 012056        |                        |               |

# MICHIGAN WHEEL XHS® / XHS II™ CROSS REFERENCE

## XHS® / XHS II® HUB SYSTEM CROSS REFERENCE TO EVINRUDE® TBX® HUB SYSTEM

| Applications  | Spline | Year         | Evinrude®<br>TBX® | XHS II®<br>Hub Kit |
|---|--------|--------------|-------------------|--------------------|
| Evinrude®/Johnson® V4 45-75 HP (4-1/4" Gearcase)                    | 13     | 1968 & Newer | 765195            | See Note 5         |
| Evinrude®/Johnson® V4 85-140 HP                                     | 13     | 1969 & Newer | 765195            | See Note 5         |
| Evinrude®/Johnson® 90, 115 HP (4-Stroke)                            | 15     | 2003 & Newer | 765199            | 225                |
| Evinrude®/Johnson® 90-140 HP (Large Gearcase)                       | 15     | 1991 & Newer | 765190            | 226                |
| Force® 75-150 HP  | 15     | 1995 & Newer | 765192            | 202                |
| Honda® 75-150 HP  | 15     | 1995-1998    | 765192            | 202                |
| Honda® 75-90 HP   | 15     | 1999 & Newer | 765196            | 207                |
| Honda® 115-130 HP   | 15     | 1999 & Newer | 765196            | 207                |
| Honda® BF 135 HP, 150 HP, 200 HP & 225 HP                           | 15     | 2003 & Newer | 765192            | 202                |
| Mercury®/Mariner®/MerCruiser® 60 HP Bigfoot                         | 15     |              | 765192            | 202                |
| Mercury®/Mariner®/MerCruiser® 70-140 HP (Except 135 HP), XR-4, XR-6 | 15     | 1961 & Newer | 765192            | 202                |
| Mercury®/Mariner®/MerCruiser® 135 HP                                | 15     | 1987 & Newer | 765192            | 202                |
| Mercury®/Mariner®/MerCruiser® 150-300 HP                            | 15     | 1978 & Newer | 765192            | 202                |
| Nissan®/Tohatsu® 90-140 HP  | 15     | 1987 & Newer | 765197            | 209                |
| Suzuki® DF90, DF115 HP (4-Stroke)                                   | 15     | 2001 & Newer | 765199            | 225                |
| Suzuki® DF140 (4-Stroke)  | 15     | 2001 & Newer | 765200            | 226                |
| Yamaha® 80-140 HP   | 15     | 1978-1983    | 765192            | 202                |
| Yamaha® 150-175 HP  | 15     | 1978-1983    | 765192            | 202                |
| Yamaha® 115 HP, FS115 (4-Stroke), 130 HP                            | 15     | 1984 & Newer | 765193            | 203                |
| Yamaha® 150-300 HP  | 15     | 1984 & Newer | 765193            | 203                |
| Yamaha® Sterndrives   | 15     | 1989-1993    | 765193            | 203                |
| OMC Cobra® SX Sterndrives   | 19     | 1994 & Newer | 765194            | 205                |
| Volvo Penta® SX Sterndrives   | 19     | 1994 & Newer | 765194            | 205                |

# MICHIGAN WHEEL XHS® / XHS II™ CROSS REFERENCE

## XHS® / XHS II® HUB SYSTEM CROSS REFERENCE TO MERCURY® FLO-TORQ® HUB SYSTEM

| Mercury® Flo-Torq® | XHS II® Hub Kit | Mercury® Flo-Torq® | XHS II® Hub Kit |
|--------------------|-----------------|--------------------|-----------------|
| 835257A1.....      | 202             | 835265Q02.....     | 200             |
| 835265A1.....      | 200             | 835266Q1.....      | 206             |
| 835266A1.....      | 206             | 835267Q1.....      | 201             |
| 835267A1.....      | 201             | 835270Q1.....      | 205             |
| 835270A1.....      | 205             | 835271Q2.....      | 203             |
| 835271A1.....      | 203             | 835272Q1.....      | 208             |
| 835272A1.....      | 208             | 835277Q1.....      | 202             |
| 835277A1.....      | 202             | 835279Q2.....      | 207             |
| 835278A1.....      | 207             | 835278Q1.....      | 207             |
| 835279A1.....      | 207             | 835281Q1.....      | 204             |
| 835281A1.....      | 204             | 835282Q1.....      | 210             |
| 835282A1.....      | 210             | 835283Q1.....      | 225             |
| 835284A1.....      | 209             | 835283Q2.....      | 226             |
| 835257K1.....      | 202             | 835283Q03.....     | 227             |
| 835257Q1.....      | 202             | 835284Q1.....      | 209             |

## XHS® / XHS II® HUB SYSTEM CROSS REFERENCE TO TURNING POINT® MASTERGUARD®/MASTERTORQUE® HUB SYSTEM

(MASTERGUARD® / MASTERTORQUE® HUB SYSTEMS NOT COMPATIBLE WITH MICHIGAN WHEEL XHS® PROPELLERS)

| Manufacturer/<br>Horsepower Range   | Turning Point®<br>MasterGuard® | XHS®<br>Hub Kit | Manufacturer/<br>Horsepower Range   | Turning Point®<br>MasterTorque® | XHS II®<br>Hub Kit |
|---|--------------------------------|-----------------|---|---------------------------------|--------------------|
| Evinrude®/Johnson®<br>20-35 HP • 3-1/4" Gearcase (Thru Hub & 14 Tooth)            | 22<br>1120 0200                | 118             | Evinrude®/Johnson®<br>90, 115, & 140 HP (4-Stroke) • 4-1/4" Gearcase (15 Tooth)       | 501 / 509<br>1150 0100/0900     | See Note 4         |
| Force®<br>25 HP • 3-1/4" Gearcase (Thru Hub & 10 Tooth)                           | 21<br>1120 0100                | 120             | Force®<br>75-150 HP • Using Mercury® 4-1/4" Gearcase (15 Tooth)                       | 501<br>1150 0100                | 202                |
| Mercury®/Mariner®<br>9.9-25 HP (Thru Hub & 10 Tooth)                              | 21<br>1120 0100                | 120             | Honda®<br>75-130 HP • 4-1/4" Gearcase (Thru Hub & 15 Tooth)                           | 501 / 507<br>1150 0100/0700     | See Note 3         |
| Honda®<br>25-30 HP • 3-1/4" Gearcase (Thru Hub & 10 Tooth)                        | 28<br>1120 0800                | 119             | Mercury®/Mariner®<br>40-140 HP • 4-1/4" Gearcase (Thru Hub & 15 Tooth)                | 501<br>1150 0100                | 202                |
| Mercury®/Mariner®<br>25-30 HP • Mercury 3-1/4" Gearcase (Thru Hub & 10 Tooth)     | 28<br>1120 0800                | 122             | Nissan®/Tohatsu®<br>60-140 HP • 4-1/4" Gearcase (Thru Hub & 15 Tooth)                 | 505<br>1150 0500                | 209                |
| Nissan®/Tohatsu®<br>25-30 HP • 3-1/4" Gearcase (Thru Hub & 10 Tooth)              | 28<br>1120 0800                | 122             | Suzuki®<br>70-140 HP (4-Stroke) • 4-1/4" Gearcase (15 Tooth)                          | 501 / 509<br>1150 0100/0900     | See Note 4         |
| Yamaha®<br>20-30 HP • 3-1/4" Gearcase (Thru Hub & 10 Tooth)                       | 25<br>1120 0500                | 123             | Yamaha®<br>50-130 HP • 4-1/4" Gearcase (Thru Hub & 15 Tooth)                          | 500 / 505<br>1150 0000/0500     | See Note 4         |
| Evinrude®/Johnson®<br>25-30 HP (4-Stroke) • 3-1/2" Gearcase (Thru Hub & 10 Tooth) | 26<br>1120 0600                | 121             | Evinrude®/Johnson®<br>40-75 HP • Large 4-1/4" Gearcase (Thru Hub & 13 Tooth)          | 503<br>1150 0300                | See Note 5         |
| Suzuki®<br>25-30 HP • 3-1/4" Gearcase (Thru Hub & 10 Tooth)                       | 26<br>1120 0600                | 121             | OMC® - Outboard Marine<br>Model 400, Cobra • 4-1/4" Gearcase (Thru Hub & 13 Tooth)    | 503<br>1150 0300                | 206                |
| Evinrude®/Johnson®<br>40-50 HP (4-Stroke) • 3-1/4" Gearcase (Thru Hub & 13 Tooth) | 11<br>1130 0100                | 115             | Suzuki®<br>60-140 HP • 4-1/4" Gearcase (Thru Hub & 13 Tooth)                          | 506<br>1150 0600                | 210                |
| Force®<br>40-75 HP • 3-1/4" Gearcase (Thru Hub & 13 Tooth)                        | 11<br>1130 0100                | 114             | Evinrude®/Johnson®<br>90-300 HP • V6 (4-3/4") Gearcase - Includes E-TEC Engines       | 502<br>1150 0200                | See Note 2         |
| Honda®<br>35-50 HP • 3-1/4" Gearcase (Thru Hub & 13 Tooth)                        | 12<br>1130 0200                | 113             | Honda®<br>135-225 HP • 4-3/4" Gearcase (Thru Hub & 15 Tooth)                          | 507<br>1150 0700                | 207                |
| Mercury®/Mariner®<br>25-70 HP • 3-1/4" Gearcase (Thru Hub & 13 Tooth)             | 11<br>1130 0100                | 114             | Mercury®/Mariner®/Mercruiser®<br>135-300 HP • V6 (4-3/4") Gearcase & Mercruiser I/O   | 501<br>1150 0100                | 202                |
| Nissan®/Tohatsu®<br>35-60 HP • 3-1/4" Gearcase (Thru Hub & 13 Tooth)              | 13<br>1130 0300                | 116             | OMC® - Outboard Marine<br>Model 800, King Cobra®, Cobra®, Sea Drive • 4-3/4" Gearcase | 502<br>1150 0200                | See Note 2         |
| Suzuki®<br>35-65 HP • 3-1/4" Gearcase (Thru Hub & 13 Tooth)                       | 11<br>1130 0100                | 115             | Suzuki®<br>150-300 HP • 4-3/4" Gearcase (Thru Hub & 15 Tooth)                         | 507<br>1150 0700                | 204                |
| Yamaha®<br>30-60 HP • 3-1/4" Gearcase (Thru Hub & 13 Tooth)                       | 12<br>1130 0200                | 111             | Volvo Penta®<br>SX Cobra®, Volvo Penta SX® • 4-3/4" Gearcase (19 Tooth)               | 504<br>1150 0400                | 205                |
| Evinrude®/Johnson®<br>40-75 HP • Small 3-3/8" Gearcase (Thru Hub & 13 Tooth)      | 12<br>1130 0200                | 111             | Yamaha®<br>150-300 HP & Yamaha® Sterndrives • 4-3/4" Gearcase                         | 505<br>1150 0500                | 203                |

# MICHIGAN WHEEL OEM CROSS REFERENCE

| Original Equipment Manufacturer<br>Part & Trade Mark | Standard<br>Hub<br>Propeller | XHS® / XHS II® Hub Propeller |                  |                |                 |                    |                    | XHS® / XHS II®<br>Hub Kit(s) | Catalog Page #s |
|--|------------------------------|------------------------------|------------------|----------------|-----------------|--------------------|--------------------|------------------------------|-----------------|
|  | Michigan<br>Match®           | Ballistic®                   | Ballistic®<br>XL | Vortex®<br>XHS | Apollo®<br>Std. | Apollo®<br>Lg. Dia | Apollo®<br>4-Blade |                              |                 |

**BRP®, EVINRUDE®, JOHNSON®, OMC®**

|        |                         |        |        |        |        |        |        |        |            |        |
|--------|-------------------------|--------|--------|--------|--------|--------|--------|--------|------------|--------|
| 174811 | VIPER™ (LH)             |        | 937519 |        |        | 993054 | 993034 | 993214 | See Note 2 | 11,50  |
| 174812 | VIPER™ (LH)             |        | 937521 |        |        | 993055 | 993035 | 993215 | See Note 2 | 11,50  |
| 174813 | VIPER™ (LH)             |        | 937523 |        |        | 993056 | 993036 | 993216 | See Note 2 | 11,50  |
| 174814 | VIPER™                  | 011008 | 933519 |        | 992004 | 993044 | 993024 | 993204 | See Note 2 | 11,50  |
| 174815 | VIPER™                  | 011009 | 933521 |        | 992005 | 993045 | 993025 | 993205 | See Note 2 | 11,50  |
| 174816 | VIPER™                  |        | 933523 |        | 992006 | 993046 | 993026 | 993206 | See Note 2 | 11,50  |
| 174889 | VIPER™                  | 011007 | 933517 |        | 992003 | 993043 | 993023 | 993203 | See Note 2 | 11,50  |
| 174890 | VIPER™ (LH)             |        | 937517 |        |        | 993053 | 993033 | 993213 | See Note 2 | 11,50  |
| 174926 | SST II®                 | 011006 | 933515 |        | 992002 | 993042 |        |        | See Note 2 | 11,50  |
| 174927 | SST II® (LH)            |        |        |        |        | 993052 |        |        | See Note 2 | 11,50  |
| 174950 |                         | 012111 |        |        |        |        |        |        |            | 2      |
| 175190 |                         | 012055 |        |        | 992503 |        |        | 118    |            | 4      |
| 175191 |                         | 012056 | 933013 |        | 992505 |        |        | 118    |            | 4      |
| 175738 | Renegade™ Bass          |        |        | 963525 |        |        |        |        | See Note 2 | 10,11  |
| 175739 | Renegade™ Bass          |        |        | 963527 |        |        |        |        | See Note 2 | 10,11  |
| 176058 | Renegade™ Bass          |        |        | 963523 |        |        |        |        | See Note 2 | 10,11  |
| 176196 | Renegade™ Bass          | 011105 |        | 953422 | 992116 | 993146 |        |        | See Note 5 | 6,7,49 |
| 176214 |                         | 011024 | 933417 |        | 992114 | 993144 |        |        | See Note 5 | 6,7,49 |
| 176215 |                         | 011025 | 933419 |        | 992115 | 993145 |        |        | See Note 5 | 6,7,49 |
| 176216 |                         | 011105 |        |        | 992116 | 993146 |        |        | See Note 5 | 6,7,49 |
| 176421 |                         | 011027 | 933315 |        | 992312 |        |        | 111    |            | 5      |
| 176422 |                         | 011028 | 933317 |        | 992303 |        |        | 111    |            | 5      |
| 176424 |                         |        |        |        | 992504 |        |        | 118    |            | 4      |
| 176425 |                         |        |        |        | 992506 |        |        | 118    |            | 4      |
| 176571 | SST II®                 | 011002 | 933415 |        | 992113 | 993143 |        |        | See Note 5 | 6,7,49 |
| 176572 | SST II®                 | 011003 | 933417 |        | 992114 | 993144 |        |        | See Note 5 | 6,7,49 |
| 176573 | SST II®                 | 011004 | 933419 |        | 992115 | 993145 |        |        | See Note 5 | 6,7,49 |
| 176574 | SST II®                 | 011105 |        | 953422 | 992116 | 993146 |        |        | See Note 5 | 6,7,49 |
| 176575 | Renegade™ O.S           | 011007 | 933517 |        | 992003 | 993043 | 993023 | 993203 | See Note 2 | 11,50  |
| 176576 | Renegade™ O.S           | 011008 | 933519 |        | 992004 | 993044 | 993024 | 993204 | See Note 2 | 11,50  |
| 176577 | Renegade™ O.S           | 011009 | 933521 |        | 992005 | 993045 | 993025 | 993205 | See Note 2 | 11,50  |
| 176578 | Renegade™ O.S (LH)      |        | 937517 |        |        | 993053 | 993033 | 993213 | See Note 2 | 11,50  |
| 176579 | Renegade™ O.S (LH)      |        | 937519 |        |        | 993054 | 993034 | 993214 | See Note 2 | 11,50  |
| 176580 | Renegade™ O.S (LH)      |        | 937521 |        |        | 993055 | 993035 | 993215 | See Note 2 | 11,50  |
| 176615 | Swept-Blade™            | 011007 | 933517 |        | 992003 | 993043 | 993023 | 993203 | See Note 2 | 11,50  |
| 176616 | Swept-Blade™ (LH)       |        | 937517 |        |        | 993053 | 993033 | 993213 | See Note 2 | 11,50  |
| 176617 | Swept-Blade™            | 011008 | 933519 |        | 992004 | 993044 | 993024 | 993204 | See Note 2 | 11,50  |
| 176618 | Swept-Blade™ (LH)       |        | 937519 |        |        | 993054 | 993034 | 993214 | See Note 2 | 11,50  |
| 176619 | Swept-Blade™            | 011009 | 933521 |        | 992005 | 993045 | 993025 | 993205 | See Note 2 | 11,50  |
| 176620 | Swept-Blade™ (LH)       |        | 937521 |        |        | 993055 | 993035 | 993215 | See Note 2 | 11,50  |
| 176623 | VIPER™                  | 011003 | 933417 |        | 992114 | 993144 |        |        | See Note 5 | 6,7,49 |
| 176624 | VIPER™                  | 011004 | 933419 |        | 992115 | 993145 |        |        | See Note 5 | 6,7,49 |
| 176625 | VIPER™                  | 011105 |        |        | 992116 | 993146 |        |        | See Note 5 | 6,7,49 |
| 176626 | VIPER™                  | 011007 | 933517 |        | 992003 | 993043 | 993023 | 993203 | See Note 2 | 11,50  |
| 176627 | VIPER™                  | 011008 | 933519 |        | 992004 | 993044 | 993024 | 993204 | See Note 2 | 11,50  |
| 176628 | VIPER™                  | 011009 | 933521 |        | 992005 | 993045 | 993025 | 993205 | See Note 2 | 11,50  |
| 176629 | VIPER™ (LH)             |        | 937517 |        |        | 993053 | 993033 | 993213 | See Note 2 | 11,50  |
| 176630 | VIPER™ (LH)             |        | 937519 |        |        | 993054 | 993034 | 993214 | See Note 2 | 11,50  |
| 176902 | VIPER™ (LH)             |        | 937521 |        |        | 993055 | 993035 | 993215 | See Note 2 | 11,50  |
| 176969 | SST®                    | 011008 | 933519 |        | 992004 | 993044 | 993024 | 993204 | See Note 2 | 11,50  |
| 176970 | SST®                    | 011008 | 933519 |        | 992004 | 993044 | 993024 | 993204 | See Note 2 | 11,50  |
| 176971 | SST®                    | 011009 | 933521 |        | 992005 | 993045 | 993025 | 993205 | See Note 2 | 11,50  |
| 176973 | SST® (LH)               |        |        |        |        | 993053 | 993033 | 993213 | See Note 2 | 11,50  |
| 176999 | Renegade™ O.S           |        | 933523 |        | 992006 | 993046 | 993026 | 993206 | See Note 2 | 11,50  |
| 177000 | Renegade™ O.S (LH)      |        |        |        |        | 993056 | 993036 | 993216 | See Note 2 | 11,50  |
| 177034 | SST®                    | 011002 | 933415 |        | 992113 | 993143 |        |        | See Note 5 | 6,7,49 |
| 177035 | SST®                    | 011003 | 933417 |        | 992114 | 993144 |        |        | See Note 5 | 6,7,49 |
| 177036 | SST®                    | 011004 | 933419 |        | 992115 | 993145 |        |        | See Note 5 | 6,7,49 |
| 177042 | VIPER™                  | 011002 | 933415 |        | 992113 | 993143 |        |        | See Note 5 | 6,7,49 |
| 177128 | Renegade™ Bass TBX™ (4) |        | 963523 |        |        |        |        |        | See Note 2 | 10,11  |
| 177129 | Renegade™ Bass TBX™ (4) |        | 963525 |        |        |        |        |        | See Note 2 | 10,11  |
| 177130 | Renegade™ Bass TBX™ (4) |        | 963527 |        |        |        |        |        | See Note 2 | 10,11  |
| 177131 |                         | 011024 | 933417 |        | 992114 | 993144 |        |        | See Note 5 | 6,7,49 |
| 177134 |                         | 011007 | 933517 |        | 992003 | 993043 | 993023 | 993203 | See Note 2 | 11,50  |
| 177135 |                         | 011008 | 933519 |        | 992004 | 993044 | 993024 | 993204 | See Note 2 | 11,50  |
| 177136 |                         | 011009 | 933521 |        | 992005 | 993045 | 993025 | 993205 | See Note 2 | 11,50  |
| 177137 |                         |        | 933523 |        | 992006 | 993046 | 993026 | 993206 | See Note 2 | 11,50  |
| 177139 |                         | 011025 | 933419 |        | 992115 | 993145 |        |        | See Note 5 | 6,7,49 |
| 177140 |                         |        | 335033 |        | 992116 | 993145 |        |        | See Note 5 | 6,7,49 |
| 177151 |                         | 011002 | 933415 |        | 992113 | 993143 |        |        | See Note 5 | 6,7,49 |
| 177153 |                         | 012037 |        |        | 992311 |        |        | 111    |            | 5      |
| 177159 |                         | 012111 |        |        |        |        |        |        |            | 3      |
| 177187 |                         | 012057 |        |        |        |        |        |        |            | 4      |

\* Indicates limited quantities.

# MICHIGAN WHEEL OEM CROSS REFERENCE

| Original Equipment Manufacturer<br>Part & Trade Mark | Standard<br>Hub<br>Propeller | XHS® / XHS II® Hub Propeller |                  |                |                 |                    |                    | XHS® / XHS II®<br>Hub Kit(s) | Catalog Page #s |
|--|------------------------------|------------------------------|------------------|----------------|-----------------|--------------------|--------------------|------------------------------|-----------------|
|  | Michigan<br>Match®           | Ballistic®                   | Ballistic®<br>XL | Vortex®<br>XHS | Apollo®<br>Std. | Apollo®<br>Lg. Dia | Apollo®<br>4-Blade |                              |                 |

**BRP®, EVINRUDE®, JOHNSON®, OMC® (Continued)**

|             |             |        |        |  |        |        |        |            |            |        |
|-------------|-------------|--------|--------|--|--------|--------|--------|------------|------------|--------|
| 177258..... | VIPER™      | 011002 | 933415 |  | 992113 | 993143 |        | See Note 5 | 6          |        |
| 177259..... | VIPER™      | 011003 | 933417 |  | 992114 | 993144 |        | See Note 5 | 6          |        |
| 177265..... | Raker II®   |        | 953524 |  |        |        |        |            | 11,50      |        |
| 177266..... | Raker II®   |        | 953526 |  |        |        |        |            | 11,50      |        |
| 178811..... | VIPER™ (LH) |        |        |  |        | 993054 | 993034 | 993214     | See Note 2 | 11,50  |
| 178814..... | VIPER™      | 011008 |        |  | 992004 | 993044 | 993024 | 993204     | See Note 2 | 11,50  |
| 277212..... |             | 012011 |        |  |        |        |        |            |            | 3      |
| 277443..... |             | 012011 |        |  |        |        |        |            |            | 3      |
| 277580..... |             | 012024 |        |  |        |        |        |            |            | 4      |
| 277581..... |             | 012024 |        |  |        |        |        |            |            | 4      |
| 277583..... |             | 012011 |        |  |        |        |        |            |            | 3      |
| 277599..... |             | 012011 |        |  |        |        |        |            |            | 3      |
| 277759..... |             | 012008 |        |  |        |        |        |            |            | 2      |
| 375605..... |             | 012109 |        |  |        |        |        |            |            | 3      |
| 376506..... |             | 012011 |        |  |        |        |        |            |            | 3      |
| 376732..... |             | 012024 |        |  |        |        |        |            |            | 4      |
| 376735..... |             | 012109 |        |  |        |        |        |            |            | 3      |
| 376737..... |             | 012011 |        |  |        |        |        |            |            | 3      |
| 376805..... |             | 012011 |        |  |        |        |        |            |            | 3      |
| 376841..... |             | 012109 |        |  |        |        |        |            |            | 3      |
| 377410..... |             | 012023 |        |  |        |        |        |            |            | 4      |
| 377635..... |             | 012007 |        |  |        |        |        |            |            | 2      |
| 377636..... |             | 012011 |        |  |        |        |        |            |            | 3      |
| 378581..... |             | 012023 |        |  |        |        |        |            |            | 3      |
| 379717..... |             | 012109 |        |  |        |        |        |            |            | 3      |
| 380637..... |             | 012024 |        |  |        |        |        |            |            | 3      |
| 380958..... |             | 012005 |        |  |        |        |        |            |            | 2      |
| 381185..... |             | 012091 |        |  |        |        |        |            |            | 46     |
| 381186..... |             | 012092 |        |  |        |        |        |            |            | 46     |
| 381801..... |             | 012011 |        |  |        |        |        |            |            | 3      |
| 382761..... |             | 012047 |        |  |        |        |        |            |            | 6,7,49 |
| 382762..... |             | 011001 |        |  | 992112 |        |        |            | See Note 5 | 6,7,49 |
| 382763..... |             | 011002 | 933415 |  | 992113 | 993143 |        |            | See Note 5 | 6,7,49 |
| 382764..... |             | 011003 | 933417 |  | 992114 | 993144 |        |            | See Note 5 | 6,7,49 |
| 382765..... |             | 011004 | 933419 |  | 992115 | 993145 |        |            | See Note 5 | 6,7,49 |
| 382766..... |             | 011105 |        |  | 992116 | 993146 |        |            | See Note 5 | 6,7,49 |
| 382768..... |             | 011105 |        |  | 992116 | 993146 |        |            | See Note 5 | 6,7,49 |
| 383315..... |             | 012008 |        |  |        |        |        |            |            | 2      |
| 383629..... |             | 012015 |        |  |        |        |        |            |            | 3      |
| 384139..... | SST®        | 011003 | 933417 |  | 992114 | 993144 |        |            | See Note 5 | 6,7,49 |
| 384140..... | SST®        | 011105 |        |  | 992116 | 993146 |        |            | See Note 5 | 6,7,49 |
| 384141..... | SST®        | 011105 |        |  | 992116 | 993146 |        |            | See Note 5 | 6,7,49 |
| 384142..... | SST®        | 011004 | 933419 |  | 992115 | 993145 |        |            | See Note 5 | 6,7,49 |
| 384144..... | SST®        | 011002 | 933415 |  | 992113 | 993143 |        |            | See Note 5 | 6,7,49 |
| 384702..... | SST®        | 011105 |        |  | 992116 | 993146 |        |            | See Note 5 | 6,7,49 |
| 385319..... |             | 012005 |        |  |        |        |        |            |            | 2      |
| 385940..... | SST®        | 012008 |        |  |        |        |        |            |            | 2      |
| 385955..... |             | 012023 |        |  |        |        |        |            |            | 3      |
| 386118..... |             | 012111 |        |  |        |        |        |            |            | 3      |
| 386317..... |             | 012054 |        |  | 992501 |        |        | 118        |            | 4      |
| 386637..... |             | 012055 |        |  | 992503 |        |        | 118        |            | 4      |
| 986786..... |             | 011027 | 933315 |  | 992311 |        |        | 111        |            | 5      |
| 386841..... |             | 011028 |        |  | 992312 |        |        | 111        |            | 5      |
| 386907..... |             | 012036 |        |  |        |        |        |            |            | 5      |
| 386909..... |             | 012037 |        |  | 992301 |        |        | 111        |            | 5      |
| 386933..... |             | 012056 |        |  | 992505 |        |        | 118        |            | 4      |
| 386955..... |             | 012005 |        |  |        |        |        |            |            | 2      |
| 386980..... | SST®        | 011028 | 933317 |  | 992303 |        |        | 111        |            | 5      |
| 386981..... | SST®        | 011027 | 933315 |  | 992312 |        |        | 111        |            | 5      |
| 386982..... | SST®        | 011035 |        |  | 992311 |        |        | 111        |            | 5      |
| 387158..... |             | 011016 |        |  | 992001 |        |        |            | See Note 2 | 11,50  |
| 387159..... |             | 011006 | 933515 |  | 992002 | 993042 |        |            | See Note 2 | 11,50  |
| 387160..... |             | 011007 | 933517 |  | 992003 | 993043 | 993023 | 993203     | See Note 2 | 11,50  |
| 387161..... |             | 011008 | 933519 |  | 992004 | 993044 | 993024 | 993204     | See Note 2 | 11,50  |
| 387162..... |             | 011009 | 933521 |  | 992005 | 993045 | 993025 | 993205     | See Note 2 | 11,50  |
| 387163..... |             |        | 933523 |  | 992006 | 993046 | 993026 | 993206     | See Note 2 | 11,50  |
| 387334..... |             | 012008 |        |  |        |        |        |            |            | 2      |
| 387519..... | SST®        | 011008 | 933519 |  | 992004 | 993044 | 993024 | 993204     | See Note 2 | 11,50  |
| 387520..... | SST®        | 011009 | 933521 |  | 992005 | 993045 | 993025 | 993205     | See Note 2 | 11,50  |
| 387636..... |             | 012056 |        |  |        |        |        |            |            | 4      |
| 388088..... |             | 012013 |        |  |        |        |        |            |            | 3      |
| 388294..... |             | 012102 |        |  |        |        |        |            |            | 3      |
| 388883..... |             | 012016 |        |  |        |        |        |            |            | 3      |

\* Indicates limited quantities.



# MICHIGAN WHEEL OEM CROSS REFERENCE

| Original Equipment Manufacturer<br>Part & Trade Mark | Standard<br>Hub<br>Propeller | XHS® / XHS II® Hub Propeller |                  |                |                 |                    |                    | XHS® / XHS II®<br>Hub Kit(s) | Catalog Page #s |
|--|------------------------------|------------------------------|------------------|----------------|-----------------|--------------------|--------------------|------------------------------|-----------------|
|  | Michigan<br>Match®           | Ballistic®                   | Ballistic®<br>XL | Vortex®<br>XHS | Apollo®<br>Std. | Apollo®<br>Lg. Dia | Apollo®<br>4-Blade |                              |                 |

**BRP®, EVINRUDE®, JOHNSON®, OMC® (Continued)**

|        |              |        |        |        |        |        |        |        |            |        |
|--------|--------------|--------|--------|--------|--------|--------|--------|--------|------------|--------|
| 389019 | SST II®      |        | 933523 |        |        | 993046 | 993026 | 993206 | See Note 2 | 11,50  |
| 389068 |              | 012021 |        |        |        |        |        |        |            | 3      |
| 389069 |              | 012015 |        |        |        |        |        |        |            | 3      |
| 389510 | SST II®      | 011004 | 933419 |        | 992115 | 993145 |        |        | See Note 5 | 6,7,49 |
| 389512 | SST II®      | 011105 |        |        | 992116 | 993146 |        |        | See Note 5 | 6,7,49 |
| 389619 |              | 012015 |        |        |        |        |        |        |            | 3      |
| 389788 |              | 011105 | 953422 |        | 992116 | 993146 |        |        | See Note 5 | 6,7,49 |
| 389855 |              | 012023 |        |        |        |        |        |        |            | 3      |
| 389923 | SST II®      | 011009 | 933521 |        | 992005 | 993045 | 993025 | 993205 | See Note 2 | 11,50  |
| 389924 | SST II®      | 011008 | 933519 |        | 992004 | 993044 | 993024 | 993204 | See Note 2 | 11,50  |
| 389925 | SST II®      | 011007 | 933517 |        | 992003 | 993043 | 993023 | 993203 | See Note 2 | 11,50  |
| 389944 |              | 012030 |        |        |        |        |        |        |            | 3      |
| 389948 | SST II®      | 011003 | 933417 |        | 992114 | 993144 |        |        | See Note 5 | 6,7,49 |
| 389949 | SST II®      | 011002 | 933415 |        | 992113 | 993143 |        |        | See Note 5 | 6,7,49 |
| 390113 | SST®         | 011004 | 933419 |        | 992115 | 993145 |        |        | See Note 5 | 6,7,49 |
| 390114 | SST®         | 011003 | 933417 |        | 992114 | 993144 |        |        | See Note 5 | 6,7,49 |
| 390237 |              | 012032 |        |        |        |        |        |        |            | 2      |
| 390380 |              | 012057 | 933015 |        |        |        |        |        |            | 4      |
| 390725 | SST®         |        | 933525 |        |        |        |        |        |            | 11,50  |
| 390729 | SST®         |        | 933013 |        |        |        |        |        |            | 4      |
| 390730 | SST®         |        | 933015 |        |        |        |        |        |            | 4      |
| 390821 | SST II® (LH) |        | 937519 |        |        | 993054 | 993034 | 993214 | See Note 2 | 11,50  |
| 390822 | SST II® (LH) |        | 937521 |        |        | 993055 | 993035 | 993215 | See Note 2 | 11,50  |
| 390823 | SST II® (LH) |        | 937523 |        |        | 993056 | 993036 | 993216 | See Note 2 | 11,50  |
| 390833 |              | 012024 |        |        |        |        |        |        |            | 3      |
| 390849 | SST®         | 011035 |        |        | 992311 |        |        |        | 111        | 5      |
| 390850 | SST®         | 011027 | 933315 |        | 992312 |        |        |        | 111        | 5      |
| 390851 | SST®         | 011028 | 933317 |        | 992303 |        |        |        | 111        | 5      |
| 390896 |              | 011004 | 933419 |        | 992115 | 993145 |        |        | See Note 5 | 6,7,49 |
| 391198 |              | 011002 | 933415 |        | 992113 | 993143 |        |        | See Note 5 | 6,7,49 |
| 391199 |              | 011003 | 933417 |        | 992114 | 993144 |        |        | See Note 5 | 6,7,49 |
| 391200 |              | 011007 | 933517 |        | 992003 | 993043 | 993023 | 993203 | See Note 2 | 11,50  |
| 391201 |              | 011008 | 933519 |        | 992004 | 993044 | 993024 | 993204 | See Note 2 | 11,50  |
| 391202 |              | 011009 | 933521 | 953522 | 992005 | 993045 | 993025 | 993205 | See Note 2 | 11,50  |
| 391203 |              |        | 933523 | 953524 | 992006 | 993046 | 993026 | 993206 | See Note 2 | 11,50  |
| 391290 | SST II®      | 011007 | 933517 |        | 992003 | 993043 | 993023 | 993203 | See Note 2 | 11,50  |
| 391535 |              | 011006 | 933515 |        | 992002 | 993042 | 993022 |        | See Note 2 | 11,50  |
| 391536 |              | 011016 |        |        | 992001 |        |        |        | See Note 2 | 11,50  |
| 391668 |              | 011001 |        |        |        |        |        |        |            | 6,7,49 |
| 393160 |              | 011025 |        |        | 992115 | 993145 |        |        | See Note 5 | 6,7,49 |
| 394752 | Raker®       | 011007 | 933517 |        | 992003 | 993043 |        | 993203 | See Note 2 | 11,50  |
| 394753 | Raker®       | 011008 | 933519 |        | 992004 | 993044 |        | 993204 | See Note 2 | 11,50  |
| 394754 | Raker®       | 011009 | 933521 | 953522 | 992005 | 993045 |        | 993205 | See Note 2 | 11,50  |
| 394755 | Raker®       |        | 933523 | 953524 | 992006 | 993046 |        | 993206 | See Note 2 | 11,50  |
| 394756 | Raker®       |        | 933525 | 953526 |        |        |        |        |            | 11,50  |
| 394758 | Raker®       | 011003 | 933417 |        | 992114 | 993144 |        |        | See Note 5 | 6,7,49 |
| 394759 | Raker®       | 011004 | 933419 |        | 992115 | 993145 |        |        | See Note 5 | 6,7,49 |
| 394760 | Raker®       | 011105 |        | 953422 | 992115 | 993146 |        |        | See Note 5 | 6,7,49 |
| 394761 | Raker®       |        |        | 953424 |        |        |        |        |            | 7      |
| 398126 |              | 012112 |        |        |        |        |        |        |            | 2      |
| 398502 | Raker® (LH)  |        | 937519 |        |        | 993054 |        | 993214 | See Note 2 | 11,50  |
| 398503 | Raker® (LH)  |        | 937521 |        |        | 993055 |        | 993215 | See Note 2 | 11,50  |
| 398504 | Raker® (LH)  |        |        |        |        | 993056 |        | 993216 | See Note 2 | 11,50  |
| 431717 | Shooter®     |        | 963523 |        |        |        |        |        |            | 10,11  |
| 431718 | Shooter®     |        | 963525 |        |        |        |        |        |            | 10,11  |
| 431930 | SST II® (LH) |        | 937517 |        |        | 993053 |        | 993213 | See Note 2 | 11,50  |
| 591920 |              | 012024 |        |        |        |        |        |        |            | 3      |
| 591925 |              | 012011 |        |        |        |        |        |        |            | 3      |
| 592038 |              | 012011 |        |        |        |        |        |        |            | 3      |
| 592959 |              | 012011 |        |        |        |        |        |        |            | 3      |
| 763301 |              | 012047 |        |        |        |        |        |        |            | 6,7,49 |
| 763302 |              | 011001 |        |        | 992112 |        |        |        | See Note 5 | 6,7,49 |
| 763304 |              |        | 933515 |        | 992002 | 993042 | 993022 |        | 205        | 51     |
| 763305 |              |        |        |        |        | 993052 | 993032 |        | 205        | 51     |
| 763306 |              | 161002 | 933517 |        | 992003 | 993043 | 993023 | 993203 | 205        | 51     |
| 763307 |              |        | 937517 |        |        | 993053 | 993033 | 993213 | 205        | 51     |
| 763308 |              | 161003 | 933519 |        | 992004 | 993044 | 993024 | 993204 | 205        | 51     |
| 763309 |              |        |        |        |        | 993054 | 993034 | 993214 | 205        | 51     |
| 763310 |              | 161004 | 933521 |        | 992005 | 993045 | 993025 | 993205 | 205        | 51     |
| 763311 |              |        | 937521 |        |        | 993055 | 993035 | 993215 | 205        | 51     |
| 763315 |              | 161001 | 933515 |        | 992002 | 993042 | 993022 |        | 205        | 51     |
| 763316 |              | 161002 | 933517 |        | 992003 | 993043 | 993023 | 993203 | 205        | 51     |
| 763317 |              | 161003 | 933519 |        | 992004 | 993044 | 993024 | 993204 | 205        | 51     |

\* Indicates limited quantities.

# MICHIGAN WHEEL OEM CROSS REFERENCE

| Original Equipment Manufacturer<br>Part & Trade Mark | Standard<br>Hub<br>Propeller | XHS® / XHS II® Hub Propeller |                  |                |                 |                    |                    | XHS® / XHS II®<br>Hub Kit(s) | Catalog Page #s |
|--|------------------------------|------------------------------|------------------|----------------|-----------------|--------------------|--------------------|------------------------------|-----------------|
|  | Michigan<br>Match®           | Ballistic®                   | Ballistic®<br>XL | Vortex®<br>XHS | Apollo®<br>Std. | Apollo®<br>Lg. Dia | Apollo®<br>4-Blade |                              |                 |

### BRP®, EVINRUDE®, JOHNSON®, OMC® (Continued)

|             |                             |             |             |             |             |             |                 |                 |       |
|-------------|-----------------------------|-------------|-------------|-------------|-------------|-------------|-----------------|-----------------|-------|
| 763318..... | 161004.....                 | 933521..... | 992005..... | 993045..... | 993025..... | 993205..... | 205.....        | 51              |       |
| 763319..... | 161005.....                 | 933523..... | 992006..... | 993046..... | 993026..... | 993206..... | 205.....        | 51              |       |
| 763453..... | 011016.....                 |             | 992001..... |             |             |             | See Note 2..... | 11,50           |       |
| 763456..... | 012112.....                 |             |             |             |             |             |                 | 2               |       |
| 763459..... | 012055.....                 |             | 992503..... |             |             |             | 118.....        | 4               |       |
| 763460..... |                             |             | 992504..... |             |             |             | 118.....        | 4               |       |
| 763461..... | 012037.....                 |             | 992311..... |             |             |             | 111.....        | 5               |       |
| 763462..... | 011028.....                 | 933317..... | 992303..... |             |             |             | 111.....        | 5               |       |
| 763463..... | 011003.....                 | 933417..... | 992114..... | 993144..... |             |             | See Note 5..... | 6,7,49          |       |
| 763464..... | 011004.....                 | 933419..... | 992115..... | 993145..... |             |             | See Note 5..... | 6,7,49          |       |
| 763465..... | 011105.....                 |             | 992116..... | 993146..... |             |             | See Note 5..... | 6,7,49          |       |
| 763466..... | 011002.....                 | 933415..... | 992113..... | 993143..... |             |             | See Note 5..... | 6,7,49          |       |
| 763467..... | 011007.....                 | 933517..... | 992003..... | 993043..... | 993023..... | 993203..... | See Note 2..... | 11,50           |       |
| 763468..... | 011008.....                 | 933519..... | 992004..... | 993044..... | 993024..... | 993204..... | See Note 2..... | 11,50           |       |
| 763469..... | 011009.....                 | 933521..... | 992005..... | 993045..... | 993025..... | 993205..... | See Note 2..... | 11,50           |       |
| 763470..... |                             | 933523..... | 992006..... | 993046..... | 993026..... | 993206..... | See Note 2..... | 11,50           |       |
| 763471..... | 011006.....                 | 933515..... | 992002..... | 993042..... |             |             | See Note 2..... | 11,50           |       |
| 763486..... | 012057.....                 | 933015..... |             |             |             |             |                 | 4               |       |
| 763487..... | 012054.....                 |             | 992501..... |             |             |             | 118.....        | 4               |       |
| 763488..... | 012036.....                 |             |             |             |             |             |                 | 5               |       |
| 763568..... | Rebel™.....                 | 933517..... | 992003..... | 993043..... | 993023..... | 993203..... | See Note 2..... | 11,50           |       |
| 763569..... | Rebel™ (LH).....            | 937517..... |             | 993053..... | 993033..... | 993213..... | See Note 2..... | 11,50           |       |
| 763570..... | Rebel™.....                 | 933519..... | 992004..... | 993044..... | 993024..... | 993204..... | See Note 2..... | 11,50           |       |
| 763571..... | Rebel™ (LH).....            | 937519..... |             | 993054..... | 993034..... | 993214..... | See Note 2..... | 11,50           |       |
| 763572..... | Rebel™.....                 | 933521..... | 992005..... | 993045..... | 993025..... | 993205..... | See Note 2..... | 11,50           |       |
| 763573..... | Rebel™ (LH).....            | 937521..... |             | 993055..... | 993035..... | 993215..... | See Note 2..... | 11,50           |       |
| 763574..... | Rebel™.....                 | 933523..... | 992006..... | 993046..... | 993026..... | 993206..... | See Note 2..... | 11,50           |       |
| 763575..... | Rebel™ (LH).....            |             |             | 993056..... | 993036..... | 993216..... | See Note 2..... | 11,50           |       |
| 763583..... |                             | 012011..... |             |             |             |             |                 | 3               |       |
| 763584..... |                             | 012016..... |             |             |             |             |                 | 3               |       |
| 763585..... |                             | 012021..... |             |             |             |             |                 | 3               |       |
| 763586..... |                             | 012007..... |             |             |             |             |                 | 2               |       |
| 763587..... |                             | 012109..... |             |             |             |             |                 | 3               |       |
| 763588..... |                             | 012005..... |             |             |             |             |                 | 2               |       |
| 763589..... |                             | 012015..... |             |             |             |             |                 | 3               |       |
| 763590..... |                             | 012030..... |             |             |             |             |                 | 3               |       |
| 763912..... | VIPER™ TBX™.....            | 933515..... |             | 993042..... |             |             | See Note 2..... | 11,50           |       |
| 763913..... | VIPER™ TBX™ (LH).....       |             |             | 993052..... |             |             | See Note 2..... | 11,50           |       |
| 763914..... | VIPER™ TBX™.....            | 011007..... | 933517..... | 992003..... | 993043..... | 993023..... | 993203.....     | See Note 2..... | 11,50 |
| 763915..... | VIPER™ TBX™ (LH).....       |             | 937517..... | 993053..... | 993033..... | 993213..... | See Note 2..... | 11,50           |       |
| 763918..... | VIPER™ TBX™.....            | 011008..... | 933519..... | 992004..... | 993044..... | 993024..... | 993204.....     | See Note 2..... | 11,50 |
| 763919..... | VIPER™ TBX™ (LH).....       |             | 937519..... | 993054..... | 993034..... | 993214..... | See Note 2..... | 11,50           |       |
| 763922..... | VIPER™ TBX™.....            | 011009..... | 933521..... | 992005..... | 993045..... | 993025..... | 993205.....     | See Note 2..... | 11,50 |
| 763923..... | VIPER™ TBX™ (LH).....       |             | 937521..... | 993055..... | 993035..... | 993215..... | See Note 2..... | 11,50           |       |
| 763929..... | VIPER™ 3.....               | 011002..... | 933415..... | 992113..... | 993143..... |             | See Note 5..... | 6               |       |
| 763930..... | VIPER™ 3.....               | 011003..... | 933417..... | 992114..... | 993144..... |             | See Note 5..... | 6               |       |
| 763931..... | VIPER™ 3.....               | 011004..... | 933419..... | 992115..... | 993145..... |             | See Note 5..... | 6               |       |
| 763932..... | VIPER™ 3.....               | 011105..... |             | 992116..... | 993146..... |             | See Note 5..... | 6               |       |
| 763938..... | Cyclone™ TBX™ 4.....        |             |             | 992202..... |             | 993203..... | See Note 2..... | 11,50           |       |
| 763939..... | Cyclone™ TBX™ 4 (LH).....   |             |             |             |             | 993213..... | See Note 2..... | 11,50           |       |
| 763940..... | Cyclone™ TBX™ 4.....        |             |             | 992203..... |             | 993204..... | See Note 2..... | 11,50           |       |
| 763941..... | Cyclone™ TBX™ 4 (LH).....   |             |             |             |             | 993214..... | See Note 2..... | 11,50           |       |
| 763944..... | Cyclone™ TBX™ 4.....        |             |             | 992204..... |             | 993205..... | See Note 2..... | 11,50           |       |
| 763945..... | Cyclone™ TBX™ 4 (LH).....   |             |             |             |             | 993215..... | See Note 2..... | 11,50           |       |
| 763950..... |                             | 011002..... | 933415..... | 992113..... | 993143..... |             | See Note 5..... | 6,7             |       |
| 763951..... |                             | 011003..... | 933417..... | 992114..... | 993144..... |             | See Note 5..... | 6,7             |       |
| 763952..... |                             | 011004..... | 933419..... | 992115..... | 993145..... |             | See Note 5..... | 6,7             |       |
| 763956..... | Raker®.....                 | 953424..... |             |             |             | 206.....    |                 | 7               |       |
| 763962..... | SST® TBX™.....              | 933515..... | 992002..... | 993042..... |             |             | See Note 2..... | 11,50           |       |
| 763963..... | SST® TBX™ (LH).....         |             |             | 993052..... |             |             | See Note 2..... | 11,50           |       |
| 763964..... | Rogue™ Stainless Steel..... |             |             | 941413..... |             |             | See Note 5..... | 6,7,8           |       |
| 763965..... | Rogue™ Stainless Steel..... |             |             | 941415..... |             |             | See Note 5..... | 6,7,8           |       |
| 763966..... | Rogue™ Stainless Steel..... |             |             | 941417..... |             |             | See Note 5..... | 6,7,8           |       |
| 763967..... | Rogue™ Stainless Steel..... |             |             | 941419..... |             |             | See Note 5..... | 6,7,8           |       |
| 763986..... | Rebel™ TBX™.....            | 011007..... | 933517..... | 992003..... | 993043..... | 993023..... | 993203.....     | See Note 2..... | 11,50 |
| 763987..... | Rebel™ TBX™ (LH).....       |             | 937517..... | 993053..... | 993033..... | 993213..... | See Note 2..... | 11,50           |       |
| 763990..... | Rebel™ TBX™.....            | 011008..... | 933519..... | 992004..... | 993044..... | 993024..... | 993204.....     | See Note 2..... | 11,50 |
| 763991..... | Rebel™ TBX™ (LH).....       |             | 937519..... | 993054..... | 993034..... | 993214..... | See Note 2..... | 11,50           |       |
| 763994..... | Rebel™ TBX™.....            | 011009..... | 933521..... | 992005..... | 993045..... | 993025..... | 993205.....     | See Note 2..... | 11,50 |
| 763995..... | Rebel™ TBX™ (LH).....       |             | 937519..... | 993055..... | 993035..... | 993215..... | See Note 2..... | 11,50           |       |
| 763998..... | Rebel™ TBX™.....            | 933523..... | 992006..... | 993046..... | 993026..... | 993206..... | See Note 2..... | 11,50           |       |
| 763999..... | Rebel™ TBX™ (LH).....       |             |             | 993056..... | 993036..... | 993216..... | See Note 2..... | 11,50           |       |
| 765048..... | Aluminum.....               | 012054..... |             | 992501..... |             |             | 118.....        | 4               |       |

\* Indicates limited quantities.

# MICHIGAN WHEEL OEM CROSS REFERENCE

| Original Equipment Manufacturer<br>Part & Trade Mark | Standard<br>Hub<br>Propeller | XHS® / XHS II® Hub Propeller |                  |                |                 |                    |                    | XHS® / XHS II®<br>Hub Kit(s) | Catalog Page #s |
|--|------------------------------|------------------------------|------------------|----------------|-----------------|--------------------|--------------------|------------------------------|-----------------|
|  | Michigan<br>Match®           | Ballistic®                   | Ballistic®<br>XL | Vortex®<br>XHS | Apollo®<br>Std. | Apollo®<br>Lg. Dia | Apollo®<br>4-Blade |                              |                 |

### BRP®, EVINRUDE®, JOHNSON®, OMC® (Continued)

|         |                  |        |        |  |  |  |  |        |            |            |
|---------|------------------|--------|--------|--|--|--|--|--------|------------|------------|
| 765049  | Aluminum         | 012055 |        |  |  |  |  | 992503 | 118        | 4          |
| 765050  | Aluminum         |        |        |  |  |  |  | 992504 | 118        | 4          |
| 765176  | SSP              | 012055 |        |  |  |  |  | 992503 | 118        | 4          |
| 765178  | SSP              |        | 933013 |  |  |  |  |        | 118        | 4          |
| 765180  | SSP              |        | 933015 |  |  |  |  |        | 118        | 4          |
| 765181  |                  | 011001 |        |  |  |  |  | 992112 | See Note 5 | 6,7,49     |
| 765182  |                  |        |        |  |  |  |  | 992113 | 993143     | See Note 5 |
| 765183  |                  |        |        |  |  |  |  | 992114 | 993144     | See Note 5 |
| 765184  |                  |        |        |  |  |  |  | 992115 | 993145     | See Note 5 |
| 765185  |                  |        |        |  |  |  |  | 992116 | 993146     | See Note 5 |
| 765186  |                  |        | 933515 |  |  |  |  | 992002 | 993042     | See Note 2 |
| 765187  |                  | 011007 | 933517 |  |  |  |  | 992003 | 993043     | 993023     |
| 765188  |                  | 011008 | 933519 |  |  |  |  | 992004 | 993044     | 993024     |
| 765189  |                  | 011009 | 933521 |  |  |  |  | 992005 | 993045     | 993025     |
| 775713  |                  | 012037 |        |  |  |  |  | 992311 | 111        | 5          |
| 776807  |                  | 032046 |        |  |  |  |  |        |            | 5          |
| 776891  |                  | 011001 |        |  |  |  |  | 992112 | See Note 5 | 6,7,49     |
| 777021  | SST® High Luster | 032042 | 993213 |  |  |  |  | 992605 | 993406     | 115        |
| 777022  | SST® High Luster | 032041 |        |  |  |  |  | 992606 | 993407     | 115        |
| 777023  | SST® High Luster | 032040 | 933215 |  |  |  |  | 992408 | 993408     | 115        |
| 777024  |                  | 061024 |        |  |  |  |  | 992114 | 993144     | See Note 4 |
| 777025  |                  | 061028 |        |  |  |  |  | 992115 | 993145     | See Note 4 |
| 777026  |                  | 061032 |        |  |  |  |  | 992116 | 993146     | See Note 4 |
| 777029  |                  |        |        |  |  |  |  | 993154 |            | See Note 4 |
| 777030  |                  |        |        |  |  |  |  | 993155 |            | See Note 4 |
| 777031  |                  |        |        |  |  |  |  | 993156 |            | See Note 4 |
| 778703  |                  |        |        |  |  |  |  | 992503 | 121        | 4          |
| 778704  |                  |        |        |  |  |  |  | 992504 | 121        | 4          |
| 778705  |                  |        | 933013 |  |  |  |  | 992505 | 121        | 4          |
| 778706  |                  |        |        |  |  |  |  | 992506 | 121        | 4          |
| 778738  |                  | 061020 |        |  |  |  |  |        |            | 8          |
| 778739  |                  | 061024 |        |  |  |  |  |        |            | 8          |
| 778740  |                  | 061028 |        |  |  |  |  |        |            | 8          |
| 778741  |                  | 061032 |        |  |  |  |  |        |            | 8          |
| 778772  |                  | 012111 |        |  |  |  |  |        |            | 3          |
| 778774  |                  | 011027 | 933315 |  |  |  |  | 992302 | 111        | 5          |
| 778797  |                  | 012032 |        |  |  |  |  |        |            | 2          |
| 778863  |                  | 012056 | 933013 |  |  |  |  | 992505 | 118        | 4          |
| 5005384 |                  | 062103 |        |  |  |  |  |        |            | 2          |
| 5005385 |                  | 062104 |        |  |  |  |  |        |            | 2          |
| 5031619 |                  | 032042 | 993213 |  |  |  |  | 992406 | 993406     | 115        |
| 5031627 |                  | 032040 | 933215 |  |  |  |  | 992408 | 993408     | 115        |
| 5031628 |                  |        |        |  |  |  |  | 992409 |            | 115        |
| 5032107 |                  |        |        |  |  |  |  | 992502 |            | 121        |
| 5032108 |                  |        |        |  |  |  |  | 992503 |            | 121        |
| 5032109 |                  |        |        |  |  |  |  | 992504 |            | 121        |
| 5032110 |                  |        | 933013 |  |  |  |  | 992505 |            | 121        |
| 5032171 |                  |        |        |  |  |  |  | 992501 |            | 121        |
| 5033201 |                  | 062103 |        |  |  |  |  |        |            | 2          |
| 5033203 |                  | 062105 |        |  |  |  |  |        |            | 2          |
| 5033322 |                  | 061020 | 933415 |  |  |  |  | 992113 | 993143     | See Note 4 |
| 5033323 |                  | 061024 | 933417 |  |  |  |  | 992114 | 993144     | See Note 4 |
| 5033324 |                  | 061028 | 933419 |  |  |  |  | 992115 | 993145     | See Note 4 |
| 5033325 |                  | 061032 | 933421 |  |  |  |  | 992116 | 993146     | See Note 4 |
| 5033327 |                  | 061024 | 933417 |  |  |  |  | 992114 | 993144     | See Note 4 |
| 5033328 |                  | 061028 | 933419 |  |  |  |  | 992115 | 993145     | See Note 4 |
| 5033329 |                  | 061032 | 933421 |  |  |  |  | 992116 | 993146     | See Note 4 |
| 5040538 |                  | 142102 |        |  |  |  |  |        |            | 2          |
| 5040590 |                  | 142204 |        |  |  |  |  |        |            | 3          |
| 5040591 |                  | 142205 |        |  |  |  |  |        |            | 3          |
| 5040592 |                  | 142206 |        |  |  |  |  |        |            | 3          |

### FORCE®, CHRYSLER, U.S. MARINE

|             |            |        |        |        |  |  |  |        |        |     |    |
|-------------|------------|--------|--------|--------|--|--|--|--------|--------|-----|----|
| 48-16986A45 | Vengeance  | 031041 | 933415 |        |  |  |  | 992113 | 993143 | 202 | 15 |
| 48-16986A5  | QSS™       | 031041 | 933415 |        |  |  |  | 992113 | 993143 | 202 | 15 |
| 48-16988A40 | QSS™       | 031042 | 933417 |        |  |  |  | 992114 | 993144 | 202 | 15 |
| 48-16988A45 | Vengeance  | 031042 | 933417 |        |  |  |  | 992114 | 993144 | 202 | 15 |
| 48-16990A45 | Laser II™  | 031043 | 933419 |        |  |  |  | 992115 | 993145 | 202 | 15 |
| 48-16992A45 | Laser II™  | 031044 | 933421 | 953422 |  |  |  | 992116 | 993146 | 202 | 15 |
| 48-19636A10 |            |        |        |        |  |  |  | 992501 |        | 120 | 12 |
| 48-19638A40 | Black Max™ | 031049 |        |        |  |  |  | 992503 |        | 120 | 12 |
| 48-19639A40 | Black Max™ |        |        |        |  |  |  | 992504 |        | 120 | 12 |
| 48-19640A40 | Black Max™ | 031048 | 933013 |        |  |  |  | 992505 |        | 120 | 12 |

\* Indicates limited quantities.

# MICHIGAN WHEEL OEM CROSS REFERENCE

| Original Equipment Manufacturer<br>Part & Trade Mark | Standard<br>Hub<br>Propeller | XHS® / XHS II® Hub Propeller |                  |                |                 |                    | XHS® / XHS II®<br>Hub Kit(s) | Catalog Page #s |
|--|------------------------------|------------------------------|------------------|----------------|-----------------|--------------------|------------------------------|-----------------|
|  | Michigan<br>Match®           | Ballistic®                   | Ballistic®<br>XL | Vortex®<br>XHS | Apollo®<br>Std. | Apollo®<br>Lg. Dia |                              |                 |

## FORCE®, CHRYSLER, U.S. MARINE (Continued)

|              |            |         |        |        |  |  |               |     |    |
|--------------|------------|---------|--------|--------|--|--|---------------|-----|----|
| 48-19642A40  | Black Max™ |         |        |        |  |  | 992506        | 120 | 12 |
| 48-42738A10  | Black Max™ | 032141  |        |        |  |  |               |     | 13 |
| 48-42740A10  | Black Max™ | 032142  |        |        |  |  |               |     | 13 |
| 48-64724A4   |            | 031020  |        |        |  |  |               |     | 13 |
| 48-73132A40  | Black Max™ | 031015  |        |        |  |  |               |     | 13 |
| 48-73134A4   | Black Max™ | 031016  |        |        |  |  | 992405 993405 | 114 | 13 |
| 48-73134A40  | Black Max™ | 031016  |        |        |  |  | 992405 993405 | 114 | 13 |
| 48-73136A4   | Black Max™ | 031017  | 933213 |        |  |  | 992406 993406 | 114 | 13 |
| 48-73136A40  | Black Max™ | 031017  | 933213 |        |  |  | 992406 993406 | 114 | 13 |
| 48-73138A4   | Black Max™ | 031018  |        |        |  |  | 992407 993407 | 114 | 13 |
| 48-73138A40  | Black Max™ | 031018  |        |        |  |  | 992407 993407 | 114 | 13 |
| 48-73140A4   | Black Max™ | 031019  | 933215 |        |  |  | 992408 993408 | 114 | 13 |
| 48-73140A40  | Black Max™ | 031019  | 933215 |        |  |  | 992408 993408 | 114 | 13 |
| 48-73142A40  | Black Max™ |         |        |        |  |  | 992409        | 114 | 13 |
| 48-73144A40  | Black Max™ | 031020  |        |        |  |  |               |     | 13 |
| 48-76228A4   | QSS™       | 031017  | 933213 |        |  |  | 992406 993406 | 114 | 13 |
| 48-76228A5   | Vengeance  | 031017  | 933213 |        |  |  | 992406 993406 | 114 | 13 |
| 48-76230A4   | QSS™       | 031018  |        |        |  |  | 992407 993407 | 114 | 13 |
| 48-76230A5   | Vengeance  | 031018  |        |        |  |  | 992407 993407 | 114 | 13 |
| 48-76232A4   | QSS™       | 031019  | 933215 |        |  |  | 992408 993408 | 114 | 13 |
| 48-76232A5   | Vengeance  | 031019  | 933215 |        |  |  | 992409 993408 | 114 | 13 |
| 48-77338A45  | Black Max™ | 031254  |        |        |  |  |               |     | 15 |
| 48-77338CP1  | Pontoon    |         |        |        |  |  | 941411        | 202 | 15 |
| 48-77340A40  | Black Max™ | 031055  |        |        |  |  | 992112        | 202 | 15 |
| 48-77340A45  | Black Max™ | 031055  |        |        |  |  | 992112        | 202 | 15 |
| 48-77338CP1  | Pontoon    |         |        |        |  |  | 941413        | 202 | 15 |
| 48-77342A40  | Black Max™ | 031041  | 933415 |        |  |  | 992113 993143 | 202 | 15 |
| 48-77342A45  | Black Max™ | 031041  | 933415 |        |  |  | 992113 993143 | 202 | 15 |
| 48-77344A40  | Black Max™ | 031042  | 933417 |        |  |  | 992114 993144 | 202 | 15 |
| 48-77344A45  | Black Max™ | 031042  | 933417 |        |  |  | 992114 993144 | 202 | 15 |
| 48-77346A40  | Black Max™ | 031043  | 933419 |        |  |  | 992115 993145 | 202 | 15 |
| 48-77346A45  | Black Max™ | 031043  | 933419 |        |  |  | 992115 993145 | 202 | 15 |
| 48-77348A40  | Black Max™ | 031044  | 933421 | 953422 |  |  | 992116 993146 | 202 | 15 |
| 48-77348A45  | Black Max™ | 031044  | 933421 | 953422 |  |  | 992116 993146 | 202 | 15 |
| 48-77350A40  | Black Max™ | 031045* |        |        |  |  |               |     | 15 |
| 48-77350A45  | Black Max™ | 031045* |        |        |  |  |               |     | 15 |
| 48-79792A4   | QSS™       | 031016  |        |        |  |  | 992405 993405 | 114 | 13 |
| 48-79792A5   | Vengeance  | 031016  |        |        |  |  | 992405 993405 | 114 | 13 |
| 48-816702A40 |            | 031056  |        |        |  |  | 992405 993405 | 114 | 13 |
| 48-816704A40 |            | 031057  |        |        |  |  | 992406 993406 | 114 | 13 |
| 48-816706A40 |            | 031058  | 933213 |        |  |  | 992407 993407 | 114 | 13 |
| 48-819334A40 |            | 072133  |        |        |  |  |               |     | 13 |
| 48-819335A40 |            | 072132  |        |        |  |  |               |     | 13 |
| 48-819336A40 |            | 072131  |        |        |  |  |               |     | 13 |
| 48-819337A40 |            | 072014  |        |        |  |  |               |     | 13 |
| 48-819337A45 |            | 072014  |        |        |  |  |               |     | 13 |
| 48-855858A5  | Vengeance  | 031057  |        |        |  |  | 992406 993406 | 114 | 13 |
| 48-85632A40  | Black Max™ | 031053  |        |        |  |  | 992404        | 114 | 13 |
| 48-FP488     |            | 072123  |        |        |  |  |               |     | 12 |
| 48-FP669-1   |            | 071035  |        |        |  |  | 992113 993143 | 202 | 14 |
| 48-FP669-2   |            | 071035  |        |        |  |  | 992113 993143 | 202 | 14 |
| 48-FP669-3   |            | 071035  |        |        |  |  | 992113 993143 | 202 | 14 |
| 48-FP685-1   |            | 071036  |        |        |  |  | 992114 993144 | 202 | 14 |
| 48-FP685-2   |            | 071036  |        |        |  |  | 992114 993144 | 202 | 14 |
| 48-FP685-3   |            | 071036  |        |        |  |  | 992114 993144 | 202 | 14 |
| 48-FP686-1   |            |         |        |        |  |  | 992115 993145 | 202 | 14 |
| 48-FP686-3   |            |         |        |        |  |  | 992115 993145 | 202 | 14 |
| 48-FP686-4   |            |         |        |        |  |  | 992115 993145 | 202 | 14 |
| 48-FP692-1   |            | 072127  |        |        |  |  | 992113 993143 | 202 | 14 |
| 48-FP692-2   |            | 072127  |        |        |  |  | 992113 993143 | 202 | 14 |
| 48-FP692-3   |            | 072127  |        |        |  |  | 992113 993143 | 202 | 14 |
| 48-FP694     |            |         |        |        |  |  | 992116 993146 | 202 | 14 |
| FA282265     |            | 072132  |        |        |  |  |               |     | 13 |
| FA287265     |            | 072131  |        |        |  |  |               |     | 13 |
| FA378265     |            | 072132  |        |        |  |  |               |     | 13 |
| FP273        |            | 072133  |        |        |  |  |               |     | 13 |
| FP274        |            | 072014  |        |        |  |  |               |     | 13 |
| FP276        |            | 072014  |        |        |  |  |               |     | 13 |
| FP277        |            | 072131  |        |        |  |  |               |     | 13 |
| FP278        |            | 072014  |        |        |  |  |               |     | 13 |
| FP282        |            | 072132  |        |        |  |  |               |     | 13 |
| FP287        |            | 072131  |        |        |  |  |               |     | 13 |
| FP293        |            | 072132  |        |        |  |  |               |     | 13 |

# MICHIGAN WHEEL OEM CROSS REFERENCE

| Original Equipment Manufacturer<br>Part & Trade Mark | Standard<br>Hub<br>Propeller | XHS® / XHS II® Hub Propeller |                  |                |                 |                    |                    | XHS® / XHS II®<br>Hub Kit(s) | Catalog Page #s |
|--|------------------------------|------------------------------|------------------|----------------|-----------------|--------------------|--------------------|------------------------------|-----------------|
|  | Michigan<br>Match®           | Ballistic®                   | Ballistic®<br>XL | Vortex®<br>XHS | Apollo®<br>Std. | Apollo®<br>Lg. Dia | Apollo®<br>4-Blade |                              |                 |

## FORCE®, CHRYSLER, U.S. MARINE (Continued)

|         |        |        |  |        |        |  |     |  |    |
|---------|--------|--------|--|--------|--------|--|-----|--|----|
| FP328   | 072014 |        |  |        |        |  |     |  | 13 |
| FP366   | 072014 |        |  |        |        |  |     |  | 13 |
| FP378   | 072132 |        |  |        |        |  |     |  | 13 |
| FP519   | 072055 |        |  |        |        |  |     |  | 14 |
| FPS23   | 072107 |        |  |        |        |  |     |  | 14 |
| FPS24   | 072108 |        |  |        |        |  |     |  | 14 |
| FP623   | 072107 |        |  |        |        |  |     |  | 14 |
| FP654   | 072108 |        |  |        |        |  |     |  | 14 |
| FP665   | 071035 |        |  |        |        |  |     |  | 14 |
| FP669   | 071035 |        |  |        |        |  |     |  | 14 |
| FP669-1 | 071035 |        |  |        |        |  |     |  | 14 |
| FP682   | 072127 |        |  |        |        |  |     |  | 14 |
| FP685-1 | 072128 |        |  |        |        |  |     |  | 14 |
| FP692   | 072127 |        |  |        |        |  |     |  | 14 |
| FP692-1 | 072127 |        |  |        |        |  |     |  | 14 |
| FPM736  | 031020 |        |  |        |        |  |     |  | 13 |
| FPM738  | 031019 |        |  | 992408 | 993408 |  | 114 |  | 13 |
| FPM752  | 031058 | 933213 |  | 992407 | 993407 |  | 114 |  | 13 |
| FPM754  | 031056 |        |  | 992405 | 993405 |  | 114 |  | 13 |
| FPM756  | 031015 |        |  |        |        |  |     |  | 13 |
| FPS523  | 072107 |        |  |        |        |  |     |  | 14 |
| FPS524  | 072108 |        |  |        |        |  |     |  | 14 |
| FPS623  | 072107 |        |  |        |        |  |     |  | 14 |
| FPS625  | 072108 |        |  |        |        |  |     |  | 14 |
| FPS626  | 072109 |        |  |        |        |  |     |  | 14 |
| FPS654  | 072108 |        |  |        |        |  |     |  | 14 |

## HONDA®

|                 |                    |        |        |        |        |  |            |  |    |
|-----------------|--------------------|--------|--------|--------|--------|--|------------|--|----|
| 08M60-ZW7-A10   | Turbo 3-Blade      | 031042 | 933417 | 992114 | 993144 |  | See Note 3 |  | 18 |
| 08M60-ZW7-A20   | Turbo 3-Blade      | 031043 | 933419 | 992115 | 993145 |  | See Note 3 |  | 18 |
| 08M60-ZW7-A30   | Turbo 3-Blade      | 031044 | 933421 | 992116 | 993146 |  | See Note 3 |  | 18 |
| 08M60-ZW7-B00   | Turbo 3-Blade (LH) |        |        |        | 993153 |  | See Note 3 |  | 18 |
| 08M60-ZW7-B10   | Turbo 3-Blade (LH) |        |        |        | 993154 |  | See Note 3 |  | 18 |
| 08M60-ZW7-B20   | Turbo 3-Blade (LH) |        |        |        | 993155 |  | See Note 3 |  | 18 |
| 08M60-ZW7-B30   | Turbo 3-Blade (LH) |        |        |        | 993156 |  | See Note 3 |  | 18 |
| 58110-ZV4-300   |                    | 102005 |        |        |        |  |            |  | 16 |
| 58110-ZV5-E00   | Turbo 3-Blade      | 032040 | 933215 | 992408 | 993408 |  | 113        |  | 17 |
| 58110-ZV5-E10   | Turbo 3-Blade      | 032041 |        | 992606 | 993407 |  | 113        |  | 17 |
| 58110-ZV5-E20   | Turbo 3-Blade      | 032042 | 993213 | 992605 | 993406 |  | 113        |  | 17 |
| 58110-ZV5-E30   | Turbo 3-Blade      | 032043 |        | 992405 | 993405 |  | 113        |  | 17 |
| 58130-881-840ZA |                    | 012109 |        |        |        |  |            |  | 16 |
| 58130-881-840ZB |                    | 012109 |        |        |        |  |            |  | 16 |
| 58130-935-000N  |                    | 012109 |        |        |        |  |            |  | 16 |
| 58130-935-600N  |                    | 012109 |        |        |        |  |            |  | 16 |
| 58130-ZV4-000ZA |                    | 102005 |        |        |        |  |            |  | 16 |
| 58130-ZV4-008AH | Solas® Honda       | 102003 |        |        |        |  |            |  | 16 |
| 58130-ZV4-009AH | Solas® Honda       | 102004 |        |        |        |  |            |  | 16 |
| 58130-ZV4-010ZA | Solas® Honda       | 102005 |        |        |        |  |            |  | 16 |
| 58130-ZV4-020ZA |                    | 102005 |        |        |        |  |            |  | 16 |
| 58130-ZV4-030ZA |                    | 102005 |        |        |        |  |            |  | 16 |
| 58130-ZV4-030ZB |                    | 102005 |        |        |        |  |            |  | 16 |
| 58130-ZV4-700ZA |                    | 102004 |        |        |        |  |            |  | 16 |
| 58130-ZV4-701ZA |                    | 102004 |        |        |        |  |            |  | 16 |
| 58130-ZV4-702ZA |                    | 102004 |        |        |        |  |            |  | 16 |
| 58130-ZV4-703ZA |                    | 102004 |        |        |        |  |            |  | 16 |
| 58130-ZV4-703ZB |                    | 102004 |        |        |        |  |            |  | 16 |
| 58130-ZV5-000ZA |                    | 032042 | 993213 | 992605 | 993406 |  | 113        |  | 17 |
| 58130-ZV5-011AH | Solas® Honda       | 032044 |        | 992603 | 993404 |  | 113        |  | 17 |
| 58130-ZV5-012AH | Solas® Honda       | 032043 |        | 992604 | 993405 |  | 113        |  | 17 |
| 58130-ZV5-013AH | Solas® Honda       | 032042 |        | 992605 | 993406 |  | 113        |  | 17 |
| 58130-ZV5-014AH | Solas® Honda       | 032041 |        | 992606 | 993407 |  | 113        |  | 17 |
| 58130-ZV5-015AH | Solas® Honda       | 032040 |        | 992408 | 993408 |  | 113        |  | 17 |
| 58130-ZV5-850ZA |                    | 032043 |        | 992604 | 993405 |  | 113        |  | 17 |
| 58130-ZV5-860ZA |                    | 032045 |        | 992603 |        |  | 113        |  | 17 |
| 58130-ZV5-870ZA |                    | 032040 | 933215 | 992408 | 993408 |  | 113        |  | 17 |
| 58130-ZV7-009AH | Solas® Honda       |        |        | 992501 |        |  | 119        |  | 16 |
| 58130-ZV7-010AH | Solas® Honda       |        |        | 992502 |        |  | 119        |  | 16 |
| 58130-ZV7-011AH | Solas® Honda       |        |        | 992503 |        |  | 119        |  | 16 |
| 58130-ZV7-012AH | Solas® Honda       |        |        | 992504 |        |  | 119        |  | 16 |
| 58130-ZV7-013AH | Solas® Honda       |        | 933013 | 992505 |        |  | 119        |  | 16 |
| 58130-ZW1-011AH | Solas® Honda       | 031254 |        | 992111 |        |  | See Note 3 |  | 18 |
| 58130-ZW1-013AH | Solas® Honda       | 031055 |        | 992112 |        |  | See Note 3 |  | 18 |
| 58130-ZW1-015AH | Solas® Honda       | 031041 | 933415 | 992113 | 993143 |  | See Note 3 |  | 18 |

\* Indicates limited quantities.

# MICHIGAN WHEEL OEM CROSS REFERENCE

| Original Equipment Manufacturer<br>Part & Trade Mark | Standard<br>Hub<br>Propeller | XHS® / XHS II® Hub Propeller |                  |                |                 |                    |                    | XHS® / XHS II®<br>Hub Kit(s) | Catalog Page #s |
|--|------------------------------|------------------------------|------------------|----------------|-----------------|--------------------|--------------------|------------------------------|-----------------|
|  | Michigan<br>Match®           | Ballistic®                   | Ballistic®<br>XL | Vortex®<br>XHS | Apollo®<br>Std. | Apollo®<br>Lg. Dia | Apollo®<br>4-Blade |                              |                 |

## HONDA® (Continued)

|                 |                       |         |        |        |        |        |        |            |     |
|-----------------|-----------------------|---------|--------|--------|--------|--------|--------|------------|-----|
| 58130-ZW1-015B  | Solas® Honda (LH)     |         |        |        |        |        | 993153 | See Note 3 | 18  |
| 58130-ZW1-017AH | Solas® Honda          | 031042  | 933417 |        | 992114 | 993144 |        | See Note 3 | 18  |
| 58130-ZW1-017B  | Solas® Honda (LH)     |         |        |        |        |        | 993154 | See Note 3 | 18  |
| 58130-ZW1-019AH | Solas® Honda          | 031043  | 933419 |        | 992115 | 993145 |        | See Note 3 | 18  |
| 58130-ZW1-021AH | Solas® Honda          | 031044  | 933421 | 953422 | 992116 | 993146 |        | See Note 3 | 18  |
| 58130-ZW1-V01   |                       | 031042  | 933417 |        | 992114 | 993144 |        | See Note 3 | 18  |
| 58130-ZW1-V11   |                       | 031043  | 933419 |        | 992115 | 993145 |        | See Note 3 | 18  |
| 58130-ZW1-V31   |                       | 031044  | 933421 | 953422 | 992116 | 993146 |        | See Note 3 | 18  |
| 58130-ZW1-W01ZA |                       | 031254  |        |        | 992111 |        |        | See Note 3 | 18  |
| 58130-ZW1-W11ZA |                       | 031055  |        |        | 992112 |        |        | See Note 3 | 18  |
| 58130-ZW1-W21ZA |                       | 031041  | 933415 |        | 992113 | 993143 |        | See Note 3 | 18  |
| 58130-ZW1-W31ZA |                       | 031042  | 933417 |        | 992114 | 993144 |        | See Note 3 | 18  |
| 58130-ZW1-W41ZA |                       | 031044  | 933421 | 953422 | 992116 | 993146 |        | See Note 3 | 18  |
| 58130-ZW1-W51ZA |                       | 031045* |        |        |        |        |        |            | 18  |
| 58130-ZW1-W61ZA |                       | 031043  | 933419 |        | 992115 | 993145 |        | See Note 3 | 18  |
| 58130-ZW1-W91   |                       | 031041  | 933415 |        | 992113 | 993143 |        | See Note 3 | 18  |
| 58130-ZW2-F01ZA |                       | 111106  |        |        |        |        |        |            | 16  |
| 58130-ZW2-F11AZ |                       | 111103  |        |        |        |        |        |            | 16  |
| 58130-ZW2-F21AZ |                       | 111107  |        |        |        |        |        |            | 16  |
| 58130-ZW2-F31AZ |                       | 111105  |        |        |        |        |        |            | 16  |
| 58130-ZW2-F41AZ |                       | 111108  |        |        |        |        |        |            | 16  |
| 58130-ZY3-013A  | Solas® Honda          | 031513  |        |        | 992001 |        |        | 207        | 19  |
| 58130-ZY3-015A  | Solas® Honda          | 031023  | 933515 |        | 992002 | 993042 | 993022 | 207        | 19  |
| 58130-ZY3-017A  | Solas® Honda          | 031024  | 933517 |        | 992003 | 993043 | 993023 | 993203     | 207 |
| 58130-ZY3-017AP | Solas® Honda          | 031064  | 933517 |        | 992003 | 993043 | 993023 | 993203     | 207 |
| 58130-ZY3-017B  | Solas® Honda (LH)     |         | 937517 |        |        | 993053 | 993033 | 993213     | 207 |
| 58130-ZY3-017BP | Solas® Honda (LH)     |         | 937517 |        |        | 993053 | 993033 | 993213     | 207 |
| 58130-ZY3-017P  | Solas® Honda          | 031064  | 933517 |        | 992003 | 993043 | 993023 | 993203     | 207 |
| 58130-ZY3-019A  | Solas® Honda          | 031025  | 933519 |        | 992004 | 993044 | 993024 | 993204     | 207 |
| 58130-ZY3-019AP | Solas® Honda          | 031065  | 933519 |        | 992004 | 993044 | 993024 | 993204     | 207 |
| 58130-ZY3-019B  | Solas® Honda (LH)     |         | 937519 |        |        | 993054 | 993034 | 993214     | 207 |
| 58130-ZY3-021A  | Solas® Honda          | 031026  | 933521 |        | 992005 | 993045 | 993025 | 993205     | 207 |
| 58130-ZY3-021B  | Solas® Honda (LH)     |         | 937521 |        |        | 993055 | 993035 | 993215     | 207 |
| 58130-ZY3-023A  | Solas® Honda          |         | 933523 |        | 992006 | 993046 | 993026 | 993206     | 207 |
| 58130-ZY3-15B   | Solas® Honda          |         |        |        |        | 993052 |        | 207        | 19  |
| 58133-ZV4-008AH | Solas® Saturn         | 102003  |        |        |        |        |        |            | 16  |
| 58133-ZV4-009AH | Solas® Saturn         | 102004  |        |        |        |        |        |            | 16  |
| 58133-ZV4-010AH | Solas® Saturn         | 102005  |        |        |        |        |        |            | 16  |
| 58133-ZV5-012AH | Solas® Saturn         | 032043  |        |        | 992604 | 993405 |        | 113        | 17  |
| 58133-ZV5-013AH | Solas® Saturn         | 032042  | 993213 |        | 992605 | 993406 |        | 113        | 17  |
| 58133-ZV5-014AH | Solas® Saturn         | 032041  |        |        | 992606 | 993407 |        | 113        | 17  |
| 58133-ZV5-015AH | Solas® Saturn         | 032040  | 933215 |        | 992408 | 993408 |        | 113        | 17  |
| 58133-ZV7-013AH | Solas® Saturn         |         | 933013 |        | 992505 |        |        | 119        | 16  |
| 58133-ZW1-A11P  | Solas® New Saturn     |         |        |        | 941411 |        |        | See Note 3 | 18  |
| 58133-ZW1-A13P  | Solas® New Saturn     |         |        |        | 941413 |        |        | See Note 3 | 18  |
| 58133-ZW1-A15AH | Solas® Titan          | 031041  | 933415 |        | 992113 | 993143 |        | See Note 3 | 18  |
| 58133-ZW1-A15HR | Solas® Titan HR3      | 031041  | 933415 |        | 992113 | 993143 |        | See Note 3 | 18  |
| 58133-ZW1-A17AH | Solas® Titan          | 031042  | 933417 |        | 992114 | 993144 |        | See Note 3 | 18  |
| 58133-ZW1-A17HR | Solas® Titan HR3      | 031042  | 933417 |        | 992114 | 993144 |        | See Note 3 | 18  |
| 58133-ZW1-A19AH | Solas® Titan          | 031043  | 933419 |        | 992115 | 993145 |        | See Note 3 | 18  |
| 58133-ZW1-A19HR | Solas® Titan HR3      | 031043  | 933419 |        | 992115 | 993145 |        | See Note 3 | 18  |
| 58133-ZW1-A21HR | Solas® Titan HR3      | 031044  | 933421 |        | 992116 | 993146 |        | See Note 3 | 18  |
| 58133-ZW1-B15AH | Solas® Titan (LH)     |         |        |        |        | 993153 |        | See Note 3 | 18  |
| 58133-ZW1-B17AH | Solas® Titan (LH)     |         |        |        |        | 993154 |        | See Note 3 | 18  |
| 58133-ZW1-B17HR | Solas® Titan HR3 (LH) |         |        |        |        | 993154 |        | See Note 3 | 18  |
| 58133-ZW1-B19AH | Solas® Titan (LH)     |         |        |        |        | 993155 |        | See Note 3 | 18  |
| 58133-ZW1-B19HR | Solas® Titan HR3 (LH) |         |        |        |        | 993155 |        | See Note 3 | 18  |
| 58133-ZW1-B21HR | Solas® Titan HR3 (LH) |         |        |        |        | 993156 |        | See Note 3 | 18  |
| 58133-ZY3-A15AH | Solas® New Saturn     | 031023  | 933515 |        | 992002 | 993042 |        | 207        | 19  |
| 58133-ZY3-A15LX | Solas® Lexor          | 031024  | 933517 |        | 992003 | 993043 | 993023 | 993203     | 207 |
| 58133-ZY3-A15S  | Solas® Titan          | 031023  | 933515 |        | 992002 | 993042 |        | 207        | 19  |
| 58133-ZY3-A17AH | Solas® Titan          | 031024  | 933517 |        | 992003 | 993043 | 993023 | 993203     | 207 |
| 58133-ZY3-A17HR | Solas® Titan HR3      | 031024  | 933517 |        | 992003 | 993043 | 993023 | 993203     | 207 |
| 58133-ZY3-A17LX | Solas® Lexor          | 031065  | 933519 |        | 992004 | 993044 | 993024 | 993204     | 207 |
| 58133-ZY3-A17S  | Solas® Titan          | 031024  | 933517 |        | 992003 | 993043 | 993023 | 993203     | 207 |
| 58133-ZY3-A19AH | Solas® Titan          | 031065  | 933519 |        | 992004 | 993044 | 993024 | 993204     | 207 |
| 58133-ZY3-A19HR | Solas® Titan HR3      | 031065  | 933519 |        | 992004 | 993044 | 993024 | 993204     | 207 |
| 58133-ZY3-A19LX | Solas® Lexor          | 031026  | 933521 |        | 992005 | 993045 | 993025 | 993205     | 207 |
| 58133-ZY3-A19S  | Solas® Titan          | 031065  | 933519 |        | 992004 | 993044 | 993024 | 993204     | 207 |
| 58133-ZY3-A21AH | Solas® Titan          | 031026  | 933521 |        | 992005 | 993045 | 993025 | 993205     | 207 |
| 58133-ZY3-A21HR | Solas® Titan HR       | 031026  | 933521 |        | 992005 | 993045 | 993025 | 993205     | 207 |
| 58133-ZY3-A21LX | Solas® Lexor          |         | 933523 |        | 992006 | 993046 | 993026 | 993206     | 207 |
| 58133-ZY3-A21S  | Solas® Titan          | 031026  | 933521 |        | 992005 | 993045 | 993025 | 993205     | 207 |

\* Indicates limited quantities.

# MICHIGAN WHEEL OEM CROSS REFERENCE

| Original Equipment Manufacturer<br>Part & Trade Mark | Standard<br>Hub<br>Propeller | XHS® / XHS II® Hub Propeller |                  |                |                 |                    |                    | XHS® / XHS II®<br>Hub Kit(s) | Catalog Page #s |
|--|------------------------------|------------------------------|------------------|----------------|-----------------|--------------------|--------------------|------------------------------|-----------------|
|  | Michigan<br>Match®           | Ballistic®                   | Ballistic®<br>XL | Vortex®<br>XHS | Apollo®<br>Std. | Apollo®<br>Lg. Dia | Apollo®<br>4-Blade |                              |                 |

### HONDA® (Continued)

|                 |                        |        |        |  |        |        |        |        |            |     |    |
|-----------------|------------------------|--------|--------|--|--------|--------|--------|--------|------------|-----|----|
| 58133-ZY3-A23S  | Solas® Titan           | 933523 |        |  | 992006 | 993046 | 993026 | 993206 | 207        | 19  |    |
| 58133-ZY3-A25AH |                        | 933525 |        |  |        |        |        |        | 207        | 19  |    |
| 58133-ZY3-B15AH | Solas® New Saturn (LH) |        |        |  |        | 993052 |        |        | 207        | 19  |    |
| 58133-ZY3-B15LX | Solas® Lexor (LH)      | 937517 |        |  |        | 993053 | 993033 | 993213 | 207        | 19  |    |
| 58133-ZY3-B17AH | Solas® New Saturn (LH) | 937517 |        |  |        | 993053 | 993033 | 993213 | 207        | 19  |    |
| 58133-ZY3-B17HR | Solas® Titan HR3 (LH)  | 937517 |        |  |        | 993053 | 993033 | 993213 | 207        | 19  |    |
| 58133-ZY3-B17S  | Solas® Titan (LH)      | 937517 |        |  |        | 993053 | 993033 | 993213 | 207        | 19  |    |
| 58133-ZY3-B19AH | Solas® New Saturn (LH) | 937519 |        |  |        | 993054 | 993034 | 993214 | 207        | 19  |    |
| 58133-ZY3-B19HR | Solas® Titan HR3 (LH)  | 937519 |        |  |        | 993054 | 993034 | 993214 | 207        | 19  |    |
| 58133-ZY3-B19LX | Solas® Lexor (LH)      | 937521 |        |  |        | 993055 | 993035 | 993215 | 207        | 19  |    |
| 58133-ZY3-B19S  | Solas® Titan (LH)      | 937519 |        |  |        | 993054 | 993034 | 993214 | 207        | 19  |    |
| 58133-ZY3-B21AH | Solas® New Saturn (LH) | 937521 |        |  |        | 993055 | 993035 | 993215 | 207        | 19  |    |
| 58133-ZY3-B21HR | Solas® Titan HR3 (LH)  | 937521 |        |  |        | 993055 | 993035 | 993215 | 207        | 19  |    |
| 58133-ZY3-B21LX | Solas® Lexor (LH)      | 937523 |        |  |        | 993056 | 993036 | 993216 | 207        | 19  |    |
| 58133-ZY3-B21S  | Solas® Titan (LH)      | 937521 |        |  |        | 993055 | 993035 | 993215 | 207        | 19  |    |
| 58133-ZY3-B23S  | Solas® Titan (LH)      | 937523 |        |  |        | 993056 | 993036 | 993216 | 207        | 19  |    |
| 58134-ZV5-009AH |                        |        |        |  | 992402 |        |        |        | 113        | 17  |    |
| 58134-ZV5-010AH |                        |        |        |  | 992403 |        |        |        | 113        | 17  |    |
| 58134-ZW1-013AH | Solas® Honda           |        |        |  | 941413 |        |        |        | See Note 3 | 18  |    |
| 58134-ZW1-015AH | Solas® Honda           |        |        |  | 941415 |        |        |        | See Note 3 | 18  |    |
| 58134-ZW1-017AH | Solas® Honda           |        |        |  | 941417 |        |        |        | See Note 3 | 18  |    |
| 58134-ZW1-019AH | Solas® Honda           |        |        |  | 941419 |        |        |        | See Note 3 | 18  |    |
| 58134-ZY3-017A  | Solas® Honda           |        |        |  | 992202 |        |        | 993203 | 207        | 19  |    |
| 58134-ZY3-017B  | Solas® Honda (LH)      |        |        |  |        |        |        | 993213 | 207        | 19  |    |
| 58134-ZY3-019A  | Solas® Honda           |        |        |  | 992203 |        |        | 993204 | 207        | 19  |    |
| 58134-ZY3-019B  | Solas® Honda (LH)      |        |        |  |        |        |        | 993214 | 207        | 19  |    |
| 58134-ZY3-021A  | Solas® Honda           |        |        |  | 992204 |        |        | 993205 | 207        | 19  |    |
| 58134-ZY3-021B  | Solas® Honda (LH)      |        |        |  |        |        |        | 993215 | 207        | 19  |    |
| 58134-ZY3-A18HR | Solas® Titan HR4       |        |        |  |        |        |        | 993204 | 207        | 19  |    |
| 58134-ZY3-A20HR | Solas® Titan HR4       |        |        |  |        |        |        | 993205 | 207        | 19  |    |
| 58134-ZY3-A21HR | Solas® Titan HR4       |        |        |  |        |        |        | 993205 | 207        | 19  |    |
| 58134-ZY3-B18HR | Solas® Titan HR4 (LH)  |        |        |  |        |        |        | 993214 | 207        | 19  |    |
| 58134-ZY3-B20HR | Solas® Titan HR4 (LH)  |        |        |  |        |        |        | 993215 | 207        | 19  |    |
| 58134-ZY3-B21HR | Solas® Titan HR4 (LH)  |        |        |  |        |        |        | 993215 | 207        | 19  |    |
| 58233-ZY3-A15H  | Turbo 3-Blade          | 031023 | 933515 |  | 992002 | 993042 |        |        | 207        | 19  |    |
| 58233-ZY3-A17H  | Turbo 3-Blade          | 031024 | 933517 |  | 992003 | 993043 | 993023 | 993203 | 207        | 19  |    |
| 58233-ZY3-A19H  | Turbo 3-Blade          | 031025 | 933519 |  | 992004 | 993044 | 993024 | 993204 | 207        | 19  |    |
| 58233-ZY3-A21H  | Turbo 3-Blade          | 031026 | 933521 |  | 992005 | 993045 | 993025 | 993205 | 207        | 19  |    |
| 58233-ZY3-A23H  | Turbo 3-Blade          | 031027 | 933523 |  | 992006 | 993046 | 993026 | 993206 | 207        | 19  |    |
| 58233-ZY3-A23HP | Turbo Performance      | 031027 | 933523 |  | 992006 | 993046 | 993026 | 993206 | 207        | 19  |    |
| 58233-ZY3-A25H  | Turbo 3-Blade          |        | 933525 |  |        |        |        |        | 207        | 19  |    |
| 58233-ZY3-B15H  | Turbo 3-Blade (LH)     |        |        |  |        | 993052 |        |        | 207        | 19  |    |
| 58233-ZY3-B17H  | Turbo 3-Blade (LH)     |        | 937517 |  |        | 993053 | 993033 | 993213 | 207        | 19  |    |
| 58233-ZY3-B19H  | Turbo 3-Blade (LH)     |        | 937519 |  |        | 993054 | 993034 | 993214 | 207        | 19  |    |
| 58233-ZY3-B21H  | Turbo 3-Blade (LH)     |        | 937521 |  |        | 993055 | 993035 | 993215 | 207        | 19  |    |
| 58233-ZY3-B23H  | Turbo 3-Blade (LH)     |        | 937523 |  |        | 993056 | 993036 | 993216 | 207        | 19  |    |
| 58234-ZY3-A20H  | Turbo 4-Blade          |        |        |  |        |        |        |        | 993205     | 207 | 19 |
| 58234-ZY3-A22H  | Turbo 4-Blade          |        | 963523 |  |        |        |        |        | 993206     | 207 | 19 |
| 58234-ZY3-A23HP | Turbo 4-Blade Perf.    |        | 963523 |  |        |        |        |        | 993206     | 207 | 19 |
| 58333-ZY3-A15CL | PowerTech OFS          |        | 933515 |  |        |        |        |        | 207        | 19  |    |
| 58333-ZY3-A17CL | PowerTech OFS          | 031024 | 933517 |  | 992003 | 993043 | 993023 | 993203 | 207        | 19  |    |
| 58333-ZY3-A19CL | PowerTech OFS          | 031025 | 933519 |  | 992004 | 993044 | 993024 | 993204 | 207        | 19  |    |
| 58333-ZY3-A21CL | PowerTech OFS          | 031026 | 933521 |  | 992005 | 993045 | 993025 | 993205 | 207        | 19  |    |
| 58333-ZY3-A23CL | PowerTech OFS          | 031027 | 933523 |  | 992006 | 993046 | 993026 | 993206 | 207        | 19  |    |
| 58333-ZY3-B17CL | PowerTech OFS (LH)     |        | 937517 |  |        | 993053 | 993033 | 993213 | 207        | 19  |    |
| 58333-ZY3-B19CL | PowerTech OFS (LH)     |        | 937519 |  |        | 993054 | 993034 | 993214 | 207        | 19  |    |
| 58333-ZY3-B21CL | PowerTech OFS (LH)     |        | 937521 |  |        | 993055 | 993035 | 993215 | 207        | 19  |    |
| 58333-ZY3-B23CL | PowerTech OFS (LH)     |        | 937523 |  |        | 993056 | 993036 | 993216 | 207        | 19  |    |

### MERCURY®, MARINER®, MERCUISER®

|             |              |        |        |        |        |        |        |        |     |       |
|-------------|--------------|--------|--------|--------|--------|--------|--------|--------|-----|-------|
| 48-11070A40 | Laser™       |        | 933521 | 953522 |        | 993045 | 993025 | 993205 | 202 | 26,47 |
| 48-11074A40 | Laser™       |        | 933523 | 953524 |        | 993046 | 993026 | 993206 | 202 | 26,47 |
| 48-11320A40 | Black Max™   | 031050 |        |        | 992002 | 993042 |        |        | 202 | 26,47 |
| 48-11322A40 | Black Max™   | 031516 |        |        | 992003 | 993043 | 993023 | 993203 | 202 | 26,47 |
| 48-11324A40 | Black Max™   | 031052 | 933519 |        | 992004 | 993044 | 993024 | 993204 | 202 | 26,47 |
| 48-11324A45 | Black Max™   | 031052 | 933519 |        | 992004 | 993044 | 993024 | 993204 | 202 | 26,47 |
| 48-1324A50  | Mirage®      | 031065 | 933519 |        | 992004 | 993044 | 993024 | 993204 | 202 | 26,47 |
| 48-1324A50  | Mirage® (LH) |        | 937521 |        |        | 993055 | 993035 | 993215 | 202 | 26,47 |
| 48-1324A50  | Mirage®      | 031066 | 933521 |        | 992005 | 993045 | 993025 | 993205 | 202 | 26,47 |
| 48-1324A50  | Mirage® (LH) |        | 937523 |        |        | 993056 | 993036 | 993216 | 202 | 26,47 |
| 48-13700A46 | Mirage® Plus |        |        |        |        |        | 993024 |        | 202 | 26,47 |
| 48-13701A40 | Mirage® (LH) |        | 937519 |        |        |        |        |        | 202 | 26,47 |
| 48-13701A41 | Mirage® (LH) |        | 937519 |        |        |        |        |        | 202 | 26,47 |

# MICHIGAN WHEEL OEM CROSS REFERENCE

| Original Equipment Manufacturer<br>Part & Trade Mark | Standard<br>Hub<br>Propeller | XHS® / XHS II® Hub Propeller |                  |                |                 |                    | XHS® / XHS II®<br>Hub Kit(s) | Catalog Page #s |
|--|------------------------------|------------------------------|------------------|----------------|-----------------|--------------------|------------------------------|-----------------|
|  | Michigan<br>Match®           | Ballistic®                   | Ballistic®<br>XL | Vortex®<br>XHS | Apollo®<br>Std. | Apollo®<br>Lg. Dia |                              |                 |

### MERCURY®, MARINER®, MERCURISER® (Continued)

|             |                   |        |        |  |        |        |        |        |       |       |
|-------------|-------------------|--------|--------|--|--------|--------|--------|--------|-------|-------|
| 48-13701A46 | Mirage® Plus (LH) |        | 937519 |  | 993054 | 993034 | 993214 | 202    | 26,47 |       |
| 48-13702A55 | Mirage® Plus      | 031066 | 933521 |  | 992005 | 993045 | 993025 | 993205 | 202   | 26,47 |
| 48-13703A55 | Mirage® Plus (LH) |        | 937521 |  |        | 993055 | 993035 | 993215 | 202   | 26,47 |
| 48-13704A46 | Mirage® Plus      |        | 933523 |  | 992006 | 993046 | 993026 | 993206 | 202   | 26,47 |
| 48-13705A55 | Mirage® Plus (LH) |        | 937523 |  |        |        |        | 202    | 26,47 |       |
| 48-13706A46 | Mirage® Plus      |        | 933525 |  |        |        |        | 202    | 26,47 |       |
| 48-16312A46 | Vengeance         | 031023 | 933515 |  | 992002 | 993042 |        | 202    | 26,47 |       |
| 48-16314A46 | Vengeance         | 031064 | 933517 |  | 992003 | 993043 | 993023 | 993203 | 202   | 26,47 |
| 48-16315A46 | Vengeance (LH)    |        | 937517 |  |        | 993053 | 993033 | 993213 | 202   | 26,47 |
| 48-16316A46 | Vengeance         | 031065 | 933519 |  | 992004 | 993044 | 993024 | 993204 | 202   | 26,47 |
| 48-16317A46 | Vengeance (LH)    |        | 937519 |  |        | 993054 | 993034 | 993214 | 202   | 26,47 |
| 48-16318A46 | Vengeance         | 031066 | 933521 |  | 992005 | 993045 | 993025 | 993205 | 202   | 26,47 |
| 48-16319A46 | Vengeance (LH)    |        | 937521 |  |        | 993055 | 993035 | 993215 | 202   | 26,47 |
| 48-16320A5  | QSS™              |        | 933523 |  | 992006 | 993046 | 993026 | 993206 | 202   | 26,47 |
| 48-16321A4  | QSS™              |        | 933523 |  | 992006 | 993046 | 993026 | 993206 | 202   | 26,47 |
| 48-16320A46 | Vengeance         |        | 933523 |  | 992006 | 993046 | 993026 | 993206 | 202   | 26,47 |
| 48-16320A5  | QSS™              |        | 933523 |  | 992006 | 993046 | 993026 | 993206 | 202   | 26,47 |
| 48-16321A46 | Vengeance (LH)    |        | 937523 |  |        | 993056 | 993036 | 993216 | 202   | 26,47 |
| 48-16322A4  | QSS™              |        | 933525 |  |        |        |        | 202    | 26,47 |       |
| 48-16322A46 | Vengeance         |        | 933525 |  |        |        |        | 202    | 26,47 |       |
| 48-16438A45 | Black Max™        | 031050 |        |  | 992002 | 993042 |        | 202    | 26,47 |       |
| 48-16440A45 | Black Max™        | 031516 |        |  | 992003 | 993043 | 993023 | 993203 | 202   | 26,47 |
| 48-16543A46 | Laser II™ (LH)    |        | 937519 |  |        | 993054 | 993034 | 993214 | 202   | 26,47 |
| 48-16544A46 | Laser II™         | 031065 | 933519 |  | 992004 | 993044 | 993024 | 993204 | 202   | 26,47 |
| 48-16545A46 | Laser II™ (LH)    |        | 937521 |  |        | 993055 | 993035 | 993215 | 202   | 26,47 |
| 48-16546A46 | Laser II™         | 031066 | 933521 |  | 992005 | 993045 | 993025 | 993205 | 202   | 26,47 |
| 48-16547A46 | Laser II™ (LH)    |        | 937523 |  |        | 993056 | 993036 | 993216 | 202   | 26,47 |
| 48-16548A41 | Laser II™         |        | 933523 |  | 992006 | 993046 | 993026 | 993206 | 202   | 26,47 |
| 48-16548A45 | Laser II™         |        | 933523 |  | 992006 | 993046 | 993026 | 993206 | 202   | 26,47 |
| 48-16548A46 | Laser II™         |        | 937523 |  |        | 993056 | 993036 | 993216 | 202   | 26,47 |
| 48-16550A40 | Laser II™         |        | 933525 |  |        |        |        | 202    | 26,47 |       |
| 45-16550A41 | Laser II™         |        | 933525 |  |        |        |        | 202    | 26,47 |       |
| 48-16550A45 | Laser II™         |        | 933525 |  |        |        |        | 202    | 26,47 |       |
| 48-16550A46 | Laser II™         |        | 933525 |  |        |        |        | 202    | 26,47 |       |
| 48-16986A46 | Vengeance         | 031041 | 933415 |  | 992113 | 993143 |        | 202    | 25    |       |
| 48-16988A46 | Vengeance         | 031042 | 933417 |  | 992114 | 993144 |        | 202    | 25    |       |
| 48-16990A45 | Laser II™         | 031043 | 933419 |  | 992115 | 993145 |        | 202    | 25    |       |
| 48-16992A40 | Laser II™         | 031044 | 933421 |  | 992116 | 993146 |        | 202    | 25    |       |
| 48-16994A46 | Laser II™         |        | 953424 |  |        |        |        | 202    | 25    |       |
| 48-17874A12 |                   | 032050 |        |  |        |        |        |        | 20    |       |
| 48-18278A46 | Mirage® Plus      |        | 933517 |  |        | 993043 | 993023 | 202    | 26,47 |       |
| 48-19636A10 | Black Max™        |        |        |  | 992501 |        |        | 120    | 21    |       |
| 48-19638A40 | Black Max™        | 031049 |        |  | 992503 |        |        | 120    | 21    |       |
| 48-19639A40 | Black Max™        |        |        |  | 992504 |        |        | 120    | 21    |       |
| 48-19640A40 | Black Max™        | 031048 | 933013 |  | 992505 |        |        | 120    | 21    |       |
| 48-19642A40 | Black Max™        |        | 933015 |  | 992506 |        |        | 120    | 21    |       |
| 48-19644A5  | Vengeance         |        | 933013 |  |        |        |        | 120    | 21    |       |
| 48-19841A46 | Mirage® Plus (LH) |        |        |  |        | 993052 | 993032 | 202    | 26,47 |       |
| 48-30388A1  |                   | 031042 | 933417 |  | 992114 | 993144 |        | 202    | 25    |       |
| 48-30390A1  |                   | 031041 | 933415 |  | 992113 | 993143 |        | 202    | 25    |       |
| 48-30396A1  |                   | 031254 |        |  | 992111 |        |        | 202    | 25    |       |
| 48-30396A3  |                   | 031254 |        |  | 992111 |        |        | 202    | 25    |       |
| 48-30396A4  |                   | 031254 |        |  | 992111 |        |        | 202    | 25    |       |
| 48-31072A4  |                   | 031041 | 933415 |  | 992113 | 993143 |        | 202    | 25    |       |
| 48-31080A1  |                   | 031042 | 933417 |  | 992114 | 993144 |        | 202    | 25    |       |
| 48-31082A1  |                   | 031041 | 933415 |  | 992113 | 993143 |        | 202    | 25    |       |
| 48-31454A3  |                   | 031043 | 933419 |  | 992115 | 993145 |        | 202    | 25    |       |
| 48-31456A3  |                   | 031042 | 933417 |  | 992114 | 993144 |        | 202    | 25    |       |
| 48-31458A3  |                   | 031041 | 933415 |  | 992113 | 993143 |        | 202    | 25    |       |
| 48-32264A3  |                   | 031041 | 933415 |  | 992113 | 993143 |        | 202    | 25    |       |
| 48-32386A3  |                   | 031043 | 933419 |  | 992115 | 993145 |        | 202    | 25    |       |
| 48-32386A4  |                   | 031048 |        |  |        |        |        |        | 21    |       |
| 48-32388A3  |                   | 031042 | 933417 |  | 992114 | 993144 |        | 202    | 25    |       |
| 48-32990A3  |                   | 031055 |        |  | 992112 |        |        | 202    | 25    |       |
| 48-32392A3  |                   | 031254 |        |  | 992111 |        |        | 202    | 25    |       |
| 48-32392A4  |                   | 031055 |        |  | 992112 |        |        | 202    | 25    |       |
| 48-32746A3  |                   | 031044 | 933421 |  | 992116 | 993146 |        | 202    | 25    |       |
| 48-32748A3  |                   | 031042 | 933417 |  | 992114 | 993144 |        | 202    | 25    |       |
| 48-32750A3  |                   | 031042 | 933417 |  | 992114 | 993144 |        | 202    | 25    |       |
| 48-33480A1  |                   | 032135 |        |  |        |        |        |        | 21    |       |
| 48-33482A1  |                   | 032136 |        |  |        |        |        |        | 21    |       |
| 48-35936A3  |                   | 031254 |        |  | 992111 |        |        | 202    | 25    |       |
| 48-35936A4  |                   | 031055 |        |  | 992112 |        |        | 202    | 25    |       |



# MICHIGAN WHEEL OEM CROSS REFERENCE

| Original Equipment Manufacturer<br>Part & Trade Mark | Standard<br>Hub<br>Propeller | XHS® / XHS II® Hub Propeller |                  |                |                 |                    |                    | XHS® / XHS II®<br>Hub Kit(s) | Catalog Page #s |
|--|------------------------------|------------------------------|------------------|----------------|-----------------|--------------------|--------------------|------------------------------|-----------------|
|  | Michigan<br>Match®           | Ballistic®                   | Ballistic®<br>XL | Vortex®<br>XHS | Apollo®<br>Std. | Apollo®<br>Lg. Dia | Apollo®<br>4-Blade |                              |                 |

### MERCURY®, MARINER®, MERCRUISER® (Continued)

|             |               |         |        |        |        |        |        |     |       |
|-------------|---------------|---------|--------|--------|--------|--------|--------|-----|-------|
| 48-36008A1  |               | 933523  |        | 992006 | 993046 | 993026 | 993206 | 202 | 26,47 |
| 48-36010A1  | 031026        | 933521  |        | 992005 | 993045 | 993025 | 993205 | 202 | 26,47 |
| 48-36010A4  |               | 933523  |        | 992006 | 993046 | 993026 | 993206 | 202 | 26,47 |
| 48-36012A1  | 031052        | 933519  |        | 992004 | 993044 | 993024 | 993204 | 202 | 26,47 |
| 48-36012A4  | 031026        | 933521  |        | 992005 | 993045 | 993025 | 993205 | 202 | 26,47 |
| 48-36012A5  | 031516        | 933515  |        | 992002 | 993043 | 993023 | 993203 | 202 | 26,47 |
| 48-36014A1  | 031516        | 933515  |        | 992002 | 993043 | 993023 | 993203 | 202 | 26,47 |
| 48-36014A4  | 032052        | 933519  |        | 992004 | 993044 | 993024 | 993204 | 202 | 26,47 |
| 48-36016A4  | 031516        | 933515  |        | 992002 | 993043 | 993023 | 993203 | 202 | 26,47 |
| 48-36018A1  | 031513        |         |        | 992001 |        |        |        | 202 | 26,47 |
| 48-36020A1  | 031513        |         |        | 992001 |        |        |        | 202 | 26,47 |
| 48-36020A4  | 031513        |         |        | 992001 |        |        |        | 202 | 26,47 |
| 48-37902A4  | 031042        | 933417  |        | 992114 | 993144 |        |        | 202 | 25    |
| 48-42522A10 | 032052        |         |        |        |        |        |        |     | 20    |
| 48-42522A11 | 032052        |         |        |        |        |        |        |     | 20    |
| 48-42522A12 | 032052        |         |        |        |        |        |        |     | 20    |
| 48-42738A10 | Black Max™    | 032141  |        |        |        |        |        |     | 24    |
| 48-42738A11 | Black Max™    | 032141  |        |        |        |        |        |     | 24    |
| 48-42738A13 | Black Max™    | 032141  |        |        |        |        |        |     | 24    |
| 48-42740A10 | Black Max™    | 032142  |        |        |        |        |        |     | 24    |
| 48-42740A11 | Black Max™    | 032142  |        |        |        |        |        |     | 24    |
| 48-43584A40 |               | 031049  |        | 992503 |        |        |        | 120 | 21    |
| 48-43586A40 |               | 031048  | 933015 | 992505 |        |        |        | 120 | 21    |
| 48-43590A40 |               |         |        | 992506 |        |        |        | 120 | 21    |
| 48-47670A3  |               | 032020  |        |        |        |        |        |     | 20    |
| 48-47922A10 |               | 032021  |        |        |        |        |        |     | 20    |
| 48-47926A10 |               | 032021  |        |        |        |        |        |     | 20    |
| 48-49632A4  |               | 031043  | 933419 | 992115 | 993145 |        |        | 202 | 25    |
| 48-49634A4  |               | 031052  |        | 992004 | 993044 | 993024 | 993204 | 202 | 26,47 |
| 48-52008A4  |               | 031045* |        |        |        |        |        |     | 25    |
| 48-52012A3  |               | 031045* |        |        |        |        |        |     | 25    |
| 48-53892A3  |               | 031043  | 933419 | 992115 | 993145 |        |        | 202 | 25    |
| 48-53896A4  |               | 031043  | 933419 | 992115 | 993145 |        |        | 202 | 25    |
| 48-53900A3  |               | 031041  | 933415 | 992113 | 993143 |        |        | 202 | 25    |
| 48-58422A4  |               | 031052  |        | 992004 | 993044 | 993024 | 993204 | 202 | 26,47 |
| 48-58424A4  |               | 031026  | 933521 | 992005 | 993045 | 993025 | 993205 | 202 | 26,47 |
| 48-58426A1  |               | 031026  | 933521 | 992005 | 993045 | 993025 | 993205 | 202 | 26,47 |
| 48-58426A4  |               |         |        | 992006 | 993046 | 993026 | 993206 | 202 | 26,47 |
| 48-58826A3  |               | 031254  |        | 992111 |        |        |        | 202 | 25    |
| 48-58826A4  |               | 031055  |        | 992112 |        |        |        | 202 | 25    |
| 48-61812A4  |               | 032045  |        | 992602 |        |        |        | 114 | 23    |
| 48-61814A4  |               | 032044  |        | 992603 |        |        |        | 114 | 23    |
| 48-61816A4  |               | 032043  | 993213 | 992604 | 993405 |        |        | 114 | 23    |
| 48-61818A4  |               | 032042  |        | 992605 | 993406 |        |        | 114 | 23    |
| 48-61820A4  |               | 032041  |        | 992606 | 993407 |        |        | 114 | 23    |
| 48-61822A4  |               | 032040  | 933215 | 992408 | 993408 |        |        | 114 | 23    |
| 48-61824A1  |               |         |        | 992409 |        |        |        | 114 | 23    |
| 48-62274A4  |               | 032045  |        | 992602 |        |        |        | 114 | 23    |
| 48-63540A1  |               | 032040  | 933215 | 992408 | 993408 |        |        | 114 | 23    |
| 48-64724A1  |               | 031020  |        |        |        |        |        |     | 24    |
| 48-64724A4  |               | 031020  |        |        |        |        |        |     | 24    |
| 48-65022A1  |               | 031041  |        | 992113 | 993143 |        |        | 202 | 25    |
| 48-65024A1  |               | 031042  |        | 992114 | 993144 |        |        | 202 | 25    |
| 48-65480A1  |               | 031027  |        | 992006 | 993046 | 993026 | 993206 | 202 | 26,47 |
| 48-65588A4  |               | 031043  | 933417 | 992114 | 993144 |        |        | 202 | 25    |
| 48-65736A4  |               | 031045* |        |        |        |        |        |     | 25    |
| 48-65748A1  |               | 031041  | 933415 | 992113 | 993143 |        |        | 202 | 25    |
| 48-65992A4  |               | 031026  | 933521 | 992005 | 993045 | 993025 | 993205 | 202 | 26,47 |
| 48-66432A4  |               | 031052  |        | 992004 | 993044 | 993024 | 993204 | 202 | 26,47 |
| 48-66450A4  |               | 031516  |        | 992003 | 993043 | 993023 | 993203 | 202 | 26,47 |
| 48-67280A1  |               | 031043  | 933419 | 992115 | 993145 |        |        | 202 | 25    |
| 48-67874A4  |               | 031027  |        | 992006 | 993046 |        | 993206 | 202 | 26,47 |
| 48-68556A4  | Cleaver™      |         |        | 992004 | 993044 | 993024 | 993204 | 202 | 26,47 |
| 48-68557A4  | Cleaver™ (LH) |         |        |        | 993055 | 993035 | 993215 | 202 | 26,47 |
| 48-68558A4  | Cleaver™      |         |        | 992005 | 993045 | 993025 | 993205 | 202 | 26,47 |
| 48-72764A5  | QSS™          | 031042  | 933417 | 992114 | 993144 |        |        | 202 | 25    |
| 48-73132A40 | Black Max™    | 031015  |        |        |        |        |        |     | 24    |
| 48-73134A40 | Black Max™    | 031016  |        | 992405 | 993405 |        |        | 114 | 24    |
| 48-73136A4  | Black Max™    | 031017  | 933213 | 992406 | 993406 |        |        | 114 | 24    |
| 48-73136A40 | Black Max™    | 031017  | 933213 | 992406 | 993406 |        |        | 114 | 24    |
| 48-73138A4  | Black Max™    | 031018  |        | 992407 | 993407 |        |        | 114 | 24    |
| 48-73138A40 | Black Max™    | 031018  |        | 992407 | 993407 |        |        | 114 | 24    |
| 48-73140A4  | Black Max™    | 031019  | 933215 | 992408 | 993408 |        |        | 114 | 24    |

# MICHIGAN WHEEL OEM CROSS REFERENCE

| Original Equipment Manufacturer<br>Part & Trade Mark |  | Standard<br>Hub<br>Propeller | XHS® / XHS II® Hub Propeller |                  |                |                 |                    | XHS® / XHS II®<br>Hub Kit(s) | Catalog Page #s |
|--|--|------------------------------|------------------------------|------------------|----------------|-----------------|--------------------|------------------------------|-----------------|
|  |  | Michigan<br>Match®           | Ballistic®                   | Ballistic®<br>XL | Vortex®<br>XHS | Apollo®<br>Std. | Apollo®<br>Lg. Dia |                              |                 |

## MERCURY®, MARINER®, MERCURISER® (Continued)

|             |                    |         |        |        |        |        |        |        |       |       |
|-------------|--------------------|---------|--------|--------|--------|--------|--------|--------|-------|-------|
| 48-73140A40 | Black Max™         | 031019  | 933215 |        | 992408 | 993408 |        | 114    | 24    |       |
| 48-73142A40 | Black Max™         |         |        |        | 992409 |        |        | 114    | 24    |       |
| 48-73144A4  | Black Max™         | 031020  |        |        |        |        |        |        | 24    |       |
| 48-73144A40 | Black Max™         | 031020  |        |        |        |        |        |        | 24    |       |
| 48-73502A4  |                    | 031513  |        |        | 992001 |        |        | 202    | 26,47 |       |
| 48-73504A4  |                    | 031023  | 933515 |        | 992002 | 993042 |        | 202    | 26,47 |       |
| 48-73506A4  |                    | 031024  | 933517 |        | 992003 | 993043 | 993023 | 993203 | 202   | 26,47 |
| 48-73508A4  |                    | 031025  | 933519 |        | 992004 | 993044 | 993024 | 993204 | 202   | 26,47 |
| 48-73510A4  |                    | 031026  | 933521 |        | 992005 | 993045 | 993025 | 993205 | 202   | 26,47 |
| 48-73512A4  |                    |         | 933523 |        | 992006 | 993046 | 993026 | 993206 | 202   | 26,47 |
| 48-73980A4  | QSS™               | 031025  | 933519 |        | 992004 | 993044 | 993024 | 993204 | 202   | 26,47 |
| 48-73980A5  | QSS™               | 031025  | 933519 |        | 992004 | 993044 | 993024 | 993204 | 202   | 26,47 |
| 48-73982A4  | QSS™               | 031026  | 933521 |        | 992005 | 993045 | 993025 | 993205 | 202   | 26,47 |
| 48-73982A5  | QSS™               | 031026  | 933521 |        | 992005 | 993045 | 993025 | 993205 | 202   | 26,47 |
| 48-74266A4  | QSS™               | 031025  | 933519 |        | 992004 | 993044 | 993024 | 993204 | 202   | 26,47 |
| 48-74268A4  | QSS™               | 031026  | 933521 |        | 992005 | 993045 | 993025 | 993205 | 202   | 26,47 |
| 48-74598A4  | Cleaver™           | 031025  | 933519 |        | 992004 | 993044 | 993024 | 993204 | 202   | 26,47 |
| 48-74599A4  | Cleaver™ (LH)      |         | 937521 |        |        | 993055 | 993035 | 993215 | 202   | 26,47 |
| 48-74600A4  | Cleaver™           | 031026  | 933521 |        | 992005 | 993045 | 993025 | 993205 | 202   | 26,47 |
| 48-74601A4  | Cleaver™ (LH)      |         | 937523 |        |        | 993056 | 993036 | 993216 | 202   | 26,47 |
| 48-74872A4  |                    | 031516  |        |        | 992003 | 993043 | 993023 | 993203 | 202   | 26,47 |
| 48-74874A4  |                    | 031052  |        |        | 992004 | 993044 | 993024 | 993204 | 202   | 26,47 |
| 48-74876A4  |                    | 031026  | 933521 |        | 992005 | 993045 | 993025 | 993205 | 202   | 26,47 |
| 48-74886A4  |                    | 031052  |        |        | 992004 | 993044 | 993024 | 993204 | 202   | 26,47 |
| 48-74888A4  |                    | 031026  | 933521 |        | 992005 | 993045 | 993025 | 993205 | 202   | 26,47 |
| 48-75058A4  | QSS™               |         | 933523 |        | 992006 | 993046 | 993026 | 993206 | 202   | 26,47 |
| 48-75160A4  |                    |         | 933523 |        | 992006 | 993046 | 993026 | 993206 | 202   | 26,47 |
| 48-75724A4  | QSS™               |         | 933523 |        | 992006 | 993046 | 993026 | 993206 | 202   | 26,47 |
| 48-75724A5  | QSS™               |         | 933523 |        | 992006 | 993046 | 993026 | 993206 | 202   | 26,47 |
| 48-75760A4  |                    | 031023  | 933515 |        | 992002 | 993042 |        | 202    | 26,47 |       |
| 48-76230A4  | QSS™               | 031058  |        |        | 992407 | 993407 |        | 114    | 24    |       |
| 48-76230A5  | Vengeance          | 031058  |        |        | 992407 | 993407 |        | 114    | 24    |       |
| 48-76232A4  | QSS™               | 031019  | 933215 |        | 992408 | 993408 |        | 114    | 24    |       |
| 48-76232A5  | Vengeance          | 031019  | 933215 |        | 992408 | 993408 |        | 114    | 24    |       |
| 48-77338A4  | Black Max™         | 031254  |        |        | 992111 |        |        | 202    | 25    |       |
| 48-77338A33 | Black Max™         | 031254  |        |        | 992111 |        |        | 202    | 25    |       |
| 48-77338A40 | Black Max™         | 031254  |        |        | 992111 |        |        | 202    | 25    |       |
| 48-77338A45 | Black Max™         | 031254  |        |        | 992111 |        |        | 202    | 25    |       |
| 48-77338CP1 | Black Max™ Pontoon |         |        |        | 941411 |        |        | 202    | 25    |       |
| 48-77340A4  | Black Max™         | 031055  |        |        | 992112 |        |        | 202    | 25    |       |
| 48-77340A33 | Black Max™         | 031055  |        |        | 992112 |        |        | 202    | 25    |       |
| 48-77340A40 | Black Max™         | 031055  |        |        | 992112 |        |        | 202    | 25    |       |
| 48-77340A45 | Black Max™         | 031055  |        |        | 992112 |        |        | 202    | 25    |       |
| 48-77340CP1 | Black Max™ Pontoon |         |        |        | 941413 |        |        | 202    | 25    |       |
| 48-77342A4  | Black Max™         | 031041  | 933415 |        | 992113 | 993143 |        | 202    | 25    |       |
| 48-77342A33 | Black Max™         | 031041  | 933415 |        | 992113 | 993143 |        | 202    | 25    |       |
| 48-77342A40 | Black Max™         | 031041  | 933415 |        | 992113 | 993143 |        | 202    | 25    |       |
| 48-77342A45 | Black Max™         | 031041  | 933415 |        | 992113 | 993143 |        | 202    | 25    |       |
| 48-77344A4  | Black Max™         | 031042  | 933417 |        | 992114 | 993144 |        | 202    | 25    |       |
| 48-77344A40 | Black Max™         | 031042  | 933417 |        | 992114 | 993144 |        | 202    | 25    |       |
| 48-77344A45 | Black Max™         | 031042  | 933417 |        | 992114 | 993144 |        | 202    | 25    |       |
| 48-77346A4  | Black Max™         | 031043  | 933419 |        | 992115 | 993145 |        | 202    | 25    |       |
| 48-77346A40 | Black Max™         | 031043  | 933419 |        | 992115 | 993145 |        | 202    | 25    |       |
| 48-77346A45 | Black Max™         | 031043  | 933419 |        | 992115 | 993145 |        | 202    | 25    |       |
| 48-77348A4  | Black Max™         | 031044  | 933421 | 953422 | 992116 | 993146 |        | 202    | 25    |       |
| 48-77348A40 | Black Max™         | 031044  | 933421 | 953422 | 992116 | 993146 |        | 202    | 25    |       |
| 48-77348A45 | Black Max™         | 031044  | 933421 | 953422 | 992116 | 993146 |        | 202    | 25    |       |
| 48-77350A4  | Black Max™         | 031045* |        |        |        |        |        |        | 25    |       |
| 48-77350A40 | Black Max™         | 031045* |        |        |        |        |        |        | 25    |       |
| 48-77350A45 | Black Max™         | 031045* |        |        |        |        |        |        | 25    |       |
| 48-78114A4  | Black Max™         | 031513  |        |        | 992001 |        |        | 202    | 26,47 |       |
| 48-78114A40 | Black Max™         | 031513  |        |        | 992001 |        |        | 202    | 26,47 |       |
| 48-78114A45 | Black Max™         | 031513  |        |        | 992001 |        |        | 202    | 26,47 |       |
| 48-78116A4  | Black Max™         | 031023  | 933515 |        | 992002 | 993042 |        | 202    | 26,47 |       |
| 48-78116A40 | Black Max™         | 031023  | 933515 |        | 992002 | 993042 |        | 202    | 26,47 |       |
| 48-78116A45 | Black Max™         | 031023  | 933515 |        | 992002 | 993042 |        | 202    | 26,47 |       |
| 48-78118A4  | Black Max™         | 031024  | 933517 |        | 992003 | 993043 | 993023 | 993203 | 202   | 26,47 |
| 48-78118A40 | Black Max™         | 031024  | 933517 |        | 992003 | 993043 | 993023 | 993203 | 202   | 26,47 |
| 48-78118A45 | Black Max™         | 031024  | 933517 |        | 992003 | 993043 | 993023 | 993203 | 202   | 26,47 |
| 48-78120A4  | Black Max™         | 031025  | 933519 |        | 992004 | 993044 | 993024 | 993204 | 202   | 26,47 |
| 48-78120A40 | Black Max™         | 031025  | 933519 |        | 992004 | 993044 | 993024 | 993204 | 202   | 26,47 |
| 48-78120A45 | Black Max™         | 031025  | 933519 |        | 992004 | 993044 | 993024 | 993204 | 202   | 26,47 |
| 48-78122A4  | Black Max™         | 031026  | 933521 | 953522 | 992005 | 993045 | 993025 | 993205 | 202   | 26,47 |

\* Indicates limited quantities.

# MICHIGAN WHEEL OEM CROSS REFERENCE

| Original Equipment Manufacturer<br>Part & Trade Mark | Standard<br>Hub<br>Propeller | XHS® / XHS II® Hub Propeller |                  |                |                 |                    |                    | XHS® / XHS II®<br>Hub Kit(s) | Catalog Page #s |
|--|------------------------------|------------------------------|------------------|----------------|-----------------|--------------------|--------------------|------------------------------|-----------------|
|  | Michigan<br>Match®           | Ballistic®                   | Ballistic®<br>XL | Vortex®<br>XHS | Apollo®<br>Std. | Apollo®<br>Lg. Dia | Apollo®<br>4-Blade |                              |                 |

## MERCURY®, MARINER®, MERCRUISER® (Continued)

|              |                   |        |        |        |        |        |        |        |     |       |
|--------------|-------------------|--------|--------|--------|--------|--------|--------|--------|-----|-------|
| 48-78122A40  | Black Max™        | 031026 | 933521 | 953522 | 992005 | 993045 | 993025 | 993205 | 202 | 26,47 |
| 48-78122A45  | Black Max™        | 031026 | 933521 | 953522 | 992005 | 993045 | 993025 | 993205 | 202 | 26,47 |
| 48-78124A4   | Black Max™        |        | 933523 | 953524 | 992006 | 993046 | 993026 | 993206 | 202 | 26,47 |
| 48-78124A40  | Black Max™        |        | 933523 | 953524 | 992006 | 993046 | 993026 | 993206 | 202 | 26,47 |
| 48-78124A45  | Black Max™        |        | 933523 | 953524 | 992006 | 993046 | 993026 | 993206 | 202 | 26,47 |
| 48-78126A4   | Black Max™        |        | 933525 | 953526 |        |        |        |        | 202 | 26,47 |
| 48-78126A40  | Black Max™        |        | 933525 | 953526 |        |        |        |        | 202 | 26,47 |
| 48-78126A45  | Black Max™        |        | 933525 | 953526 |        |        |        |        | 202 | 26,47 |
| 48-79572A4   | Black Max™        | 031516 | 933517 |        | 992003 | 993043 | 993023 | 993203 | 202 | 26,47 |
| 48-79574A4   | Black Max™        | 031025 | 933519 |        | 992004 | 993044 | 993024 | 993204 | 202 | 26,47 |
| 48-79576A4   | Black Max™        | 031026 | 933521 |        | 992005 | 993045 | 993025 | 993205 | 202 | 26,47 |
| 48-79578A4   | Black Max™        |        | 933523 |        | 992006 | 993046 | 993026 | 993206 | 202 | 26,47 |
| 48-79792A4   | QSS™              | 031016 |        |        | 992405 | 993405 |        |        | 114 | 24    |
| 48-79792A5   | Vengeance         | 031016 |        |        | 992405 | 993405 |        |        | 114 | 24    |
| 48-79794A4   | QSS™              | 031024 |        |        | 992003 | 993043 | 993023 | 993203 | 202 | 26,47 |
| 48-79794A5   | QSS™              | 031024 |        |        | 992003 | 993043 | 993023 | 993203 | 202 | 26,47 |
| 48-71645M    |                   | 022002 |        |        |        |        |        |        |     | 22    |
| 48-812950A02 |                   | 032055 |        |        |        |        |        |        |     | 20    |
| 48-81647M    |                   | 022001 |        |        |        |        |        |        |     | 22    |
| 48-81649M    |                   | 022002 |        |        |        |        |        |        |     | 20    |
| 48-816702A40 | Black Max™        | 031056 |        |        | 992405 | 993405 |        |        | 114 | 24    |
| 48-816704A40 | Black Max™        | 031057 | 933213 |        | 992406 | 993406 |        |        | 114 | 24    |
| 48-816706A40 | Black Max™        | 031058 |        |        | 992407 | 993407 |        |        | 114 | 24    |
| 48-825860A47 |                   | 031025 | 933519 |        | 992004 | 993044 | 993024 | 993204 | 202 | 26,47 |
| 48-825861A47 | Tempest Plus (LH) |        | 937519 |        |        | 993054 | 993034 | 993214 | 202 | 26,47 |
| 48-825862A47 | Tempest Plus      | 031026 | 933521 |        | 992005 | 993045 | 993025 | 993205 | 202 | 26,47 |
| 48-825863A47 | Tempest Plus (LH) |        | 937521 |        |        | 993055 | 993035 | 993215 | 202 | 26,47 |
| 48-825864A47 | Tempest Plus      |        | 933523 |        | 992006 | 993046 | 993026 | 993206 | 202 | 26,47 |
| 48-825865A47 | Tempest Plus (LH) |        | 937523 |        |        | 993056 | 993036 | 993216 | 202 | 26,47 |
| 48-825866A47 | Tempest Plus      |        | 933525 |        |        |        |        |        | 202 | 26,47 |
| 48-825872A47 | Tempest Plus      |        |        | 953524 |        |        |        |        | 202 | 26,47 |
| 48-825874A47 | Tempest Plus      |        |        | 953526 |        |        |        |        | 202 | 26,47 |
| 48-825898A48 | VenSura® 4        |        |        |        | 992202 |        |        | 993203 | 202 | 26,47 |
| 48-825899A48 | VenSura® 4 (LH)   |        |        |        |        |        |        | 993213 | 202 | 26,47 |
| 48-825900A48 | VenSura® 4        |        |        |        | 992203 |        |        | 993204 | 202 | 26,47 |
| 48-825901A48 | VenSura® 4 (LH)   |        |        |        |        |        |        | 993214 | 202 | 26,47 |
| 48-825902A48 | VenSura® 4        |        |        |        | 992204 |        |        | 993205 | 202 | 26,47 |
| 48-825903A48 | VenSura® 4 (LH)   |        |        |        |        |        |        | 993215 | 202 | 26,47 |
| 48-825906A48 | VenSura® 4        |        |        |        |        |        |        | 993206 | 202 | 26,47 |
| 48-825907A48 | VenSura® 4 (LH)   |        |        |        |        |        |        | 993216 | 202 | 26,47 |
| 48-825938A47 | Trophy Plus 4     |        |        | 963523 |        |        |        |        | 202 | 26    |
| 48-825942A47 | Trophy Plus 4     |        |        | 963525 |        |        |        |        | 202 | 26    |
| 48-825946A47 | Trophy Plus 4     |        |        | 963527 |        |        |        |        | 202 | 26    |
| 48-827312A11 | Black Max™        | 032142 |        |        |        |        |        |        |     | 24    |
| 48-82767     |                   | 012102 |        |        |        |        |        |        |     | 22    |
| 48-82768     |                   | 012011 |        |        |        |        |        |        |     | 22    |
| 48-828152A12 | Black Max™        | 032056 |        |        |        |        |        |        |     | 20    |
| 48-828154A12 | Black Max™        | 032053 |        |        |        |        |        |        |     | 20    |
| 48-828156A12 | Black Max™        | 032052 |        |        |        |        |        |        |     | 20    |
| 48-828158A12 | Black Max™        | 032050 |        |        |        |        |        |        |     | 20    |
| 48-82826     |                   | 022003 |        |        |        |        |        |        |     | 22    |
| 48-832828A45 | Black Max™        | 031064 | 933517 |        | 992003 | 993043 | 993023 | 993203 | 202 | 26,47 |
| 48-832830A45 | Black Max™        | 031065 | 933519 |        | 992004 | 993044 | 993024 | 993204 | 202 | 26,47 |
| 48-832832A45 | Black Max™        | 031066 | 933521 |        | 992005 | 993045 | 993025 | 993205 | 202 | 26,47 |
| 48-832834A45 | Black Max™        |        | 933523 |        | 992006 | 993046 | 993026 | 993206 | 202 | 26,47 |
| 48-834850A45 | Alpha 4®          |        |        |        | 992202 |        |        | 993203 | 202 | 26,47 |
| 48-834851A45 | Alpha 4® (LH)     |        |        |        |        |        |        | 993213 | 202 | 26,47 |
| 48-834852A45 | Alpha 4®          |        |        |        | 992203 |        |        | 993204 | 202 | 26,47 |
| 48-834853A45 | Alpha 4® (LH)     |        |        |        |        |        |        | 993214 | 202 | 26,47 |
| 48-834854A45 | Alpha 4®          |        |        |        | 992204 |        |        | 993205 | 202 | 26,47 |
| 48-834855A45 | Alpha 4® (LH)     |        |        |        |        |        |        | 993215 | 202 | 26,47 |
| 48-854342A45 |                   | 031061 |        |        | 992111 |        |        |        | 202 | 25    |
| 48-854354A46 | Vengeance         | 031041 | 933415 |        | 992113 | 993143 |        |        | 202 | 25    |
| 48-855856A5  | Vengeance         |        |        |        | 992405 | 993405 |        |        | 114 | 24    |
| 48-855858A5  | Vengeance         |        | 933213 |        | 992406 | 993406 |        |        | 114 | 24    |
| 48-855860A5  | Vengeance         |        |        |        |        | 993407 |        |        | 114 | 24    |
| 48-855862A5  | Vengeance         |        | 933215 |        |        | 993408 |        |        | 114 | 24    |
| 48-85632A4   | Black Max™        | 031053 |        |        | 992404 |        |        |        | 114 | 24    |
| 48-85632A40  | Black Max™        | 031053 |        |        | 992404 |        |        |        | 114 | 24    |
| 48-86848A4   |                   | 031048 |        |        |        |        |        |        |     | 21    |
| 48-86962A4   |                   | 032136 |        |        |        |        |        |        |     | 21    |
| 48-88438A4   | QSS™              |        |        |        |        | 993043 |        | 993203 | 202 | 26,47 |
| 48-88440A4   | QSS™              |        |        |        |        | 993044 |        | 993204 | 202 | 26,47 |

\* Indicates limited quantities.

# MICHIGAN WHEEL OEM CROSS REFERENCE

| Original Equipment Manufacturer<br>Part & Trade Mark |  | Standard<br>Hub<br>Propeller | XHS® / XHS II® Hub Propeller |                  |                |                 |                    | XHS® / XHS II®<br>Hub Kit(s) | Catalog Page #s |
|--|--|------------------------------|------------------------------|------------------|----------------|-----------------|--------------------|------------------------------|-----------------|
|  |  | Michigan<br>Match®           | Ballistic®                   | Ballistic®<br>XL | Vortex®<br>XHS | Apollo®<br>Std. | Apollo®<br>Lg. Dia |                              |                 |

## MERCURY®, MARINER®, MERCUISER® (Continued)

|              |                |         |        |  |        |        |        |        |       |
|--------------|----------------|---------|--------|--|--------|--------|--------|--------|-------|
| 48-88442A4   | QSS™           |         |        |  | 993045 |        | 993205 | 202    | 26,47 |
| 48-88444A4   | QSS™           |         |        |  | 993046 |        | 993206 | 202    | 26,47 |
| 48-896890A10 | Black Max™     | 141304  |        |  |        |        |        |        | 22    |
| 48-896892A40 | Black Max™     |         |        |  | 992501 |        |        | 122    | 22    |
| 48-896896A40 | Black Max™     |         |        |  | 992503 |        |        | 122    | 22    |
| 48-897618A10 | Black Max™     | 142203  |        |  |        |        |        |        | 21    |
| 48-897748A11 |                | 142203  |        |  |        |        |        |        | 21    |
| 48-897750A11 |                | 142204  |        |  |        |        |        |        | 21    |
| 48-897752A11 |                | 142205  |        |  |        |        |        |        | 21    |
| 48-897754A11 |                | 142206  |        |  |        |        |        |        | 21    |
| 48-89852A4   |                | 031049  |        |  | 992503 |        |        | 120    | 21    |
| 48-89854A4   |                |         |        |  | 992506 |        |        | 120    | 21    |
| 48-898990A46 | Enertia®       | 031023  | 933515 |  | 992002 | 993042 |        | 202    | 26,47 |
| 48-898991A46 | Enertia® (LH)  |         |        |  |        | 993052 |        | 202    | 26,47 |
| 48-898994A46 | Enertia®       | 031024  | 933517 |  | 992003 | 993043 | 993023 | 993203 | 202   |
| 48-898995A46 | Enertia® (LH)  |         | 937517 |  |        | 993053 | 993033 | 993213 | 202   |
| 48-898998A46 | Enertia®       | 031025  | 933519 |  | 992004 | 993044 | 993024 | 993204 | 202   |
| 48-898999A46 | Enertia® (LH)  |         | 937519 |  |        | 993054 | 993034 | 993214 | 202   |
| 48-899002A46 | Enertia®       | 031026  | 933521 |  | 992005 | 993045 | 993025 | 993205 | 202   |
| 48-899003A46 | Enertia® (LH)  |         | 937521 |  |        | 993055 | 993035 | 993215 | 202   |
| 48-899004A46 | Laser II™      | 031043  | 933419 |  | 992115 | 993145 |        | 202    | 25    |
| 48-899006A46 | Laser II™      | 031044  | 933421 |  | 992116 | 993146 |        | 202    | 25    |
| 48-90159A46  |                |         | 937517 |  |        | 993053 | 993033 | 993213 | 202   |
| 48-93272A4   | QSS™           | 031023  | 933515 |  | 992002 | 993042 |        | 202    | 26,47 |
| 48-93272A5   | QSS™           | 031023  | 933515 |  | 992002 | 993042 |        | 202    | 26,47 |
| 48-96623M    |                | 012013  |        |  |        |        |        |        | 22    |
| 48-96625M    |                | 012011  |        |  |        |        |        |        | 22    |
| 48-96628M    |                | 012102  |        |  |        |        |        |        | 22    |
| 8M8026560    | SpitFire®      |         |        |  | 941411 |        |        | 202    | 25    |
| 8M8026570    | SpitFire®      |         |        |  | 941413 |        |        | 202    | 25    |
| 8M8026580    | SpitFire®      |         |        |  | 941415 |        |        | 202    | 25    |
| 8M8026590    | SpitFire®      |         |        |  | 941417 |        |        | 202    | 25    |
| 8M8026600    | SpitFire®      |         |        |  | 941419 |        |        | 202    | 25    |
| QA1912X      | Black Diamond® | 031064  | 933517 |  | 992003 | 993043 | 993023 | 993203 | 202   |
| QA1916X      | Black Diamond® | 031065  | 933519 |  | 992004 | 993044 | 993024 | 993204 | 202   |
| QA1918X      | Black Diamond® | 031066  | 933521 |  | 992005 | 993045 | 993025 | 993205 | 202   |
| QA1920X      | Black Diamond® |         | 933523 |  | 992006 | 993046 | 993026 | 993206 | 202   |
| QA2004X      | Black Diamond® | 031513  |        |  |        |        |        |        | 24,41 |
| QA2006X      | Black Diamond® | 031050  | 933515 |  | 992002 | 993042 |        | 202    | 26,47 |
| QA2008X      | Black Diamond® | 031023  | 933515 |  | 992002 | 993042 |        | 202    | 26,47 |
| QA2010X      | Black Diamond® | 031516  | 933517 |  | 992003 | 993043 | 993023 | 993203 | 202   |
| QA2012X      | Black Diamond® | 031024  | 933517 |  | 992003 | 993043 | 993023 | 993203 | 202   |
| QA2014X      | Black Diamond® | 031052  | 933519 |  | 992004 | 993044 | 993024 | 993204 | 202   |
| QA2016X      | Black Diamond® | 031025  | 933519 |  | 992004 | 993044 | 993024 | 993204 | 202   |
| QA2018X      | Black Diamond® | 031026  | 933521 |  | 992005 | 993045 | 993025 | 993205 | 202   |
| QA2022X      | Black Diamond® |         | 933525 |  |        |        |        |        | 24,41 |
| QA2028X      | Black Diamond® | 031043  | 933419 |  | 992115 | 993145 |        | 202    | 25    |
| QA2030X      | Black Diamond® | 031254  |        |  | 992111 |        |        | 202    | 25    |
| QA2032X      | Black Diamond® | 031055  |        |  | 992112 |        |        | 202    | 25    |
| QA2034X      | Black Diamond® | 031041  | 933415 |  | 992113 | 993143 |        | 202    | 25    |
| QA2036X      | Black Diamond® | 031042  | 933417 |  | 992114 | 993144 |        | 202    | 25    |
| QA2038X      | Black Diamond® | 031043  | 933419 |  | 992115 | 993145 |        | 202    | 25    |
| QA2040X      | Black Diamond® | 031044  | 933421 |  | 992116 | 993146 |        | 202    | 25    |
| QA2042X      | Black Diamond® | 031045* |        |  |        |        |        |        | 25    |
| QA2060R      | Black Diamond® | 032141  |        |  |        |        |        |        | 24    |
| QA2064R      | Black Diamond® | 032044  |        |  | 992404 |        |        | 114    | 23    |
| QA2064R      | Black Diamond® | 031015  |        |  | 992404 |        |        | 114    | 23    |
| QA2066R      | Black Diamond® | 032142  |        |  |        |        |        |        | 24    |
| QA2070R      | Black Diamond® | 031053  |        |  | 992404 |        |        | 114    | 24    |
| QA2072R      | Black Diamond® | 031056  |        |  | 992405 | 993405 |        | 114    | 24    |
| QA2074R      | Black Diamond® | 031016  |        |  | 992405 | 993405 |        | 114    | 24    |
| QA2078R      | Black Diamond® | 032043  |        |  | 992405 | 993405 |        | 114    | 23    |
| QA2078R      | Black Diamond® | 031017  | 933213 |  | 992406 | 993406 |        | 114    | 24    |
| QA2078R      | Black Diamond® | 032042  | 993213 |  | 992406 | 993406 |        | 114    | 23    |
| QA2080R      | Black Diamond® | 031058  |        |  | 992407 | 993407 |        | 114    | 24    |
| QA2082R      | Black Diamond® | 031018  | 933215 |  | 992407 | 993407 |        | 114    | 24    |
| QA2082R      | Black Diamond® | 032041  |        |  | 992407 | 993407 |        | 114    | 23    |
| QA2084R      | Black Diamond® | 031019  | 933215 |  | 992408 | 993408 |        | 114    | 24    |
| QA2084R      | Black Diamond® | 032040  | 933215 |  | 992408 | 993408 |        | 114    | 23    |
| QA2088R      | Black Diamond® | 031020  |        |  |        |        |        |        | 24    |
| QA2102R      | Black Diamond® | 031049  |        |  | 992503 |        |        | 120    | 21    |
| QA2106R      | Black Diamond® | 031048  | 933013 |  | 992505 |        |        | 120    | 21    |
| QA2108R      | Black Diamond® |         | 933015 |  | 992506 |        |        | 120    | 21    |

\* Indicates limited quantities.

# MICHIGAN WHEEL OEM CROSS REFERENCE

| Original Equipment Manufacturer<br>Part & Trade Mark | Standard<br>Hub<br>Propeller | XHS® / XHS II® Hub Propeller |                  |                |                 |                    |                    | XHS® / XHS II®<br>Hub Kit(s) | Catalog Page #s |
|--|------------------------------|------------------------------|------------------|----------------|-----------------|--------------------|--------------------|------------------------------|-----------------|
|  | Michigan<br>Match®           | Ballistic®                   | Ballistic®<br>XL | Vortex®<br>XHS | Apollo®<br>Std. | Apollo®<br>Lg. Dia | Apollo®<br>4-Blade |                              |                 |

## MERCURY®, MARINER®, MERCRUISER® (Continued)

|         |                  |         |        |        |        |        |        |     |       |
|---------|------------------|---------|--------|--------|--------|--------|--------|-----|-------|
| QA2124R | Black Diamond®   | 032056  |        |        |        |        |        |     | 20    |
| QA2128R | Black Diamond®   | 032052  |        |        |        |        |        |     | 20    |
| QA2130R | Black Diamond®   | 032050  |        |        |        |        |        |     | 20    |
| QA2158R | Black Diamond®   | 142203  |        |        |        |        |        |     | 21    |
| QA2182X | Diamond 4        |         |        | 992202 |        |        | 993203 | 202 | 26,47 |
| QA2183X | Diamond 4 (LH)   |         |        |        |        |        | 993213 | 202 | 26,47 |
| QA2184X | Diamond 4        |         |        | 992203 |        |        | 993204 | 202 | 26,47 |
| QA2185X | Diamond 4 (LH)   |         |        |        |        |        | 993214 | 202 | 26,47 |
| QA2186X | Diamond 4        |         |        | 992204 |        |        | 993205 | 202 | 26,47 |
| QA2187X | Diamond 4 (LH)   |         |        |        |        |        | 993215 | 202 | 26,47 |
| QA2190R | Black Diamond®   | 141304  |        |        |        |        |        |     | 22    |
| QA2226R | Black Diamond®   | 032044  |        | 992603 | 993405 |        |        | 114 | 23    |
| QA2230R | Black Diamond®   | 032042  | 993213 | 992605 | 993406 |        |        | 114 | 23    |
| QA2232R | Black Diamond®   | 032041  |        | 992606 | 993407 |        |        | 114 | 23    |
| QA2234R | Black Diamond®   | 032040  | 993215 | 992408 | 993408 |        |        | 114 | 23    |
| QA2830X | Black Diamond®   |         |        | 941411 |        |        |        | 202 | 25    |
| QA2832X | Black Diamond®   |         |        | 941413 |        |        |        | 202 | 25    |
| QA3150R | Black Diamond®   | 012011  |        |        |        |        |        |     | 22    |
| QA3808R | Black Diamond®   | 022002  |        |        |        |        |        |     | 22    |
| QA3812R | Black Diamond®   | 022003  |        |        |        |        |        |     | 22    |
| QA6004  | QA3              | 031513  |        | 992001 |        |        |        | 202 | 26,47 |
| QA6010  | QA3              | 031516  |        | 931516 |        |        |        | 202 | 26,47 |
| QA6012  | QA3              | 031024  | 933517 | 992003 | 993043 | 993023 | 993203 | 202 | 26,47 |
| QA6016  | QA3              | 031025  | 933519 | 992004 | 993044 | 993024 | 993204 | 202 | 26,47 |
| QA6018  | QA3              | 031026  | 933521 | 992005 | 993045 | 993025 | 993205 | 202 | 26,47 |
| QA6020  | QA3              |         | 933523 | 992006 | 993046 | 993026 | 993206 | 202 | 26,47 |
| QA6030  | QA3              | 031254  |        | 992111 |        |        |        | 202 | 25    |
| QA6032  | QA3              | 031055  |        | 992112 |        |        |        | 202 | 25    |
| QA6034  | QA3              | 031041  |        | 992113 | 993143 |        |        | 202 | 25    |
| QA6036  | QA3              | 031042  |        | 992114 | 993144 |        |        | 202 | 25    |
| QA6038  | QA3              | 031043  |        | 992115 | 993145 |        |        | 202 | 25    |
| QA6040  | QA3              | 031044  |        | 992116 | 993146 |        |        | 202 | 25    |
| QA6042  | QA3              | 031045* |        |        |        |        |        |     | 25    |
| QA6060T | QA3              | 032141  |        |        |        |        |        |     | 24    |
| QA6064T | QA3              | 031015  |        |        |        |        |        |     | 24    |
| QA6070T | QA3              | 031053  |        | 992404 |        |        |        | 114 | 24    |
| QA6074T | QA3              | 031016  |        | 992405 | 993405 |        |        | 114 | 24    |
| QA6078T | QA3              | 031017  |        | 992406 | 993406 |        |        | 114 | 24    |
| QA6082T | QA3              | 031018  |        | 992407 | 993407 |        |        | 114 | 24    |
| QA6084T | QA3              | 031019  |        | 992408 | 993408 |        |        | 114 | 24    |
| QA6102T | QA3              | 031049  |        | 992503 |        |        |        | 120 | 21    |
| QA6106T | QA3              | 031048  | 993013 | 992505 |        |        |        | 120 | 21    |
| QA6128T | QA3              | 032021  |        |        |        |        |        |     | 20    |
| QS5004X | Thunderbolt      | 031064  | 993517 | 992003 | 993043 | 993023 | 993203 | 202 | 26,47 |
| QS5005X | Thunderbolt (LH) |         | 993517 |        | 993053 | 993033 | 993213 | 202 | 26,47 |
| QS5006X | Thunderbolt      | 031065  | 993519 | 992004 | 993044 | 993024 | 993204 | 202 | 26,47 |
| QS5007X | Thunderbolt (LH) |         | 993519 |        | 993054 | 993034 | 993214 | 202 | 26,47 |
| QS5008X | Thunderbolt      | 031066  | 993521 | 992005 | 993045 | 993025 | 993205 | 202 | 26,47 |
| QS5009X | Thunderbolt (LH) |         | 993521 |        | 993055 | 993035 | 993215 | 202 | 26,47 |
| QS5010X | Thunderbolt      |         | 993523 | 992006 | 993046 | 993026 | 993206 | 202 | 26,47 |
| QS5011X | Thunderbolt (LH) |         | 993523 |        | 993056 | 993036 | 993216 | 202 | 26,47 |
| QS5050X | Silverado        | 031023  | 993515 | 992002 | 993042 |        |        | 202 | 26,47 |
| QS5052X | Silverado        | 031024  | 993517 | 992003 | 993043 | 993023 | 993203 | 202 | 26,47 |
| QS5053X | Silverado (LH)   |         | 993517 |        | 993053 | 993033 | 993213 | 202 | 26,47 |
| QS5054X | Silverado        | 031025  | 993519 | 992004 | 993044 | 993024 | 993204 | 202 | 26,47 |
| QS5055X | Silverado (LH)   |         | 993519 |        | 993054 | 993034 | 993214 | 202 | 26,47 |
| QS5056X | Silverado        | 031026  | 993521 | 992005 | 993045 | 993025 | 993205 | 202 | 26,47 |
| QS5057X | Silverado (LH)   |         | 993521 |        | 993055 | 993035 | 993215 | 202 | 26,47 |
| QS5058X | Silverado        |         | 993523 | 992006 | 993046 | 993026 | 993206 | 202 | 26,47 |
| QS5059X | Silverado (LH)   |         | 993523 |        | 993056 | 993036 | 993216 | 202 | 26,47 |
| QS5070X | Lightspeed       | 031025  | 993519 | 992004 | 993044 | 993024 | 993204 | 202 | 26,47 |
| QS5071X | Lightspeed (LH)  |         | 993519 |        | 993054 | 993034 | 993214 | 202 | 26,47 |
| QS5072X | Lightspeed       | 031016  | 993521 | 992005 | 993045 | 993025 | 993205 | 202 | 26,47 |
| QS5073X | Lightspeed (LH)  |         | 993521 |        | 993055 | 993035 | 993215 | 202 | 26,47 |
| QS5074X | Lightspeed       |         | 993523 | 992006 | 993046 | 993026 | 993206 | 202 | 26,47 |
| QS5075X | Lightspeed (LH)  |         | 993523 |        | 993056 | 993036 | 993216 | 202 | 26,47 |
| QS5116X | Silverado        | 031041  | 993415 | 992113 | 993143 |        |        | 202 | 25    |
| QS6004X | Typhoon® 4       |         |        |        |        |        | 993204 | 202 | 26,47 |
| QS5118X | Silverado        | 031042  | 993417 | 992114 | 993144 |        |        | 202 | 25    |
| QS5120X | Silverado        | 031043  | 993419 | 992115 | 993145 |        |        | 202 | 25    |
| QS5122X | Silverado        | 031044  | 993421 | 992116 | 993146 |        |        | 202 | 25    |
| QS5124X | Silverado        |         | 953424 |        |        |        |        | 202 | 25    |
| QS5164R | Silverado        | 031056  |        | 992405 | 993405 |        |        | 114 | 24    |

\* Indicates limited quantities.

# MICHIGAN WHEEL OEM CROSS REFERENCE

| Original Equipment Manufacturer<br>Part & Trade Mark | Standard<br>Hub<br>Propeller | XHS® / XHS II® Hub Propeller |                  |                |                 |                    |                    | XHS® / XHS II®<br>Hub Kit(s) | Catalog Page #s |
|--|------------------------------|------------------------------|------------------|----------------|-----------------|--------------------|--------------------|------------------------------|-----------------|
|  | Michigan<br>Match®           | Ballistic®                   | Ballistic®<br>XL | Vortex®<br>XHS | Apollo®<br>Std. | Apollo®<br>Lg. Dia | Apollo®<br>4-Blade |                              |                 |

### MERCURY®, MARINER®, MERCUISER® (Continued)

|         |                   |        |        |        |        |        |        |     |       |
|---------|-------------------|--------|--------|--------|--------|--------|--------|-----|-------|
| QS5166R | Silverado         | 031057 | 933213 | 992406 | 993406 |        |        | 114 | 24    |
| QS5168R | Silverado         | 031058 | 933215 | 992407 | 993407 |        |        | 114 | 24    |
| QS5170R | Silverado         | 031058 | 933215 | 992408 | 993407 |        |        | 114 | 24    |
| QS5180R | Silverado         | 031048 | 933013 | 992505 |        |        |        | 120 | 21    |
| QS5862X | Torrent           | 031066 | 345143 | 992005 | 993045 | 993025 | 993205 | 202 | 26,47 |
| QS5864X | Torrent           |        | 933523 | 992006 | 993046 | 993026 | 993206 | 202 | 26,47 |
| QS6003X | Typhoon® 4 (LH)   |        |        |        |        |        | 993214 | 202 | 26,47 |
| QS6005X | Typhoon® 4 (LH)   |        |        |        |        |        | 993215 | 202 | 26,47 |
| QS6006X | Typhoon® 4        |        |        |        |        |        | 993205 | 202 | 26,47 |
| TA1916X | Black Diamond® XT | 031065 | 933519 | 992004 | 993044 | 993024 | 993204 | 202 | 26,47 |
| TA1918X | Black Diamond® XT | 031066 | 933521 | 992005 | 993045 | 993025 | 993205 | 202 | 26,47 |
| TA1920X | Black Diamond® XT |        | 933523 | 992006 | 993046 | 993026 | 993206 | 202 | 26,47 |
| TA2004X | Black Diamond®    | 031513 |        | 992001 |        |        |        | 202 | 26,47 |
| TA2008  | Black Diamond®    | 031023 |        | 992002 | 993042 |        |        | 202 | 26,47 |
| TA2010  | Black Diamond®    | 031516 |        | 992003 | 993043 | 993023 | 993203 | 202 | 26,47 |
| TA2012  | Black Diamond®    | 031024 |        | 992003 | 993043 | 993023 | 993203 | 202 | 26,47 |
| TA2014  | Black Diamond®    | 031052 |        | 992004 | 993044 | 993024 | 993204 | 202 | 26,47 |
| TA2016  | Black Diamond®    | 031025 |        | 992004 | 993044 | 993024 | 993204 | 202 | 26,47 |
| TA2018  | Black Diamond®    | 031026 |        | 992005 | 993045 | 993025 | 993205 | 202 | 26,47 |
| TA2020  | Black Diamond®    |        |        | 992006 | 993046 | 993026 | 993206 | 202 | 26,47 |
| TA2030X | Black Diamond®    | 031254 |        | 992111 |        |        |        | 202 | 25    |
| TA2032X | Black Diamond®    | 031055 |        | 992112 |        |        |        | 202 | 25    |
| TA2034  | Black Diamond®    | 031041 | 933415 | 992113 | 993143 |        |        | 202 | 25    |
| TA2036  | Black Diamond®    | 031042 | 933417 | 992115 | 993144 |        |        | 202 | 25    |
| TA2038  | Black Diamond®    | 031043 | 933419 | 992115 | 993145 |        |        | 202 | 25    |
| TA2040  | Black Diamond®    | 031044 | 933421 | 992116 | 993146 |        |        | 202 | 25    |
| TA2048  | Black Diamond®    | 031041 | 933415 | 992113 | 993143 |        |        | 202 | 25    |
| TA2050  | Black Diamond®    | 031042 | 933417 | 992114 | 993144 |        |        | 202 | 25    |
| TA2052  | Black Diamond®    | 031043 | 933419 | 992115 | 993145 |        |        | 202 | 25    |
| TA2054  | Black Diamond®    | 031044 | 933421 | 992116 | 993146 |        |        | 202 | 25    |
| TA2060T | Black Diamond®    | 032141 |        |        |        |        |        |     | 24    |
| TA2064T | Black Diamond®    | 031015 |        |        |        |        |        |     | 24    |
| TA2066T | Black Diamond®    | 032142 |        |        |        |        |        |     | 24    |
| TA2070T | Black Diamond®    | 031053 |        | 992404 |        |        |        | 114 | 24    |
| TA2072T | Black Diamond®    | 031056 |        | 992405 | 993405 |        |        | 114 | 24    |
| TA2074T | Black Diamond®    | 031016 |        | 992405 | 993405 |        |        | 114 | 24    |
| TA2076T | Black Diamond®    | 031057 | 933213 | 992406 | 993406 |        |        | 114 | 24    |
| TA2078T | Black Diamond®    | 031017 | 933213 | 992406 | 993406 |        |        | 114 | 24    |
| TA2080T | Black Diamond®    | 031058 |        | 992407 | 993407 |        |        | 114 | 24    |
| TA2082T | Black Diamond®    | 031018 |        | 992407 | 993407 |        |        | 114 | 24    |
| TA2084T | Black Diamond®    | 031019 | 933215 | 992408 | 993408 |        |        | 114 | 24    |
| TA2088T | Black Diamond®    | 031513 |        | 992001 |        |        |        | 202 | 26,47 |
| TA2106T | Black Diamond®    | 031048 |        | 992505 |        |        |        | 120 | 21    |
| TA2128T | Black Diamond®    | 032052 |        |        |        |        |        |     | 20    |
| TA2202  | Black Diamond®    | 031044 | 933421 | 992116 | 993146 |        |        | 202 | 25    |
| TA2204  | Black Diamond®    | 031043 | 933419 | 992115 | 993145 |        |        | 202 | 25    |
| TA2206  | Black Diamond®    | 031042 | 933417 | 992114 | 993144 |        |        | 202 | 25    |
| TA2208  | Black Diamond®    | 031041 | 933415 | 992113 | 993143 |        |        | 202 | 25    |
| TA3150T | Black Diamond®    | 012011 |        |        |        |        |        |     | 22    |
| TA3152T | Black Diamond®    | 012013 |        |        |        |        |        |     | 22    |
| TA3808T | Black Diamond®    | 022002 |        |        |        |        |        |     | 22    |
| TS1006  | Thunderbolt       |        |        | 992004 | 993044 | 993024 | 993204 | 202 | 26,47 |
| TS1007  | Thunderbolt (LH)  |        |        |        | 993054 | 993034 | 993214 | 202 | 26,47 |
| TS1008  | Thunderbolt       |        |        | 992005 | 993045 | 993025 | 993205 | 202 | 26,47 |
| TS1009  | Thunderbolt (LH)  |        |        |        | 993055 | 993035 | 993215 | 202 | 26,47 |
| TS1010  | Thunderbolt       |        |        | 992006 | 993046 | 993026 | 993206 | 202 | 26,47 |
| TS1011  | Thunderbolt (LH)  |        |        |        | 993056 | 993036 | 993216 | 202 | 26,47 |
| TS1052  | Silverado         | 031064 | 933517 | 992003 | 993043 | 993023 | 993203 | 202 | 26,47 |
| TS1053  | Silverado (LH)    |        | 937517 |        | 993053 | 993033 | 993213 | 202 | 26,47 |
| TS1054  | Silverado         | 031065 | 933519 | 992004 | 993044 | 993024 | 993204 | 202 | 26,47 |
| TS1055  | Silverado (LH)    |        | 937519 |        | 993054 | 993034 | 993214 | 202 | 26,47 |
| TS1056  | Silverado         | 031066 | 933521 | 992005 | 993045 | 993025 | 993205 | 202 | 26,47 |
| TS1057  | Silverado (LH)    |        | 937521 |        | 993055 | 993035 | 993215 | 202 | 26,47 |
| TS1070  | Lightspeed        | 031065 | 933519 | 992004 | 993044 | 993024 | 993204 | 202 | 26,47 |
| TS1071  | Lightspeed (LH)   |        | 937519 |        | 993054 | 993034 | 993214 | 202 | 26,47 |
| TS1072  | Lightspeed        | 031066 | 933521 | 992005 | 993045 | 993025 | 993205 | 202 | 26,47 |
| TS1073  | Lightspeed (LH)   |        | 937521 |        | 993055 | 993035 | 993215 | 202 | 26,47 |
| TS1074  | Lightspeed        |        | 933523 | 992006 | 993046 | 993026 | 993206 | 202 | 26,47 |
| TS1075  | Lightspeed (LH)   |        | 937523 |        | 993056 | 993036 | 993216 | 202 | 26,47 |
| TS1116  | Silverado         | 031041 | 933415 | 992113 | 993143 |        |        | 202 | 25    |
| TS1118  | Silverado         | 031042 | 933417 | 992114 | 993144 |        |        | 202 | 25    |
| TS1120  | Lightspeed        | 031043 | 933419 | 992115 | 993145 |        |        | 202 | 25    |
| TS1122  | Lightspeed        | 031044 | 933421 | 992116 | 993146 |        |        | 202 | 25    |

# MICHIGAN WHEEL OEM CROSS REFERENCE

| Original Equipment Manufacturer<br>Part & Trade Mark | Standard<br>Hub<br>Propeller | XHS® / XHS II® Hub Propeller |                  |                |                 |                    | XHS® / XHS II®<br>Hub Kit(s) | Catalog Page #s |
|--|------------------------------|------------------------------|------------------|----------------|-----------------|--------------------|------------------------------|-----------------|
|  | Michigan<br>Match®           | Ballistic®                   | Ballistic®<br>XL | Vortex®<br>XHS | Apollo®<br>Std. | Apollo®<br>Lg. Dia |                              |                 |

### MERCURY®, MARINER®, MERCRUISER® (Continued)

|                             |             |             |             |             |          |    |
|-----------------------------|-------------|-------------|-------------|-------------|----------|----|
| TS1164T..... Silverado..... | 031016..... |             | 992305..... | 993405..... | 114..... | 24 |
| TS1166T..... Silverado..... | 031017..... | 933213..... | 992406..... | 993406..... | 114..... | 24 |
| TS1168T..... Silverado..... | 031058..... |             | 992407..... | 993407..... | 114..... | 24 |

### NISSAN®, TOHATSU®

|                 |              |             |             |             |          |    |
|-----------------|--------------|-------------|-------------|-------------|----------|----|
| 345641015.....  | 141304.....  |             | 992501..... |             | 122..... | 28 |
| 346641015M..... | 141304.....  |             | 992501..... |             | 122..... | 28 |
| 346641025M..... | 141307.....  |             | 992502..... |             | 122..... | 28 |
| 346641035.....  | 141305.....  |             | 992503..... |             | 122..... | 28 |
| 346641035M..... | 141305.....  |             | 992503..... |             | 122..... | 28 |
| 346641045M..... | 141306.....  |             | 992505..... |             | 122..... | 28 |
| 346641055.....  |              |             | 992506..... |             | 122..... | 28 |
| 346641055M..... |              |             | 992506..... |             | 122..... | 28 |
| 346641065.....  | 141304.....  |             |             |             |          | 28 |
| 346B641065..... | 141304.....  |             |             |             |          | 28 |
| 346W641055..... |              |             | 992506..... |             | 122..... | 28 |
| 346W641065..... | 141304.....  |             |             |             |          | 28 |
| 348641020.....  | 142406.....  |             | 992605..... | 993406..... | 116..... | 29 |
| 348641030.....  | 142410.....  |             | 992606..... | 993407..... | 116..... | 29 |
| 348641040.....  | 142409.....  |             | 992604..... | 993405..... | 116..... | 29 |
| 348641080.....  |              |             | 992401..... |             | 112..... | 29 |
| 348W641080..... |              |             | 992401..... |             | 116..... | 29 |
| 349B645291..... | 142309.....  |             |             |             |          | 28 |
| 353641010.....  |              |             | 992401..... |             | 112..... | 29 |
| 353641020.....  |              |             | 992402..... |             | 112..... | 29 |
| 353641030.....  |              |             | 992403..... |             | 112..... | 29 |
| 353641050.....  |              |             | 992301..... |             | 112..... | 29 |
| 353641050M..... |              |             | 992301..... |             | 112..... | 29 |
| 353641070.....  |              |             | 992302..... |             | 112..... | 29 |
| 353641070M..... |              |             | 992302..... |             | 112..... | 29 |
| 353641080.....  | 142008*..... |             |             |             |          | 29 |
| 353641090.....  |              |             | 992303..... |             | 112..... | 29 |
| 353641090M..... |              |             | 992303..... |             | 112..... | 29 |
| 361641020.....  | 142406.....  |             | 992605..... | 993406..... | 116..... | 29 |
| 361641030.....  | 142410.....  |             | 992606..... | 993407..... | 116..... | 29 |
| 361641130.....  | 142405.....  |             | 992603..... |             | 116..... | 29 |
| 361641140.....  | 142002.....  |             | 992604..... | 993405..... | 116..... | 29 |
| 362B641010..... | 142204.....  |             |             |             |          | 28 |
| 362B641080..... | 142205.....  |             |             |             |          | 28 |
| 362641010M..... | 142204.....  |             |             |             |          | 28 |
| 362641020.....  | 142203.....  |             |             |             |          | 28 |
| 362641020M..... | 142203.....  |             |             |             |          | 28 |
| 362641080M..... | 142205.....  |             |             |             |          | 28 |
| 362W641020..... | 142203.....  |             |             |             |          | 28 |
| 3BAB645161..... | 142203.....  |             |             |             |          | 28 |
| 3B2B645140..... | 142102.....  |             |             |             |          | 28 |
| 3B2B645151..... | 142103.....  |             |             |             |          | 28 |
| 3B7645270.....  |              |             | 992112..... |             | 209..... | 31 |
| 3B7645320.....  | 142215.....  | 933415..... | 992113..... | 993143..... | 209..... | 31 |
| 3B7645360.....  | 142215.....  | 933415..... | 992113..... | 993143..... | 209..... | 31 |
| 3B7645410.....  | 142217.....  | 933417..... | 992114..... | 993144..... | 209..... | 31 |
| 3B7645450.....  | 142219.....  | 933419..... | 992115..... | 993145..... | 209..... | 31 |
| 3B7645490.....  | 142221.....  | 933421..... |             |             | 209..... | 31 |
| 3C7645140.....  | 142217.....  | 933417..... | 992114..... | 993144..... | 209..... | 31 |
| 3C7645360.....  | 142217.....  | 933417..... | 992114..... | 993144..... | 209..... | 31 |
| 3C7645360M..... | 142215.....  | 933415..... | 992113..... | 993143..... | 209..... | 31 |
| 3C7645490M..... | 142219.....  | 933419..... | 992115..... | 993145..... | 209..... | 31 |
| 3C7645540M..... | 142221.....  | 933421..... | 992116..... | 993146..... | 209..... | 31 |
| 3C7764510M..... | 142217.....  | 933417..... | 992114..... | 993144..... | 209..... | 31 |
| 3E0641810M..... |              |             | 992112..... |             | 209..... | 31 |
| 3E0641850M..... | 142215.....  | 933415..... | 992113..... | 993143..... | 209..... | 31 |
| 3E0641890M..... | 142217.....  | 933417..... | 992114..... | 993144..... | 209..... | 31 |
| 3E0641940M..... | 142219.....  | 933419..... | 992115..... | 993145..... | 209..... | 31 |
| 3E0641960M..... | 142221.....  | 933421..... | 992116..... | 993146..... | 209..... | 31 |
| 3E3645260M..... | 142409.....  |             | 992604..... | 993405..... | 116..... | 29 |
| 3E3645280M..... | 142406.....  |             | 992605..... | 993406..... | 116..... | 29 |
| 3E3645310M..... | 142410.....  |             | 992606..... | 993407..... | 116..... | 29 |
| 3E3645360M..... |              |             | 992408..... | 993408..... | 116..... | 29 |
| 3N4B645271..... | 142213.....  |             |             |             |          | 31 |
| 3N4B645321..... | 142215.....  |             |             |             |          | 31 |
| 3N4B645361..... | 142217.....  |             |             |             |          | 31 |
| 3N4B645411..... | 142219.....  |             |             |             |          | 31 |
| 3N4B645451..... | 142221.....  |             |             |             |          | 31 |

\* Indicates limited quantities.

# MICHIGAN WHEEL OEM CROSS REFERENCE

| Original Equipment Manufacturer<br>Part & Trade Mark | Standard<br>Hub<br>Propeller | XHS® / XHS II® Hub Propeller |                  |                |                 |                    | XHS® / XHS II®<br>Hub Kit(s) | Catalog Page #s |
|--|------------------------------|------------------------------|------------------|----------------|-----------------|--------------------|------------------------------|-----------------|
|  | Michigan<br>Match®           | Ballistic®                   | Ballistic®<br>XL | Vortex®<br>XHS | Apollo®<br>Std. | Apollo®<br>Lg. Dia |                              |                 |

## NISSAN®, TOHATSU® (Continued)

|              |               |        |        |        |        |        |     |    |
|--------------|---------------|--------|--------|--------|--------|--------|-----|----|
| 3N4W645271   | 142213        |        |        | 992112 |        |        | 209 | 31 |
| 3N4W645321   | 142215        | 933415 |        | 992113 | 993143 |        | 209 | 31 |
| 3N4W645361   | 142217        | 933417 |        | 992114 | 993144 |        | 209 | 31 |
| 3N4W645411   | 142219        | 933419 |        | 992115 | 993145 |        | 209 | 31 |
| 3N4W645451   | 142221        | 933421 |        | 992116 | 993146 |        | 209 | 31 |
| 3R0645250M   | 141308        |        |        | 992504 |        |        | 122 | 28 |
| 3R0B645180   | 141304        |        |        | 992501 |        |        | 122 | 28 |
| 3R0B645210   | 141307        |        |        |        |        |        |     | 28 |
| 3R0B645230   | 141305        |        |        | 992503 |        |        | 122 | 28 |
| 3R0B645250   | 141308        |        |        |        |        |        |     | 28 |
| 3R0B645270   | 141306        |        |        | 992505 |        |        | 122 | 28 |
| 3R0W645210   | 141307        |        |        | 992502 |        |        | 122 | 28 |
| 3R0W645230   | 141305        |        |        | 992503 |        |        | 122 | 28 |
| 3R0W645250   | 141308        |        |        | 992504 |        |        | 122 | 28 |
| 3R0W645270   | 141306        |        |        | 992505 |        |        | 122 | 28 |
| 3R0W645480   | 141304        |        |        | 992501 |        |        | 122 | 28 |
| 3T5B645180   | 142407        |        |        |        |        |        |     | 29 |
| 3T5B645230   | 142405        |        |        |        |        |        |     | 29 |
| 3T5B645250   | 142409        |        |        |        |        |        |     | 29 |
| 3T5B645270   | 142406        |        |        |        |        |        |     | 29 |
| 3T5B645290   | 142410        |        |        |        |        |        |     | 29 |
| 3T5B645320   | 142405        |        |        | 992603 |        |        | 116 | 29 |
| 3T5645230    | 142405        |        |        | 992603 |        |        | 116 | 29 |
| 3T5645250    | 142409        |        |        | 992604 | 993405 |        | 116 | 29 |
| 3T5645270    | 142406        |        |        | 992605 | 993406 |        | 116 | 29 |
| 3T5645290    | 142410        |        |        | 992606 | 993407 |        | 116 | 29 |
| 3T5645320    |               |        |        | 992408 | 993408 |        | 116 | 29 |
| 9999RUBA313M | Solas® Rubex® | 142213 |        | 992112 |        |        | 209 | 31 |
| 9999RUBA315M | Solas® Rubex® | 142215 |        | 992113 | 993143 |        | 209 | 31 |
| 9999RUBA317M | Solas® Rubex® | 142217 |        | 992114 | 993144 |        | 209 | 31 |
| 9999RUBA319M | Solas® Rubex® | 142219 |        | 992115 | 993145 |        | 209 | 31 |
| 9999RUBA321M | Solas® Rubex® | 142221 |        | 992116 | 993146 |        | 209 | 31 |
| 9999RUBE315M | Solas® Rubex® |        |        | 992002 |        |        | 207 | 32 |
| 9999RUBE317M | Solas® Rubex® |        |        | 992003 |        |        | 207 | 32 |
| 9999RUBE319M | Solas® Rubex® |        |        | 992004 |        |        | 207 | 32 |
| 9999RUBE321M | Solas® Rubex® |        |        | 992005 |        |        | 207 | 32 |
| 9999RUBH309M | Solas® Rubex® |        |        | 992601 |        |        | 116 | 29 |
| 9999RUBH310M | Solas® Rubex® |        |        | 992602 |        |        | 116 | 29 |
| 9999RUBH311M | Solas® Rubex® |        |        | 992603 |        |        | 116 | 29 |
| 9999RUBH312M | Solas® Rubex® |        |        | 992604 |        |        | 116 | 29 |
| 9999RUBH313M | Solas® Rubex® |        |        | 992605 |        |        | 116 | 29 |
| 9999RUBH314M | Solas® Rubex® |        |        | 992606 |        |        | 116 | 29 |
| NM889210130  |               | 933013 |        |        |        |        | 122 | 28 |
| NM889410120  |               | 142409 |        | 992604 | 993405 |        | 116 | 29 |
| NM889410130  |               | 142406 |        | 992605 | 993406 |        | 116 | 29 |
| NM889410140  |               | 142410 |        | 992606 | 993407 |        | 116 | 29 |
| NM889410150  |               |        |        | 992408 | 993408 |        | 116 | 29 |
| NM889510150  |               | 933315 |        |        |        |        | 112 | 29 |
| NM889510170  |               | 933317 |        |        |        |        | 112 | 29 |
| NM889610150  |               | 142215 | 933415 | 992113 | 993143 |        | 209 | 31 |
| NM889610170  |               | 142217 | 933417 | 992114 | 993144 |        | 209 | 31 |
| NM889610180  |               | 142219 | 933419 | 992115 | 993145 |        | 209 | 31 |
| NM889610200  |               | 142221 | 933421 | 992116 | 993146 |        | 209 | 31 |
| PTOFS3R17P   |               |        |        |        |        | 993023 | 207 | 32 |
| PTPTZ3R17P   |               |        |        |        | 993043 |        | 207 | 32 |
| PTPTZ3L19P   |               |        |        |        | 993054 |        | 207 | 32 |
| PTPTZ3R19P   |               |        |        |        | 993044 |        | 207 | 32 |
| PTPTZ3L21P   |               |        |        |        | 993055 |        | 207 | 32 |
| PTPTZ3R21P   |               |        |        |        | 993045 |        | 207 | 32 |

## SUZUKI®

|                 |                     |        |  |        |        |  |            |    |
|-----------------|---------------------|--------|--|--------|--------|--|------------|----|
| 58100-87L00-019 |                     |        |  | 992112 |        |  | See Note 4 | 36 |
| 58100-87L10-019 |                     | 061020 |  | 992113 | 993143 |  | See Note 4 | 36 |
| 58100-87L20-019 |                     | 061024 |  | 992114 | 993144 |  | See Note 4 | 36 |
| 58100-85L30-019 |                     | 061028 |  | 992115 | 993145 |  | See Note 4 | 36 |
| 58100-87L40-019 |                     | 061032 |  | 992116 | 993146 |  | See Note 4 | 36 |
| 58100-88L01-019 | DF40A/50A/60A/40/50 | 032046 |  | 992601 |        |  | 115        | 34 |
| 58100-88L10-019 | DF40A/50A/60A/40/50 | 032045 |  | 992602 |        |  | 115        | 34 |
| 58100-88L21-019 | DF40A/50A/60A/40/50 | 062211 |  | 992603 |        |  | 115        | 34 |
| 58100-88L31-019 | DF40A/50A/60A/40/50 | 062212 |  | 992604 |        |  | 115        | 34 |
| 58100-88L41-019 | DF40A/50A/60A/40/50 | 062213 |  | 992605 |        |  | 115        | 34 |
| 58100-88L51-019 | DF40A/50A/60A/40/50 | 062214 |  | 992606 |        |  | 115        | 34 |

\* Indicates limited quantities.



# MICHIGAN WHEEL OEM CROSS REFERENCE

| Original Equipment Manufacturer<br>Part & Trade Mark | Standard<br>Hub<br>Propeller | XHS® / XHS II® Hub Propeller |                  |                |                 |                    |                    | XHS® / XHS II®<br>Hub Kit(s) | Catalog Page #s |
|--|------------------------------|------------------------------|------------------|----------------|-----------------|--------------------|--------------------|------------------------------|-----------------|
|  | Michigan<br>Match®           | Ballistic®                   | Ballistic®<br>XL | Vortex®<br>XHS | Apollo®<br>Std. | Apollo®<br>Lg. Dia | Apollo®<br>4-Blade |                              |                 |

## SUZUKI® (Continued)

|                 |                     |        |         |  |        |        |        |            |     |    |
|-----------------|---------------------|--------|---------|--|--------|--------|--------|------------|-----|----|
| 58100-88L61-019 | DF40A/50A/60A/40/50 | 062215 |         |  |        |        |        |            |     | 34 |
| 58100-88L71-019 |                     | 062216 |         |  |        |        |        |            |     | 34 |
| 58100-88L81-019 |                     | 062217 |         |  |        |        |        |            |     | 34 |
| 58100-90420-019 |                     | 061032 |         |  | 992116 | 993146 |        | See Note 4 |     | 36 |
| 58100-90J00-019 |                     | 061024 |         |  | 992114 | 993144 |        | See Note 4 |     | 36 |
| 58100-90J01-019 |                     | 061024 |         |  | 992114 | 993144 |        | See Note 4 |     | 36 |
| 58100-90J10-019 |                     | 061028 |         |  | 992115 | 993145 |        | See Note 4 |     | 36 |
| 58100-90J11-019 |                     | 061028 |         |  | 992115 | 993145 |        | See Note 4 |     | 36 |
| 58100-90J20-019 |                     | 061032 |         |  | 992116 | 993146 |        | See Note 4 |     | 36 |
| 58100-90J21-019 |                     | 061032 |         |  | 992116 | 993146 |        | See Note 4 |     | 36 |
| 58100-90J41-019 |                     | 061020 |         |  | 992113 | 993143 |        | See Note 4 |     | 36 |
| 58100-90L50-019 |                     | 062103 |         |  |        |        |        |            |     | 33 |
| 58100-93723-019 |                     | 062103 |         |  |        |        |        |            |     | 33 |
| 58100-93733-019 |                     | 062104 |         |  |        |        |        |            |     | 33 |
| 58100-93743-019 |                     | 062105 |         |  |        |        |        |            |     | 33 |
| 58100-93763-019 |                     | 062103 |         |  |        |        |        |            |     | 33 |
| 58100-93773-019 |                     | 062104 |         |  |        |        |        |            |     | 33 |
| 58100-94J00-019 |                     | 062103 |         |  |        |        |        |            |     | 33 |
| 58100-94313-019 |                     | 062213 | 993213  |  | 992605 | 993406 |        | 115        |     | 34 |
| 58100-94410     |                     |        |         |  | 992606 | 993407 |        | 115        |     | 34 |
| 58100-94411     |                     |        |         |  | 992606 | 993407 |        | 115        |     | 34 |
| 58100-94412     |                     |        |         |  | 992606 | 993407 |        | 115        |     | 34 |
| 58100-94500-019 |                     | 061101 |         |  | 992113 | 993143 |        | 210        |     | 35 |
| 58100-94512-019 |                     | 061102 |         |  | 992114 | 993144 |        | 210        |     | 35 |
| 58100-94522-019 |                     | 061103 |         |  | 992115 | 993145 |        | 210        |     | 35 |
| 58100-94532-019 |                     | 061104 |         |  | 992116 | 993146 |        | 210        |     | 35 |
| 58100-94554     |                     | 061101 |         |  | 992113 | 993143 |        | 210        |     | 35 |
| 58100-94561     |                     | 061103 |         |  | 992115 | 993145 |        | 210        |     | 35 |
| 58100-94571     |                     | 061104 |         |  | 992116 | 993146 |        | 210        |     | 35 |
| 58100-94581     |                     | 061102 |         |  | 992114 | 993144 |        | 210        |     | 35 |
| 58100-95212-019 |                     | 032045 |         |  | 992602 |        |        | 115        |     | 34 |
| 58100-95222-019 |                     | 062211 |         |  | 992603 |        |        | 115        |     | 34 |
| 58100-95353-019 |                     | 062214 |         |  | 992606 | 993406 |        | 115        |     | 34 |
| 58100-95363-019 |                     | 062215 | 993213  |  | 992408 | 993407 |        | 115        |     | 34 |
| 58100-95373-019 |                     |        |         |  | 992409 | 993408 |        | 115        |     | 34 |
| 58100-95382-019 |                     |        | 993215  |  |        |        |        | 115        |     | 34 |
| 58100-95393-019 |                     | 062212 |         |  | 992604 | 993405 |        | 115        |     | 34 |
| 58100-95500-019 |                     | 061101 |         |  | 992113 | 993143 |        | 210        |     | 35 |
| 58100-95511-019 |                     | 061102 |         |  | 992114 | 993144 |        | 210        |     | 35 |
| 58100-95521-019 |                     | 061103 |         |  | 992115 | 993145 |        | 210        |     | 35 |
| 58100-95530-019 |                     | 061104 |         |  | 992116 | 993146 |        | 210        |     | 35 |
| 58100-95D00-019 |                     |        |         |  | 992506 |        |        | 121        |     | 33 |
| 58100-95D01-019 |                     | 062209 |         |  |        |        |        |            |     | 33 |
| 58100-96370-019 |                     |        |         |  | 992501 |        |        | 121        |     | 33 |
| 58100-96371-019 |                     | 062208 |         |  |        |        |        |            |     | 33 |
| 58100-96410-019 |                     | 062204 |         |  | 992502 |        |        | 121        |     | 33 |
| 58100-96420-019 |                     | 062205 |         |  | 992503 |        |        | 121        |     | 33 |
| 58100-96421-019 |                     | 062205 |         |  |        |        |        |            |     | 33 |
| 58100-96430-019 |                     | 062206 |         |  | 992504 |        |        | 121        |     | 33 |
| 58100-96440-019 |                     | 062207 | 9933013 |  | 992505 |        |        | 121        |     | 33 |
| 58100-96460-019 |                     |        | 993015  |  |        |        |        | 121        |     | 33 |
| 58100-96461-019 |                     | 062210 |         |  |        |        |        |            |     | 33 |
| 58100-96470-019 |                     | 062204 |         |  | 992502 |        |        | 121        |     | 33 |
| 58100-96471-019 |                     | 062204 |         |  | 992502 |        |        | 121        |     | 33 |
| 58100-96480-019 |                     | 062206 |         |  | 992504 |        |        | 121        |     | 33 |
| 58100-96481-019 |                     | 062206 |         |  | 992504 |        |        | 121        |     | 33 |
| 58100-96490-019 |                     | 062207 | 9933013 |  | 992505 |        |        | 121        |     | 33 |
| 58100-96491-019 |                     | 062207 | 9933013 |  | 992505 |        |        | 121        |     | 33 |
| 58100-99E00-019 |                     | 061105 |         |  | 992112 |        |        | 210        |     | 35 |
| 58100-99E10-019 |                     | 061107 |         |  | 992111 |        |        | 210        |     | 35 |
| 58200-96400     |                     | 062207 | 9933013 |  | 992505 |        |        | 121        |     | 33 |
| 990C0-00830-17P |                     |        | 993517  |  | 992003 | 993043 | 993023 | 993203     | 204 | 37 |
| 990C0-00830-19P |                     |        | 993519  |  | 992004 | 993044 | 993024 | 993204     | 204 | 37 |
| 990C0-00830-21P |                     |        | 993521  |  | 992005 | 993045 | 993025 | 993205     | 204 | 37 |
| 990C0-00830-23P |                     |        | 993523  |  | 992006 | 993046 | 993026 | 993206     | 204 | 37 |
| 990C0-0083L-17P |                     |        |         |  |        |        | 993033 | 993213     | 204 | 37 |
| 990C0-0083L-19P |                     |        |         |  |        |        | 993034 | 993214     | 204 | 37 |
| 990C0-0083L-21P |                     |        |         |  |        |        | 993035 | 993215     | 204 | 37 |
| 990C0-0083L-23P |                     |        |         |  |        |        | 993036 | 993216     | 204 | 37 |
| 99105-00100-16P |                     | 061101 |         |  | 992113 | 993143 |        |            | 210 | 35 |
| 99105-00100-18P |                     | 061102 |         |  | 992114 | 993144 |        |            | 210 | 35 |
| 99105-00100-20P |                     | 061103 |         |  | 992115 | 993145 |        |            | 210 | 35 |
| 99105-00100-22P |                     | 061104 |         |  | 992116 | 993146 |        |            | 210 | 35 |

# MICHIGAN WHEEL OEM CROSS REFERENCE

| Original Equipment Manufacturer<br>Part & Trade Mark | Standard<br>Hub<br>Propeller | XHS® / XHS II® Hub Propeller |                  |                |                 |                    |                    | XHS® / XHS II®<br>Hub Kit(s) | Catalog Page #s |
|--|------------------------------|------------------------------|------------------|----------------|-----------------|--------------------|--------------------|------------------------------|-----------------|
|  | Michigan<br>Match®           | Ballistic®                   | Ballistic®<br>XL | Vortex®<br>XHS | Apollo®<br>Std. | Apollo®<br>Lg. Dia | Apollo®<br>4-Blade |                              |                 |

## SUZUKI® (Continued)

|                 |        |        |  |        |        |        |        |            |    |
|-----------------|--------|--------|--|--------|--------|--------|--------|------------|----|
| 99105-00101-20P | 061103 |        |  | 992115 | 993145 |        |        | 210        | 35 |
| 99105-00101-22P | 061104 |        |  | 992116 | 993146 |        |        | 210        | 35 |
| 99105-00103-18P | 061102 |        |  | 992114 | 993144 |        |        | 210        | 35 |
| 99105-00103-20P | 061103 |        |  | 992115 | 993145 |        |        | 210        | 35 |
| 99105-00103-22P | 061104 |        |  | 992116 | 993146 |        |        | 210        | 35 |
| 99105-00200-16P |        |        |  | 992002 | 993042 | 993022 |        | 204        | 34 |
| 99105-00200-18P |        |        |  | 992003 | 993043 | 993023 | 993203 | 204        | 34 |
| 99105-00200-20P |        | 933519 |  | 992004 | 993044 | 993024 | 993204 | 204        | 37 |
| 99105-00200-22P |        | 933521 |  | 992005 | 993045 | 993025 | 993205 | 204        | 37 |
| 99105-00200-24P |        | 933523 |  | 992006 | 993046 | 993026 | 993206 | 204        | 37 |
| 99105-00203-23P |        | 933523 |  | 992006 | 993046 | 993026 | 993206 | 204        | 37 |
| 99105-0020L-16P |        |        |  |        | 993052 | 993032 |        | 204        | 37 |
| 99105-0020L-18P |        | 937517 |  |        | 993053 | 993033 | 993213 | 204        | 37 |
| 99105-0020L-20P |        | 937519 |  |        | 993054 | 993034 | 993214 | 204        | 37 |
| 99105-0020L-22P |        | 937521 |  |        | 993055 | 993035 | 993215 | 204        | 37 |
| 99105-0020L-24P |        | 937523 |  |        | 993056 | 993036 | 993216 | 204        | 37 |
| 99105-00300-24P |        | 933523 |  | 992006 | 993046 | 993026 | 993206 | 204        | 37 |
| 99105-00400-23P |        | 933523 |  | 992006 | 993046 | 993026 | 993206 | 204        | 37 |
| 99105-00500-12P |        |        |  | 992604 | 993405 |        |        | 115        | 34 |
| 99105-00500-13P |        | 993213 |  | 992605 | 993406 |        |        | 115        | 34 |
| 99105-00500-14P |        |        |  | 992606 | 993407 |        |        | 115        | 34 |
| 99105-00500-15P |        | 933215 |  | 992408 | 993408 |        |        | 115        | 34 |
| 99105-00600-13P |        | 933013 |  |        |        |        |        | 121        | 33 |
| 99105-00600-15P |        | 933015 |  |        |        |        |        | 121        | 33 |
| 99105-00700-16P |        |        |  | 992114 | 993144 |        |        | See Note 4 | 36 |
| 99105-00700-18P |        |        |  | 992115 | 993145 |        |        | See Note 4 | 36 |
| 99105-00700-20P |        |        |  | 992116 | 993146 |        |        | See Note 4 | 36 |
| 99105-0070L-18P |        |        |  |        | 993155 |        |        | See Note 4 | 36 |
| 99105-0070L-20P |        |        |  |        | 993156 |        |        | See Note 4 | 36 |

## VOLVO®

|         |                          |        |        |        |        |        |        |     |    |
|---------|--------------------------|--------|--------|--------|--------|--------|--------|-----|----|
| 3587517 | SS 4-Blade Polished      |        |        | 992002 |        |        |        | 205 | 51 |
| 3587520 | SS 4-Blade Polished      |        |        | 992003 |        |        | 993203 | 205 | 51 |
| 3587521 | SS 4-Blade Polished (LH) |        |        |        |        |        | 993213 | 205 | 51 |
| 3587522 | SS 4-Blade Polished      |        |        | 992004 |        |        | 993204 | 205 | 51 |
| 3587523 | SS 4-Blade Polished (LH) |        |        |        |        |        | 993214 | 205 | 51 |
| 3587524 | SS 4-Blade Polished      |        |        | 992005 |        |        | 993205 | 205 | 51 |
| 3587525 | SS 4-Blade Polished (LH) |        |        |        |        |        | 993215 | 205 | 51 |
| 3587526 | SS 4-Blade Polished      |        |        | 992006 |        |        | 993206 | 205 | 51 |
| 3817466 | Aluminum 3-Blade         | 161001 |        | 992002 |        |        |        | 205 | 51 |
| 3817467 | Aluminum 3-Blade         | 161002 |        | 992003 |        |        |        | 205 | 51 |
| 3817468 | Aluminum 3-Blade         | 161003 |        | 992004 |        |        |        | 205 | 51 |
| 3817469 | Aluminum 3-Blade         | 161004 |        | 992005 |        |        |        | 205 | 51 |
| 3817470 | Aluminum 3-Blade         | 191005 |        | 992006 |        |        |        | 205 | 51 |
| 3840720 |                          |        |        | 992001 |        |        |        | 205 | 51 |
| 3850299 |                          | 161001 |        | 992002 | 993042 |        |        | 205 | 51 |
| 3850300 |                          | 161002 | 933517 | 992003 | 993043 | 993023 | 993203 | 205 | 51 |
| 3850301 |                          | 161003 | 933519 | 992004 | 993044 | 993024 | 993204 | 205 | 51 |
| 3850302 |                          | 161004 | 933521 | 992005 | 993045 | 993025 | 993205 | 205 | 51 |
| 3850303 |                          | 161005 | 933523 | 992006 | 993046 | 993026 | 993206 | 205 | 51 |
| 3850305 | SST®                     | 161001 | 933515 | 992002 | 993042 |        |        | 205 | 51 |
| 3850306 | SST®                     | 161002 | 933517 | 992003 | 993043 | 993023 | 993203 | 205 | 51 |
| 3850307 | SST®                     | 161002 | 933517 | 992003 | 993043 | 993023 | 993203 | 205 | 51 |
| 3850308 | SST®                     | 161003 | 933519 | 992004 | 993044 | 993024 | 993204 | 205 | 51 |
| 3850309 | SST®                     | 161004 | 933521 | 992005 | 993045 | 993025 | 993205 | 205 | 51 |
| 3850310 | SST®                     | 161005 | 933523 | 992006 | 993046 | 993026 | 993206 | 205 | 51 |
| 3850311 | VIPER™                   | 161002 | 933517 | 992003 | 993043 | 993023 | 993203 | 205 | 51 |
| 3850312 | VIPER™                   | 161003 | 933519 | 992004 | 993044 | 993024 | 993204 | 205 | 51 |
| 3850313 | VIPER™                   | 161004 | 933521 | 992005 | 993045 | 993025 | 993205 | 205 | 51 |
| 3850314 | VIPER™                   | 161005 | 933523 | 992006 | 993046 | 993026 | 993206 | 205 | 51 |
| 3850315 | SST® (LH)                |        |        |        | 993052 | 993032 |        | 205 | 51 |
| 3850316 | SST® (LH)                |        | 937517 |        | 993053 | 993033 | 993213 | 205 | 51 |
| 3850317 | SST® (LH)                |        | 937519 |        | 993054 | 993034 | 993214 | 205 | 51 |
| 3850318 | SST® (LH)                |        | 937521 |        | 993055 | 993035 | 993215 | 205 | 51 |
| 3850319 | SST® (LH)                |        | 937523 |        | 993056 | 993036 | 993216 | 205 | 51 |
| 3850320 | VIPER™ (LH)              |        | 937517 |        | 993053 | 993033 | 993213 | 205 | 51 |
| 3850321 | VIPER™ (LH)              |        | 937519 |        | 993054 | 993034 | 993214 | 205 | 51 |
| 3850322 | VIPER™ (LH)              |        | 937521 |        | 993055 | 993035 | 993215 | 205 | 51 |
| 3850323 | VIPER™ (LH)              |        | 937523 |        | 993056 | 993036 | 993216 | 205 | 51 |
| 3855142 | Raker®                   | 161003 | 933521 | 992004 | 993044 | 993024 | 993204 | 205 | 51 |
| 3855144 | Raker®                   | 161004 | 933523 | 992005 | 993045 | 993025 | 993205 | 205 | 51 |
| 3855146 | Raker®                   | 161005 | 346036 | 992006 | 993046 | 993026 | 993206 | 205 | 51 |
| 3855152 | Raker® (LH)              |        | 937521 |        | 993054 | 993034 | 993214 | 205 | 51 |
| 3855154 | Raker® (LH)              |        | 937523 |        | 993055 | 993035 | 993215 | 205 | 51 |

\* Indicates limited quantities.

# MICHIGAN WHEEL OEM CROSS REFERENCE

| Original Equipment Manufacturer<br>Part & Trade Mark | Standard<br>Hub<br>Propeller | XHS® / XHS II® Hub Propeller |                  |                |                 |                    |                    | XHS® / XHS II®<br>Hub Kit(s) | Catalog Page #s |
|--|------------------------------|------------------------------|------------------|----------------|-----------------|--------------------|--------------------|------------------------------|-----------------|
|  | Michigan<br>Match®           | Ballistic®                   | Ballistic®<br>XL | Vortex®<br>XHS | Apollo®<br>Std. | Apollo®<br>Lg. Dia | Apollo®<br>4-Blade |                              |                 |

### VOLVO® (Continued)

|           |                          |        |  |        |  |        |  |        |        |        |     |    |
|-----------|--------------------------|--------|--|--------|--|--------|--|--------|--------|--------|-----|----|
| 3855156   | Raker® (LH)              |        |  |        |  |        |  | 993056 | 993036 | 993216 | 205 | 51 |
| 3855481   |                          |        |  | 937519 |  |        |  | 993054 |        |        | 205 | 51 |
| 3860708   | SS 3-Blade Polished      | 161003 |  | 933519 |  | 992004 |  | 993044 | 993024 | 993204 | 205 | 51 |
| 3860709   | SS 3-Blade Polished      | 161004 |  | 933521 |  | 992005 |  | 993045 | 993025 | 993205 | 205 | 51 |
| 3860714   | SS 3-Blade Polished (LH) |        |  | 937517 |  |        |  | 993053 | 993033 | 993213 | 205 | 51 |
| 3860715   | SS 3-Blade Polished (LH) |        |  | 937519 |  |        |  | 993054 | 993034 | 993214 | 205 | 51 |
| 3860716   | SS 3-Blade Polished (LH) |        |  | 937521 |  |        |  | 993055 | 993035 | 993215 | 205 | 51 |
| 3860717   | SS 3-Blade Polished (LH) |        |  | 937523 |  |        |  | 993056 | 993036 | 993216 | 205 | 51 |
| 3862462   | SS 3-Blade Polished      | 161002 |  | 933517 |  | 992003 |  | 993043 | 993023 | 993203 | 205 | 51 |
| 3870710   | SS 3-Blade Polished      | 161005 |  | 933523 |  | 992006 |  | 993046 | 993026 | 993206 | 205 | 51 |
| 3850298-5 |                          | 161002 |  | 933517 |  | 992003 |  | 993043 | 993023 | 993203 | 205 | 51 |
| 3850299-3 |                          | 161001 |  | 933515 |  | 992002 |  | 993042 |        |        | 205 | 51 |
| 3850300-9 |                          | 161002 |  | 933517 |  | 992003 |  | 993043 | 993023 | 993203 | 205 | 51 |
| 3850301-7 |                          | 161003 |  | 933519 |  | 992004 |  | 993044 | 993024 | 993204 | 205 | 51 |
| 3850302-5 |                          | 161004 |  | 933521 |  | 992005 |  | 993045 | 993025 | 993205 | 205 | 51 |
| 3850303-3 |                          | 161005 |  | 933523 |  | 992006 |  | 993046 | 993026 | 993206 | 205 | 51 |
| 3850305-8 | SS Black                 | 161001 |  | 933515 |  |        |  | 993042 |        |        | 205 | 51 |
| 3850307-4 | SS Black                 | 161002 |  | 933517 |  |        |  | 993043 | 993023 | 993203 | 205 | 51 |
| 3850308-2 | SS Black                 | 161003 |  | 933519 |  |        |  | 993044 | 993024 | 993204 | 205 | 51 |
| 3850309-0 | SS Black                 | 161004 |  | 933521 |  |        |  | 993045 | 993025 | 993205 | 205 | 51 |
| 3850310-8 | SS Black                 | 161005 |  | 933523 |  |        |  | 993046 | 993026 | 993206 | 205 | 51 |
| 3850311-6 | SS 3-Blade Polished      | 161002 |  | 933517 |  |        |  | 993043 | 993023 | 993203 | 205 | 51 |
| 3850312-4 | SS 3-Blade Polished      | 161003 |  | 933519 |  |        |  | 993044 | 993024 | 993204 | 205 | 51 |
| 3850313-2 | SS 3-Blade Polished      | 161005 |  | 933523 |  |        |  | 993046 | 993026 | 993206 | 205 | 51 |
| 3850314-0 | SS 3-Blade Polished      | 161004 |  | 933521 |  |        |  | 993045 | 993025 | 993205 | 205 | 51 |
| 3850315-7 | SS Black (LH)            |        |  |        |  |        |  | 993052 | 993032 |        | 205 | 51 |
| 3850316-5 | SS Black (LH)            |        |  | 937517 |  |        |  | 993053 | 993033 | 993213 | 205 | 51 |
| 3850317-3 | SS Black (LH)            |        |  | 937519 |  |        |  | 993054 | 993034 | 993214 | 205 | 51 |
| 3850318-1 | SS Black (LH)            |        |  | 937521 |  |        |  | 993055 | 993035 | 993215 | 205 | 51 |
| 3850319-9 | SS Black (LH)            |        |  | 937523 |  |        |  | 993056 | 993036 | 993216 | 205 | 51 |
| 3850320-7 | SS 3-Blade Polished (LH) |        |  | 937517 |  |        |  | 993053 |        |        | 205 | 51 |
| 3850321-5 | SS 3-Blade Polished (LH) |        |  | 937519 |  |        |  | 993054 | 993034 | 993214 | 205 | 51 |
| 3850322-3 | SS 3-Blade Polished (LH) |        |  | 937523 |  |        |  | 993056 | 993036 | 993216 | 205 | 51 |
| 3850323-1 | SS 3-Blade Polished (LH) |        |  | 937521 |  |        |  | 993055 | 993035 | 993215 | 205 | 51 |
| 3855480-4 |                          |        |  |        |  |        |  |        | 993033 |        | 205 | 51 |
| 3855481-2 |                          |        |  |        |  |        |  |        | 993034 |        | 205 | 51 |
| 3858026-2 | SS 3-Blade Polished      | 161002 |  | 933517 |  | 992003 |  | 993043 | 993023 | 993203 | 205 | 51 |
| 3858027-0 | SS 3-Blade Polished      | 161003 |  | 933519 |  | 992004 |  | 993044 | 993024 | 993204 | 205 | 51 |
| 3858028-8 | SS 3-Blade Polished      | 161004 |  | 933521 |  | 992005 |  | 993045 | 993025 | 993205 | 205 | 51 |
| 3858029-6 | SS 3-Blade Polished (LH) |        |  | 937517 |  |        |  | 993053 | 993033 | 993213 | 205 | 51 |
| 3858030-4 | SS 3-Blade Polished (LH) |        |  | 937519 |  |        |  | 993054 | 993034 | 993214 | 205 | 51 |
| 3858031-2 | SS 3-Blade Polished (LH) |        |  | 937521 |  |        |  | 993055 | 993035 | 993215 | 205 | 51 |

### YAMAHA®

|                     |                         |        |  |        |  |        |  |        |        |        |            |       |
|---------------------|-------------------------|--------|--|--------|--|--------|--|--------|--------|--------|------------|-------|
| 61A-45972-00-98     | Black Steel             |        |  | 933521 |  |        |  | 993045 | 993025 | 993205 | 203        | 42,52 |
| 61A-45974-00-98     | Black Steel             |        |  | 933519 |  |        |  | 993044 | 993024 | 993204 | 203        | 42,52 |
| 61A-45978-00-98     | Black Steel             |        |  | 933517 |  |        |  | 993043 | 993023 | 993203 | 203        | 42,52 |
| 61B-45972-00-98     | Black Steel (LH)        |        |  | 937521 |  |        |  | 993055 | 993035 | 993215 | 203        | 42,52 |
| 61B-45974-00-98     | Black Steel (LH)        |        |  | 937519 |  |        |  | 993054 | 993034 | 993214 | 203        | 42,52 |
| 61B-45978-00-98     | Black Steel (LH)        |        |  | 937517 |  |        |  | 993053 | 993033 | 993213 | 203        | 42,52 |
| 62A-45970-10-00     | Pro Series™             |        |  | 335934 |  |        |  | 993145 |        |        | See Note 1 | 41    |
| 62A-45970-10-00 PRO | Pro Series™ HP          |        |  |        |  |        |  | 993146 |        |        | See Note 1 | 41    |
| 62A-45972-10-00     | Pro Series™             |        |  | 335935 |  |        |  | 993146 |        |        | See Note 1 | 41    |
| 62A-45974-10-00 PRO | Pro Series™ HP          |        |  | 933419 |  |        |  | 993145 |        |        | See Note 1 | 41    |
| 63V-45947-00-EL     |                         | 102003 |  |        |  |        |  |        |        |        |            | 38    |
| 63V-45945-10-EL     |                         | 102004 |  |        |  |        |  |        |        |        |            | 38    |
| 650-45943-01-36     |                         | 012102 |  |        |  |        |  |        |        |        |            | 38    |
| 651-45947-00-36     |                         | 012011 |  |        |  |        |  |        |        |        |            | 38    |
| 653-45941-01-36     |                         | 012013 |  |        |  |        |  |        |        |        |            | 38    |
| 663-45930-00-00     | Painted Stainless Steel |        |  |        |  |        |  | 993407 |        |        | 117        | 40    |
| 663-45943-01-36     |                         | 032040 |  |        |  | 992408 |  | 993408 |        |        | 117        | 40    |
| 663-45943-02-36     |                         | 032040 |  |        |  | 992408 |  | 993408 |        |        | 117        | 40    |
| 663-45943-02-EL     |                         | 032040 |  |        |  | 992408 |  | 993408 |        |        | 117        | 40    |
| 663-45945-00-EL     |                         | 032042 |  |        |  | 992605 |  | 993406 |        |        | 117        | 40    |
| 663-45945-01-36     |                         | 032042 |  |        |  | 992605 |  | 992406 |        |        | 117        | 40    |
| 663-45945-02-36     |                         | 032042 |  |        |  | 992605 |  | 993406 |        |        | 117        | 40    |
| 663-45945-02-EL     |                         | 032042 |  |        |  | 992605 |  | 993406 |        |        | 117        | 40    |
| 663-45947-01-36     |                         | 032044 |  |        |  | 992603 |  |        |        |        | 117        | 40    |
| 63-45947-02-36      |                         | 032044 |  |        |  | 992603 |  |        |        |        | 117        | 40    |
| 663-45947-02-EL     |                         | 032044 |  |        |  | 992603 |  |        |        |        | 117        | 40    |
| 663-45949-01-36     |                         |        |  |        |  | 992409 |  |        |        |        | 117        | 40    |

# MICHIGAN WHEEL OEM CROSS REFERENCE

| Original Equipment Manufacturer<br>Part & Trade Mark | Standard<br>Hub<br>Propeller | XHS® / XHS II® Hub Propeller |                  |                |                 |                    |                    | XHS® / XHS II®<br>Hub Kit(s) | Catalog Page #s |
|--|------------------------------|------------------------------|------------------|----------------|-----------------|--------------------|--------------------|------------------------------|-----------------|
|  | Michigan<br>Match®           | Ballistic®                   | Ballistic®<br>XL | Vortex®<br>XHS | Apollo®<br>Std. | Apollo®<br>Lg. Dia | Apollo®<br>4-Blade |                              |                 |

## YAMAHA® (Continued)

|                       |                           |             |             |             |             |             |                 |          |       |
|-----------------------|---------------------------|-------------|-------------|-------------|-------------|-------------|-----------------|----------|-------|
| 663-45952-01-EL.....  |                           |             |             | 992409..... |             |             |                 | 117..... | 40    |
| 663-45952-02-EL.....  | 032043.....               |             |             | 992604..... | 993405..... |             |                 | 117..... | 40    |
| 663-45956-01-00.....  | 032046.....               |             |             | 992601..... |             |             |                 | 117..... | 40    |
| 6663-45956-01-EL..... | 032046.....               |             |             | 992601..... |             |             |                 | 117..... | 40    |
| 663-45958-00-36.....  | 032041.....               |             |             | 992606..... | 993407..... |             |                 | 117..... | 40    |
| 663-45958-00-EL.....  | 032041.....               |             |             | 992606..... | 993407..... |             |                 | 117..... | 40    |
| 663-45958-01-36.....  | 032041.....               |             |             | 992606..... | 993407..... |             |                 | 117..... | 40    |
| 663-45958-01-EL.....  | 032041.....               |             |             | 992606..... | 993407..... |             |                 | 117..... | 40    |
| 663-45976-00-00.....  | Painted Stainless Steel   |             |             | 993408..... |             |             |                 | 117..... | 40    |
| 664-45941-01-36.....  | 022001.....               |             |             | 992501..... |             |             |                 | 123..... | 39    |
| 664-45941-01-00.....  | 022001.....               |             |             | 992501..... |             |             |                 | 123..... | 39    |
| 664-45941-01-EL.....  | 022001.....               |             |             | 992501..... |             |             |                 | 123..... | 39    |
| 664-45945-00-36.....  | 022002.....               |             |             |             |             |             |                 |          | 39    |
| 664-45945-00-00.....  | 022002.....               |             |             |             |             |             |                 |          | 39    |
| 664-45945-00-EL.....  | 022002.....               |             |             |             |             |             |                 |          | 39    |
| 664-45949-02-00.....  |                           | 933013..... |             | 992505..... |             |             |                 | 123..... | 39    |
| 664-45949-02-EL.....  |                           | 933013..... |             | 992505..... |             |             |                 | 123..... | 39    |
| 664-45952-00-00.....  |                           |             |             | 992506..... |             |             |                 | 123..... | 39    |
| 664-45952-00-EL.....  |                           |             |             | 992506..... |             |             |                 | 123..... | 39    |
| 664-45954-00-EL.....  | 022003.....               |             |             | 992504..... |             |             |                 | 123..... | 39    |
| 664-45954-01-EL.....  | 022003.....               |             |             | 992504..... |             |             |                 | 123..... | 39    |
| 664-45947-01-00.....  | 022004.....               |             |             |             |             |             |                 |          | 39    |
| 664-45949-02-00.....  | 022005.....               |             |             |             |             |             |                 |          | 39    |
| 664-45952-00-00.....  | 022006.....               |             |             |             |             |             |                 |          | 39    |
| 664-45970-00-98.....  | Painted Stainless Steel   | 933013..... |             | 992505..... |             |             |                 | 123..... | 39    |
| 66K-45972-B0-00.....  | Pro Series™               |             | 953526..... |             |             |             |                 | 203..... | 42,52 |
| 66K-45974-B0-00.....  | Pro Series™               |             | 953524..... |             | 993046..... |             |                 | 203..... | 42,52 |
| 683-45941-00-00.....  | 102107.....               |             |             |             |             |             |                 |          | 38    |
| 683-45943-00-36.....  | 102005.....               |             |             |             |             |             |                 |          | 38    |
| 683-45943-00-EL.....  | 102005.....               |             |             |             |             |             |                 |          | 38    |
| 683-45945-00-36.....  | 102004.....               |             |             |             |             |             |                 |          | 38    |
| 683-45945-00-EL.....  | 102004.....               |             |             |             |             |             |                 |          | 38    |
| 683-45947-00-36.....  | 102003.....               |             |             |             |             |             |                 |          | 38    |
| 683-45947-00-EL.....  | 102003.....               |             |             |             |             |             |                 |          | 38    |
| 683-45952-00-00.....  | 102106.....               |             |             |             |             |             |                 |          | 38    |
| 683-W4591-02-EL.....  | 102003.....               |             |             |             |             |             |                 |          | 38    |
| 68F-45970-00-00.....  | Reliance®                 | 933515..... |             | 992002..... | 993042..... |             |                 | 203..... | 42,52 |
| 68F-45972-00-00.....  | Reliance®                 | 101027..... | 933517..... | 992003..... | 993043..... | 993023..... | 993203.....     | 203..... | 42,52 |
| 68F-45974-00-00.....  | Reliance®                 | 101028..... | 933519..... | 992004..... | 993044..... | 993024..... | 993204.....     | 203..... | 42,52 |
| 68F-45976-00-00.....  | Reliance®                 |             | 933521..... | 992005..... | 993045..... | 993025..... | 993205.....     | 203..... | 42,52 |
| 68G-45972-00-00.....  | Reliance® (LH)            |             | 937517..... |             | 993053..... | 993033..... | 993213.....     | 203..... | 42,52 |
| 68G-45974-00-00.....  | Reliance® (LH)            |             | 937519..... |             | 993054..... | 993034..... | 993214.....     | 203..... | 42,52 |
| 68G-45976-00-00.....  | Reliance® (LH)            |             | 937521..... |             | 993055..... | 993035..... | 993215.....     | 203..... | 42,52 |
| 68U-45941-00-EL.....  | 032046.....               |             |             | 992402..... |             |             |                 | 117..... | 40    |
| 69L-45974-20-00.....  | V MAX®                    |             |             | 992006..... | 993046..... | 993026..... | 993206.....     | 203..... | 42,52 |
| 69W-45943-00-00.....  | 032040.....               | 933215..... |             |             | 993408..... |             |                 | 117..... | 40    |
| 69W-45943-00-EL.....  | 032040.....               | 933215..... |             |             | 993408..... |             |                 | 117..... | 40    |
| 69W-45945-00-00.....  | 032042.....               | 993213..... |             | 992605..... | 993406..... |             |                 | 117..... | 40    |
| 69W-45945-00-EL.....  | 032042.....               | 993213..... |             | 992605..... | 993406..... |             |                 | 117..... | 40    |
| 69W-45947-00-00.....  | 032044.....               |             |             | 992603..... |             |             |                 | 117..... | 40    |
| 69W-45947-00-EL.....  | 032044.....               |             |             | 992603..... |             |             |                 | 117..... | 40    |
| 69W-45952-00-00.....  | 032043.....               |             |             | 992604..... | 993405..... |             |                 | 117..... | 40    |
| 69W-45958-00-00.....  | 032041.....               |             |             | 992606..... | 993407..... |             |                 | 117..... | 40    |
| 69W-45958-01-00.....  | 032041.....               |             |             | 992606..... | 993407..... |             |                 | 117..... | 40    |
| 6CB-45974-00-00.....  | V MAX® Ventless           |             | 933523..... |             |             |             |                 | 203..... | 42    |
| 6D0-45970-00-00.....  | Saltwater Series II™      | 101028..... | 933519..... | 992004..... | 993044..... | 993024..... | 993204.....     | 203..... | 42,52 |
| 6D0-45972-00-00.....  | Saltwater Series II™      |             | 933521..... | 992005..... | 993045..... | 993025..... | 993205.....     | 203..... | 42,52 |
| 6D0-45978-00-00.....  | Saltwater Series II™      | 101027..... | 933517..... | 992003..... | 993043..... | 993023..... | 993203.....     | 203..... | 42,52 |
| 6D1-45970-00-00.....  | Saltwater Series II™ (LH) |             | 937519..... |             | 993054..... | 993034..... | 993214.....     | 203..... | 42,52 |
| 6D1-45972-00-00.....  | Saltwater Series II™ (LH) |             | 937521..... |             | 993055..... | 993035..... | 993215.....     | 203..... | 42,52 |
| 6D1-45978-00-00.....  | Saltwater Series II™ (LH) |             | 937517..... |             | 993053..... | 993033..... | 993213.....     | 203..... | 42,52 |
| 6E0-45941-01-00.....  | 102018.....               |             |             |             |             |             |                 |          | 38    |
| 6E0-45943-01-00.....  | 102017.....               |             |             |             |             |             |                 |          | 38    |
| 6E5-45941-00-00.....  | 101034.....               | 933419..... |             | 992115..... | 993145..... |             | See Note 1..... |          | 41    |
| 6E5-45941-00-36.....  | 101034.....               | 933419..... |             | 992115..... | 993145..... |             | See Note 1..... |          | 41    |
| 6E5-45941-00-EL.....  | 101034.....               | 933419..... |             | 992115..... | 993145..... |             | See Note 1..... |          | 41    |
| 6E5-45943-00-00.....  | 101135.....               | 933421..... |             | 992116..... | 993146..... |             | See Note 1..... |          | 41    |
| 6E5-45943-00-36.....  | 101135.....               | 933421..... |             | 992116..... | 993146..... |             | See Note 1..... |          | 41    |
| 6E5-45943-00-EL.....  | 101135.....               | 933421..... |             | 992116..... | 993146..... |             | See Note 1..... |          | 41    |
| 6E5-45945-00-36.....  | 101033.....               | 933417..... |             | 992114..... | 993144..... |             | See Note 1..... |          | 41    |
| 6E5-45945-00-EL.....  | 101033.....               | 933417..... |             | 992114..... | 993144..... |             | See Note 1..... |          | 41    |
| 6E5-45945-01-00.....  | 101033.....               | 933417..... |             | 992114..... | 993144..... |             | See Note 1..... |          | 41    |
| 6E5-45945-01-EL.....  | 101033.....               | 933417..... |             | 992114..... | 993144..... |             | See Note 1..... |          | 41    |

# MICHIGAN WHEEL OEM CROSS REFERENCE

| Original Equipment Manufacturer<br>Part & Trade Mark | Standard<br>Hub<br>Propeller | XHS® / XHS II® Hub Propeller |                  |                |                 |                    |                    | XHS® / XHS II®<br>Hub Kit(s) | Catalog Page #s |
|--|------------------------------|------------------------------|------------------|----------------|-----------------|--------------------|--------------------|------------------------------|-----------------|
|  | Michigan<br>Match®           | Ballistic®                   | Ballistic®<br>XL | Vortex®<br>XHS | Apollo®<br>Std. | Apollo®<br>Lg. Dia | Apollo®<br>4-Blade |                              |                 |

## 6 YAMAHA® (Continued)

|                 |                              |        |        |        |        |        |        |            |       |
|-----------------|------------------------------|--------|--------|--------|--------|--------|--------|------------|-------|
| E5-45947-00-00  | 101032                       | 933415 |        | 992113 | 993143 |        |        | See Note 1 | 41    |
| 6E5-45947-00-36 | 101032                       | 933415 |        | 992113 | 993143 |        |        | See Note 1 | 41    |
| 6E5-45947-00-EL | 101032                       | 933415 |        | 992113 | 993143 |        |        | See Note 1 | 41    |
| 6E5-45949-00-00 | 101031                       |        |        | 992112 |        |        |        | See Note 1 | 41    |
| 6E5-45949-00-36 | 101031                       |        |        | 992112 |        |        |        | See Note 1 | 41    |
| 6E5-45949-00-EL | 101031                       |        |        | 992112 |        |        |        | See Note 1 | 41    |
| 6E5-45954-00-00 | 101036                       |        |        | 992111 |        |        |        | See Note 1 | 41    |
| 6E5-45954-00-EL | 101036                       |        |        | 992111 |        |        |        | See Note 1 | 41    |
| 6E5-45970-10-00 | 101028                       | 933519 |        | 992004 | 993044 | 993024 | 993204 | 203        | 42,52 |
| 6E5-45970-10-98 | 101028                       | 933519 |        | 992004 | 993044 | 993024 | 993204 | 203        | 42,52 |
| 6E5-45972-10-00 |                              | 933523 |        | 992006 | 993046 | 993026 | 993206 | 203        | 42,52 |
| 6E5-45972-10-98 |                              | 933523 |        | 992006 | 993046 | 993026 | 993206 | 203        | 42,52 |
| 6E5-45976-10-00 | 101029                       | 933521 |        | 992005 | 993045 | 993025 | 993205 | 203        | 42,52 |
| 6E5-45976-10-98 | 101029                       | 933521 |        | 992005 | 993045 | 993025 | 993205 | 203        | 42,52 |
| 6E5-45978-10-00 |                              | 933525 |        |        |        |        |        | 203        | 42,52 |
| 6E5-45978-10-98 |                              | 933525 |        |        |        |        |        | 203        | 42,52 |
| 6G1-45943-00-00 | 102002                       |        |        |        |        |        |        |            | 38    |
| 6G1-45943-00-36 | 102002                       |        |        |        |        |        |        |            | 38    |
| 6G1-45943-00-EL | 102002                       |        |        |        |        |        |        |            | 38    |
| 6G5-45930-00-98 |                              | 933525 |        |        |        |        |        | 203        | 42,52 |
| 6G5-45941-00-00 | 101025                       | 933515 |        | 992002 | 993042 | 993022 |        | 203        | 42,52 |
| 6G5-45941-00-36 | 101025                       | 933515 |        | 992002 | 993042 | 993022 |        | 203        | 42,52 |
| 6G5-45941-00-98 | 101025                       | 933515 |        | 992002 | 993042 | 993022 |        | 203        | 42,52 |
| 6G5-45941-00-EL | 101025                       | 933515 |        | 992002 | 993042 | 993022 |        | 203        | 42,52 |
| 6G5-45943-00-36 | 101029                       | 933521 |        | 992005 | 993045 | 993025 | 993205 | 203        | 42,52 |
| 6G5-45943-00-EL | 101029                       | 933521 |        | 992005 | 993045 | 993025 | 993205 | 203        | 42,52 |
| 6G5-45943-01-00 | 101029                       | 933521 |        | 992005 | 993045 | 993025 | 993205 | 203        | 42,52 |
| 6G5-45943-01-98 | 101029                       | 933521 |        | 992005 | 993045 | 993025 | 993205 | 203        | 42,52 |
| 6G5-45945-00-36 | 101028                       | 933519 |        | 992004 | 993044 | 993024 | 993204 | 203        | 42,52 |
| 6G5-45945-00-EL | 101028                       | 933519 |        | 992004 | 993044 | 993024 | 993204 | 203        | 42,52 |
| 6G5-45945-01-00 | 101028                       | 933519 |        | 992004 | 993044 | 993024 | 993204 | 203        | 42,52 |
| 6G5-45945-01-98 | 101028                       | 933519 |        | 992004 | 993044 | 993024 | 993204 | 203        | 42,52 |
| 6G5-45945-01-EL | 101028                       | 933519 |        | 992004 | 993044 | 993024 | 993204 | 203        | 42,52 |
| 6G5-45947-01-00 | 101027                       | 933517 |        | 992003 | 993043 | 993023 | 993203 | 203        | 42,52 |
| 6G5-45947-01-98 | 101027                       | 933517 |        | 992003 | 993043 | 993023 | 993203 | 203        | 42,52 |
| 6G5-45947-01-EL | 101027                       | 933517 |        | 992003 | 993043 | 993023 | 993203 | 203        | 42,52 |
| 6G5-45949-00-36 |                              | 933523 |        | 992006 | 993046 | 993026 | 993206 | 203        | 42,52 |
| 6G5-45949-00-98 |                              | 933523 |        | 992006 | 993046 | 993026 | 993206 | 203        | 42,52 |
| 6G5-45949-00-EL |                              | 933523 |        | 992006 | 993046 | 993026 | 993206 | 203        | 42,52 |
| 6G5-45970-00-98 | 101025                       | 933515 |        | 992002 | 993042 |        |        | 203        | 42,52 |
| 6G5-45970-01-98 | 101025                       | 933515 |        | 992002 | 993042 |        |        | 203        | 42,52 |
| 6G5-45970-02-98 | 101025                       | 933515 |        | 992002 | 993042 |        |        | 203        | 42,52 |
| 6G5-45972-00-98 | Painted Stainless Steel      | 101029 | 933521 | 992005 | 993045 | 993025 | 993205 | 203        | 42,52 |
| 6G5-45972-01-98 | Painted Stainless Steel      | 101029 | 933521 | 992005 | 993045 | 993025 | 993205 | 203        | 42,52 |
| 6G5-45972-02-98 | Painted Stainless Steel      | 101029 | 933521 | 992005 | 993045 | 993025 | 993205 | 203        | 42,52 |
| 6G5-45972-03-98 | Painted Stainless Steel      | 101029 | 933521 | 992005 | 993045 | 993025 | 993205 | 203        | 42,52 |
| 6G5-45974-00-98 | Painted Stainless Steel      | 101028 | 933519 | 992004 | 993044 | 993024 | 993204 | 203        | 42,52 |
| 6G5-45974-01-98 | Painted Stainless Steel      | 101028 | 933519 | 992004 | 993044 | 993024 | 993204 | 203        | 42,52 |
| 6G5-45974-02-98 | Painted Stainless Steel      | 101028 | 933519 | 992004 | 993044 | 993024 | 993204 | 203        | 42,52 |
| 6G5-45974-03-98 | Painted Stainless Steel      | 101028 | 933519 | 992004 | 993044 | 993024 | 993204 | 203        | 42,52 |
| 6G5-45976-00-98 | Painted Stainless Steel      | 101029 | 933523 | 992005 | 993046 | 993026 | 993206 | 203        | 42,52 |
| 6G5-45976-01-98 | Painted Stainless Steel      | 101029 | 933523 | 992005 | 993046 | 993026 | 993206 | 203        | 42,52 |
| 6G5-45978-00-98 | Painted Stainless Steel      | 101027 | 933517 | 992003 | 993043 | 993023 | 993203 | 203        | 42,52 |
| 6G5-45978-01-98 | Painted Stainless Steel      | 101027 | 933517 | 992003 | 993043 | 993023 | 993203 | 203        | 42,52 |
| 6G5-45978-02-98 | Painted Stainless Steel      | 101027 | 933517 | 992003 | 993043 | 993023 | 993203 | 203        | 42,52 |
| 6G5-45978-03-98 | Painted Stainless Steel      | 101027 | 933517 | 992003 | 993043 | 993023 | 993203 | 203        | 42,52 |
| 6H5-45952-00-00 | 031074                       |        |        |        |        |        |        |            | 40    |
| 6H5-45943-00-00 |                              |        |        | 992408 |        |        |        | 117        | 40    |
| 6H5-45943-00-EL |                              |        |        | 992408 |        |        |        | 117        | 40    |
| 6H5-45945-00-00 | 031075                       |        |        |        |        |        |        |            | 40    |
| 6H5-45945-00-EL |                              |        |        | 992406 |        |        |        | 117        | 40    |
| 6H5-45952-00-00 |                              |        |        | 992405 |        |        |        | 117        | 40    |
| 6H5-45952-00-EL |                              |        |        | 992405 |        |        |        | 117        | 40    |
| 6H5-45958-00-00 | 031076                       |        |        |        |        |        |        |            | 40    |
| 6H5-45958-00-EL |                              |        |        | 992407 |        |        |        | 117        | 40    |
| 6J9-45972-B0-00 | Pro Series™                  |        | 953524 |        | 993046 | 993026 | 993206 | 203        | 42,52 |
| 6J9-45976-10-00 | Pro Series™                  |        | 953522 |        | 993045 | 993025 | 993205 | 203        | 42,52 |
| 6K1-45945-00-98 |                              | 937519 |        |        | 993054 | 993032 | 993214 | 203        | 42,52 |
| 6K1-45947-00-98 |                              | 937517 |        |        | 993053 | 993033 | 993213 | 203        | 42,52 |
| 6K1-45970-00-98 |                              |        |        |        | 993052 | 993022 |        | 203        | 42,52 |
| 6K1-45970-01-98 | Painted Stainless Steel (LH) |        |        |        | 993052 | 993022 |        | 203        | 42,52 |
| 6K1-45972-00-00 | Painted Stainless Steel (LH) |        | 937521 |        | 993055 | 993035 | 993215 | 203        | 42,52 |
| 6K1-45972-00-98 | Painted Stainless Steel (LH) |        | 937521 |        | 993055 | 993035 | 993215 | 203        | 42,52 |

# MICHIGAN WHEEL OEM CROSS REFERENCE

| Original Equipment Manufacturer<br>Part & Trade Mark | Standard<br>Hub<br>Propeller | XHS® / XHS II® Hub Propeller |                  |                |                 |                    | XHS® / XHS II®<br>Hub Kit(s) | Catalog Page #s |
|--|------------------------------|------------------------------|------------------|----------------|-----------------|--------------------|------------------------------|-----------------|
|  | Michigan<br>Match®           | Ballistic®                   | Ballistic®<br>XL | Vortex®<br>XHS | Apollo®<br>Std. | Apollo®<br>Lg. Dia |                              |                 |

## YAMAHA® (Continued)

|                 |                              |        |        |        |        |        |        |        |            |       |
|-----------------|------------------------------|--------|--------|--------|--------|--------|--------|--------|------------|-------|
| 6K1-45972-01-98 | Painted Stainless Steel (LH) | 937521 |        |        |        | 993055 | 993035 | 993215 | 203        | 42,52 |
| 6K1-45974-00-00 | Painted Stainless Steel (LH) | 937519 |        |        |        | 993054 | 993034 | 993214 | 203        | 42,52 |
| 6K1-45974-01-98 | Painted Stainless Steel (LH) | 937519 |        |        |        | 993054 | 993034 | 993214 | 203        | 42,52 |
| 6K1-45974-02-98 | Painted Stainless Steel (LH) | 937519 |        |        |        | 993054 | 993034 | 993214 | 203        | 42,52 |
| 6K1-45976-00-98 | Painted Stainless Steel (LH) | 937523 |        |        |        | 993056 | 993036 | 993216 | 203        | 42,52 |
| 6K1-45978-01-98 | Painted Stainless Steel (LH) | 937523 |        |        |        | 993056 | 993036 | 993216 | 203        | 42,52 |
| 6K1-45978-00-00 | Painted Stainless Steel (LH) | 937517 |        |        |        | 993053 | 993033 | 993213 | 203        | 42,52 |
| 6K1-45978-00-98 | Painted Stainless Steel (LH) | 937517 |        |        |        | 993053 | 993033 | 993213 | 203        | 42,52 |
| 6K1-45978-01-98 | Painted Stainless Steel (LH) | 937517 |        |        |        | 993053 | 993033 | 993213 | 203        | 42,52 |
| 6R4-45970-AO-00 | Saltwater Series™            | 101028 | 933519 |        | 992004 | 993044 | 993024 | 993214 | 203        | 42,52 |
| 6R4-45972-AO-00 | Saltwater Series™            | 101029 | 933521 |        | 992005 | 993045 | 993025 | 993215 | 203        | 42,52 |
| 6R4-45974-AO-00 | Saltwater Series™            |        | 933523 |        | 992006 | 993046 | 993026 | 993206 | 203        | 42,52 |
| 6R4-45976-AO-00 | Saltwater Series™            |        | 933523 |        | 992006 | 993046 | 993026 | 993206 | 203        | 42,52 |
| 6R4-45978-AO-00 | Saltwater Series™            | 101027 |        |        | 992003 | 993043 | 993023 | 993203 | 203        | 42,52 |
| MAR-GYT3B-02-13 | Performance 3-Blade          |        | 933013 |        |        |        |        |        | 117        | 40    |
| MAR-GYT3B-03-12 | Performance 3-Blade          | 032043 |        |        | 992604 | 993405 |        |        | 117        | 40    |
| MAR-GYT3B-03-13 | Performance 3-Blade          | 032042 | 993213 |        | 992605 | 993406 |        |        | 117        | 40    |
| MAR-GYT3B-03-14 | Performance 3-Blade          | 032041 |        |        | 992606 | 993407 |        |        | 117        | 40    |
| MAR-GYT3B-03-15 | Performance 3-Blade          | 032040 | 933215 |        | 992408 | 993408 |        |        | 117        | 40    |
| MAR-GYT3B-V4-14 | Performance 3-Blade          |        | 933415 |        |        |        |        |        | See Note 1 | 41    |
| MAR-GYT3B-V4-16 | Performance 3-Blade          | 101032 | 933417 |        | 992113 | 993143 |        |        | See Note 1 | 41    |
| MAR-GYT3B-V4-18 | Performance 3-Blade          | 101033 | 933419 |        | 992114 | 993144 |        |        | See Note 1 | 41    |
| MAR-GYT3B-V4-20 | Performance 3-Blade          | 101034 | 933421 |        | 992115 | 993145 |        |        | See Note 1 | 41    |
| MAR-GYT3B-V4-22 | Performance 3-Blade          | 101135 |        |        | 992116 | 993146 |        |        | See Note 1 | 41    |
| MAR-GYT3B-V6-16 | Performance 3-Blade          |        | 933517 |        | 992002 | 993042 |        |        | 203        | 42,52 |
| MAR-GYT3B-V6-18 | Performance 3-Blade          | 101027 | 933519 |        | 992003 | 993043 | 993023 | 993203 | 203        | 42,52 |
| MAR-GYT3B-V6-20 | Performance 3-Blade          | 101028 | 933521 |        | 992004 | 993044 | 993024 | 993204 | 203        | 42,52 |
| MAR-GYT3B-V6-22 | Performance 3-Blade          | 101029 | 933523 |        | 992005 | 993045 | 993025 | 993205 | 203        | 42,52 |
| MAR-GYT3B-V6-24 | Performance 3-Blade          |        | 933525 |        | 992006 | 993046 | 993026 | 993206 | 203        | 42,52 |
| MAR-GYT3B-XL-23 | Performance XL               |        | 953524 |        |        |        |        |        | 203        | 42    |
| MAR-GYT3B-XL-25 | Performance XL               |        | 953526 |        |        |        |        |        | 203        | 42    |
| MAR-GYT4B-V6-23 | Performance 4-Blade          |        | 963523 |        |        |        |        | 993206 | 203        | 42    |
| MAR-GYT4B-V6-25 | Performance 4-Blade          |        | 963525 |        |        |        |        |        | 203        | 42    |
| MAR-GYT4B-V6-26 | Performance 4-Blade          |        | 963527 |        |        |        |        |        | 203        | 42    |
| MAR-VMAX3-04-18 |                              | 101034 | 933419 |        | 992114 | 993144 |        |        | See Note 1 | 41    |
| MAR-VMAX3-04-20 |                              | 101135 | 933421 |        | 992115 | 993145 |        |        | See Note 1 | 41    |
| MAR-VMAX3-04-22 |                              |        |        |        | 992116 | 993146 |        |        | See Note 1 | 41    |
| MAR-VMAX3-06-16 |                              | 101025 | 933517 |        | 992002 | 993042 | 993022 | 203    | 42,52      |       |
| MAR-VMAX3-06-18 |                              | 101027 | 933519 |        | 992003 | 993043 | 993023 | 993203 | 203        | 42,52 |
| MAR-VMAX3-06-20 |                              | 101028 | 933521 |        | 992004 | 993044 | 993024 | 993204 | 203        | 42,52 |
| MAR-VMAX3-06-22 |                              | 101029 | 933523 | 963523 | 992005 | 993045 | 993025 | 993205 | 203        | 42,52 |
| MAR-VMAX3-06-24 |                              |        | 933525 | 963525 | 992006 | 993046 | 993026 | 993206 | 203        | 42,52 |
| MAR-VMAX3-06-26 |                              |        | 963527 |        |        |        |        |        | 203        | 42,52 |
| MAR-VMAX3-C6-18 |                              |        | 937519 |        |        | 993053 | 93033  | 993213 | 203        | 42,52 |
| MAR-VMAX3-C6-20 |                              |        | 937521 |        |        | 993054 | 993034 | 993214 | 203        | 42,52 |
| MAR-VMAX3-C6-22 |                              |        | 937523 |        |        | 993056 | 993036 | 993216 | 203        | 42,52 |

| YAMAHA® |  |     |
|---------|--|-----|
| Note 1  | T50, 1996-Present; 15 Tooth Spline                     | 208 |
|         | 60-100 HP (Including 4-Stroke), 1984-Present; 15 Tooth | 208 |
|         | 80-140 HP, 1978-1983; 15 Tooth Spline                  | 202 |
|         | 115-130 HP, 1984-Present; 15 Tooth Spline              | 203 |

| HONDA® OUTBOARDS |   |     |
|------------------|---|-----|
| Note 3           | 75-90 HP, Thru 1988; 15 Tooth Spline      | 202 |
|                  | 75-90 HP, 1999-Present; 15 Tooth Spline   | 207 |
|                  | 115-130 HP, 1998-Present; 15 Tooth Spline | 207 |
| FORCE®           |   |     |
|                  | 75-150 HP, 1995-Present; 15 Tooth Spline  | 202 |
| YAMAHA®          |   |     |
|                  | 80-140 HP, 1978-1983; 15 Tooth Spline     | 202 |

| EVINRUDE®/JOHNSON® OUTBOARDS |   |     |
|------------------------------|---|-----|
| Note 5                       | 60 HP & 70 HP 4-Stroke, 1998-Present; 13 Tooth Spline | 210 |
|                              | All Other V4 Engine Applications; 13 Tooth Spline     | 206 |
| OMC®/COBRA® STERNDRIVES      |   |     |
|                              | Model 400/Cobra Sterndrives; 13 Tooth Spline          | 206 |

| EVINRUDE®/JOHNSON® OUTBOARDS |  |     |
|------------------------------|--|-----|
| Note 2                       | 90-140 HP Large Gearcase, 1976-1990; 15 Tooth Spline           | 201 |
|                              | 90-140 HP Large Gearcase, 1991-Present; 15 Tooth Spline        | 200 |
|                              | 150-300 HP, 1976-1990; 15 Tooth Spline                         | 201 |
|                              | 150-300 HP, 1991-Present; 15 Tooth Spline                      | 200 |
|                              | 200-300 HP G2 Applications ONLY, 2014-Present; 15 Tooth Spline | 228 |
| OMC®/COBRA® STERNDRIVES      |  |     |
|                              | Model 800/Cobra/King Cobra, 1978-1990; 15 Tooth Spline         | 201 |
|                              | Model 800/Cobra/King Cobra, 1991-1994; 15 Tooth Spline         | 200 |

| SUZUKI®  |  |     |
|----------|--|-----|
| Note 4   | DF90/DF115, 2001-Present; 15 Tooth Spline              | 225 |
|          | DF140, 2001-Present; 15 Tooth Spline                   | 226 |
|          | DF70A/DF80A/DF90A, 2009-Present; 15 Tooth Spline       | 227 |
| JOHNSON® |  |     |
|          | 90/115 HP (4-Stroke), 2003-Present; 15 Tooth Spline    | 225 |
|          | 140 HP (4-Stroke), 2003-Present; 15 Tooth Spline       | 226 |
| YAMAHA®  |  |     |
|          | 50-100 HP (Including 4-Stroke), 1984-Present; 15 Tooth | 208 |
|          | 115-130 HP, 1984-Present; 15 Tooth Spline              | 203 |

| Engine Year & Configuration   | XHS® Series |
|---|-------------|
| <b>Evinrude/Johnson</b>   |             |
| <b>15 HP (E-Tec)</b> 2011 & Newer; <b>20 HP</b> 1984-1997; <b>25 &amp; 30 HP</b> 1984 & Newer; <b>25 &amp; 30 HP (E-Tec)</b> 2009 & Newer; <b>35 HP</b> 1976 & Newer; 14 Tooth..... <b>118</b> ...E |             |
| <b>25 &amp; 30 HP (4-Stroke)</b> 2004-2007; 10 Tooth Spline..... <b>121</b> ...E  |             |
| <b>40 &amp; 50 HP (4-Stroke)</b> 1999-2005; 13 Tooth Spline..... <b>115</b> ...D  |             |
| <b>40-75 HP Small Gearcase</b> (3-3/8”) 1975-2005; 13 Tooth Spline..... <b>111</b> ...C   |             |
| <b>40-75 HP Large Gearcase</b> (4-1/4”) 1968 & Newer; 13 Tooth Spline..... <b>206</b> ...B  |             |
| <b>60 &amp; 70 HP (4-Stroke)</b> 1998 & Newer; 13 Tooth Spline ..... <b>210</b> ...B  |             |
| <b>85-140 HP</b> 1969 & Newer; 13 Tooth Spline ..... <b>206</b> ...B  |             |
| <b>90 &amp; 115 HP (4-Stroke)</b> 2002-2005; 15 Tooth Spline ..... <b>225</b> ...B  |             |
| <b>140 HP (4-Stroke)</b> 2002-2005; 15 Tooth Spline ..... <b>226</b> ...B   |             |
| <b>90-300 HP, Lg. Gearcase</b> 1976-1990; 15 Tooth Spline..... <b>201</b> ...A  |             |
| <b>90-300 HP, Lg. Gearcase</b> 1991 & Newer; 15 Tooth Spline ..... <b>200</b> ...A  |             |
| <b>200 &amp; 225 HP (4-Stroke)</b> 2004-2005; 15 Tooth Spline..... <b>204</b> ...A  |             |
| <b>150-300 HP E-TEC G2 Gearcase</b> 2014 & Newer; 15 Tooth Spline..... <b>228</b> ...A  |             |

| Force   |
|---|
| <b>25 HP</b> 1995-1998; 10 Tooth Spline ..... <b>120</b> ...E   |
| <b>40 &amp; 50 HP</b> 1995-1998; <b>70 HP</b> 1991-1995; <b>75 HP</b> 1996-1998; 13 Tooth <b>114</b> ...D |
| <b>75-150 HP</b> 1995-1999; <b>85-150 HP (Dual Exhaust)</b> 1988-1994; 15 Tooth. <b>202</b> ...B          |

| Honda  |
|--|
| <b>BF 25</b> 1994 & Newer; <b>BF 30</b> 1995 & Newer; 10 Tooth Spline ..... <b>119</b> ...E    |
| <b>BF 35 &amp; 45</b> 1991-1994; <b>BF 40/50/50A</b> 1995 & Newer;                             |
| <b>BF 60</b> ; 2010 & Newer; 13 Tooth Spline ..... <b>113</b> ...D                             |
| <b>BF 75 &amp; BF 90</b> 1995-1998; 15 Tooth Spline ..... <b>202</b> ...B                      |
| <b>BFP 60</b> 2010 & Newer; <b>BF 75 &amp; BF 90</b> 1999 & Newer; <b>BF 100</b> 2016 & Newer; |
| <b>BF 115</b> 1998-2010; <b>BF 130</b> 1998-2004; 15 Tooth Spline..... <b>207</b> ...B         |
| <b>BF 135-250 HP</b> 2002 & Newer; <b>BF 115D</b> 2011 & Newer; 15 Tooth ..... <b>207</b> ...A |

| Mercury/Mariner/Mercruiser   |
|--|
| <b>9.9, 15 HP (4-Stroke/Bigfoot/Sail)</b> 1999-2005; <b>18 HP (Mercury)</b> 1980-1985;           |
| <b>20 &amp; 25 HP (Not 4-Stroke)</b> 1980-2005; 10 Tooth Spline..... <b>120</b> ...E             |
| <b>25 &amp; 30 HP (4-Stroke - Not Bigfoot)</b> 2006 & Newer; 10 Tooth Spline ... <b>122</b> ...E |
| <b>25 HP Bigfoot</b> 1999-2005; <b>30 HP (Sea Pro/Marathon)</b> 1994 & Newer;                    |
| <b>30 HP (2- &amp; 4-Stroke)</b> 1994-2005; <b>35 HP</b> 1984-1989; <b>40-50 HP</b> 1974-1976;   |
| <b>40/50/70 HP</b> 1977-1984; <b>45 HP</b> 1986-1989;  |
| <b>40 &amp; 50 HP (2- &amp; 4-Stroke, Not Bigfoot)</b> 1977 & Newer;                             |
| <b>48 HP (Mariner)</b> All Years; <b>55 HP (Mercury/Sea Pro/Marathon)</b> 1995 & Newer;          |
| <b>60 HP (Not Bigfoot)</b> 1978 & Newer; <b>60 HP (Mariner)</b> 1976; <b>65 HP</b> 1972-1976;    |
| <b>70 HP</b> Thru 1983; <b>80 HP (Mariner)</b> 1977; 13 Tooth Spline ..... <b>114</b> ...D       |
| <b>40-140 HP (Except 135 HP) V4 Gearcase</b> 1961 & Newer; 15 Tooth ..... <b>202</b> ...B        |
| <b>135-300 HP</b> 1978 & Newer; 15 Tooth Spline ..... <b>202</b> ...A                            |
| <b>Mercruiser Alpha One &amp; Bravo One</b> (< 400 HP); 15 Tooth Spline..... <b>202</b> ...A     |

| Engine Year & Configuration  | XHS® Series |
|--|-------------|
| <b>Nissan/Tohatsu</b>  |             |
| <b>25 &amp; 30 HP</b> 1985-2001; <b>25 &amp; 30 HP (4-Stroke)</b> 2002 & Newer..... <b>122</b> ...E  |             |
| <b>35 HP (35B Only)</b> Thru 1984; <b>40 HP</b> 1984 & Newer;  |             |
| <b>50 HP (All Except 50C)</b> 1992 & Newer; 13 Tooth Spline ..... <b>116</b> ...D                    |             |
| <b>50 HP (50C Only)</b> 1987-1991; <b>55 HP</b> 1981-1988;   |             |
| <b>60A</b> 1986-1999; <b>70A &amp; 70B</b> 1981-1995; 13 Tooth Spline..... <b>112</b> ...C           |             |
| <b>60-140 HP, 4-1/4” Gearcase</b> 1987 & Newer; 15 Tooth Spline..... <b>209</b> ...B                 |             |
| <b>OMC/Cobra Sterndrives</b>   |             |
| <b>Model 400 Cobra</b> 1978-1991; 13 Tooth Spline..... <b>206</b> ...B                               |             |
| <b>Model 800/Cobra/King Cobra</b> 1978-1990; 15 Tooth Spline ..... <b>201</b> ...A                   |             |
| <b>Model 800/Cobra/King Cobra</b> 1991-1994; 15 Tooth Spline ..... <b>200</b> ...A                   |             |
| <b>Cobra SX</b> 1994 & Newer; 19 Tooth Spline ..... <b>205</b> ...A                                  |             |
| <b>Suzuki</b>  |             |
| <b>DT 20 &amp; DT 25</b> 1985-1988; <b>DT 25C</b> 1989-2000; <b>DF 25A</b> 2014 & Newer;             |             |
| <b>DT 30</b> 1983-1997; <b>DT 30C</b> 1987-1997; <b>DF 30A</b> 2014 & Newer;                         |             |
| <b>DF 25 &amp; DF 30 (4-Stroke)</b> 2000-2007; 10 Tooth ..... <b>121</b> ...E                        |             |
| <b>DT 35C</b> 1987-1989; <b>DT 40</b> 1983-1998; <b>DF 40 &amp; DF 50 (4-Stroke)</b> 1999-2010;      |             |
| <b>DF 40A &amp; 50A</b> 2011 & Newer; <b>DT 50 &amp; 50M</b> 1983-1984; <b>DT 55</b> 1985-1997;      |             |
| <b>DT 60</b> 1983-1984; <b>DF 60A</b> 2010 & Newer; <b>DT 65</b> 1985-1997; 13 Tooth <b>115</b> ...D |             |
| <b>DF 60 (4-Stroke)</b> 1998-2009; <b>DF 70 (4-Stroke)</b> 1998-2008;                                |             |
| <b>DT 75/85/100/115/140</b> 1979-2001; 13 Tooth Spline ..... <b>210</b> ...B                         |             |
| <b>DF 50AV/60AV</b> 2015 & Newer; <b>DF 90</b> 2001-2008;  |             |
| <b>DF 100</b> 2009 & Newer; <b>DF 115</b> 2001-2012; 15 Tooth Spline ..... <b>225</b> ...B           |             |
| <b>DF 115A &amp; 140A</b> 2013 & Newer; <b>DF 140</b> 2002-2012; 15 Tooth Spline ... <b>226</b> ...B |             |
| <b>DF 70A/80A/90A</b> 2009 & Newer; 15 Tooth Spline ..... <b>227</b> ...B                            |             |
| <b>150-300 HP (Including 4-Stroke)</b> 1986 & Newer; 15 Tooth Spline ..... <b>204</b> ...A           |             |

| Yamaha   |
|--|
| <b>20 HP</b> 1996-1997; <b>25 HP</b> 1980 & Newer; <b>F25 (4-Stroke)</b> 1998-2006               |
| <b>F25 (4-Stroke)</b> 2010 & Newer; <b>30 HP</b> 1983-2002; 10 Tooth Spline..... <b>123</b> ...E |
| <b>T25</b> 2010 & Newer; <b>F30 (4-Stroke)</b> 2001-2005;  |
| <b>40 HP &amp; 50 HP (Not T50)</b> 1984 & Newer; <b>F40 (4-Stroke)</b> 1999 & Newer;             |
| <b>48 HP</b> 1995-2000; <b>F50 (4-Stroke)</b> 1995 & Newer; <b>55 HP</b> 1976-1995;              |
| <b>60 HP</b> 1976-1991; <b>F60 (4-Stroke)</b> 1999 & Newer ..... <b>117</b> ...D                 |
| <b>50-100 HP (Including 4-Stroke)</b> 1984 & Newer; 15 Tooth Spline ..... <b>208</b> ...B        |
| <b>115 &amp; 130 HP</b> 1984 & Newer; <b>F115 (4-Stroke)</b> 2000 & Newer..... <b>203</b> ...B   |
| <b>80-140 HP</b> 1977-1983; 15 Tooth Spline..... <b>202</b> ...B                                 |
| <b>150-175 HP</b> 1978-1983; 15 Tooth Spline..... <b>202</b> ...A                                |
| <b>150-300 HP (Including 4-Stroke)</b> 1984 & Newer; <b>300 HP</b> 2004-07 ..... <b>203</b> ...A |
| <b>Sterndrives</b> 1989-1993; 15 Tooth Spline ..... <b>203</b> ...A                              |

| Volvo Penta   |
|---|
| <b>SX Sterndrives</b> 1994 & Newer; 19 Tooth Spline ..... <b>205</b> ...A |

| VORTEX® XHS® SERIES ALUMINUM PROPELLERS |       |        |               |       |        |               |       |        |                      |       |        |                          |       |        |                  |       |        |
|---|-------|--------|---------------|-------|--------|---------------|-------|--------|----------------------|-------|--------|--------------------------|-------|--------|------------------|-------|--------|
| PROP SERIES A                           |       |        | PROP SERIES B |       |        | PROP SERIES C |       |        | PROP SERIES D        |       |        |                          |       |        | PROP SERIES E    |       |        |
| 3 & 4-Blade                             |       |        | 3 & 4-Blade   |       |        | 3 & 4-Blade   |       |        | Standard 3 & 4-Blade |       |        | Lg. Diameter 3 & 4-Blade |       |        | Standard 3-Blade |       |        |
| DIA x PITCH                             | BLD # | P/N    | DIA x PITCH   | BLD # | P/N    | DIA x PITCH   | BLD # | P/N    | DIA x PITCH          | BLD # | P/N    | DIA x PITCH              | BLD # | P/N    | DIA x PITCH      | BLD # | P/N    |
| 16 x 13                                 | 3     | 992001 | 14 x 10       | 3     | 992109 | 11-1/2 x 8    | 4     | 992401 | 10-5/8 x 12          | 4     | 941212 | 11-1/2 x 8               | 4     | 992401 | 10-1/2 x 9       | 3     | 992501 |
| 15-1/4 x 15                             | 3     | 992002 | 14 x 11       | 3     | 992111 | 11-1/2 x 9    | 4     | 992402 | 10-5/8 x 13          | 4     | 941213 | 11-1/2 x 9               | 4     | 992402 | 10-1/2 x 10      | 3     | 992502 |
| 16 x 16                                 | 3     | 931516 | 13-3/4 x 13   | 3     | 992112 | 11-1/2 x 10   | 4     | 992403 | 10-1/8 x 14          | 4     | 941214 | 11-1/2 x 10              | 4     | 992403 | 10-1/2 x 11      | 3     | 992503 |
| 15 x 17                                 | 3     | 992003 | 13-1/2 x 15   | 3     | 992113 | 11-3/4 x 13   | 3     | 992301 | 10-1/8 x 15          | 4     | 941215 | 12-1/4 x 9               | 3     | 992601 | 10-1/8 x 12      | 3     | 992504 |
| 14-1/2 x 19                             | 3     | 992004 | 13-1/4 x 17   | 3     | 992114 | 11-3/4 x 15   | 3     | 992302 | 10-3/8 x 11          | 3     | 992404 | 11-3/4 x 10              | 3     | 992602 | 10-1/8 x 13      | 3     | 992505 |
| 14-1/4 x 21                             | 3     | 992005 | 13 x 19       | 3     | 992115 | 11-3/4 x 17   | 3     | 992303 | 10-3/8 x 12          | 3     | 992405 | 11-5/8 x 11              | 3     | 992603 | 10-1/8 x 14      | 3     | 992506 |
| 14 x 23                                 | 3     | 992006 | 13 x 21       | 3     | 992116 | 12-1/2 x 13   | 3     | 992311 | 10-3/8 x 13          | 3     | 992406 | 11-3/8 x 12              | 3     | 992604 |                  |       |        |
| 15 x 16                                 | 4     | 992202 | 13-7/8 x 11   | 4     | 941411 | 12-1/4 x 15   | 3     | 992312 | 10-3/8 x 14          | 3     | 992407 | 11-1/8 x 13              | 3     | 992605 |                  |       |        |
| 14-1/2 x 18                             | 4     | 992203 | 13-7/8 x 13   | 4     | 941413 |               |       |        | 10 x 15              | 3     | 992408 | 11-1/4 x 14              | 3     | 992606 |                  |       |        |
| 14 x 20                                 | 4     | 992204 | 13-3/8 x 15   | 4     | 941415 |               |       |        | 10 x 16              | 3     | 992409 |                          |       |        |                  |       |        |
|   |       |        | 13 x 17       | 4     | 941417 |               |       |        |                      |       |        |                          |       |        |                  |       |        |
|   |       |        | 12-1/2 x 19   | 4     | 941419 |               |       |        |                      |       |        |                          |       |        |                  |       |        |

| BALLISTIC® XHS® SERIES STAINLESS STEEL PROPELLERS |        |        |              |       |        |                                  |              |        |                  |                  |                  |        |             |        |  |  |  |
|---|--------|--------|--------------|-------|--------|----------------------------------|--------------|--------|------------------|------------------|------------------|--------|-------------|--------|--|--|--|
| PROP SERIES A<br>V8/V6 APPLICATIONS               |        |        |              |       |        | PROP SERIES B<br>V4 APPLICATIONS |              |        | PROP SERIES C    | PROP SERIES D    | PROP SERIES E    |        |             |        |  |  |  |
| Standard 3-Blade                                  |        |        | Ballistic XL |       |        | Standard 3-Blade & XL            |              |        | Standard 3-Blade | Standard 3-Blade | Standard 3-Blade |        |             |        |  |  |  |
| DIA x PITCH                                       | RH P/N | LH P/N | DIA x PITCH  | BLD # | RH P/N | DIA x PITCH                      | BLD #        | RH P/N | DIA x PITCH      | RH P/N           | DIA x PITCH      | RH P/N | DIA x PITCH | RH P/N |  |  |  |
| 14-7/8 x 15                                       | 933515 |        | 14-3/4 x 22  | 3     | 953522 | 13-5/8 x 15                      | Std. 3-Blade | 933415 | 12-3/8 x 15      | 933315           | 10-1/8 x 13      | 933213 | 10-1/8 x 13 | 933013 |  |  |  |
| 14-3/4 x 17                                       | 933517 | 937517 | 14-3/4 x 24  | 3     | 953524 | 13-1/2 x 17                      | Std. 3-Blade | 933417 | 12 x 17          | 933317           | 10-1/8 x 15      | 933215 | 10-1/8 x 15 | 933015 |  |  |  |
| 14-1/2 x 19                                       | 933519 | 937519 | 14-3/4 x 26  | 3     | 953526 | 13-3/8 x 19                      | Std. 3-Blade | 933419 |                  |                  |                  |        |             |        |  |  |  |
| 14-3/8 x 21                                       | 933521 | 937521 |              |       |        | 13-1/8 x 21                      | Std. 3-Blade | 933421 |                  |                  |                  |        |             |        |  |  |  |
| 14-1/4 x 23                                       | 933523 | 937523 | 14-1/8 x 23  | 4     | 963523 |                                  |              |        |                  |                  |                  |        |             |        |  |  |  |
| 14-1/4 x 25                                       | 933525 |        | 14-1/8 x 25  | 4     | 963525 | 13-1/2 x 22                      | 3-Blade XL   | 953422 |                  |                  |                  |        |             |        |  |  |  |
|   |        |        | 14-1/8 x 27  | 4     | 963527 | 13-1/2 x 24                      | 3-Blade XL   | 953424 |                  |                  |                  |        |             |        |  |  |  |

\* For Apollo XHS Series Stainless Steel propeller offering, please refer to 2019 XHS Application Chart, or applicable engine category within this catalog.



## LIMITED WARRANTY

Michigan Wheel warrants to the original consumer purchaser and original motor fitted, that for a period of one year from the date of purchase, the body of the Michigan Match®, Vortex®, Apollo® or Ballistic® propeller will be free of any defect in material or workmanship that results in blade or hub fracture or failure under normal pleasure boat usage. Michigan Wheel also warrants to the original consumer purchaser, under the same parameters of use described above, that the propeller bushing, including XHS®/XHS II® hub kit components, will be free from any defect in material or workmanship for a period of one year from the date of purchase. Proof of purchase required for all warranty claims.

Some surface discoloration of propellers and hardware is unavoidable, and will not be covered by this warranty. This warranty also does not cover normal wear, accidental damage, modification, improper installation, improper maintenance, or other circumstances that are not the direct result of a defect in the material or workmanship of the propeller.

The sole obligation of Michigan Wheel under this warranty is to repair or replace the propeller, in the sole discretion of Michigan Wheel, and at its expense. In order to make a replacement claim, please contact the Michigan Wheel Customer Service Department, at (616) 452-6941, for a “Return Materials Authorization” number (RMA#), and shipping instructions. The RMA# is to be indicated along with our given address on the label, and the shipping carton should include your return shipping address, your phone number, and a copy of your original purchase receipt. The warranty will not cover any expense of propeller removal, shipping, or reinstallation of the propeller.

The above warranty is Michigan Wheel’s sole warranty for the Michigan Match®, Vortex®, Apollo® or Ballistic® propellers as well as XHS®/XHS II® hub kits. Michigan Wheel expressly disclaims all other warranties, expressed or implied, including, without limitation, the warranties of merchantability and fitness for a particular purpose and excludes all liability for incidental or consequential damages, loss of use of the propeller, costs, and expenses.

Any actions arising out of this warranty and the sale of this product shall be governed by Michigan law and may only be brought, heard and decided in Kent County Circuit Court, in the State of Michigan, U.S.A., or in the United States District Court for the Western District of Michigan.

Michigan Wheel  
1501 Buchanan Avenue S.W.  
Grand Rapids, MI 49507  
Phone: (616) 452-6941

| Need Your Propeller Repaired?   |
|---|
| Congratulations, you have chosen a top quality propeller. Should it become damaged during use, you want a qualified trained technician to repair it. Contact the <b>National Marine Propeller Association (NMPA)</b> at 954-880-3588 (F: 954-239-2600), or visit them on the web (www.nmpa.net) for a certified propeller repair shop near you. |
| Warranty claims are to be addressed directly to <b>Michigan Wheel</b> per instructions on this warranty statement and not to the <b>NMPA</b> .  |

**GOMBI**FREIZEIT

[gombi-freizeit.hu](http://gombi-freizeit.hu)